

第七部分 电气系统目录
PART VII Electrical system contents

- Ⓐ CPCD30/35-XW33F Ⓑ CPCD30/35-XW33B Ⓒ CPCD30/35-XW33M Ⓓ CPYD30/35-XW22F Ⓔ CPYD30/35-XW52F
 Ⓔ CPYD30/35-XW22B Ⓕ CPYD30/35-XW52B Ⓖ CPYD30/35-XW22M Ⓕ CPYD30/35-XW52M Ⓖ CPCD30/35-XW27F
 Ⓕ CPCD30-XW13F Ⓖ CPCD30-XW10F Ⓖ CPQD30/35-XW22F Ⓖ CPQD30/35-XW22B Ⓖ CPQD30/35-XW22M

序号 Item	名称 Description	适用车型 Serial No.	页码 Page
图 1 Fig. 1	电气系统 Electrical system	Ⓐ Ⓑ Ⓒ	7-1
图 2 Fig. 2	电气系统 Electrical system	Ⓓ Ⓔ Ⓕ Ⓖ Ⓕ Ⓖ	7-5
图 3 Fig. 3	电气系统 Electrical system	Ⓓ Ⓔ Ⓕ 双燃料叉车选配 For dual fuel (gasoline/LPG) engine	7-9
图 4 Fig.4	电气系统 Electrical system	Ⓖ Ⓖ Ⓖ	7-13
图 5 Fig.5	电气系统 Electrical system	Ⓖ	7-17
图 6 Fig. 6	电气系统 Electrical system	Ⓖ Ⓖ	7-20
图 7 Fig. 7	前灯总成 front lamps assy	全部车型 All models of truck	7-24
图 8 Fig. 8	后灯总成 rear lamps assy	全部车型 All models of truck	7-25
图 8-1 Fig. 8-1	后组合灯 Rear-combination lamps	全部车型 All models of truck	7-26
图 9 Fig. 9	喇叭总成 Horn assy	全部车型 All models of truck	7-27
图 10 Fig. 10	控制盒总成 Control box assy	全部车型 (Ⓖ 除外) All models of truck (Except Ⓖ)	7-28

序号 Item	名称 Description	适用车型 Serial No.	页码 Page
图 11 Fig.11	控制盒总成 Control box assy	Ⓒ	7-29
图 12 Fig. 12	组合开关 Combination Switch assy	全部车型 All models of truck	7-30
图 13 Fig. 13	组合仪表总成 Instrument assy	全部车型 All models of truck	7-31
图 14 Fig. 14	电气系统 (CE) Electrical system (CE)	Ⓓ Ⓔ Ⓕ	7-32
图 15 Fig. 16	电气系统 (CE) Electrical system (CE)	Ⓐ Ⓑ Ⓒ	7-36
图 16 Fig.16	电气系统 (CE) Electrical system (CE)	Ⓒ	7-41
图 17 Fig.17	电气系统 (CE) Electrical system (CE)	①	7-45
图 18 Fig.18	电气系统 (CE) Electrical system (CE)	Ⓙ Ⓚ Ⓛ	7-49

图 1 电气系统
Fig.1 Electrical system

Ⓐ CPCD30/35-XW33F Ⓑ CPCD30/35-XW33B Ⓒ CPCD30/35-XW33M



图 1 电气系统
Fig.1 Electrical system

Ⓐ CPCD30/35-XW33F Ⓑ CPCD30/35-XW33B Ⓒ CPCD30/35-XW33M

序号 Item	物料码 Part NO.	名称 Description	数量 Qty	备注或适用车型 Remarks Or Serial NO.
1	XF250-760000-000	前灯总成 front lamps assy	1	见图 7 See Fig.7
2	XF250-770000-000	后灯总成 rear lamps assy	1	见图 8 See Fig.8
3	XF250-706000-000	控制盒 Control box	1	见图 10 See Fig.10 ≤2011-07
3	XF250-706000-001	控制盒 Control box	1	见图 10 See Fig.10 ≥2011-08
4	N163-700009-000	喇叭总成 Horn assy	1	见图 9 See Fig.9
5	R450-740200-000	预热起动开关 Pre-heat & start switch	1	
6	XF250-705000-000	组合开关 Combination Switch assy	1	见图 12 See Fig.12
7	XF250-740000-000	组合仪表总成 Instrument assy	1	见图 13 See Fig.13
8	6A60	二极管 Diode	2	
9	XF250-730000-000	前灯线束 Cable	1	≤2009-07
10	XF250-780000-000	后灯线束 Cable	1	
11		喇叭按钮 Horn button	(1)	方向盘 Supply by steering wheel
12	XF250-700200-000	油温报警器 Fuel temperature warning	1	Ⓐ
	WG-2K(M16*1.5)-G00		1	Ⓑ
	11AB-00680		(1)	Ⓒ 变速箱配套 Supply by transmission

图 1 电气系统
Fig.1 Electrical system

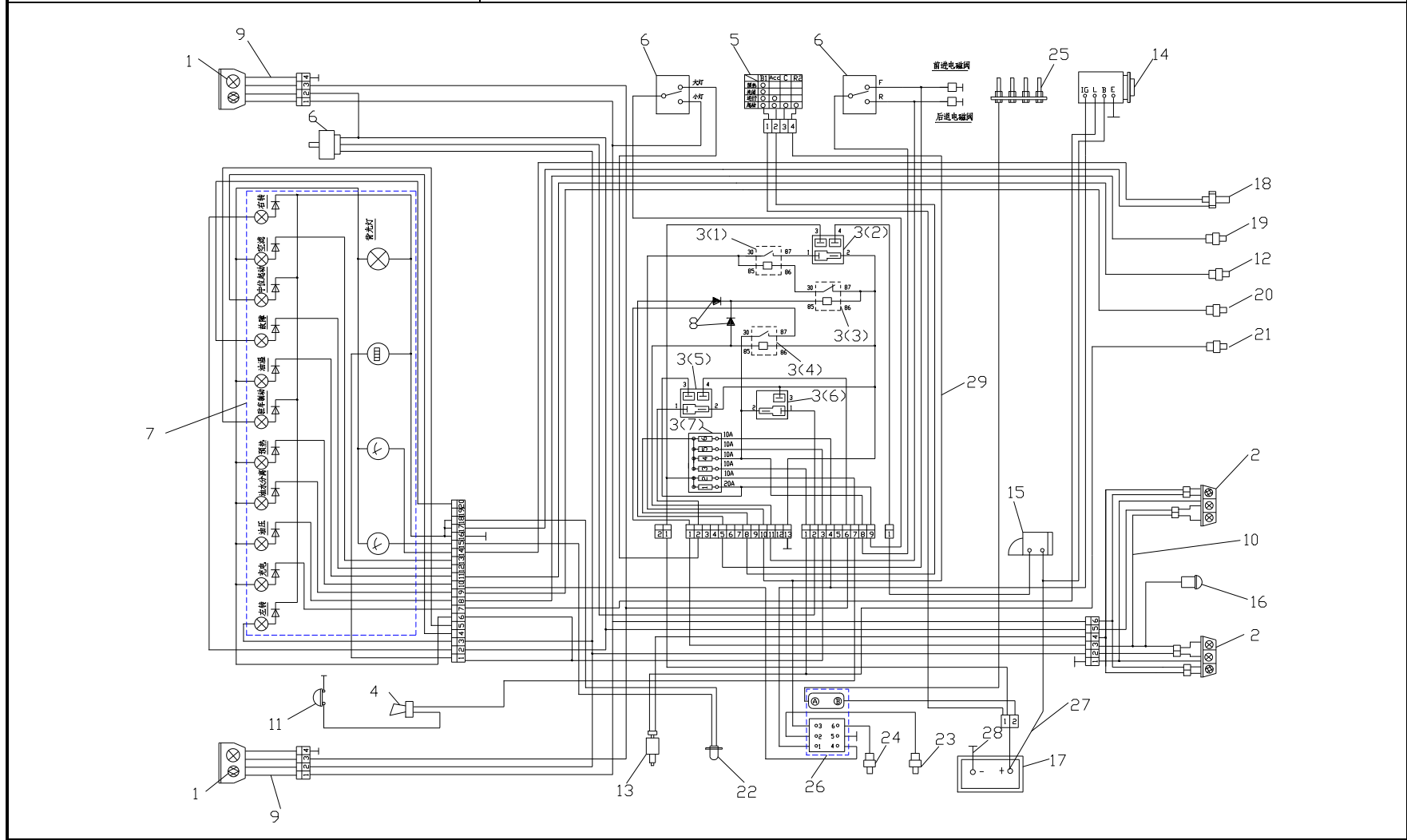
Ⓐ CPCD30/35-XW33F Ⓑ CPCD30/35-XW33B Ⓒ CPCD30/35-XW33M

序号 Item	物料码 Part NO.	名称 Description	数量 Qty	备注或适用车型 Remarks Or Serial NO.
13	N163-700600-000	制动灯开关 Brake switch	1	
14	129930-77212	发电机 12V/40A Alternator 12V/40A	(1)	发动机配套 Supply by engine
15	129900-77010	起动机 12V/2.3KW Starter 12V/2.3KW	(1)	发动机配套 Supply by engine
16	N163-700500-000	倒车报警器 Reverse warner	1	
17	R450-700001-000	免维护蓄电池 Battery, Maintenance-free	1	12V 90Ah
-	R960-700002-000	少维护蓄电池 Battery, Low-Maintenance	1	12V 90Ah
18	XF250-700100-000	水温传感器 Water temp .sending unit	1	
19	114250-39450	油压报警器 Fuel pressure warner	(1)	发动机配套 Supply by engine
20	129917-55800	油水分离报警开关 oil-water separation warning switch	(1)	发动机配套 Supply by engine
21	129612-52100	燃油切断开关 Fuel shut off solenoid	(1)	发动机配套 Supply by engine
22	XF250-700400-000	油量传感器 Fule level sending unit	1	
23		回油电磁阀 Return fuel Solenoid valve	(1)	发动机配套 Supply by engine
24	129107-44901	水温开关 Water temperature switch	(1)	发动机配套 Supply by engine
25	119717-77800	预热塞 Glow plug	(1)	发动机配套 Supply by engine
26	129930-77970	QGS 控制盒 12V QGS Controller 12V	(1)	发动机配套 Supply by engine



图 1 电气系统

Fig.1 Electrical system

Ⓐ CPCD30/35-XW33F Ⓑ CPCD30/35-XW33B Ⓒ CPCD30/35-XW33M

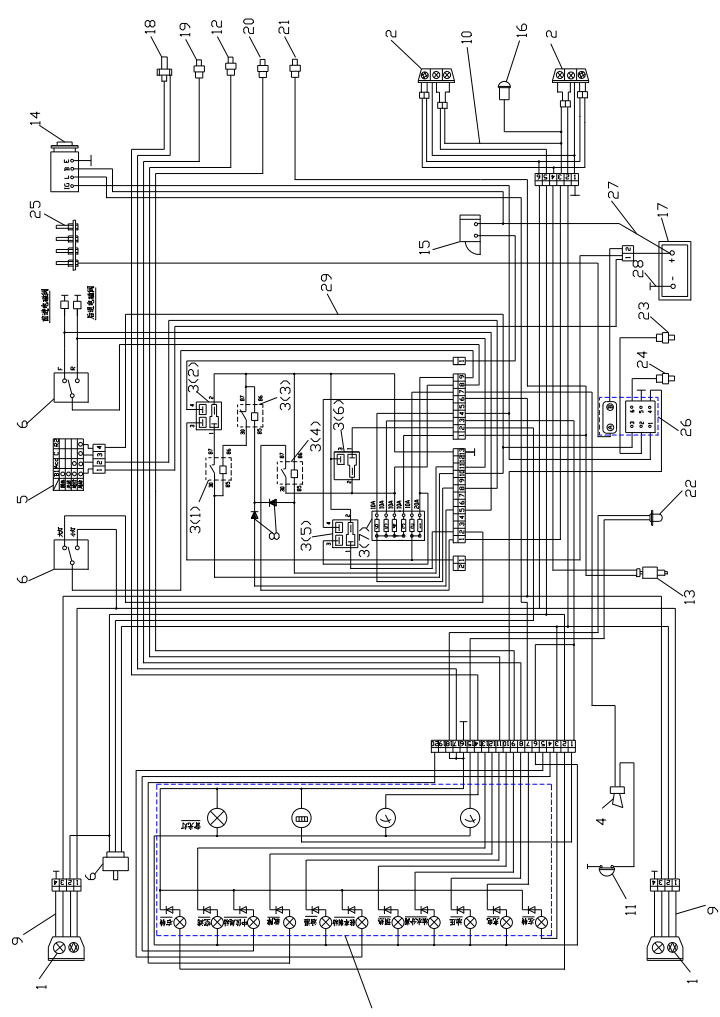
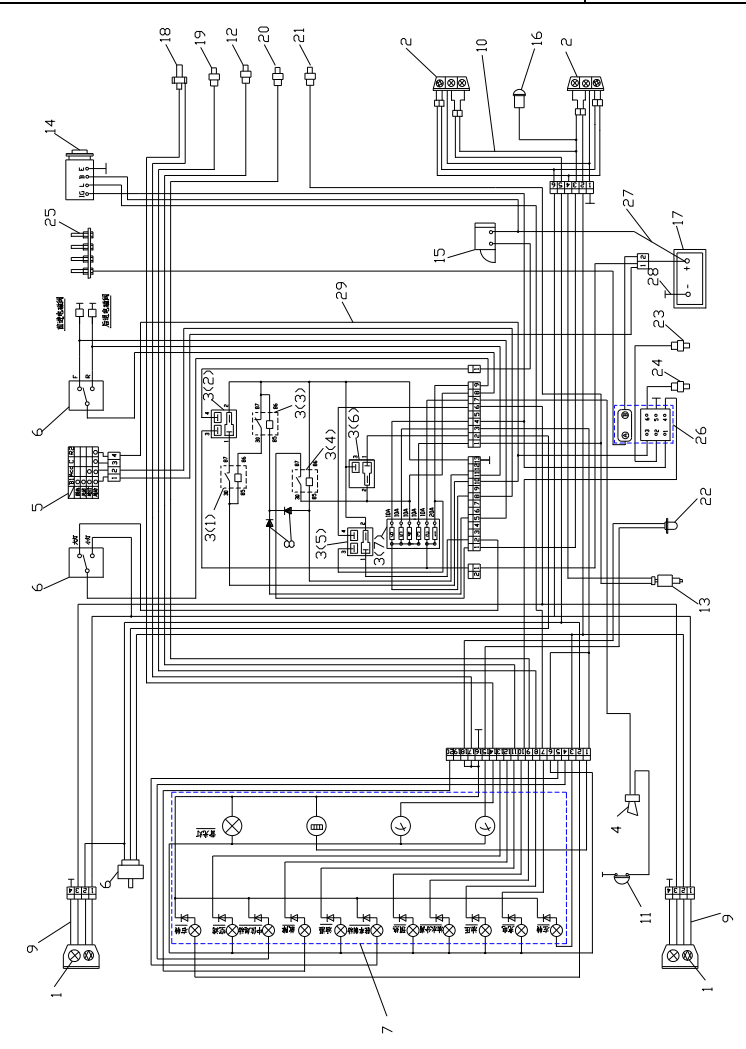

序号 Item	物料码 Part NO.	名称 Description	数量 Qty	备注或适用车型 Remarks Or Serial NO.
27	XF250-702000-000	蓄电池正级引线 Battery positive cable	1	
28	N163-700200-000	蓄电池负级引线 Battery negative cable	1	
29	XF250-710000-000	车身主线束 Main wire-harness	1	Ⓐ ≤2011-07
29	XF250-710000-001	车身主线束 Main wire-harness	1	Ⓐ ≥2011-08
29	XB250-710000-000	车身主线束 Main wire-harness	1	Ⓑ ≤2011-07
29	XB250-710000-001	车身主线束 Main wire-harness	1	Ⓑ ≥2011-08
29	XM250-710000-000	车身主线束 Main wire-harness	1	Ⓒ ≤2011-07
29	XM250-710000-001	车身主线束 Main wire-harness	1	Ⓒ ≥2011-08

图2 电气系统
Fig.2 Electrical system

- Ⓓ CPYD30/35-XW22F Ⓛ CPYD30/35-XW52F ⓔ CPYD30/35-XW22B ⓔ CPYD30/35-XW52B
 ⓕ CPYD30/35-XW22M ⓕ CPYD30/35-XW52M



图2 电气系统
Fig.2 Electrical system

Ⓓ CPYD30/35-XW22F Ⓓ1 CPYD30/35-XW52F Ⓔ CPYD30/35-XW22B Ⓔ1 CPYD30/35-XW52B
Ⓕ CPYD30/35-XW22M Ⓕ1 CPYD30/35-XW52M

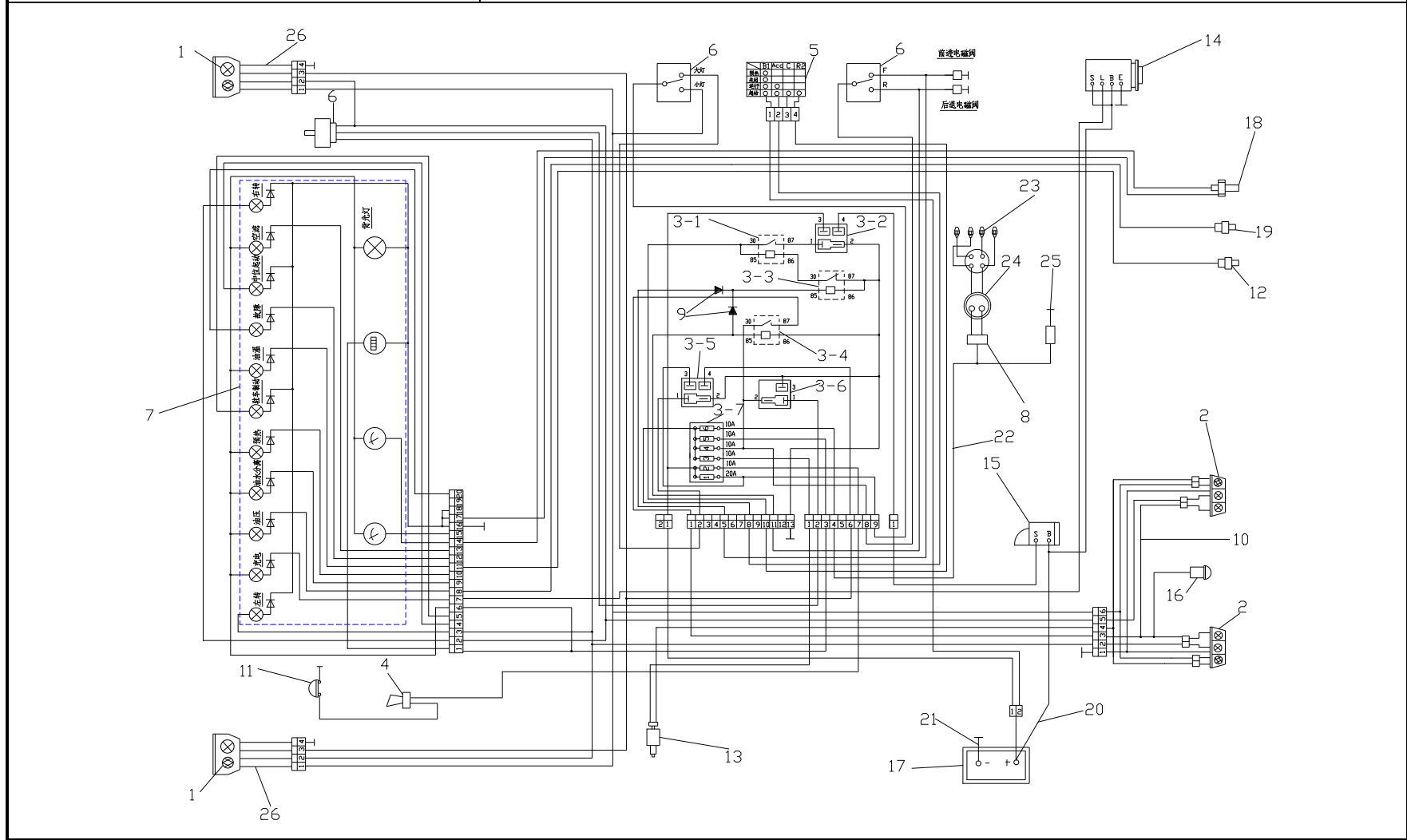
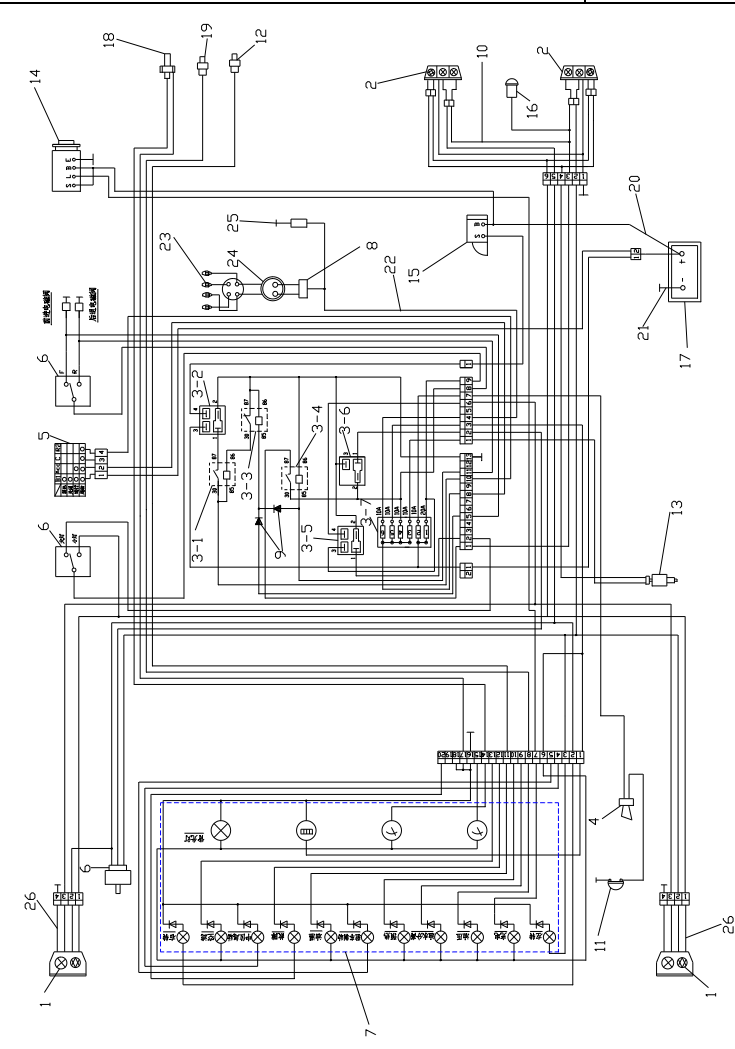

序号 Item	物料码 Part NO.	名称 Description	数量 Qty	备注或适用车型 Remarks Or Serial NO.
1	XF250-760100-000	前灯总成 front lamps assy	1	见图 7 See Fig.7
2	XF250-770000-000	后灯总成 rear lamps assy	1	见图 8 See Fig.8
3		控制盒 Control box	1	Ⓓ Ⓔ Ⓕ 见图 10 See Fig.10
3		控制盒 Control box	1	Ⓓ1 Ⓔ1 Ⓕ1 见图 10 See Fig.10
4	N163-700009-000	喇叭总成 Horn assy	1	见图 9 See Fig.9
5	R450-740200-000	预热起动开关 Pre-heat & start switch	(1)	
6	XF250-705000-000	组合开关 Combination Switch assy	1	见图 12 See Fig.12
7	XF250-740000-000	组合仪表总成 Instrument assy	1	见图 13 See Fig.13
8	T6T87779	点火线圈 ignition coil	(1)	发动机配套 Supply by engine
9	6A60	二极管 Diode	2	
10	XF250-780000-000	后灯线束 Cable	1	
11		喇叭按钮 Horn button	(1)	方向盘 Supply by steering wheel
12	XF250-700200-000	油温报警器 Fuel temperature warning	(1)	Ⓓ Ⓓ1 组合仪表配套 Combination meter
	WG-2K(M16*1.5)-G00		(1)	Ⓔ Ⓔ1 组合仪表配套 Combination meter
	11AB-00680		(1)	Ⓕ Ⓕ1 变速箱配套 Supply by transmission box

图2 电气系统
Fig.2 Electrical system

Ⓓ CPYD30/35-XW22F Ⓓ1 CPYD30/35-XW52F Ⓔ CPYD30/35-XW22B Ⓔ1 CPYD30/35-XW52B
Ⓕ CPYD30/35-XW22M Ⓕ1 CPYD30/35-XW52M

序号 Item	物料码 Part NO.	名称 Description	数量 Qty	备注或适用车型 Remarks Or Serial NO.
13	N163-700600-000	制动灯开关 Brake switch	1	
14	23100-50K10	发电机 12V/50A Alternator 12V/50A	(1)	发动机配套 Supply by engine
15	23300-K9160	起动机 12V/1.2KW Starter 12V/1.2KW	(1)	发动机配套 Supply by engine
16	N163-700500-000	倒车报警器 Reverse warner	1	
17	R9619-700001-000	免维护蓄电池 Battery, Maintenance-free	1	12V 60Ah
17	R840-700001-000	少维护蓄电池 Battery, Low-Maintenance	1	12V 60Ah
18	XF251-700100-000	水温传感器 Water temp.sending unit	(1)	组合仪表配套 Combination meter
19	25240-89911	油压报警器 Fuel pressure warner	(1)	发动机配套 Supply by engine
20	XF250-702000-000	蓄电池正级引线 Battery positive cable	1	
21	N163-700200-000	蓄电池负级引线 Battery negative cable	1	
22	XF251-710000-000	车身主线束 Main wire-harness	1	Ⓓ
22	XF2511-710000-001	车身主线束 Main wire-harness	1	Ⓓ1
22	XB251-710000-000	车身主线束 Main wire-harness	1	Ⓔ
22	XB257-710000-001	车身主线束 Main wire-harness	1	Ⓔ1
22	XM251-710000-000	车身主线束 Main wire-harness	1	Ⓕ

图3 电气系统
Fig.3 Electrical system

Ⓓ CPYD30/35-XW22F Ⓔ CPYD30/35-XW22B Ⓕ CPYD30/35-XW22M
双燃料叉车选配 For dual fuel (gasoline/LPG) engine



图3 电气系统
Fig.3 Electrical system

Ⓓ CPYD30/35-XW22F Ⓔ CPYD30/35-XW22B Ⓕ CPYD30/35-XW22M
双燃料叉车选配 For dual fuel (gasoline/LPG) engine

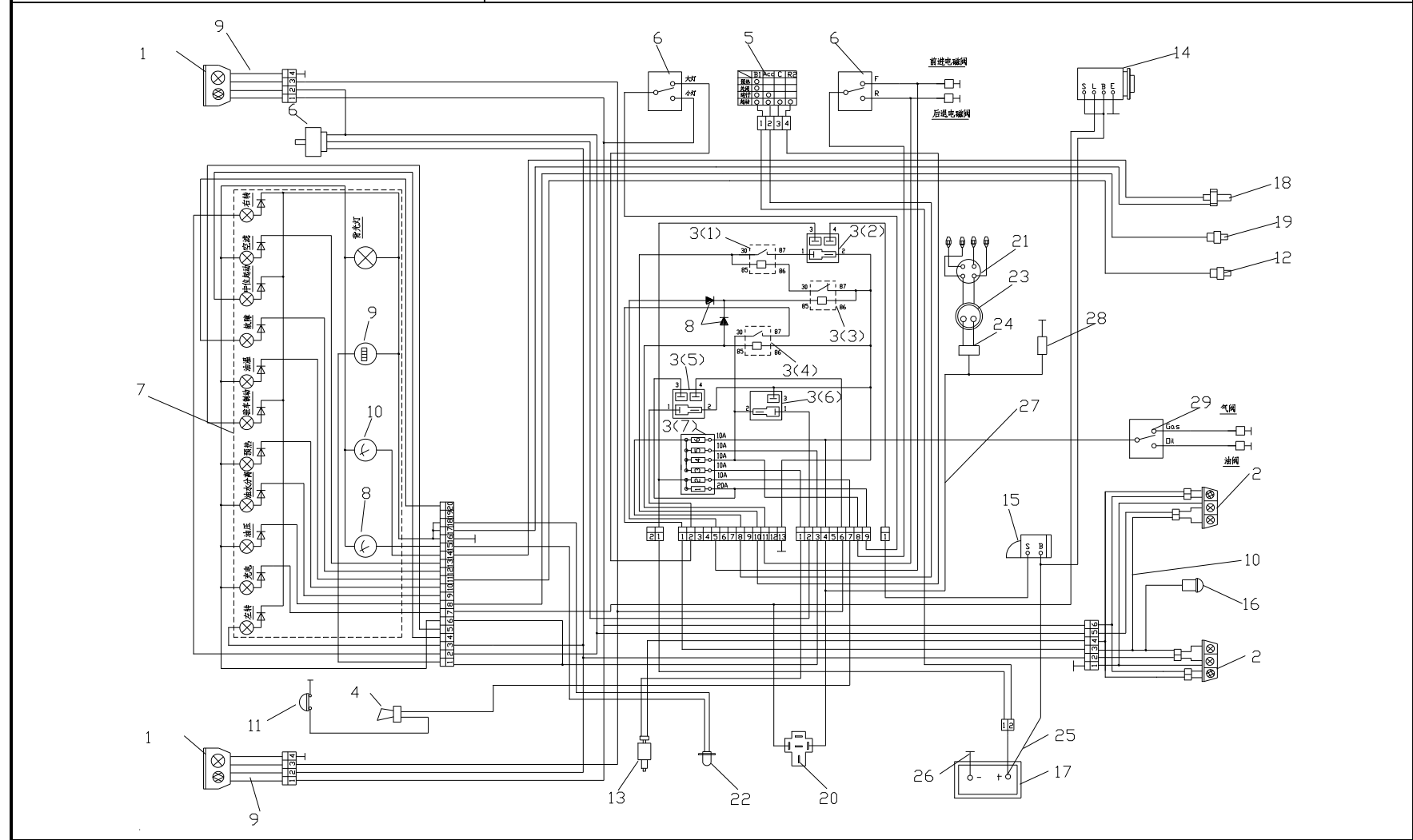
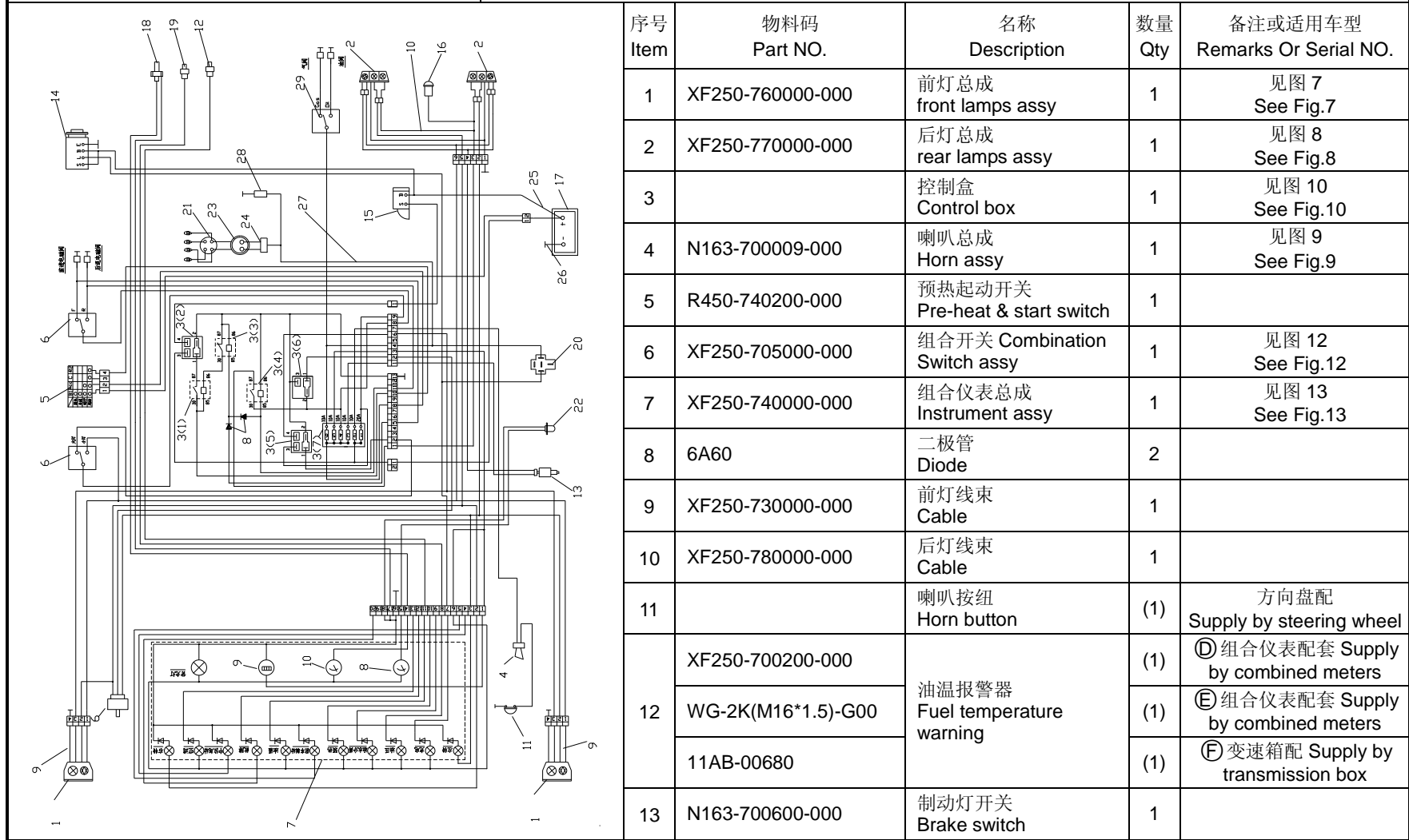

序号 Item	物料码 Part NO.	名称 Description	数量 Qty	备注或适用车型 Remarks Or Serial NO.
1	XF250-760000-000	前灯总成 front lamps assy	1	见图 7 See Fig.7
2	XF250-770000-000	后灯总成 rear lamps assy	1	见图 8 See Fig.8
3		控制盒 Control box	1	见图 10 See Fig.10
4	N163-700009-000	喇叭总成 Horn assy	1	见图 9 See Fig.9
5	R450-740200-000	预热启动开关 Pre-heat & start switch	1	
6	XF250-705000-000	组合开关 Combination Switch assy	1	见图 12 See Fig.12
7	XF250-740000-000	组合仪表总成 Instrument assy	1	见图 13 See Fig.13
8	6A60	二极管 Diode	2	
9	XF250-730000-000	前灯线束 Cable	1	
10	XF250-780000-000	后灯线束 Cable	1	
11		喇叭按钮 Horn button	(1)	方向盘配 Supply by steering wheel
12	XF250-700200-000	油温报警器 Fuel temperature warning	(1)	Ⓓ 组合仪表配套 Supply by combined meters
	WG-2K(M16*1.5)-G00		(1)	Ⓔ 组合仪表配套 Supply by combined meters
	11AB-00680		(1)	Ⓕ 变速箱配 Supply by transmission box
13	N163-700600-000	制动灯开关 Brake switch	1	

图3 电气系统
Fig.3 Electrical system

Ⓓ CPYD30/35-XW22F Ⓔ CPYD30/35-XW22B Ⓕ CPYD30/35-XW22M
双燃料叉车选配 For dual fuel (gasoline/LPG) engine

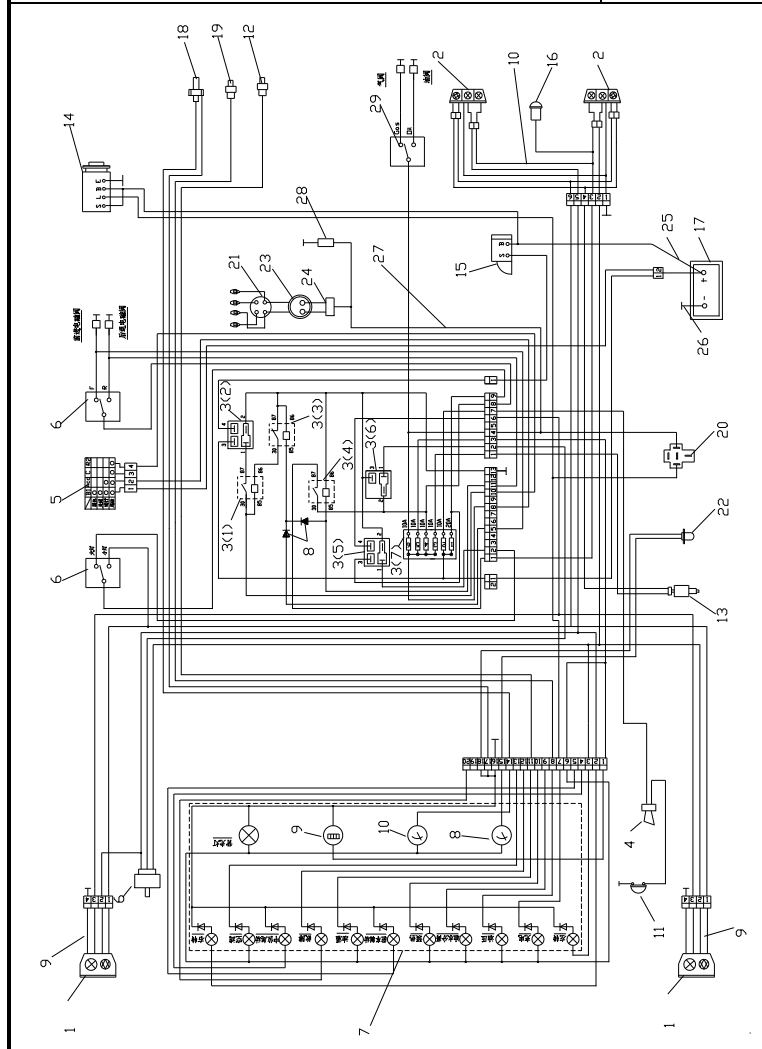

序号 Item	物料码 Part NO.	名称 Description	数量 Qty	备注或适用车型 Remarks Or Serial NO.
14	23210-50K10	发电机 12V/50A Alternator	(1)	发动机配 Supply by engine
15	23300-K9160	起动机 12V/1.2KW Starter	(1)	发动机配 Supply by engine
16	N163-700500-000	倒车报警器 Reverse warner	1	
17	R9619-700001-000	免维护蓄电池 Battery, Maintenance-free	1	12V 60Ah
17	R840-700001-000	少维护蓄电池 Battery, Low-Maintenance	1	12V 60Ah
18	XF251-700100-000	水温传感器 Water temp .sending unit	1	
19	25240-89911	油压报警器 Fuel pressure warner	(1)	发动机配 Supply by engine
20	2523079982	汽化器继电器 Carburettor relay	(1)	发动机配 Supply by engine
21	FR2A-D	火花塞 M14x1.25 spark plug	(4)	发动机配 Supply by engine
22	XF250-700400-000	油量传感器 Fule level sending unit	1	
23	T6T87778	分电器 distributor	(1)	发动机配 Supply by engine
24	T6T87778	点火线圈 ignition coil	(1)	发动机配 Supply by engine
25	XF250-702000-000	蓄电池正级引线 Battery positive cable	1	
26	N163-700200-000	蓄电池负级引线 Battery negative cable	1	
27	XF2514-710000-000	车身主线束 Main wire-harness	1	Ⓓ XF251-710000-500

图 4 电气系统
Fig.4 Electrical system

Ⓧ CPQD30/35-XW22F Ⓨ CPQD30/35-XW22B Ⓧ CPQD30/35-XW22M



图4 电气系统
Fig.4 Electrical system

Ⓧ CPQD30/35-XW22F Ⓨ CPQD30/35-XW22B Ⓦ CPQD30/35-XW22M

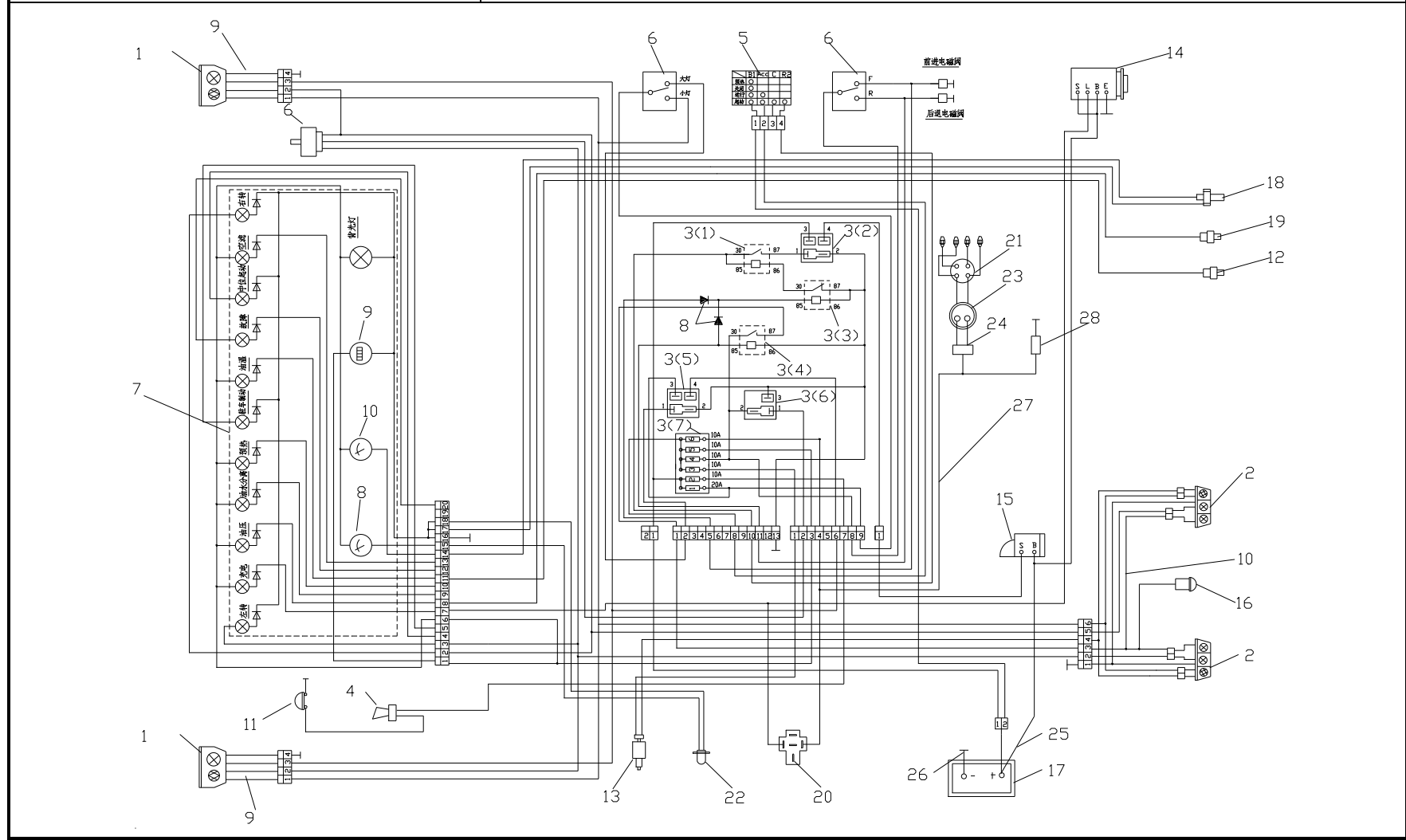
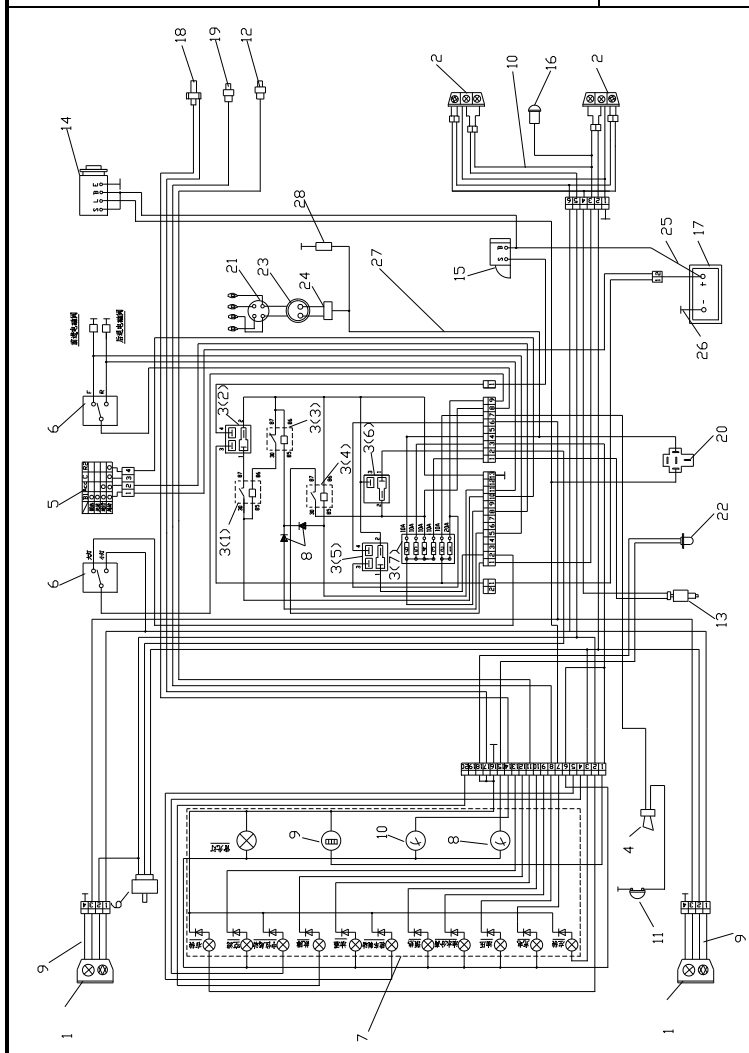

序号 Item	物料码 Part NO.	名称 Description	数量 Qty	备注或适用车型 Remarks Or Serial NO.
1	XF250-760000-000	前灯总成 front lamps assy	1	见图7 See Fig.7
2	XF250-770000-000	后灯总成 rear lamps assy	1	见图8 See Fig.8
3	XF250-706000-000	控制盒 Control box	1	见图10 See Fig.10 —2011.07
-	XF250-706000-001	控制盒 Control box	1	见图10 See Fig.10 2011.08—
4	N163-700009-000	喇叭总成 Horn assy	1	见图9 See Fig.9
5	R450-740200-000	预热起动开关 Pre-heat & start switch	1	
6	XF250-705000-000	组合开关 Combination Switch assy	1	见图12 See Fig.12
7	XF250-740000-000	组合仪表总成 Instrument assy	1	见图13 See Fig.13
8	6A60	二极管 Diode	2	
9	XF250-730000-000	前灯线束 Cable	1	≤2009-07
10	XF250-780000-000	后灯线束 Cable	1	
11		喇叭按钮 Horn button	(1)	方向盘配 Supply by steering wheel
12	XF250-700200-000	油温报警器 Fuel temperature warning	1	Ⓧ
	WG-2K(M16*1.5)-G00		(1)	Ⓨ 组合仪表配套 supply by combined
	11AB-00680		(1)	Ⓦ 变速箱配 supply by transmission box

图4 电气系统
Fig.4 Electrical system

Ⓧ CPQD30/35-XW22F Ⓨ CPQD30/35-XW22B Ⓩ CPQD30/35-XW22M

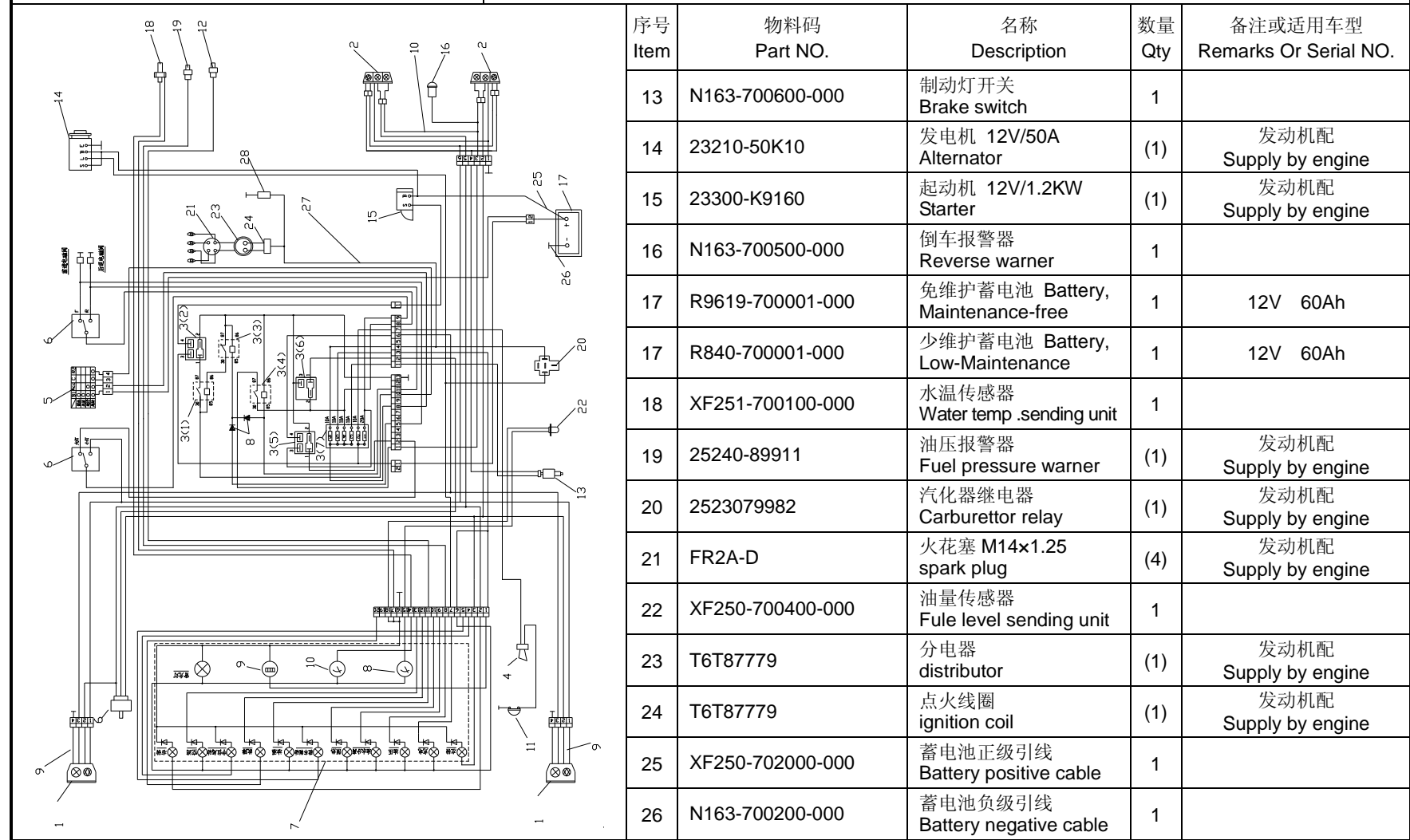

序号 Item	物料码 Part NO.	名称 Description	数量 Qty	备注或适用车型 Remarks Or Serial NO.
13	N163-700600-000	制动灯开关 Brake switch	1	
14	23210-50K10	发电机 12V/50A Alternator	(1)	发动机配 Supply by engine
15	23300-K9160	起动机 12V/1.2KW Starter	(1)	发动机配 Supply by engine
16	N163-700500-000	倒车报警器 Reverse warner	1	
17	R9619-700001-000	免维护蓄电池 Battery, Maintenance-free	1	12V 60Ah
17	R840-700001-000	少维护蓄电池 Battery, Low-Maintenance	1	12V 60Ah
18	XF251-700100-000	水温传感器 Water temp .sending unit	1	
19	25240-89911	油压报警器 Fuel pressure warner	(1)	发动机配 Supply by engine
20	2523079982	汽化器继电器 Carburettor relay	(1)	发动机配 Supply by engine
21	FR2A-D	火花塞 M14x1.25 spark plug	(4)	发动机配 Supply by engine
22	XF250-700400-000	油量传感器 Fule level sending unit	1	
23	T6T87779	分电器 distributor	(1)	发动机配 Supply by engine
24	T6T87779	点火线圈 ignition coil	(1)	发动机配 Supply by engine
25	XF250-702000-000	蓄电池正级引线 Battery positive cable	1	
26	N163-700200-000	蓄电池负级引线 Battery negative cable	1	

图4 电气系统
Fig.4 Electrical system

Ⓧ CPQD30/35-XW22F Ⓨ CPQD30/35-XW22B Ⓧ CPQD30/35-XW22M

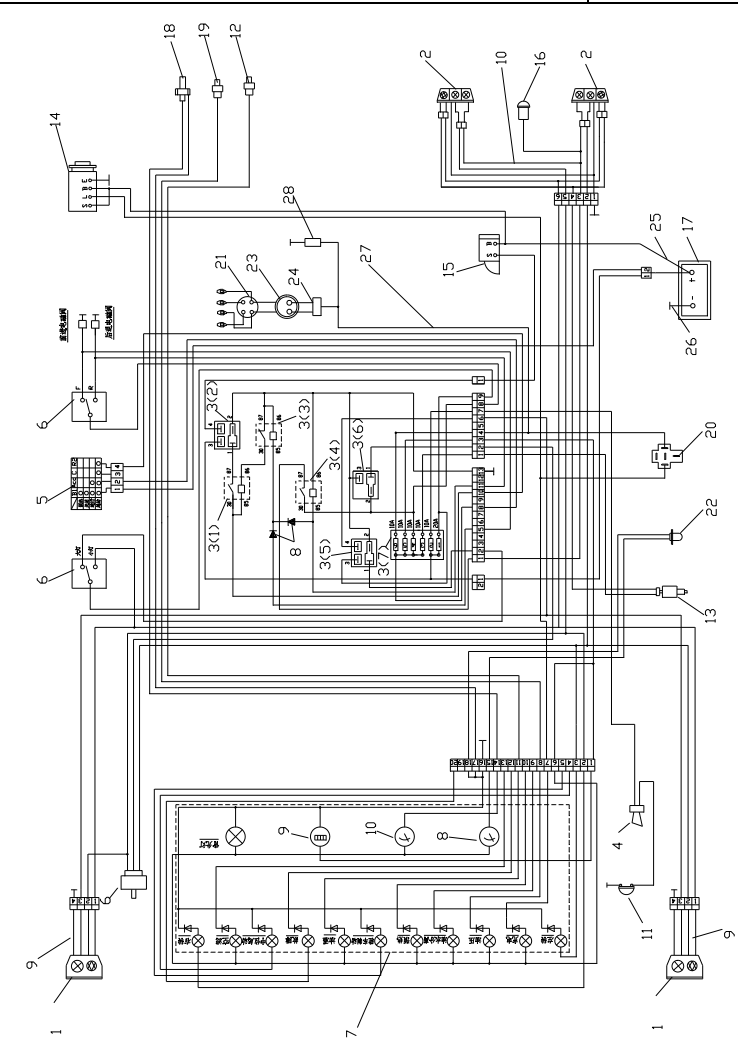

序号 Item	物料码 Part NO.	名称 Description	数量 Qty	备注或适用车型 Remarks Or Serial NO.
27	XF256-710000-000	车身主线束 Main wire-harness	1	Ⓧ ≤2011-07
27	XF256-710000-001	车身主线束 Main wire-harness	1	Ⓧ ≥2011-08
27	XB256-710000-000	车身主线束 Main wire-harness	1	Ⓨ ≤2011-07
27	XB256-710000-001	车身主线束 Main wire-harness	1	Ⓨ ≥2011-08
27	XM256-710000-000	车身主线束 Main wire-harness	1	Ⓧ ≤2011-07
27	XM256-710000-001	车身主线束 Main wire-harness	1	Ⓧ ≥2011-08
28	210030-42	汽化器 carburettor	(1)	发动机配 Supply by engine

图 5 电气系统
Fig.5 Electrical system

© CPCD30/35-XW27F



图5 电气系统
Fig.5 Electrical system

©CPCD30/35-XW27F

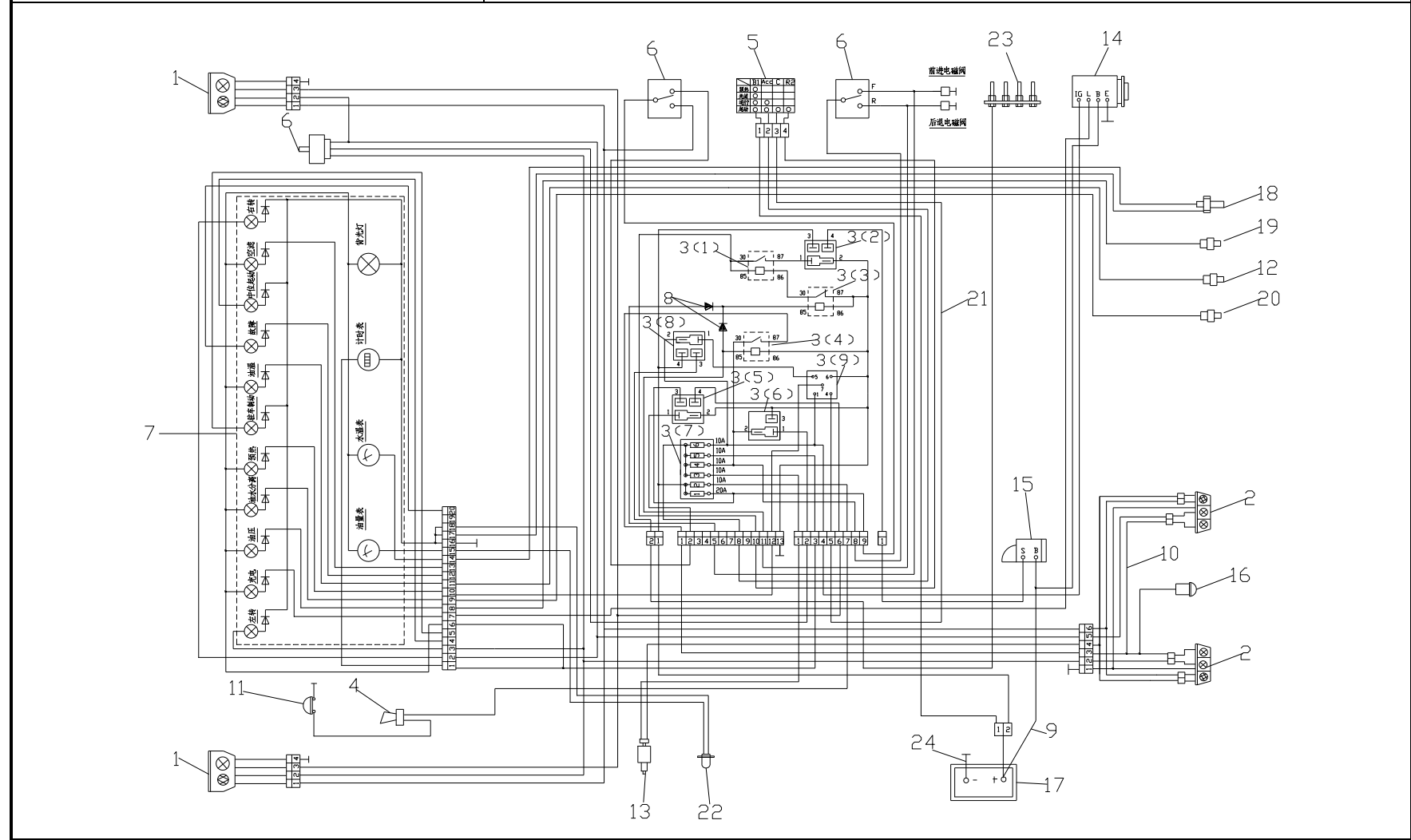
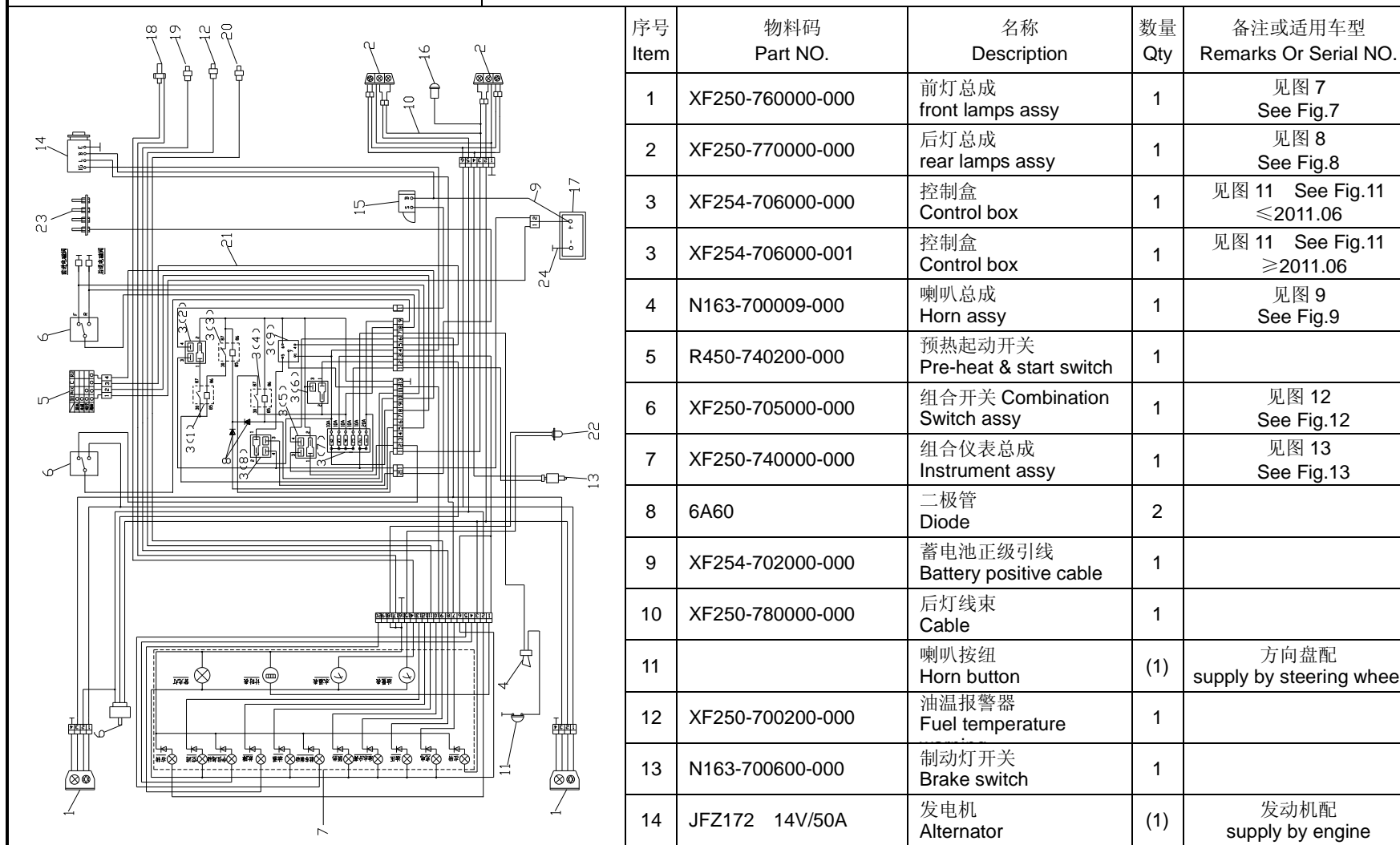

序号 Item	物料码 Part NO.	名称 Description	数量 Qty	备注或适用车型 Remarks Or Serial NO.
1	XF250-760000-000	前灯总成 front lamps assy	1	见图 7 See Fig.7
2	XF250-770000-000	后灯总成 rear lamps assy	1	见图 8 See Fig.8
3	XF254-706000-000	控制盒 Control box	1	见图 11 See Fig.11 ≤2011.06
3	XF254-706000-001	控制盒 Control box	1	见图 11 See Fig.11 ≥2011.06
4	N163-700009-000	喇叭总成 Horn assy	1	见图 9 See Fig.9
5	R450-740200-000	预热起动开关 Pre-heat & start switch	1	
6	XF250-705000-000	组合开关 Combination Switch assy	1	见图 12 See Fig.12
7	XF250-740000-000	组合仪表总成 Instrument assy	1	见图 13 See Fig.13
8	6A60	二极管 Diode	2	
9	XF254-702000-000	蓄电池正级引线 Battery positive cable	1	
10	XF250-780000-000	后灯线束 Cable	1	
11		喇叭按钮 Horn button	(1)	方向盘配 supply by steering wheel
12	XF250-700200-000	油温报警器 Fuel temperature	1	
13	N163-700600-000	制动灯开关 Brake switch	1	
14	JFZ172 14V/50A	发电机 Alternator	(1)	发动机配 supply by engine

图5 电气系统
Fig.5 Electrical system

©CPCD30/35-XW27F

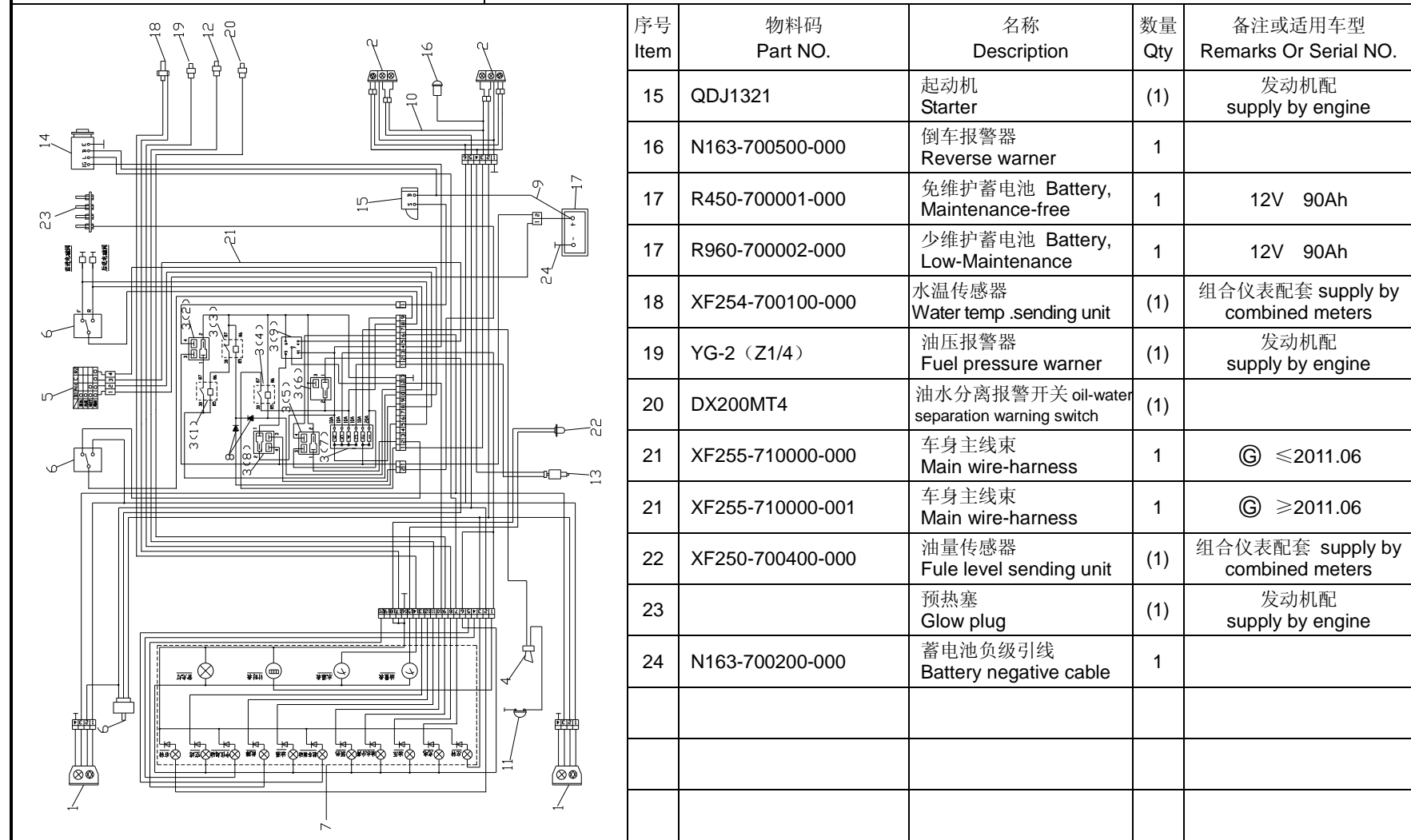

序号 Item	物料码 Part NO.	名称 Description	数量 Qty	备注或适用车型 Remarks Or Serial NO.
15	QDJ1321	起动机 Starter	(1)	发动机配 supply by engine
16	N163-700500-000	倒车报警器 Reverse warner	1	
17	R450-700001-000	免维护蓄电池 Battery, Maintenance-free	1	12V 90Ah
17	R960-700002-000	少维护蓄电池 Battery, Low-Maintenance	1	12V 90Ah
18	XF254-700100-000	水温传感器 Water temp .sending unit	(1)	组合仪表配套 supply by combined meters
19	YG-2 (Z1/4)	油压报警器 Fuel pressure warner	(1)	发动机配 supply by engine
20	DX200MT4	油水分离报警开关 oil-water separation warning switch	(1)	
21	XF255-710000-000	车身主线束 Main wire-harness	1	© ≤2011.06
21	XF255-710000-001	车身主线束 Main wire-harness	1	© ≥2011.06
22	XF250-700400-000	油量传感器 Fule level sending unit	(1)	组合仪表配套 supply by combined meters
23		预热塞 Glow plug	(1)	发动机配 supply by engine
24	N163-700200-000	蓄电池负级引线 Battery negative cable	1	

图 6 电气系统
Fig.6 Electrical system

Ⓜ CPCD30N-XW13F Ⓜ CPCD30-XW10F



图6 电气系统
Fig.6 Electrical system

Ⓜ CPCD30N-XW13F Ⓜ CPCD30-XW10F

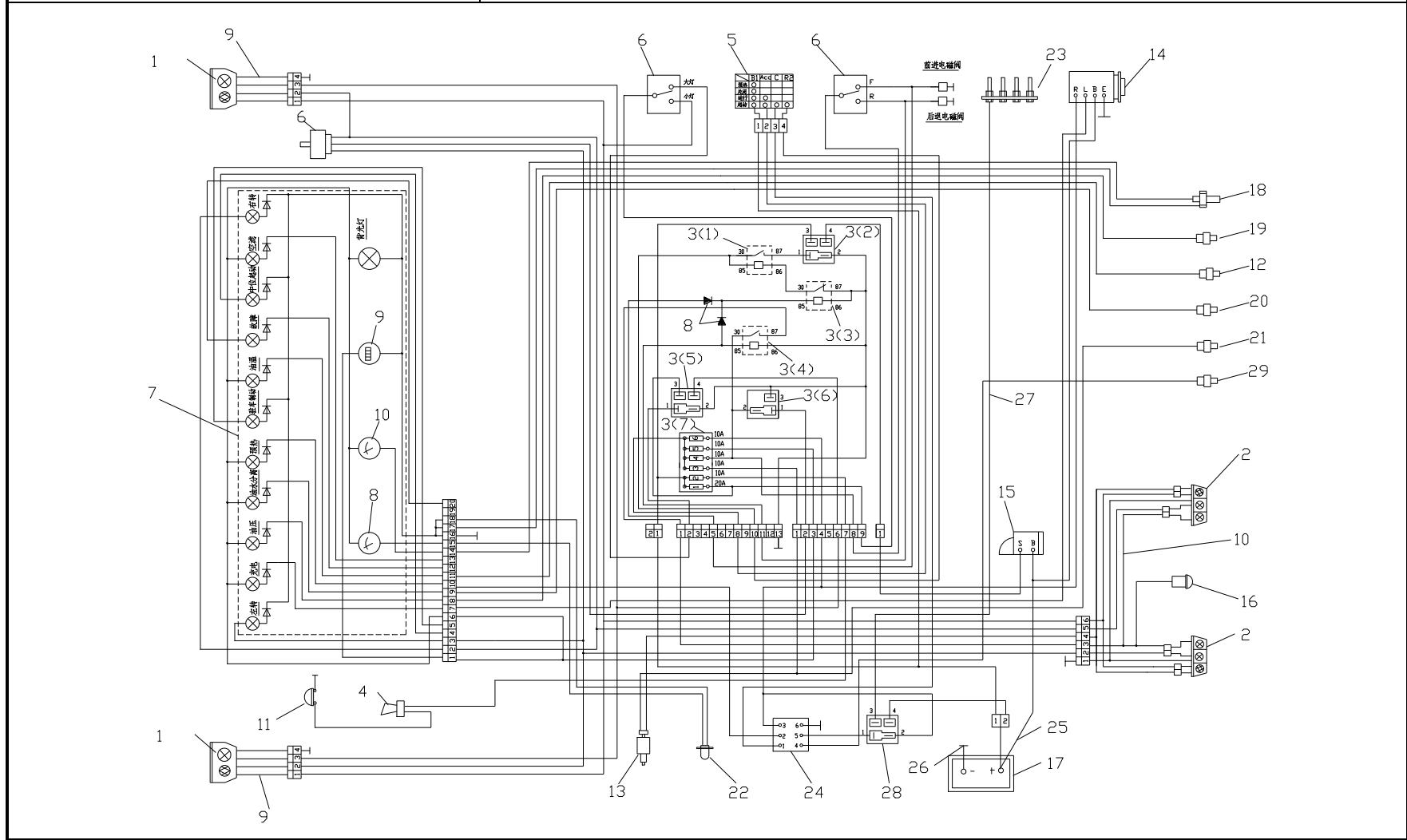
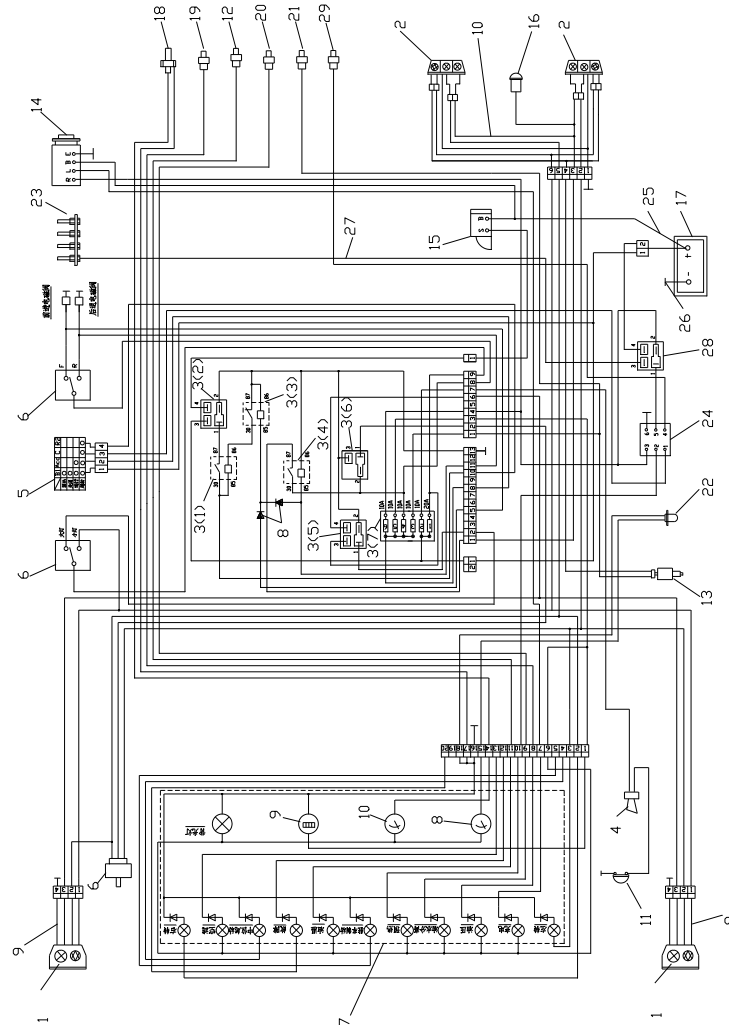

序号 Item	物料码 Part NO.	名称 Description	数量 Qty	备注或适用车型 Remarks Or Serial NO.
1	XF250-760000-000	前灯总成 front lamps assy	1	见图 7 See Fig.7
2	XF250-770000-000	后灯总成 rear lamps assy	1	见图 8 See Fig.8
3		控制盒 Control box	1	Ⓜ 见图 10 See Fig.10
3		控制盒 Control box	1	Ⓜ 见图 10 See Fig.10
4	N163-700009-000	喇叭总成 Horn assy	1	见图 9 See Fig.9
5	R450-740200-000	预热起动开关 Pre-heat & start switch	1	
6	XF250-705000-000	组合开关 Combination Switch assy	1	见图 12 See Fig.12
7	XF250-740000-000	组合仪表总成 Instrument assy	1	见图 13 See Fig.13
8	6A60	二极管 Diode	2	
9	XF250-730000-000	前灯线束 Cable	1	≤2009-07
10	XF250-780000-000	后灯线束 Cable	1	
11		喇叭按钮 Horn button	(1)	方向盘配 Supply by steering wheel
12	XF250-700200-000	油温报警器 Fuel temperature	1	
13	N163-700600-000	制动灯开关 Brake switch	1	
14	5812003411	发电机 12V/35A Alternator	(1)	发动机配 Supply by engine

图6 电气系统
Fig.6 Electrical system

Ⓜ CPCD30N-XW13F Ⓜ CPCD30-XW10F

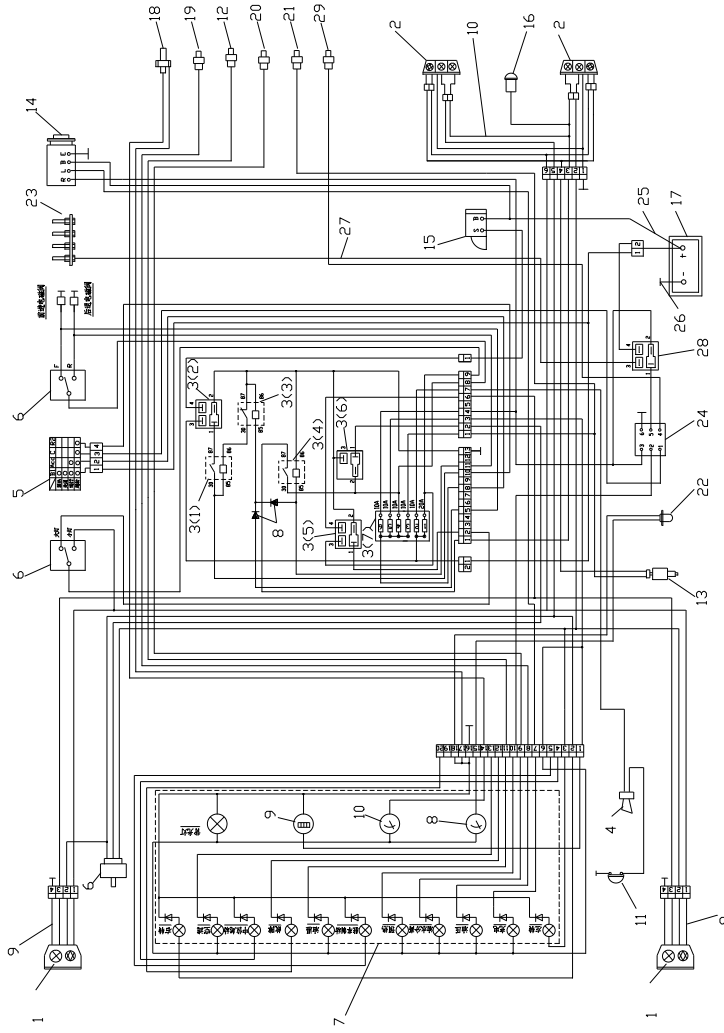

序号 Item	物料码 Part NO.	名称 Description	数量 Qty	备注或适用车型 Remarks Or Serial NO.
15	8944532120	起动机 12V/2.0KW Starter	(1)	发动机配 Supply by engine
16	N163-700500-000	倒车报警器 Reverse warner	1	
17	R450-700001-000	免维护蓄电池 Battery, Maintenance-free	1	12V 90Ah
17	R960-700002-000	少维护蓄电池 Battery, Low-Maintenance	1	12V 90Ah
18	XF250-700100-000	水温传感器 Water temp .sending unit	1	
19	5824100122	油压报警器 Fuel pressure warner	(1)	发动机配 Supply by engine
20	8943672922	油水分离报警开关 oil-water separation	(1)	发动机配 Supply by engine
21		燃油切断开关 Fuel oil supply pump	(1)	发动机配 Supply by engine
22	XF250-700400-000	油量传感器 Fule level sending unit	1	
23	89431970002	预热塞 Glow plug	(1)	发动机配 Supply by engine
24	8970405010	QGS 控制盒 12V QGS Controller 12V	(1)	发动机配 Supply by engine
25	XF250-702000-000	蓄电池正级引线 Battery positive cable	1	
26	N163-700200-000	蓄电池负级引线 Battery negative cable	1	
27	XF308-710000-000	车身主线束 Main wire-harness	1	Ⓜ

图7 前灯总成
Fig.7 front lamps assy

全部车型
All models of truck

序号 Item	物料码 Part NO.	名称 Description	数量 Qty	备注或适用车型 Remarks Or Serial NO.
A1	XF250-760000-000	前灯总成 front lamps assy	1	
1	XF250-762000-000	前灯护架 Lamp bracket	1	
2	12V/35W H3	前大灯 12V/35W Head lamp 12V/35W	1	
3	12V/4W 3893	LED 灯 LED lamp	2	
4	12V/21W 12498	转向灯 12V/21W Cornering lamp	1	
5	NO PART NO.	装饰框 Decoration frame	1	
6	NO PART NO.	灯罩 Lampshade	1	
7	NO PART NO.	连接器 Connector	1	
8	NO PART NO.	灯壳 Lamp seat	1	

图 8 后灯总成
Fig. 8 Rear lamps assy

全部车型
All models of truck

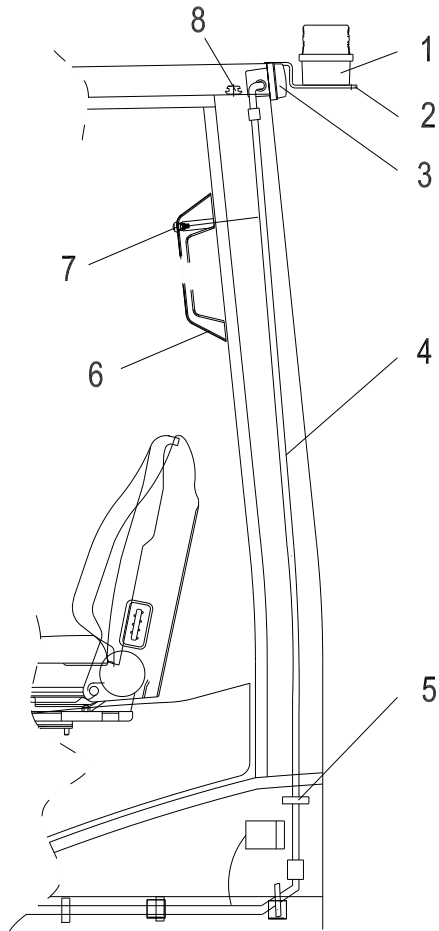

序号 Item	物料码 Part No.	名称 Description	数量 Qty	备注或适用车型 Remarks Or Serial No.
1	XF250-700010-500	警灯 Warning lamp	1	
2	XF250-800008-500	警灯支架 Warning lamp stents	1	
3	XF250-770000-000	后组合灯 Rear-combination lamps	1	See Fig.8-1
4	XF250-780000-000	后灯线束 Harness	1	
5	XF250-700005-000	后灯线护套 Harness sheath	1	
6	XF250-800009-550	扶手 Handrail	1	
7	XF250-700700-820	扶手按钮开关 Horn button	1	
8	XF250-700004-820	橡胶塞 Rubber plug	2	

图 10 控制盒总成
Fig.10 Control box assy

全部车型 (©CPCD30/35-XW27F,除外)
All models of truck (Except ©CPCD30/35-XW27F)

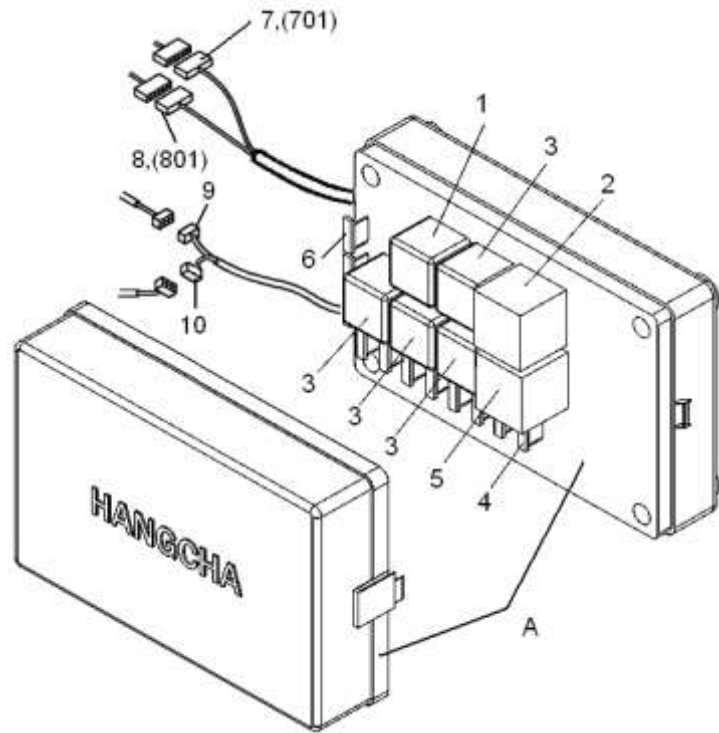

序号 Item	物料码 Part NO.	名称 Description	数量 Qty	备注或适用车型 Remarks Or Serial NO.
A1	XF250-706000-000	控制盒总成 Control box assy	1	购买前核对插头 Check the plug before buying
A2	XF250-706000-001	控制盒总成 Control box assy	1	
A3	XF3012-706000-000	控制盒总成 Control box assy	1	Ⓜ
1	HG4195A	起动继电器 Start relay	1	
2	SG152C	闪光器 Flasher	1	
3	HG4195-1	通用继电器 Universal Relay	4	
4	10A×5, 15A×2,20A×1	保险丝 Fuse	6	
5	DK-01	电子控制器 Eletronic controller	1	
6	10A×1, 15A×1,20A×1	保险丝 Fuse	3	备用 spare
7	DJ7131-3-10	十三线复合插头 13-way plug	1	A1,A3
8	DJ7091-3-10	九线复合插头 9-way plug	1	A1,A3
701	0462303	十线复合插头 10-way plug	1	A2
801	0461603	二十线复合插头 20-way plug	1	A2
9	DJ7021Y-9.5-10	二线复合插头 2-way plug	1	
10	DJ7011-7.8-10	单线复合插头 1-way plug	1	

图 11 控制盒总成
Fig.11 Control box assy

© CPCD30/35-XW27F

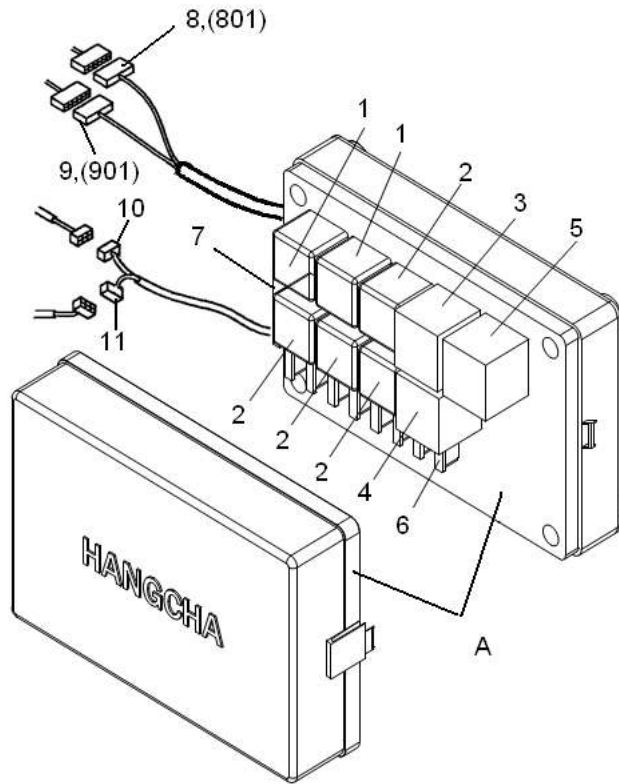

序号 Item	物料码 Part NO.	名称 Description	数量 Qty	备注或适用车型 Remarks Or Serial NO.
A3	XF254-706000-000	控制盒总成 Control box assy	1	购买前核对插头 Check the plug before buying
A4	XF254-706000-001	控制盒总成 Control box assy	1	
1	XF250-706001-000	起动继电器 Start relay	2	
2	XF250-706002-000	通用继电器 Universal Relay	4	
3	XF250-706003-000	闪光器 Flasher	1	
4	XF250-706004-000	电子控制器 Electronic controller	1	
5	YD-01	预热定时器 Time relay	(1)	发动机配套 Supply by engine
6	10A×5, 15A×2,20A×1	保险丝 Fuse	6	
7	10A×1, 15A×1,20A×1	保险丝 Fuse	3	备用 spare
8	DJ7131-3-10	十三线复合插头 13-way plug	1	A3
9	DJ7091-3-10	九线复合插头 9-way plug	1	A3
801	0462303	十线复合插头 10-way plug	1	A4
901	0461603	二十线复合插头 20-way plug	1	A4
10	DJ7021Y-9.5-10	二线复合插头 2-way plug	1	
11	DJ7011-7.8-10	单线复合插头 1-way plug	1	

图 13 组合仪表总成
Fig. 13 Instrument assy

全部车型
All models of truck

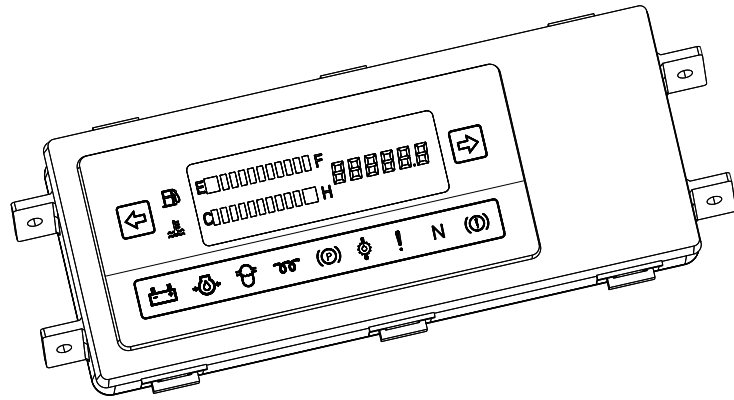

序号 Item	物料码 Code No.	名称 Description	数量 Qty	备注或适用车型 Remarks Or Serial No.
A	XF250-740000-000	组合仪表总成 Instrument assy	1	

图 14 电气系统 (CE)
Fig.14 Electrical system (CE)

Ⓐ CPYD30/35-XW22F Ⓑ CPYD30/35-XW22B Ⓒ CPYD30/35-XW22M



图 14 电气系统 (CE)
Fig.14 Electrical system (CE)

Ⓓ CPYD30/35-XW22F Ⓔ CPYD30/35-XW22B Ⓕ CPYD30/35-XW22M

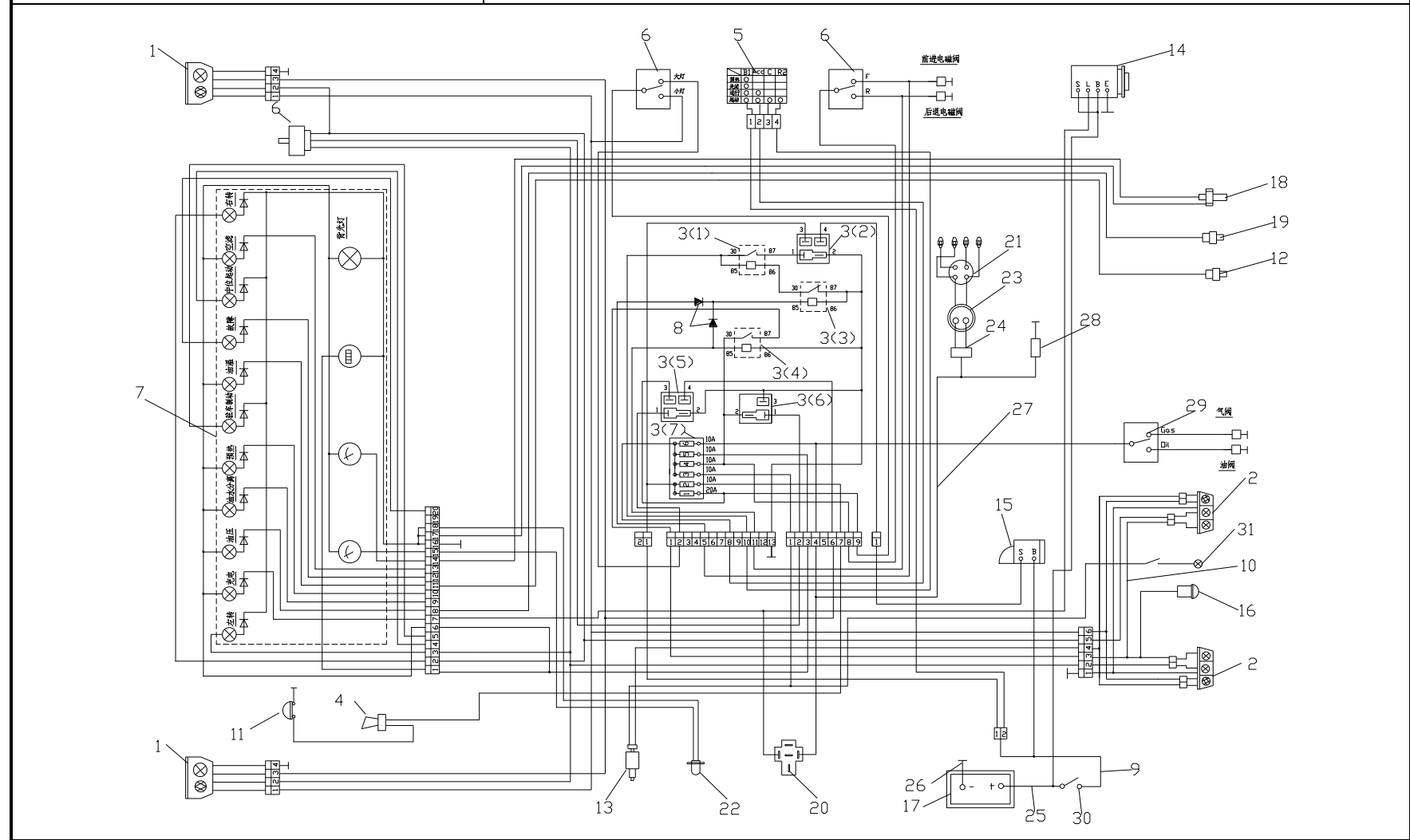
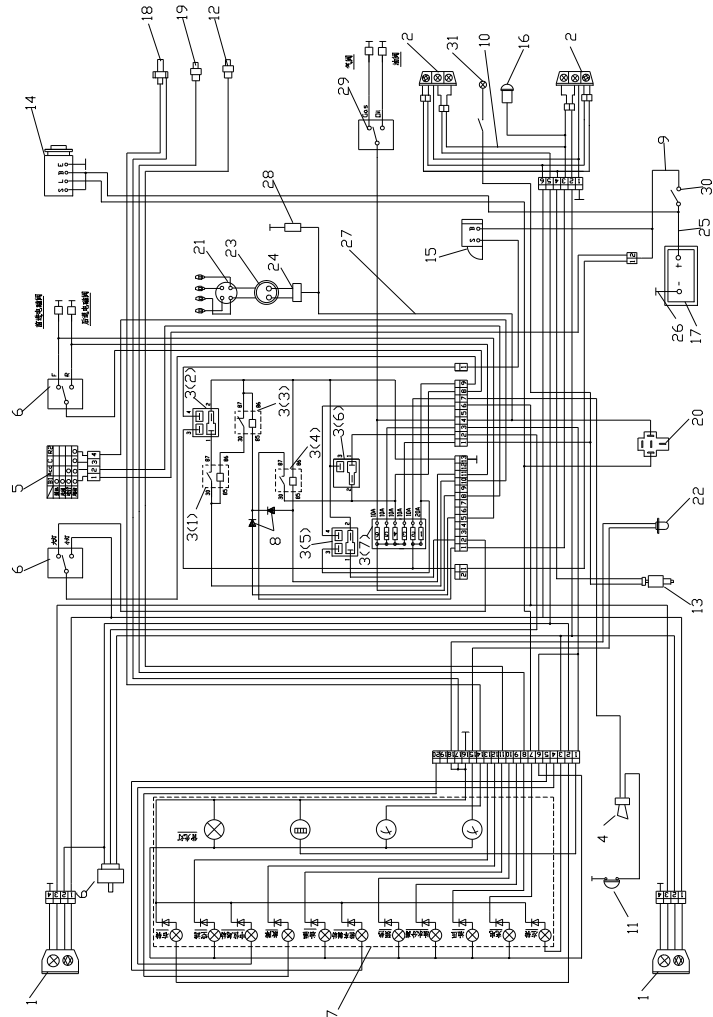

序号 Item	物料码 Part NO.	名称 Description	数量 Qty	备注或适用车型 Remarks Or Serial NO.
1	XF250-760000-000	前灯总成 front lamps assy	1	见图 7 See Fig.7
2	XF250-770000-000	后灯总成 rear lamps assy	1	见图 8 See Fig.8
3		控制盒 Control box	1	见图 10 See Fig.10
4	N163-700009-000	喇叭总成 Horn assy	1	见图 9 See Fig.9
5	R450-740200-000	预热起动开关 Pre-heat & start switch	1	
6	XF250-705000-000	组合开关 Combination Switch assy	1	见图 12 See Fig.12
7	XF250-740000-000	组合仪表总成 Instrument assy	1	见图 13 See Fig.13
8	6A60	二极管 Diode	2	
9	XF250-700300-820	电源开关线接起动机线 On-off switches line	1	
10	XF250-780000-000	后灯线束 Cable	1	
11		喇叭按钮 Horn button	(1)	方向盘配 Supply by steering wheel
12	XF250-700200-000	油温报警器 Fuel temperature warning	(1)	Ⓓ 组合仪表配套 Supply by combined meters
	WG-2K(M16*1.5)-G00		(1)	Ⓔ 组合仪表配套 Supply by combined meters
	11AB-00680		(1)	Ⓕ 变速箱配 Supply by transmission box
13	N163-700600-000	制动灯开关 Brake switch	1	

图 14 电气系统 (CE)
Fig.14 Electrical system (CE)

Ⓓ CPYD30/35-XW22F Ⓔ CPYD30/35-XW22B Ⓕ CPYD30/35-XW22M

序号 Item	物料码 Part NO.	名称 Description	数量 Qty	备注或适用车型 Remarks Or Serial NO.
14	23210-50K10	发电机 12V/50A Alternator	(1)	发动机配 Supply by engine
15	23300-K9160	起动机 12V/1.2KW Starter	(1)	发动机配 Supply by engine
16	N163-700500-000	倒车报警器 Reverse warner	1	
17	R9619-700001-000	免维护蓄电池 Battery, Maintenance-free	1	12V 60Ah
-	R840-700001-000	少维护蓄电池 Battery, Low-Maintenance	1	12V 60Ah
18	XF251-700100-000	水温传感器 Water temp .sending unit	1	
19	25240-89911	油压报警器 Fuel pressure warner	(1)	发动机配 Supply by engine
20	2523079982	汽化器继电器 Carburettor relay	(1)	发动机配 Supply by engine
21	FR2A-D	火花塞 M14×1.25 spark plug	(4)	发动机配 Supply by engine
22	XF250-700400-000	油量传感器 Fule level sending unit	1	
23	T6T87778	分电器 distributor	(1)	发动机配 Supply by engine
24	T6T87778	点火线圈 ignition coil	(1)	发动机配 Supply by engine
25	XF250-70200-820	蓄电池接电源开关线 On-off switches line	1	
26	N163-700200-820	蓄电池负级引线 Battery negative cable	1	
27	XF251-710000-850	车身主线束 Cable	1	Ⓓ ≤2011-07

图 14 电气系统 (CE)
Fig.14 Electrical system (CE)

Ⓓ CPYD30/35-XW22F Ⓔ CPYD30/35-XW22B Ⓕ CPYD30/35-XW22M

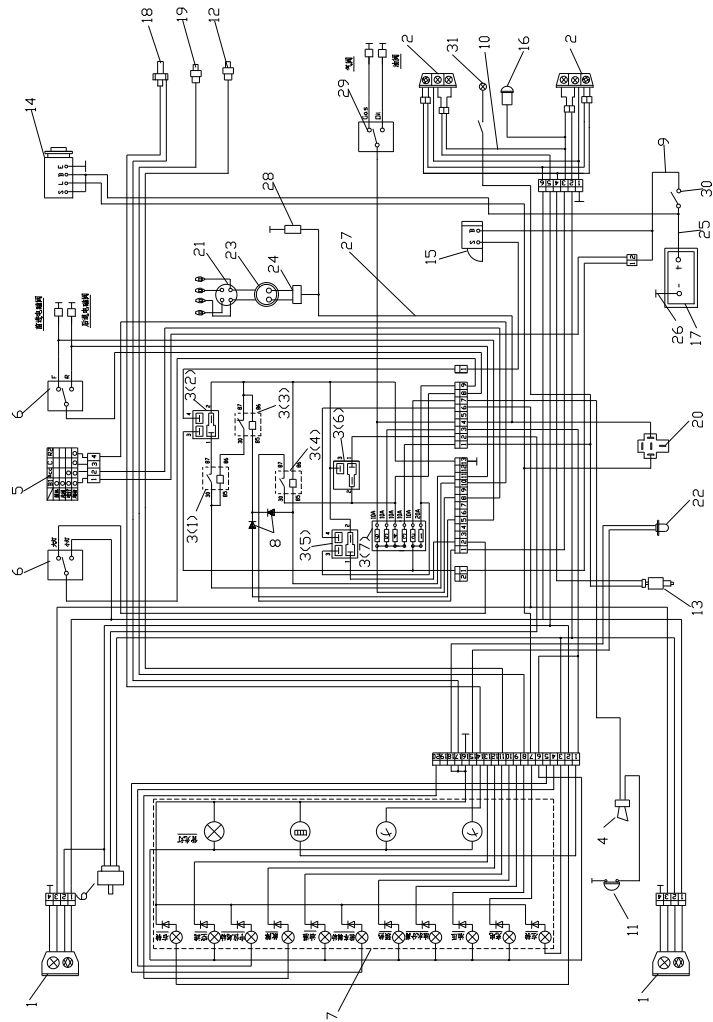

序号 Item	物料码 Part NO.	名称 Description	数量 Qty	备注或适用车型 Remarks Or Serial NO.
27	XF251-710000-851	车身主线束 Cable	1	Ⓓ ≥2011-08
27	XB251-710000-850	车身主线束 Main wire-harness	1	Ⓔ ≤2011-07
27	XB251-710000-851	车身主线束 Main wire-harness	1	Ⓔ ≥2011-08
27	XM251-710000-850	车身主线束 Main wire-harness	1	Ⓕ ≤2011-07
27	XM251-710000-851	车身主线束 Main wire-harness	1	Ⓕ ≥2011-08
28	210030-42	汽化器 carburettor	(1)	双燃料叉车配、发动机配 For dual fuel & Supply by
29	JK931-146	双燃料选择开关 For dual fuel Selection switch	1	双燃料叉车配 For dual fuel
30	XF250-704000-820	紧急断电开关总成 Urgent cut out switch	1	
31	XF250-700010-500	警灯 Warning lamp	1	

图 15 电气系统 (CE)
Fig.15 Electrical system (CE)

Ⓐ CPCD30/35-XW33F Ⓑ CPCD30/35-XW33B Ⓒ CPCD30/35-XW33M



图 15 电气系统 (CE) Fig.15 Electrical system (CE)		Ⓐ CPCD30/35-XW33F Ⓑ CPCD30/35-XW33B Ⓒ CPCD30/35-XW33M		
序号 Item	物料码 Part NO.	名称 Description	数量 Qty	备注或适用车型 Remarks Or Serial NO.
E04		预热塞 Glow plug	(1)	发动机配套 Supply by engine
F1-F2	50A	保险丝 Fuse	2	
G1	R450-700001-000	免维护蓄电池 Battery, Maintenance-free	1	12V 90Ah
-	R960-700002-000	少维护蓄电池 Battery, Low-Maintenance	1	12V 90Ah
G2		发电机 Alternator	(1)	发动机配套 Supply by engine
H1-H2	XF250-760100-000	前小灯 Front lamps	2	见图 7 See Fig.7
H3-H4	XF250-760100-000	前大灯 Rear lamps	2	见图 7 See Fig.7
H5-H6	XF250-770000-000	后组合灯 Combination tail lamp	2	见图 8 See Fig.8
H8	XF250-700010-500	警灯 Warning lamp	1	见图 8 See Fig.8
H09	12V/2W	预热指示灯 Preheat indicator lamp	(1)	组合仪表配套 Combination meter
H10	12V/2W	充电指示灯 Charge indicator lamp	(1)	组合仪表配套 Combination meter
H11	12V/2W	油压指示灯 Oil pressure indicator lamp	(1)	组合仪表配套 Combination meter
H12	12V/2W	油温指示灯 Oil temperature indicator lamp	(1)	组合仪表配套 Combination meter
H13	12V/2W	油水分离指示灯 Oil-water separator indicator lamp	(1)	发动机配套 Supply by engine
H01	N163-700009-000	电喇叭 Horn	1	见图 9 See Fig.9

图 15 电气系统 (CE) Fig.15 Electrical system (CE)		Ⓐ CPCD30/35-XW33F Ⓑ CPCD30/35-XW33B Ⓒ CPCD30/35-XW33M		
序号 Item	物料码 Part NO.	名称 Description	数量 Qty	备注或适用车型 Remarks Or Serial NO.
H02	N163-700500-000	倒车报警器 Reverse warner	1	
K12	XF250-706002-000	倒车喇叭继电器 Reverse Horn relay	1	
M1		起动机 Starter	(1)	发动机配套 Supply by engine
P1		水温表 Water temperature gauge	(1)	组合仪表配套 Combination meter
P2		油量表 Fuel quantity gauge	(1)	组合仪表配套 Combination meter
P3		计时表 Timer	(1)	组合仪表配套 Combination meter
QGS	129930-77970	QGS 控制盒 Control box	(1)	发动机配套 Supply by engine
S1	XF250-705000-000	组合开关总成 Combination Switch assy	1	见图 12 See Fig.12
S2	JK106-G00	警示灯开关 Warning lamp switch	1	
S3	N163-700600-000	制动灯开关 Brake switch	1	
S4		喇叭按钮 Horn button	(1)	方向盘 Supply by steering wheel
S7	R450-740200-000	预热启动开关 Pre-heat & start switch	1	
S8	XF250-704000-820	紧急断电开关 Master disconnect	1	
S15	XF250-700700-820	倒车扶手按钮 Reverse handrail button	1	
S101	25240-89911	油压传感器 Oil pressure sensor	(1)	发动机配套 Supply by engine

图 15 电气系统 (CE) Fig.15 Electrical system (CE)		Ⓐ CPCD30/35-XW33F Ⓑ CPCD30/35-XW33B Ⓒ CPCD30/35-XW33M		
序号 Item	物料码 Part NO.	名称 Description	数量 Qty	备注或适用车型 Remarks Or Serial NO.
S102	XF250-700100-000	水温传感器 Water temperature sensor	(1)	组合仪表配套 Combination meter
S103	XF250-700400-000	油量传感器 Fuel quantity sensor	(1)	组合仪表配套 Combination meter
S104	129917-55800	油水分离报警灯 Oil-water separator indicator lamp	(1)	发动机配套 Supply by engine
S105	XF250-700200-000	油温传感器 Oil temperature sensor	(1)	组合仪表配套 Combination meter
S107		水温传感器 Water temperature sensor	(1)	发动机配套 upply by engine
Y1		前进电磁阀 Forward solenoid valve	(1)	变速箱配套 Supply by transmission box
Y2		倒车电磁阀 Reverse solenoid valve	(1)	变速箱配套 Supply by transmission box
Y3		燃油切断电磁阀 Fuel shut off solenoid valve	(1)	变速箱配套 Supply by transmission box
Y5		时间电磁阀 Timer solenoid	(1)	发动机配 Supply by engine
线号 001	XF250-702000-820	蓄电池接电源开关线 Battery to Master disconnect	1	
线号 002	XF250-700300-820	电源开关线接起动机线 Master disconnect to Starter	1	
线号 003- 036	XF250-710000-820	车身主线束 Main wire-harness	1	Ⓐ ≤2011.08
线号 003- 036	XF250-710000-821	车身主线束 Main wire-harness	1	Ⓐ ≥2011.09
线号 003- 036	XB250-710000-820	车身主线束 Main wire-harness	1	Ⓑ ≤2011.06
线号 003- 036	XB250-710000-821	车身主线束 Main wire-harness	1	Ⓑ ≥2011.07

图 15 电气系统 (CE)
Fig.15 Electrical system (CE)

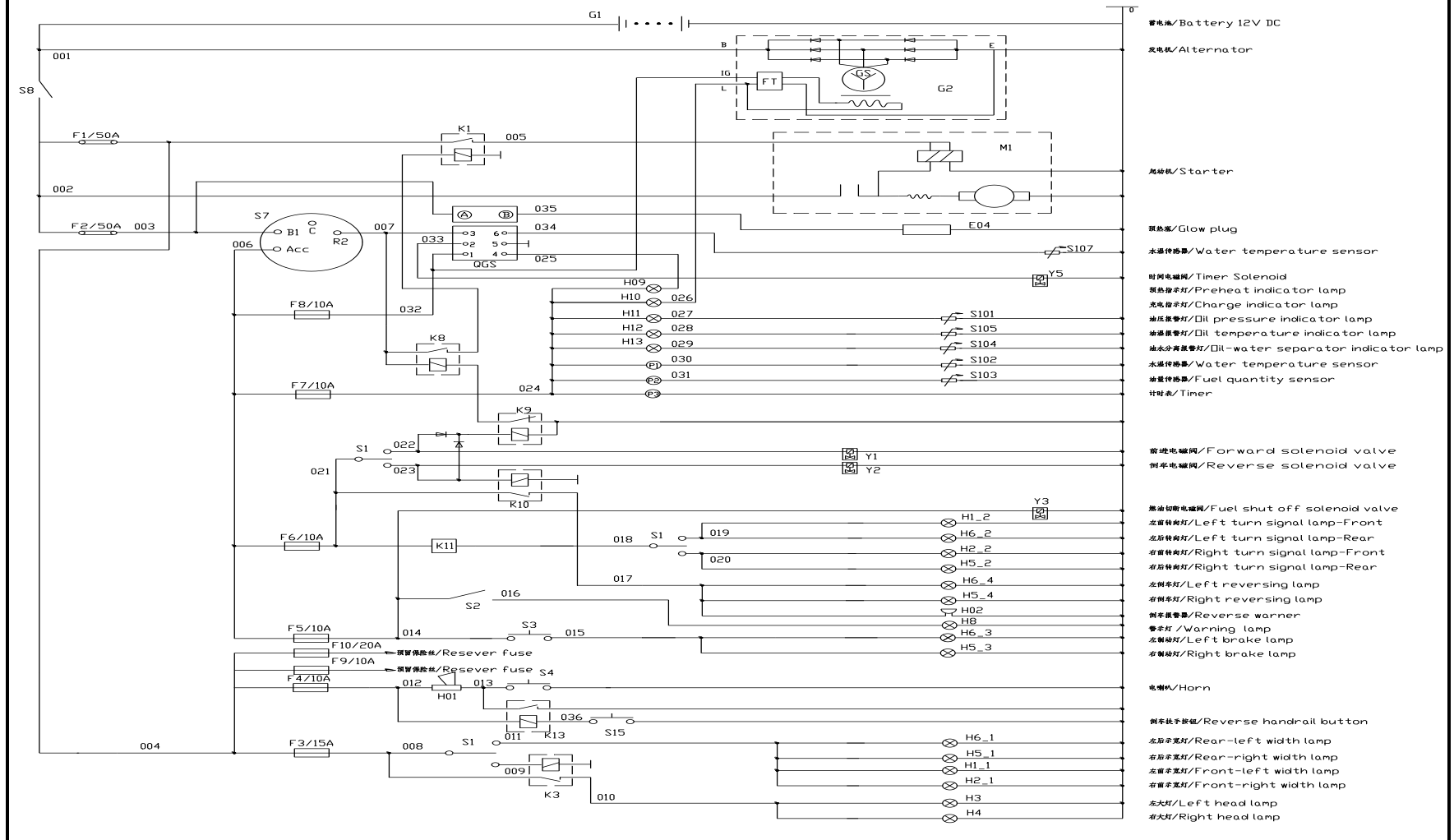
Ⓐ CPCD30/35-XW33F Ⓑ CPCD30/35-XW33B Ⓒ CPCD30/35-XW33M

序号 Item	物料码 Part NO.	名称 Description	数量 Qty	备注或适用车型 Remarks Or Serial NO.
线号 003- 036	XM250-710000-820	车身主线束 Main wire-harness	1	Ⓒ ≤2011.07
线号 003- 036	XM250-710000-821	车身主线束 Main wire-harness	1	Ⓒ ≥2011.08
线号 0	R960-700300-820	起动机接地线 Starter to earth wire	1	
线号 0	N163-700200-820	蓄电池负极引线 Battery negative cable	1	

图 16 电气系统 (CE)
Fig.16 Electrical system (CE)

© CPCD30/35-XW27F



图 16 电气系统 (CE) Fig.16 Electrical system (CE)		© CPCD30/35-XW27F		
序号 Item	物料码 Part NO.	名称 Description	数量 Qty	备注或适用车型 Remarks Or Serial NO.
E04		预热塞 Glow plug	(1)	发动机配套 Supply by engine
F1-F2	50A	保险丝 Fuse	2	
G1	R450-700001-000	免维护蓄电池 Battery, Maintenance-free	1	12V 90Ah
G1	R960-700002-000	少维护蓄电池 Battery, Low-Maintenance	1	12V 90Ah
G2		发电机 Alternator	(1)	发动机配套 Supply by engine
H1-H2	XF250-760100-000	前小灯 Front lamps	2	见图 7 See Fig.7
H3-H4	XF250-760100-000	前大灯 Rear lamps	2	见图 7 See Fig.7
H5-H6	XF250-770000-000	后组合灯 Combination tail lamp	2	见图 8 See Fig.8
H8	XF250-700010-500	警灯 Warning lamp	1	见图 8 See Fig.8
H09	12V/2W	预热指示灯 Preheat indicator lamp	(1)	组合仪表配套 Combination meter
H10	12V/2W	充电指示灯 Charge indicator lamp	(1)	组合仪表配套 Combination meter
H11	12V/2W	油压指示灯 Oil pressure indicator lamp	(1)	组合仪表配套 Combination meter
H12	12V/2W	油温指示灯 Oil temperature indicator lamp	(1)	组合仪表配套 Combination meter
H13	12V/2W	油水分离指示灯 Oil-water separator indicator lamp	(1)	组合仪表配套 Combination meter
H01	N163-700009-000	电喇叭 Horn	1	见图 9 See Fig.9

图 16 电气系统 (CE)
Fig.16 Electrical system (CE)

© CPCD30/35-XW27F

序号 Item	物料码 Part NO.	名称 Description	数量 Qty	备注或适用车型 Remarks Or Serial NO.
H02	N163-700500-000	倒车报警器 Reverse warner	1	
K12	XF250-706002-000	倒车喇叭继电器 Reverse Horn relay	1	
M1		起动机 Starter	(1)	发动机配套 Supply by engine
P1		水温表 Water temperature gauge	(1)	组合仪表配套 Combination meter
P2		油量表 Fuel quantity gauge	(1)	组合仪表配套 Combination meter
P3		计时表 Timer	(1)	组合仪表配套 Combination meter
S1	XF250-705000-000	组合开关 Combination Switch assy	1	
S2	JK106-G00	警示灯开关 Warning lamp switch	1	
S3	N163-700600-000	制动灯开关 Brake switch	1	
S4		喇叭按钮 Horn button	(1)	方向盘 Supply by steering wheel
S7	R450-740200-000	预热起动开关 Pre-heat & start switch	1	
S8	XF250-704000-820	紧急断电开关 Master disconnect	1	
S15	XF250-700700-820	倒车扶手按钮 Reverse handrail button	1	
S101	25240-89911	油压传感器 Oil pressure sensor	(1)	发动机配套 Supply by engine
S102	XF254-700100-000	水温传感器 Water temperature sensor	(1)	组合仪表配套 Combination meter

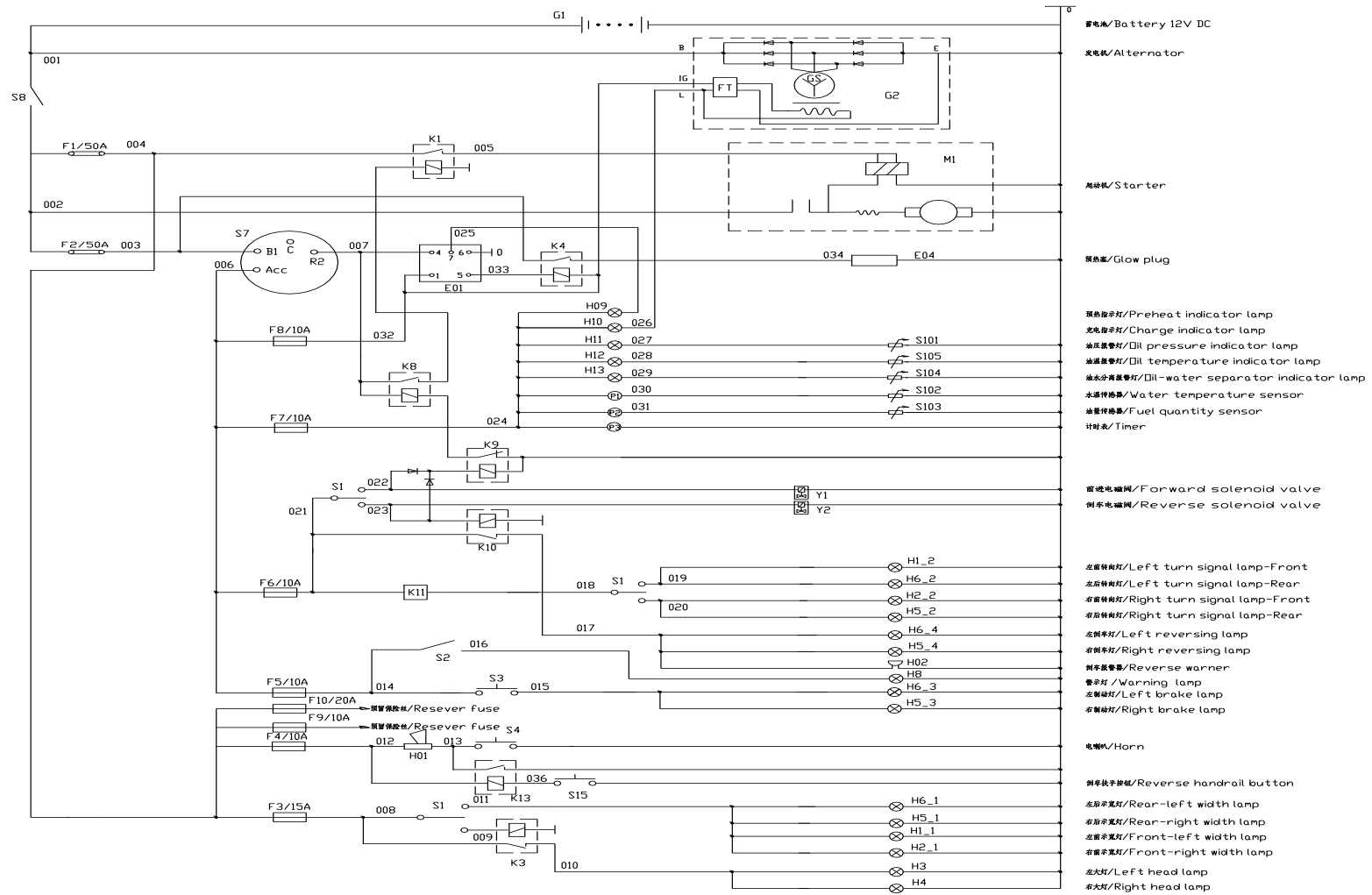
图 16 电气系统 (CE)
Fig.16 Electrical system (CE)

© CPCD30/35-XW27F

序号 Item	物料码 Part NO.	名称 Description	数量 Qty	备注或适用车型 Remarks Or Serial NO.
S103	XF250-700400-000	油量传感器 Fuel quantity sensor	(1)	组合仪表配套 Combination meter
S104	DX200MT4	油水分离报警灯 Oil-water separator indicator lamp	1	
S105	XF250-700200-000	油温传感器 Oil temperature sensor	1	
Y1		前进电磁阀 Forward solenoid valve	(1)	变速箱配套 Supply by transmission box
Y2		倒车电磁阀 Reverse solenoid valve	(1)	变速箱配套 Supply by transmission box
线号 001	XF250-702000-820	蓄电池接电源开关线 Battery to Master disconnect	1	
线号 002	XF254-700300-820	电源开关线接起动机线 Master disconnect to Starter	1	
线号 003- 034	XF255-710000-820	车身主线束 Main wire-harness	1	≤2011-09
线号 003- 034	XF255-710000-821	车身主线束 Main wire-harness	1	≥2011-10
线号 0	R960-700300-820	起动机接地线 Starter to earth wire	1	
线号 0	N163-700200-820	蓄电池负极引线 Battery negative cable	1	

图 17 电气系统 (CE)
Fig.17 Electrical system (CE)

① CPCD30/35-XW10F



图 17 电气系统 (CE) Fig.17 Electrical system (CE)		① CPCD30/35-XW10F		
序号 Item	物料码 Part NO.	名称 Description	数量 Qty	备注或适用车型 Remarks Or Serial NO.
F1-F2	50A	保险丝 Fuse	2	
G1	R450-700001-000	免维护蓄电池 Battery, Maintenance-free	1	12V 90Ah
G1	R960-700002-000	少维护蓄电池 Battery, Low-Maintenance	1	12V 90Ah
G2	5812003411	发电机 Alternator	(1)	发动机配套 Supply by engine
H1-H2	XF250-760100-000	前小灯 Front lamps	2	见图 7 See Fig.7
H3-H4	XF250-760100-000	前大灯 Rear lamps	2	见图 7 See Fig.7
H5-H6	XF250-770000-000	后组合灯 Combination tail lamp	2	见图 8 See Fig.8
H8	XF250-700010-500	警灯 Warning lamp	1	见图 8 See Fig.8
H9	12V/2W	预热指示灯 Preheat lamp	(1)	组合仪表配套 Combination meter
H10	12V/2W	充电指示灯 Charge indicator lamp	(1)	组合仪表配套 Combination meter
H11	12V/2W	油压指示灯 Oil pressure indicator lamp	(1)	发动机配套 Supply by engine
H12	12V/2W	油温指示 Oil temperature indicator lamp	(1)	组合仪表配套 Combination meter
H13	12V/2W	油水分离报警灯 Water-oil seperation lamp	(1)	组合仪表配套 Combination meter
H01	N163-700009-000	电喇叭 Horn	1	见图 9 See Fig.9
H02	N163-700500-000	倒车报警器 Reverse warner	1	

图 17 电气系统 (CE)
Fig.17 Electrical system (CE)

① CPCD30/35-XW10F

序号 Item	物料码 Part NO.	名称 Description	数量 Qty	备注或适用车型 Remarks Or Serial NO.
K4	8942481610	预热继电器 Preheat relay	(1)	发动机配套 Supply by engine
K12	XF250-706002-000	倒车喇叭继电器 Reverse Horn relay	1	
M1	8944532120	起动机 Starter	(1)	发动机配套 Supply by engine
P1		水温表 Water temperature gauge	(1)	组合仪表配套 Combination meter
P2		油量表 Fule level gauge	(1)	组合仪表配套 Combination meter
P3		计时表 Timer	(1)	组合仪表配套 Combination meter
S1	XF250-705000-000	组合开关 Combination Switch assy	1	
S2	JK106-G00	警示灯开关 Warning lamp switch	1	
S3	N163-700600-000	制动灯开关 Brake switch	1	
S4		喇叭按钮 Horn button	(1)	方向盘 Supply by steering wheel
S7	R450-740200-000	预热起动开关 Pre-heat & start switch	1	
S8	XF250-704000-820	紧急断电开关 Master disconnect	1	
S15	XF250-700700-820	倒车扶手按钮 Reverse handrail button	1	
S101	5824100122	油压传感器 Oil pressure sensor	(1)	发动机配套 Supply by engine
S102	XF250-700100-000	水温传感器 Water temperature sensor	1	

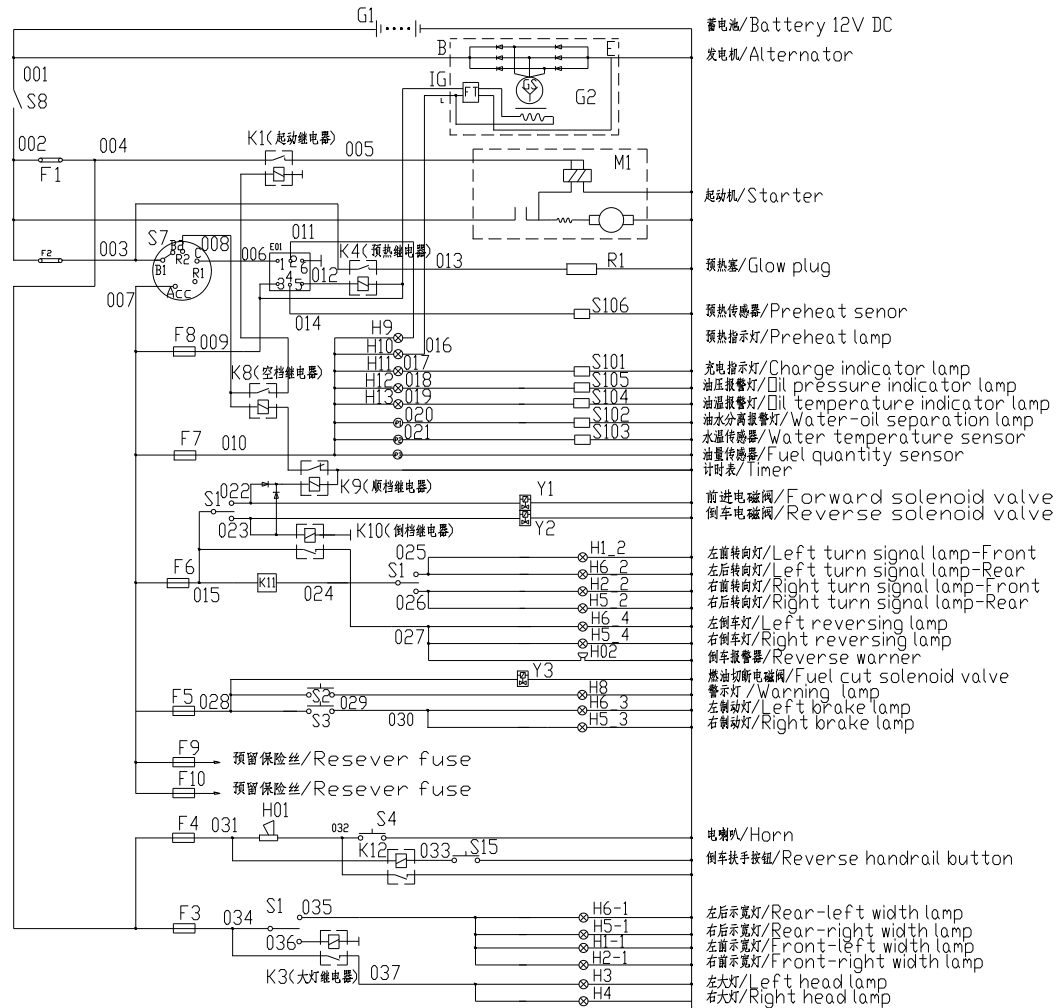
图 17 电气系统 (CE) Fig.17 Electrical system (CE)		① CPCD30/35-XW10F		
序号 Item	物料码 Part NO.	名称 Description	数量 Qty	备注或适用车型 Remarks Or Serial NO.
S103	XF250-700400-000	油量传感器 Fule level sending unit	1	
S104	8943672922	油水分离报警器 Water-oil seperation warning	(1)	发动机配套 Supply by engine
S105	XF250-700200-000	油温报警器 Fuel temperature warning	(1)	组合仪表配套 Supply by combined meters
S106	8970697861	预热传感器 Preheat sensor	(1)	发动机配套 Supply by engine
Y1		前进电磁阀 Forward solenoid valve	(1)	变速箱配套 Supply by transmission box
Y2		倒车电磁阀 Reverse solenoid valve	(1)	变速箱配套 Supply by transmission box
Y3		燃油切断电磁阀 Fuel cut solenoid valve	(1)	发动机配套 Supply by engine
R1	8943197002	预热塞 Glow plug	(1)	发动机配套 Supply by engine
E01	8970405010	QGS 控制器 QGS controller	(1)	发动机配套 Supply by engine
线号 001	XF250-702000-820	蓄电池接电源开关线 Battery to Master disconnect	1	
线号 002	XF250-700300-820	电源开关线接起动机线 Master disconnect to Starter	1	
003-037	XF308-710000-820	车身主线束 Main wire-harness	1	① ≤2011-08
003-037	XF308-710000-821	车身主线束 Main wire-harness	1	① ≥2011-09
线号 0	R960-700300-820	起动机接地线 Starter to earth wire	1	
线号 0	N163-700200-820	蓄电池负极引线 Battery negative cable	1	

图 18 电气系统 (CE)
Fig.18 Electrical system (CE)

Ⓧ CPQD30/35-XW22F Ⓨ CPQD30/35-XW22B Ⓧ CPQD30/35-XW22M



图 18 电气系统 (CE)
Fig.18 Electrical system (CE)

Ⓧ CPQD30/35-XW22F Ⓨ CPQD30/35-XW22B Ⓩ CPQD30/35-XW22M

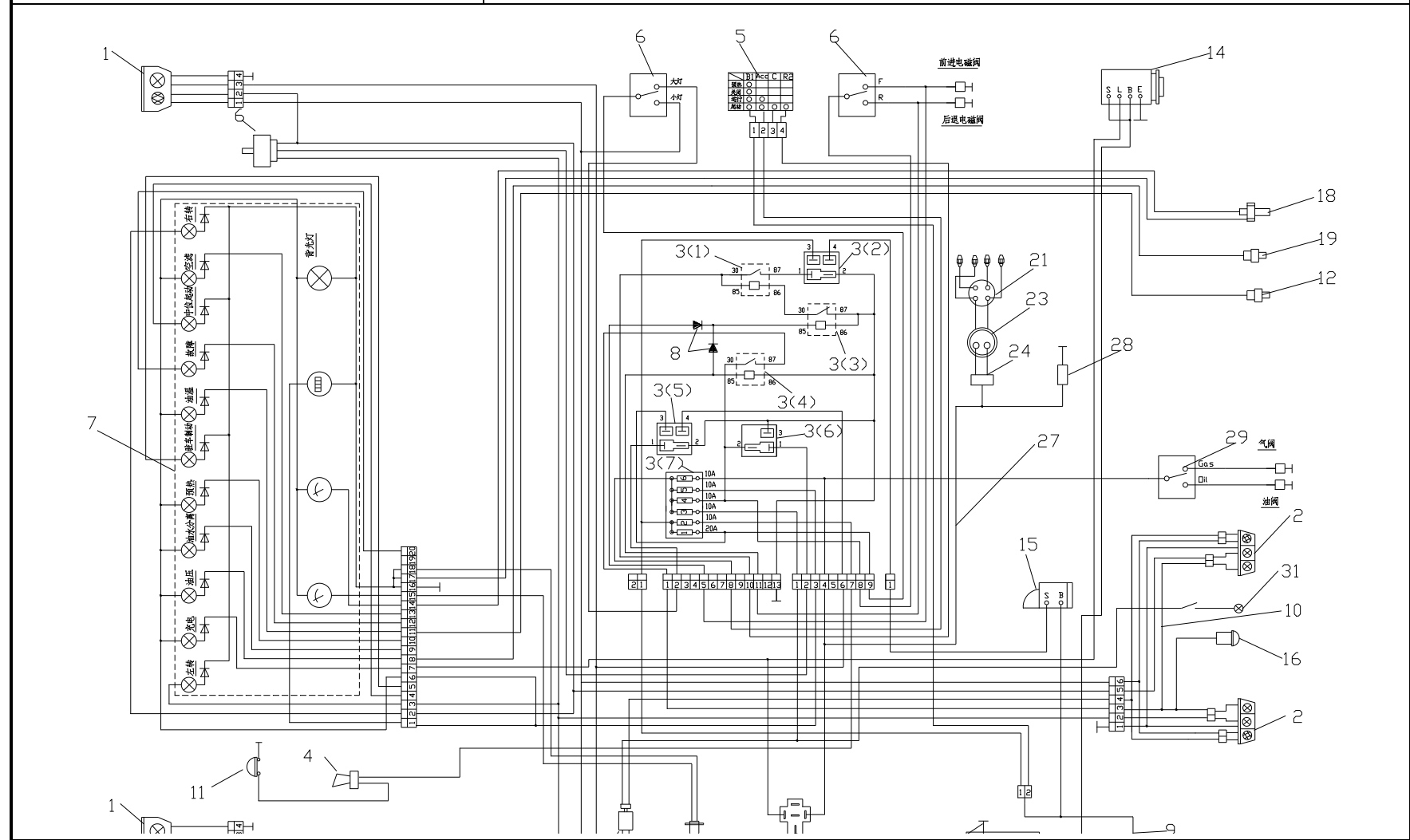
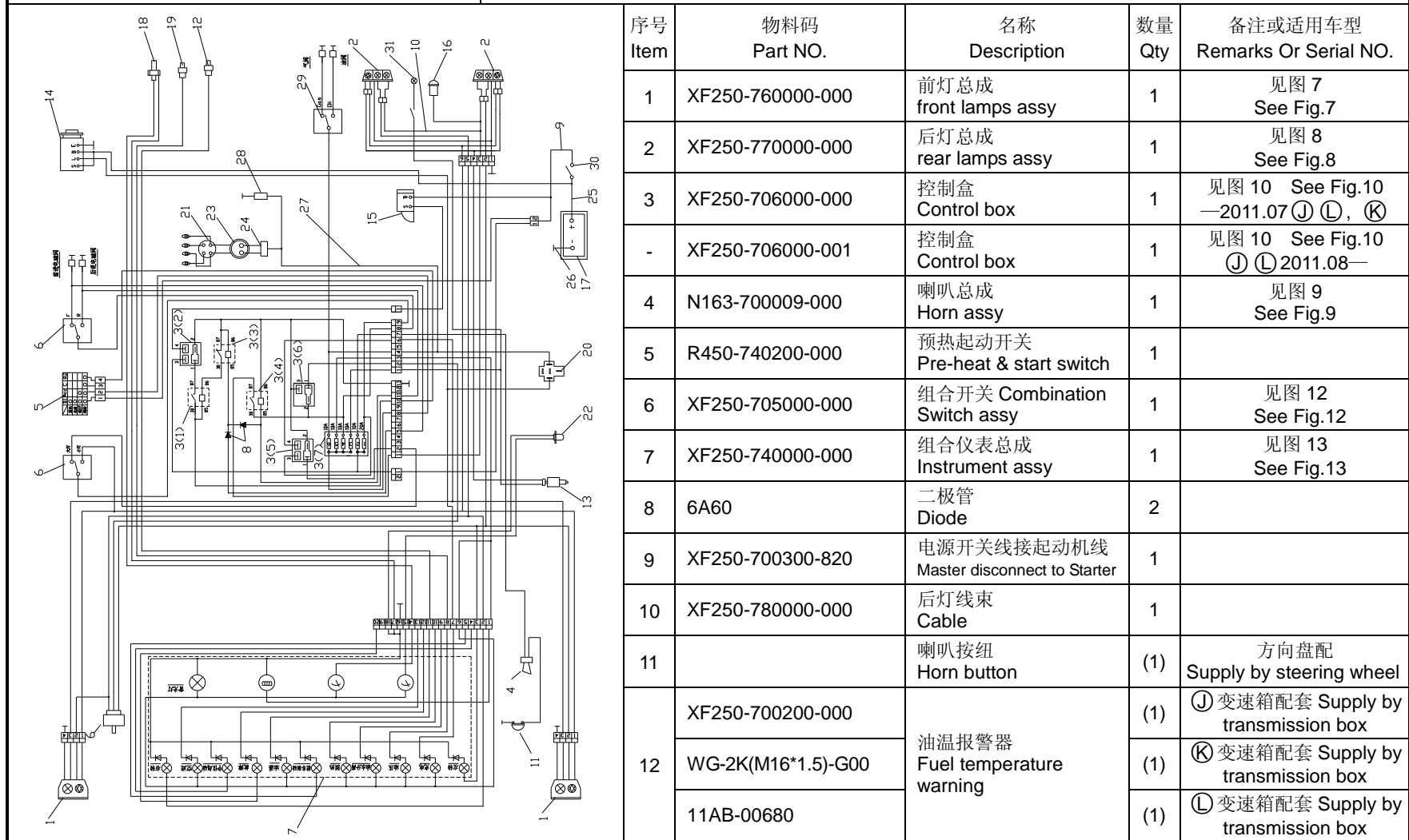

序号 Item	物料码 Part NO.	名称 Description	数量 Qty	备注或适用车型 Remarks Or Serial NO.
1	XF250-760000-000	前灯总成 front lamps assy	1	见图 7 See Fig.7
2	XF250-770000-000	后灯总成 rear lamps assy	1	见图 8 See Fig.8
3	XF250-706000-000	控制盒 Control box	1	见图 10 See Fig.10 —2011.07 Ⓧ Ⓩ, Ⓨ
-	XF250-706000-001	控制盒 Control box	1	见图 10 See Fig.10 Ⓧ Ⓩ 2011.08—
4	N163-700009-000	喇叭总成 Horn assy	1	见图 9 See Fig.9
5	R450-740200-000	预热起动开关 Pre-heat & start switch	1	
6	XF250-705000-000	组合开关 Combination Switch assy	1	见图 12 See Fig.12
7	XF250-740000-000	组合仪表总成 Instrument assy	1	见图 13 See Fig.13
8	6A60	二极管 Diode	2	
9	XF250-700300-820	电源开关线接起动机线 Master disconnect to Starter	1	
10	XF250-780000-000	后灯线束 Cable	1	
11		喇叭按钮 Horn button	(1)	方向盘配 Supply by steering wheel
12	XF250-700200-000	油温报警器 Fuel temperature warning	(1)	Ⓧ 变速箱配套 Supply by transmission box
	WG-2K(M16*1.5)-G00		(1)	Ⓨ 变速箱配套 Supply by transmission box
	11AB-00680		(1)	Ⓩ 变速箱配套 Supply by transmission box

图 18 电气系统 (CE)
Fig.18 Electrical system (CE)

Ⓧ CPQD30/35-XW22F Ⓨ CPQD30/35-XW22B Ⓩ CPQD30/35-XW22M

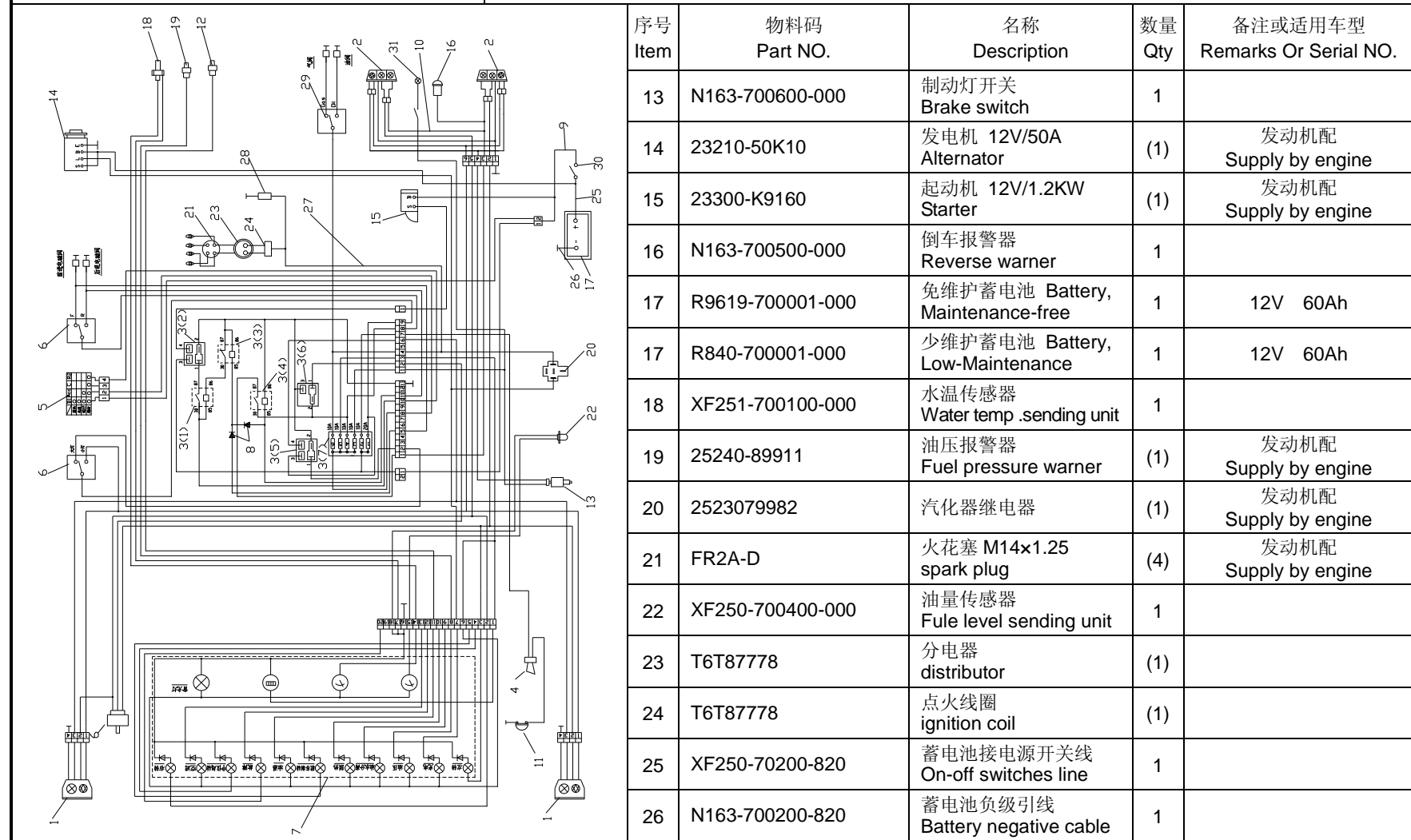

序号 Item	物料码 Part NO.	名称 Description	数量 Qty	备注或适用车型 Remarks Or Serial NO.
13	N163-700600-000	制动灯开关 Brake switch	1	
14	23210-50K10	发电机 12V/50A Alternator	(1)	发动机配 Supply by engine
15	23300-K9160	起动机 12V/1.2KW Starter	(1)	发动机配 Supply by engine
16	N163-700500-000	倒车报警器 Reverse warner	1	
17	R9619-700001-000	免维护蓄电池 Battery, Maintenance-free	1	12V 60Ah
17	R840-700001-000	少维护蓄电池 Battery, Low-Maintenance	1	12V 60Ah
18	XF251-700100-000	水温传感器 Water temp .sending unit	1	
19	25240-89911	油压报警器 Fuel pressure warner	(1)	发动机配 Supply by engine
20	2523079982	汽化器继电器	(1)	发动机配 Supply by engine
21	FR2A-D	火花塞 M14x1.25 spark plug	(4)	发动机配 Supply by engine
22	XF250-700400-000	油量传感器 Fule level sending unit	1	
23	T6T87778	分电器 distributor	(1)	
24	T6T87778	点火线圈 ignition coil	(1)	
25	XF250-70200-820	蓄电池接电源开关线 On-off switches line	1	
26	N163-700200-820	蓄电池负级引线 Battery negative cable	1	

图 18 电气系统 (CE)
Fig.18 Electrical system (CE)

Ⓧ CPQD30/35-XW22F Ⓨ CPQD30/35-XW22B Ⓩ CPQD30/35-XW22M

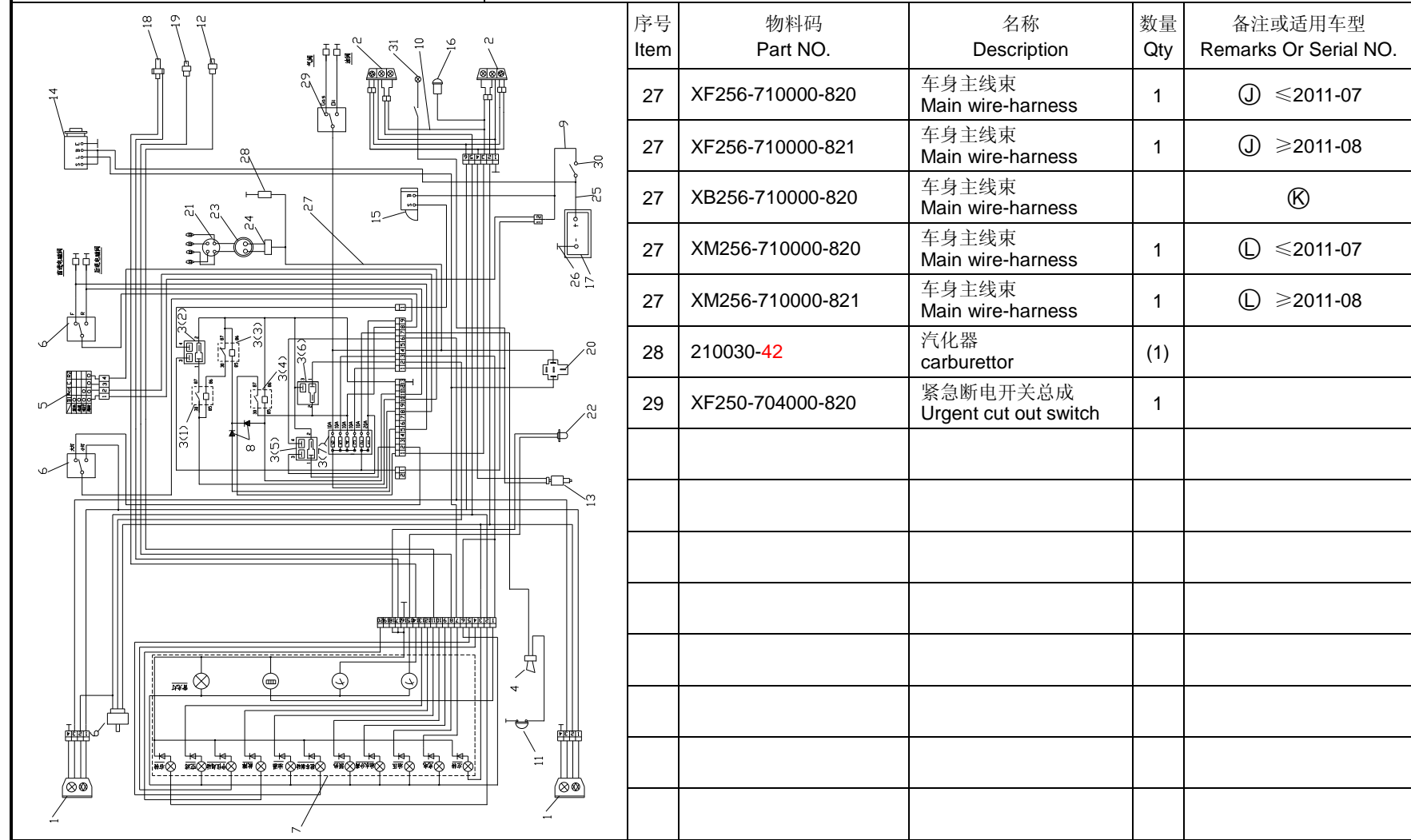

序号 Item	物料码 Part NO.	名称 Description	数量 Qty	备注或适用车型 Remarks Or Serial NO.
27	XF256-710000-820	车身主线束 Main wire-harness	1	Ⓧ ≤2011-07
27	XF256-710000-821	车身主线束 Main wire-harness	1	Ⓧ ≥2011-08
27	XB256-710000-820	车身主线束 Main wire-harness		Ⓨ
27	XM256-710000-820	车身主线束 Main wire-harness	1	Ⓩ ≤2011-07
27	XM256-710000-821	车身主线束 Main wire-harness	1	Ⓩ ≥2011-08
28	210030-42	汽化器 carburettor	(1)	
29	XF250-704000-820	紧急断电开关总成 Urgent cut out switch	1	

