

h2000
SERIES

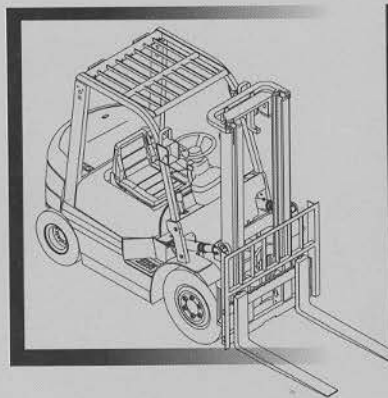

零件目录

parts manual

H2000系列 **2-3.5t**

内燃平衡重式叉车

Balanceweight Type
Forklift Truck With Engine

HELI

安徽合力股份有限公司
ANHUI HELI CO., LTD.



零件目录
parts manual

h2000
SERIES **2-3.5t**

内燃平衡重式叉车

Balanceweight Type
Forklift Truck With Engine



开发处CI工作室
CI STUDIO

开发处CI工作室
CI STUDIO

开发处CI工作室
CI STUDIO

HELI

开发处CI工作室
CI STUDIO

L16-9:2006

本零件目录汇集了H2000系列2-3.5t内燃平衡重式叉车的零部件

查询方法

- 步骤一：在检索目录中找到系统或总成的检索图，其检索图右下角有两个检索标志。其中“P **”为该图所在页次，另一个为该图的检索书签编号；
- 步骤二：翻至所标页次，找到该图；或者，对照书签，找到该图；
- 步骤三：在其图中找出所需零部件，以及它所标注的序号；
- 步骤四：根据这个序号，在其后附表中可以查到系统或零件的详细信息。

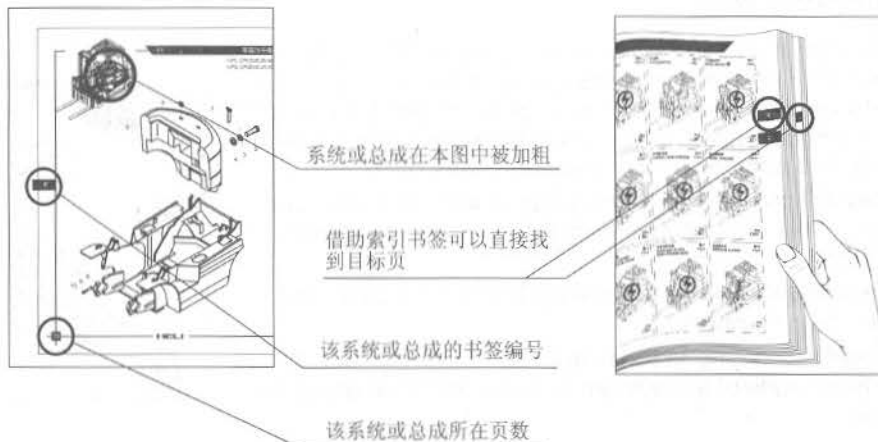

订购零部件时，务请写清叉车的型号、出厂编号、所需零部件的图号及订购数量

在维修时，请使用正规渠道（安徽合力股份有限公司配件分公司）提供的本公司零部件，以确保叉车质量

恕不能将本产品可能进行的零部件改进在本图册中同时修改，您可以从本公司的销售和配件公司获得最新资料

叉车型号说明

C P C D 30-W7

发动机及改型
3吨
液力传动式
C:柴油 Q:汽油
平衡重式叉车

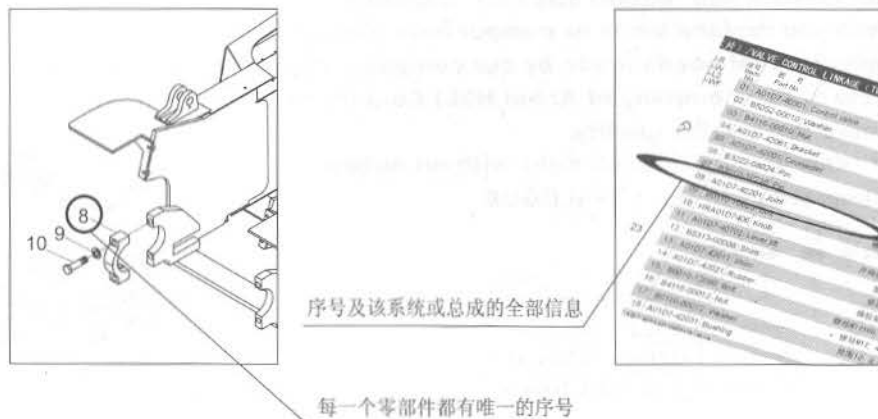

缩写说明	ASS'Y	总成
	R.H.	右
	L.H.	左
	H.P.	高压
	L.P.	低压

THIS PARTS CATALOGUE COVERS PARTS IN THE MOST OF 2 TO 3.5 TON FORKLIFT TRUCKS IN H2000 SERIES

Indexing Way

Step1: Find out the indexing drawing for the system or assembly required from the indexing contents and see two marks at lower right corner of the drawing: one is "p**" denoting the page of the detail drawing in this CATALOGUE and another denoting section mark code.

Step2: According to above page or section mark code, find out the detail drawing for the system or assembly required.

Step3: From the detail drawing, find out the parts and their item numbers.

Step4: According to these item numbers, find out details of these parts of the system or assembly from attached table.

When ordering the parts or components, please indicate the model and series number of the your forklift truck, the drawing number of parts or components you require and their quantity.

When you replace parts or components, please apply the real goods made by our company (Spare Parts Sub-company of Anhui HELI Co.,Ltd) to ensure the truck's quality.

We reserve modification right without notice

Designations in the CATALOGUE

C P C D 30-W7

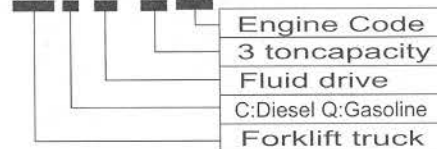

Abbreviations in the CATALOGUE

ASS'Y	assembly	H.P.	High pressure
R.H	right hand	L.P.	low pressure
L.H	left hand		

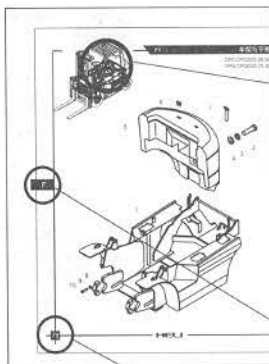

This system or assembly is within the coarse solid line circle.

With a aid of the section mark code, the page required may be found

This section mark code denotes the position of the system or assembly drawing in this CATALOGUE

This page code denotes this system or assembly drawing shows on the page.

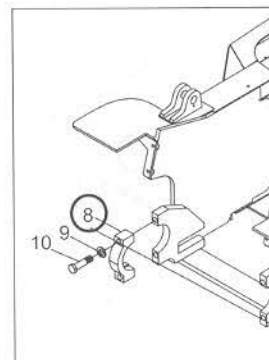
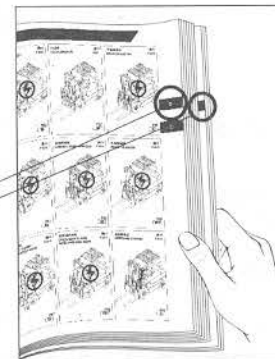

According to these item numbers, find out details of these parts or the system from attached table.

Every part or componet in the drawing is expressed with only item number

VALVE CONTROL LINKAGE	
ITEM NO.	ITEM NAME
10	10-1042107406 Lever
11	11-1042107406 Nut
12	12-80113-00010 Lever
13	13-80113-00010 Shim
14	14-10117-42011 Pin
15	15-10117-42011 Pin
16	16-84115-20002 Pin
17	17-80113-00012 Nut
18	18-10117-42011 Pin
19	19-10117-42011 Pin

本零件目录汇集了H2000系列2-3.5t内燃平衡重式叉车的零部件

具体车型与发动机的对应关系:

CPQ, CPQD20, 25-R6配H20KA4GR00发动机	CPQ, CPQD30-R6配H25KA4GR00发动机
CPQ, CPQD20H, 25H-R11配H25KA4GR00发动机	CPQ, CPQD30-R12配H20KA4GR00发动机
CPC, CPCD20, 25, 30-X6配新昌A490BPG发动机	CPC, CPCD20, 25, 30-W8配4JG2PE-01发动机
CPC, CPCD20, 25, 30-W7配C240PKJ-17发动机	CPC, CPCD20, 25, 30, 35-HJ配江铃HJ493发动机
CPC, CPCD20, 25, 30, 35-Xs1配4D95LE-3发动机	CPC, CPCD20, 25, 30, 35-D配大柴CA498-12带泵发动机
CPC, CPCD20, 25, 30-W9配C240PKJ-20发动机	CPQ, CPQD35-R4配H20KA4GR00发动机
CPQ, CPQD35-R3配H25KA4GR00发动机	CPC, CPCD35-W5配C240PKJ-17发动机
CPC, CPCD35-W4配4JG2PE-01发动机	CPC, CPCD35-X2配新昌A490BPG发动机
CPC, CPCD35-W6配C240PKJ-20发动机	CPQ, CPQD20, 25, 30, 35-ZJ3配HW491GPE电喷带泵汽油机
CPQ, CPQD20, 25, 30, 35-ZJ2配HW491GP带泵汽油机	

注:EX-A表示向美国和加拿大出口而制造的专用零件

EX-B表示面向一般市场而制造的专用零件

The following trucks are provided with corresponding engine

CPQ, CPQD20, 25-R6/H20KA4GR00 engine	CPQ, CPQD30-R6/H25KA4GR00 engine
CPQ, CPQD20H, 25H-R11/H25KA4GR00 engine	CPQ, CPQD30-R12/H20KA4GR00 engine
CPC, CPCD20, 25, 30-X6/A490GAP engine	CPC, CPCD20, 25, 30-W8/4JG2PE-01 engine
CPC, CPCD20, 25, 30-W7/C240PKJ-17 engine	CPC, CPCD20, 25, 30, 35-HJ/HJ493 engine
CPC, CPCD20, 25, 30, 35-Xs1/4D95LE-3 engine	CPC, CPCD20, 25, 30, 35-D/CA498-12 engine
CPC, CPCD20, 25, 30-W9/C240PKJ-20 engine	CPQ, CPQD35-R4/H20KA engine
CPQ, CPQD35-R3/H25KA engine	CPC, CPCD35-W5/C240PKJ-17 engine
CPC, CPCD35-W4/4JG2PE-01 engine	CPC, CPCD35-X2/A490GAP engine
CPC, CPCD35-W6/C240PKJ-20 engine	CPQ, CPQD20, 25, 30, 35-ZJ3/HW491GPE engine
CPQ, CPQD20, 25, 30, 35-ZJ2/HW491GP engine	

NOTE: EX-A:Special parts made for the forklift trucks exported to US and Canada

EX-B:Parts made for common forklift trucks markets

具体车型与出口美国市场车型的对应关系:

CPQD20, 25-R6配H20KA4GR00发动机	FG40, 50
CPQD30-R6配H25KA4GR00发动机	FG60
CPQD20H, 25H-R11配H25KA4GR00发动机	FG40, 50
CPQD30-R12配H20KA4GR00发动机	FG60
CPCD20, 25, 30-W7配C240PKJ-17发动机	FD40, 50, 60
CPCD20, 25, 30-W8配4JG2PE-01发动机	FD40, 50, 60
CPCD20, 25, 30, 35-Xs1配4D95LE-3发动机	FD40, 50, 60, 70
CPCD20, 25, 30-W9配C240PKJ-20发动机	FD40, 50, 60
CPQD35-R3配H25KA4GR00发动机	FG70
CPQD35-R4配H20KA4GR00发动机	FG70
CPCD35-W4配4JG2PE-01发动机	FD70
CPCD35-W5配C240PKJ-17发动机	FD70
CPCD35-W6配C240PKJ-20发动机	FD70

The following trucks are provided with corresponding between exported to US and correct types

CPQ, CPQD20, 25-R6/H20KA4GR00 engine	FG40, 50
CPQ, CPQD30-R6/H25KA4GR00 engine	FG60
CPQ, CPQD20H, 25H-R11/H25KA4GR00 engine	FG40, 50
CPQ, CPQD30-R12/H20KA4GR00 engine	FG60
CPC, CPCD20, 25, 30-W7/C240PKJ-17 engine	FD40, 50, 60
CPC, CPCD20, 25, 30-W8/4JG2PE-01 engine	FD40, 50, 60
CPC, CPCD20, 25, 30, 35-Xs1/4D95LE-3 engine	FD40, 50, 60, 70
CPC, CPCD20, 25, 30-W9/C240PKJ-20 engine	FD40, 50, 60
CPQ, CPQD35-R3/H25KA engine	FG70
CPQ, CPQD35-R4/H20KA engine	FG70
CPC, CPCD35-W4/4JG2PE-01 engine	FD70
CPC, CPCD35-W5/C240PKJ-17 engine	FD70
CPC, CPCD35-W6/C240PKJ-20 engine	Fd70

目录 INDEX

发动机(汽油机)
ENGIEN (GASOLINE)



图1
FIG1

P1
A1

发动机(柴油机)
ENGIEN (DIESEL)

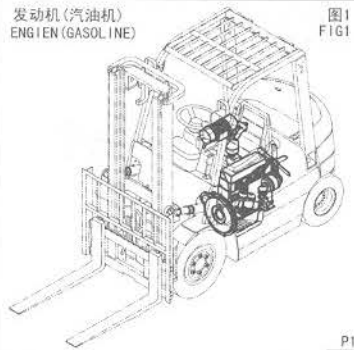

图2
FIG2

P2
A2

发动机(柴油机)
ENGIEN (DIESEL)

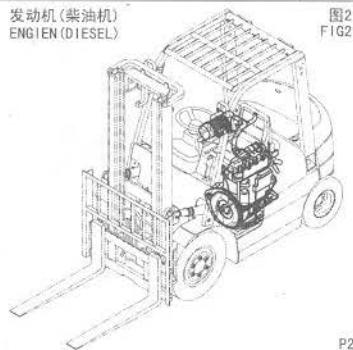

图3
FIG3

P3
A3

发动机(柴油机)
ENGIEN (DIESEL)

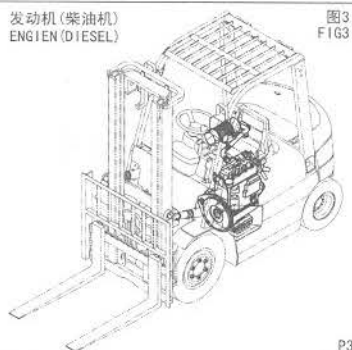

图4
FIG4

P4
A4

发动机(汽油机)
ENGIEN (GASOLINE)

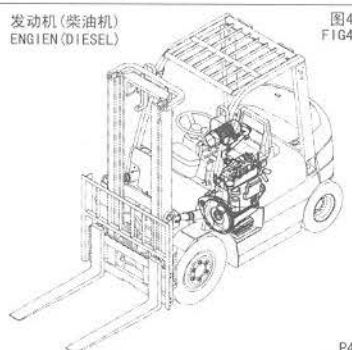

图5
FIG5

P5
A5

发动机(柴油机)
ENGIEN (DIESEL)

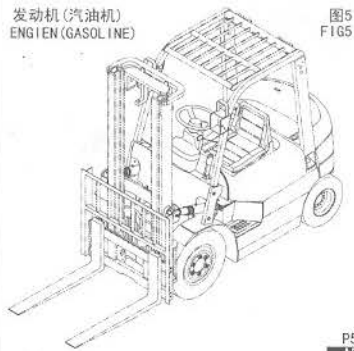

图6
FIG6

P6
A6

空滤器安装(柴油机)
AIR CLEANER ASS'Y
(DIESEL)

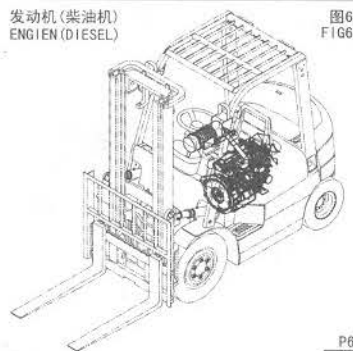

图7
FIG7

P7
A7

空滤器安装(汽油机)
AIR CLEANER ASS'Y
(GASOLINE)

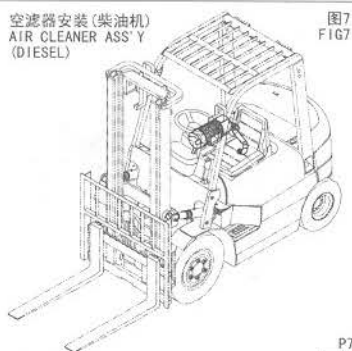

图8
FIG8

P8
A8

空滤器安装(柴油机)
AIR CLEANER ASS'Y
(DIESEL)

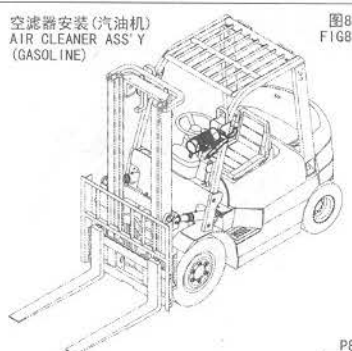

图9
FIG9

P9
A9

空滤器安装(汽油机)
AIR CLEANER ASS'Y
(GASOLINE)

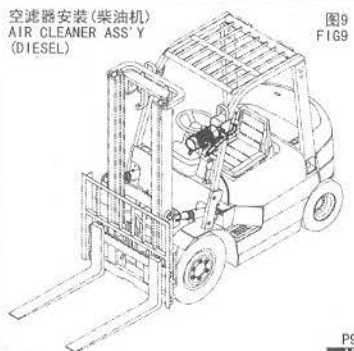

图10
FIG10

P10
A10

空滤器安装(柴油机)
AIR CLEANER ASS'Y
(DIESEL)

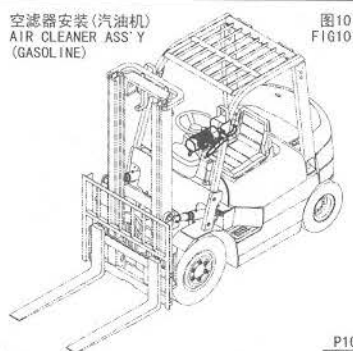

图11
FIG11

P11
A11

空滤器安装(柴油机)
AIR CLEANER ASS'Y
(DIESEL)

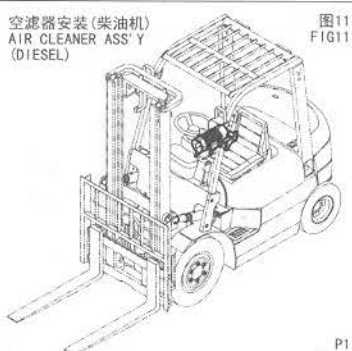

图12
FIG12

P12
A12

目录 INDEX

空滤器安装(柴油机)
AIR CLEANER ASS'Y
(DIESEL)

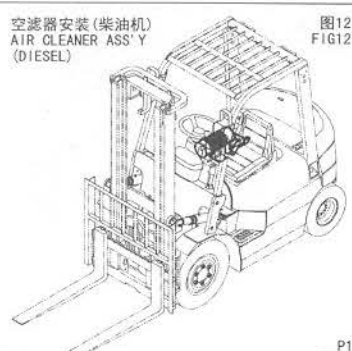

图13
FIG13

P13
A13

冷却系统
COOLING SYSTEM

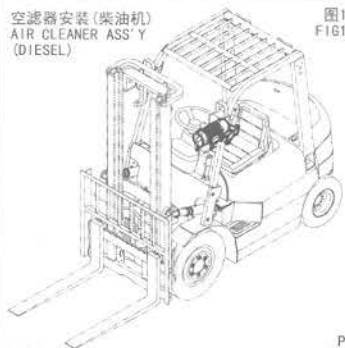

图14
FIG14

P14
A14

冷却系统
COOLING SYSTEM

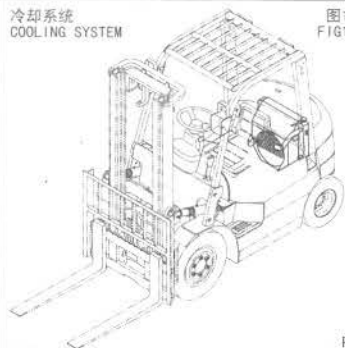

图15
FIG15

P15
A15

冷却系统(柴油机)
COOLING SYSTEM
(DIESEL)

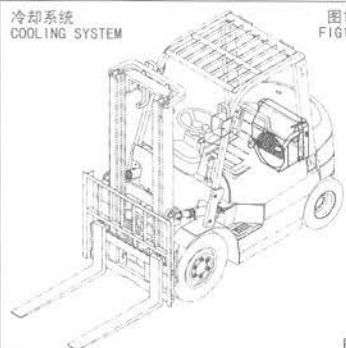

图16
FIG16

P16
A16

冷却系统(柴油机)
COOLING SYSTEM
(DIESEL)

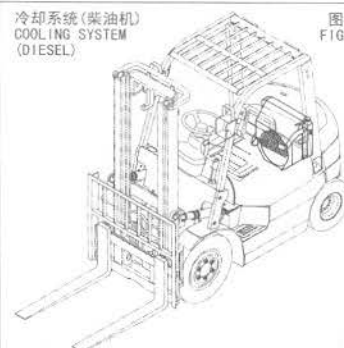

图17
FIG17

P17
A17

冷却系统(柴油机)
COOLING SYSTEM
(DIESEL)

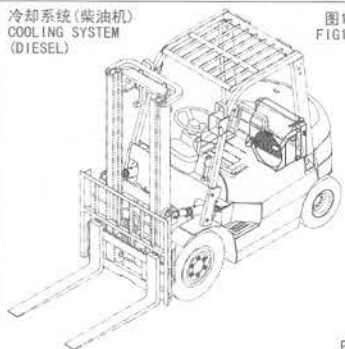

图18
FIG18

P18
A18

冷却系统(柴油机)
COOLING SYSTEM
(DIESEL)

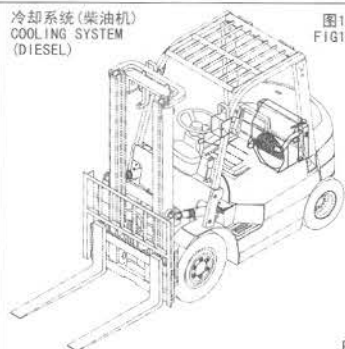

图19
FIG19

P19
A19

冷却系统(柴油机)
COOLING SYSTEM
(DIESEL)

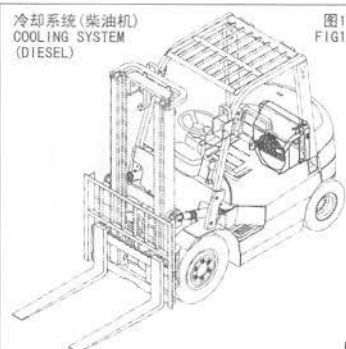

图20
FIG20

P20
A20

燃油系统
FUEL SYSTEM

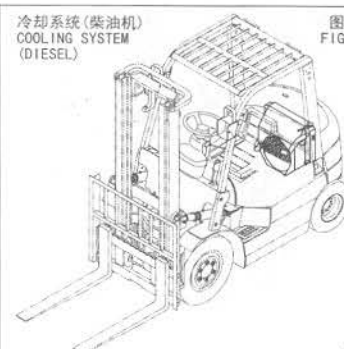

图21
FIG21

P21
A21

燃油系统
FUEL SYSTEM

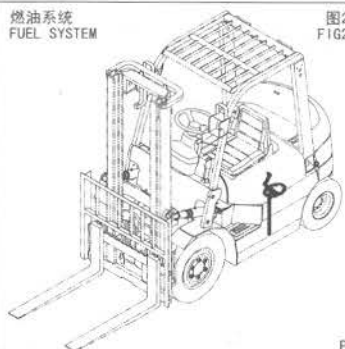

图22
FIG22

P22
A22

燃油系统
FUEL SYSTEM

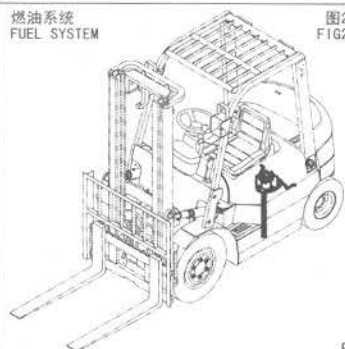

图23
FIG23

P23
A23

燃油系统
FUEL SYSTEM

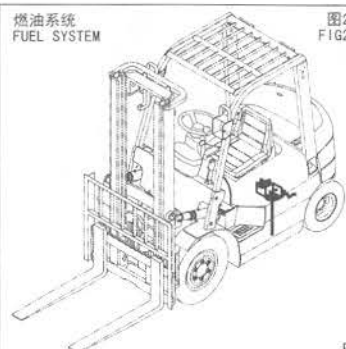

图24
FIG24

P24
A24

目录 INDEX

燃油系统
FUEL SYSTEM

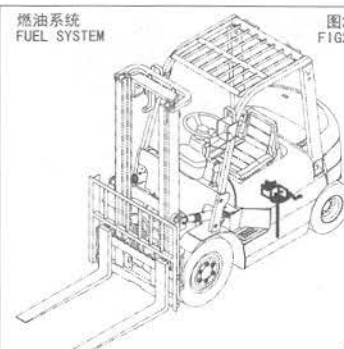

图25
FIG25

P25
A25

燃油系统
FUEL SYSTEM

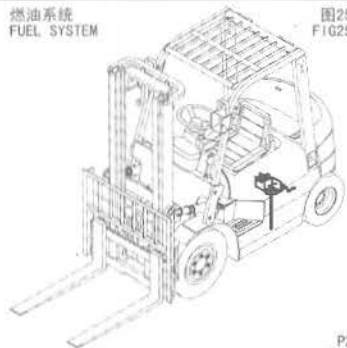

图26
FIG26

P26
A26

燃油系统
FUEL SYSTEM

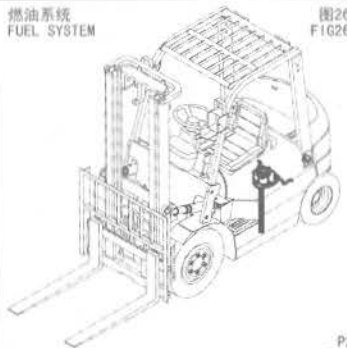

图27
FIG27

P27
A27

燃油系统
FUEL SYSTEM

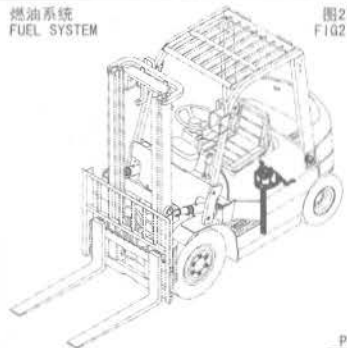

图28
FIG28

P28
A28

燃油系统
FUEL SYSTEM

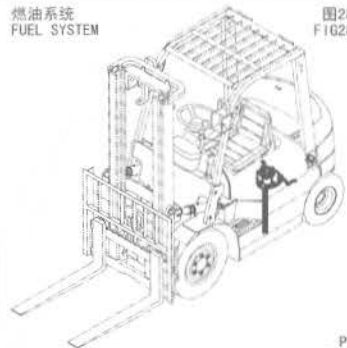

图29
FIG29

P29
A29

排气系统
EXHAUST SYSTEM

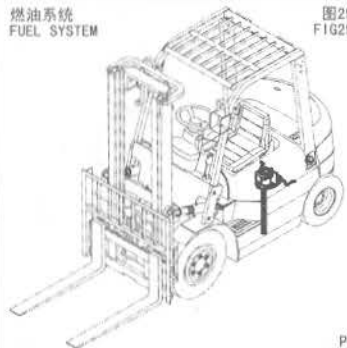

图30
FIG30

P30
A30

排气系统
EXHAUST SYSTEM

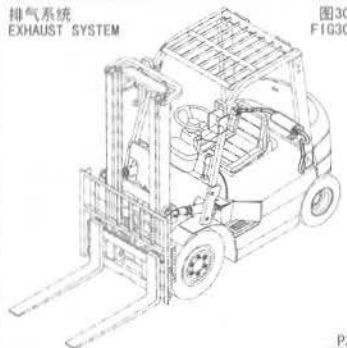

图31
FIG31

P31
A31

排气系统
EXHAUST SYSTEM

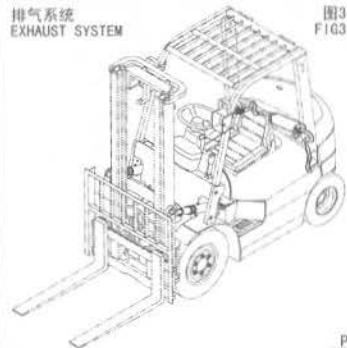

图32
FIG32

P32
A32

排气系统
EXHAUST SYSTEM

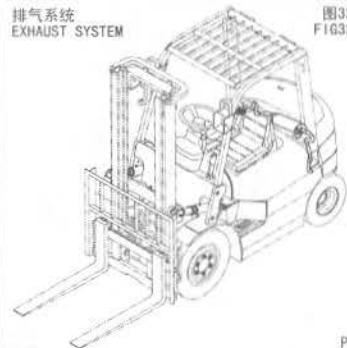

图33
FIG33

P33
A33

排气系统
EXHAUST SYSTEM

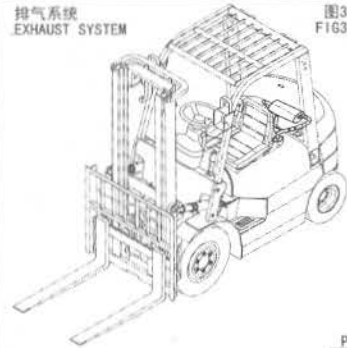

图34
FIG34

P34
A34

排气系统
EXHAUST SYSTEM

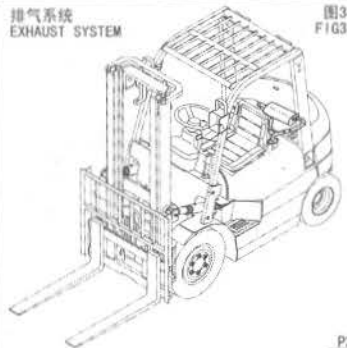

图35
FIG35

P35
A35

排气系统
EXHAUST SYSTEM

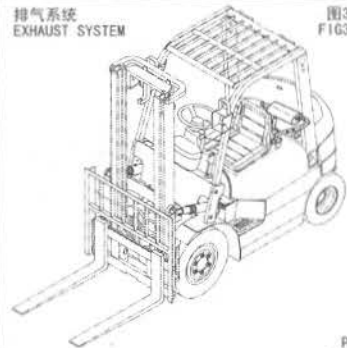

图36
FIG36

P36
A36

目录 INDEX

排气系统
EXHAUST SYSTEM

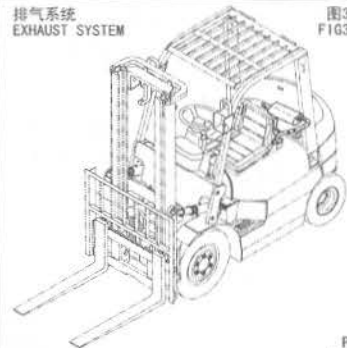

图37
FIG37

P37
A37

排气系统
EXHAUST SYSTEM

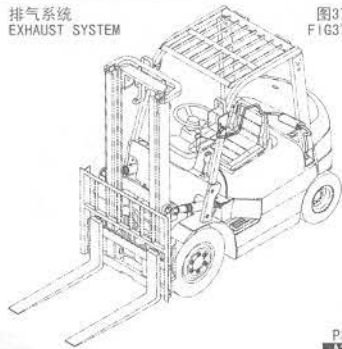

图38
FIG38

P38
A38

排气系统
EXHAUST SYSTEM

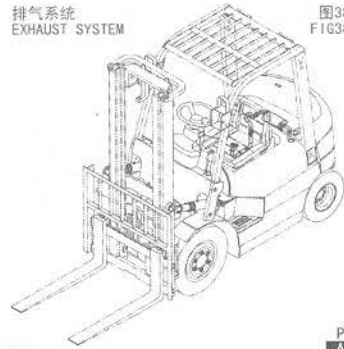

图39
FIG39

P39
A39

排气系统
EXHAUST SYSTEM

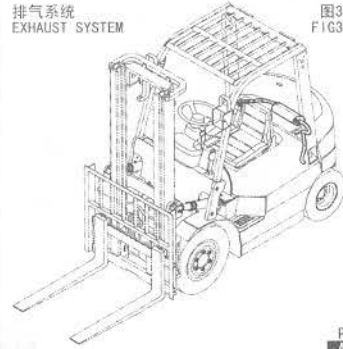

图40
FIG40

P40
A40

电气系统
ELECTRIC SYSTEM

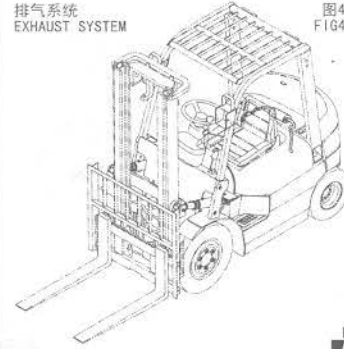

图41
FIG41

P41
B1

电气系统
ELECTRIC SYSTEM

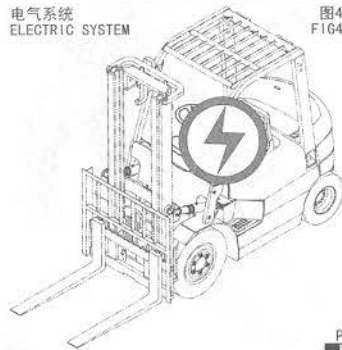

图42
FIG42

P43
B2

电气系统
ELECTRIC SYSTEM

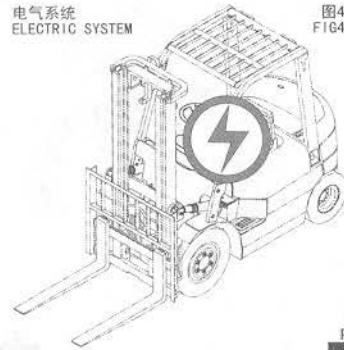

图43
FIG43

P44
B3

电气系统
ELECTRIC SYSTEM

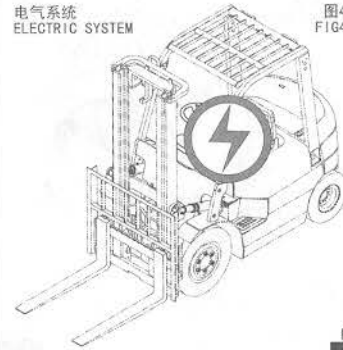

图44
FIG44

P45
B4

电气系统
ELECTRIC SYSTEM

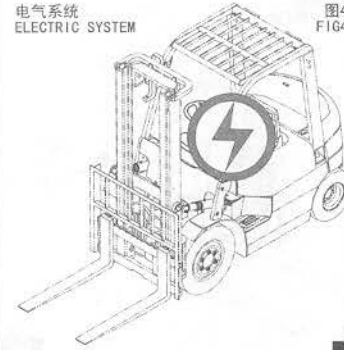

图45
FIG45

P47
B5

电气系统
ELECTRIC SYSTEM

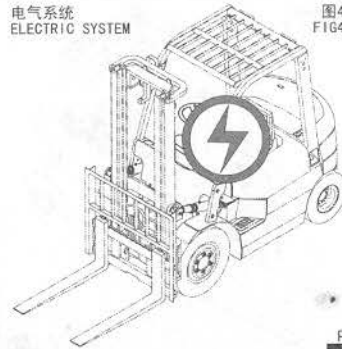

图46
FIG46

P49
B6

电气系统
ELECTRIC SYSTEM

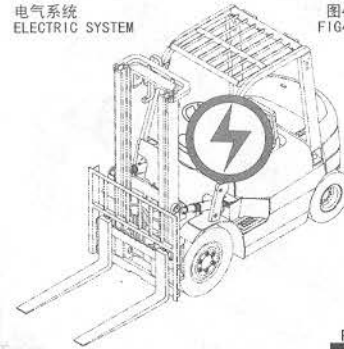

图47
FIG47

P51
B7

电气系统
ELECTRIC SYSTEM

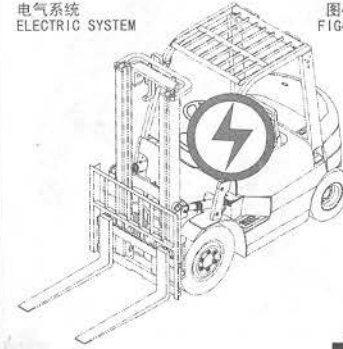

图48
FIG48

P53
B8

A
B

电气系统
ELECTRIC SYSTEM

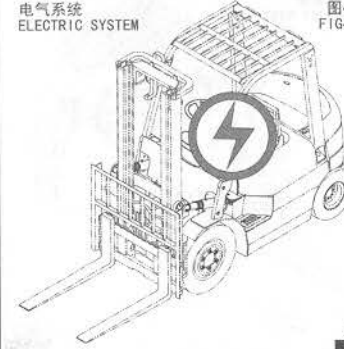
图49
FIG49

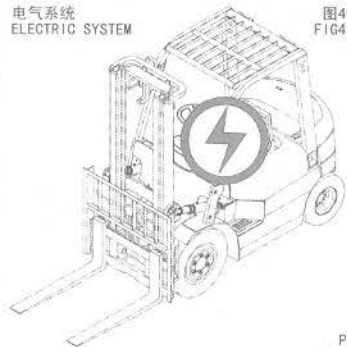

P55
B9

H2000型组合仪表总成
COMBINATION M/T,
H2000 TYPE

图50
FIG50

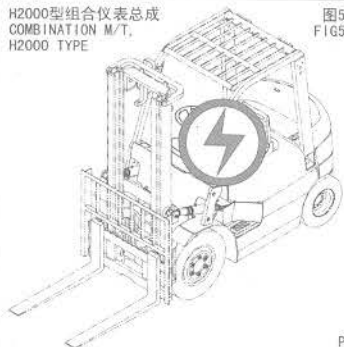

P57
B10

H2001型组合仪表总成
COMBINATION M/T,
H2001 TYPE

图51
FIG51

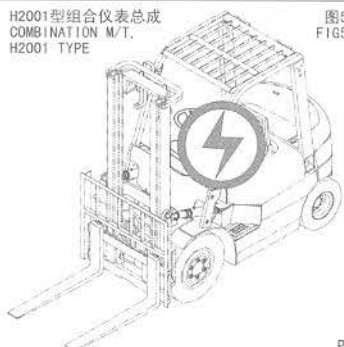

P58
B11

ZB908型组合仪表
COMBINATION M/T,
ZB908 TYPE

图52
FIG52

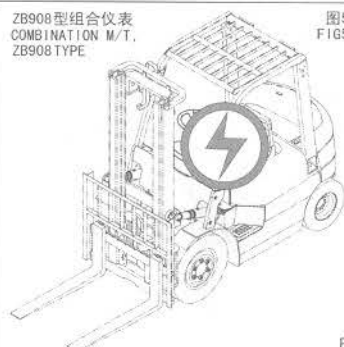

P59
B12

电器元件安装
ELECTRIC ELEMENT
MOUNT

图53
FIG53

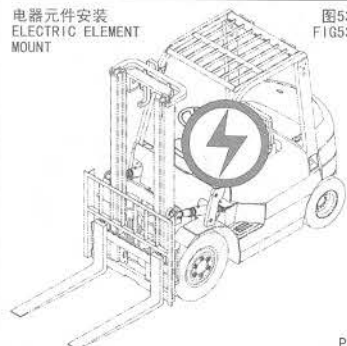

P60
B13

电器元件安装
ELECTRIC ELEMENT MOUNT

图54
FIG54

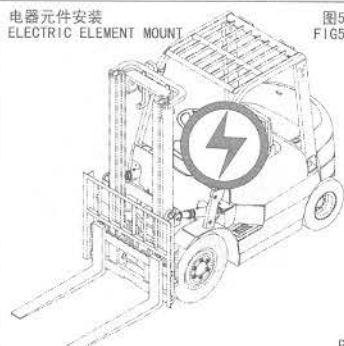

P61
B14

电器元件安装
ELECTRIC ELEMENT MOUNT

图55
FIG55

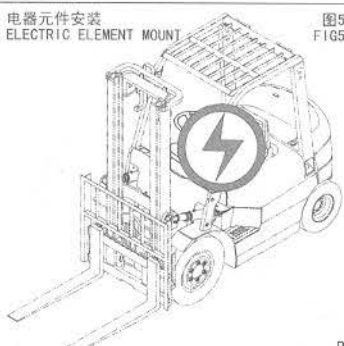

P62
B15

电器元件安装
ELECTRIC ELEMENT MOUNT

图56
FIG56

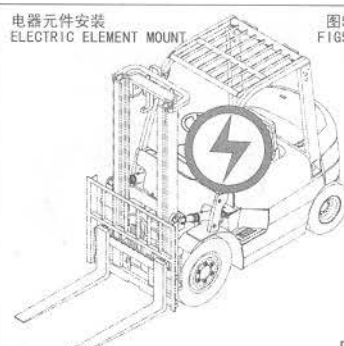

P63
B16

电器元件安装
ELECTRIC ELEMENT MOUNT

图57
FIG57

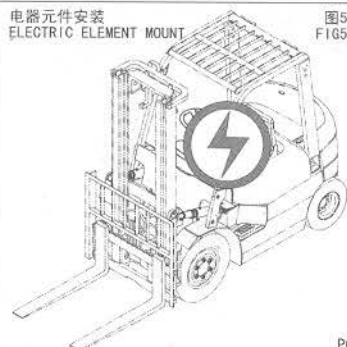

P64
B17

传动装置安装(液力式)
DRIVE UNIT MOUNT
(TOR-CON TYPE)

图58
FIG58

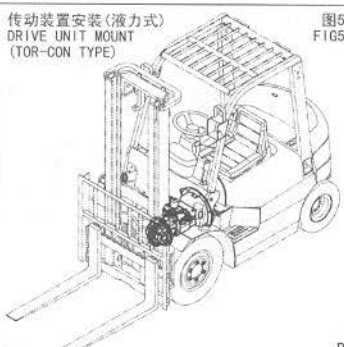

P65
C1

传动装置安装(液力式)
DRIVE UNIT MOUNT
(TOR-CON TYPE)

图59
FIG59

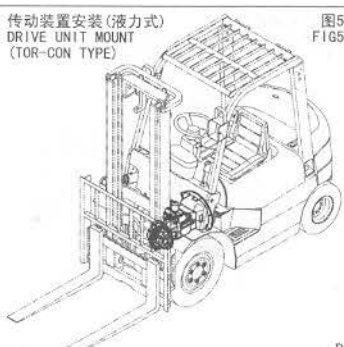

P66
C2

传动装置(液力式)
DRIVE UNIT
(TOR-CON TYPE)

图60
FIG60

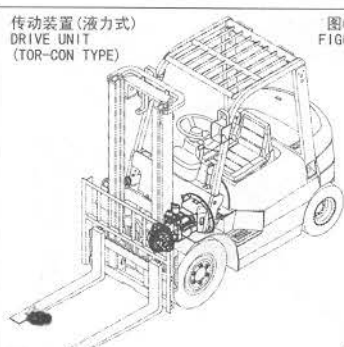

P67
C3

目录 INDEX

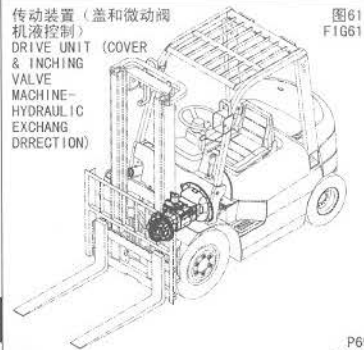

传动装置 (盖和微动阀)
机液控制
DRIVE UNIT (COVER
& INCHING
VALVE
MACHINE-
HYDRAULIC
EXCHANG
DRRECTION)

图61
FIG61

P69
C4

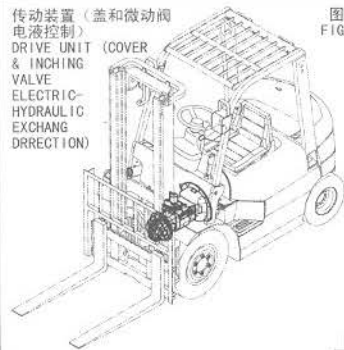

传动装置 (盖和微动阀)
电液控制
DRIVE UNIT (COVER
& INCHING
VALVE
ELECTRIC-
HYDRAULIC
EXCHANG
DRRECTION)

图62
FIG62

P71
C5

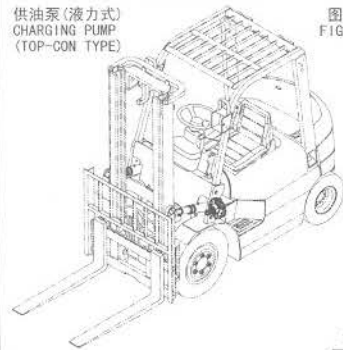

供油泵 (液力式)
CHARGING PUMP
(TOP-CON TYPE)

图63
FIG63

P72
C6

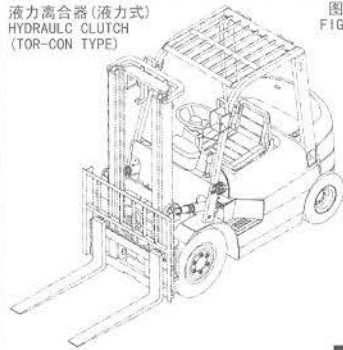

液力离合器 (液力式)
HYDRAULIC CLUTCH
(TOR-CON TYPE)

图64
FIG64

P73
C7

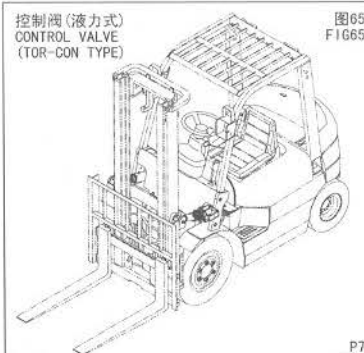

控制阀 (液力式)
CONTROL VALVE
(TOR-CON TYPE)

图65
FIG65

P74
C8

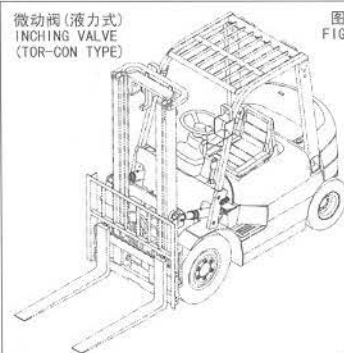

微动阀 (液力式)
INCHING VALVE
(TOR-CON TYPE)

图66
FIG66

P75
C9

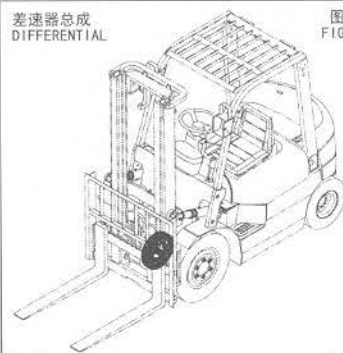

差速器总成
DIFFERENTIAL

图67
FIG67

P76
C10



传动装置安装 (机械式)
DRIVE UNIT MOUNT
(CLUTCH TYPE)

图68
FIG68

P77
C11

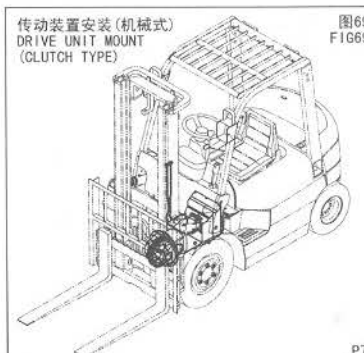

传动装置安装 (机械式)
DRIVE UNIT MOUNT
(CLUTCH TYPE)

图69
FIG69

P79
C12

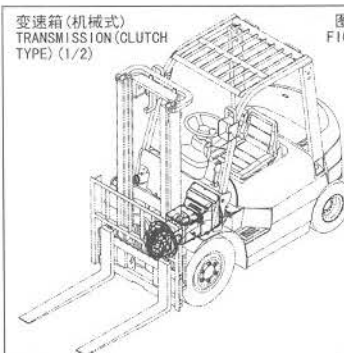

变速箱 (机械式)
TRANSMISSION (CLUTCH
TYPE) (1/2)

图70
FIG70

P80
C13

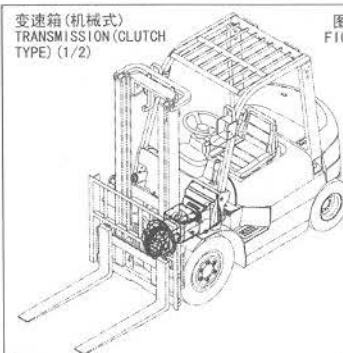

变速箱 (机械式)
TRANSMISSION (CLUTCH
TYPE) (2/2)

图71
FIG71

P82
C14

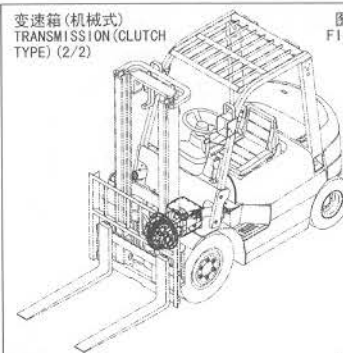

变速箱 (机械式)
TRANSMISSION (CLUTCH
TYPE) (2/2)

图72
FIG72

P84
C15

目录 INDEX

传动装置安装 (机械式)
DRIVE UNIT MOUNT
(CLUTCH TYPE)



图73
FIG73

P86
C16

变速箱 (机械式)
TRANSMISSION (CLUTCH
TYPE) (1/2)

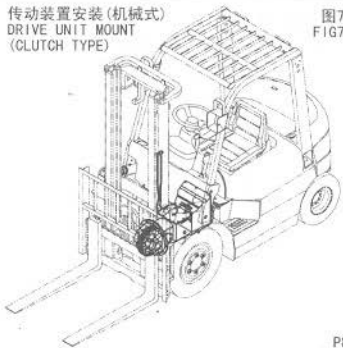

图74
FIG74

P88
C17

变速箱 (机械式)
TRANSMISSION (CLUTCH
TYPE) (2/2)

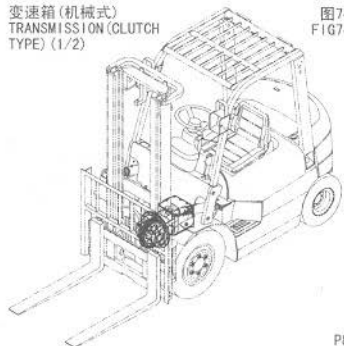

图75
FIG75

P90
C18

驱动桥
DRIVE AXLE

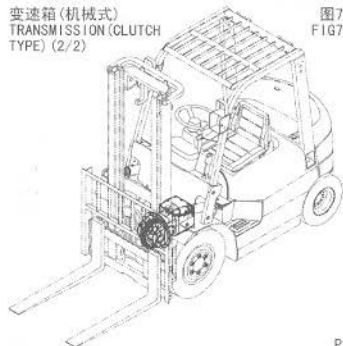

图76
FIG76

P93
C19

驱动轮 (2t. 2.5t单)
DRIVE WHEEL
(SINGLE TIRE)

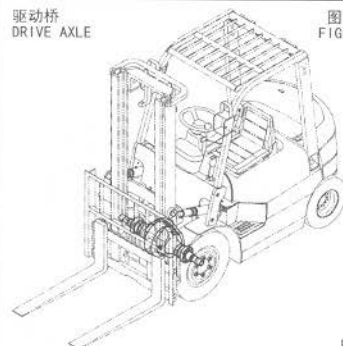

图77
FIG77

P95
C20

驱动轮 (2t. 2.5t双胎)
DRIVE WHEEL
(DOUBLE TIRE)

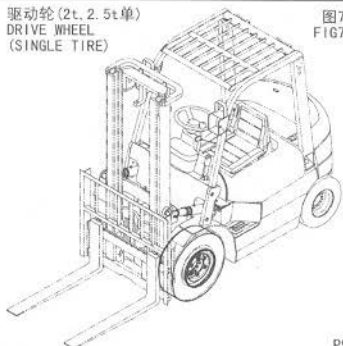

图78
FIG78

P96
C21

驱动轮 (3t. 3.5t单胎)
DRIVE WHEEL
(SINGLE TIRE)

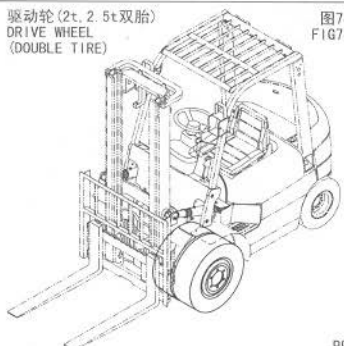

图79
FIG79

P97
C22

驱动轮 (3t. 3.5t双胎)
DRIVE WHEEL
(DOUBLE TIRE)

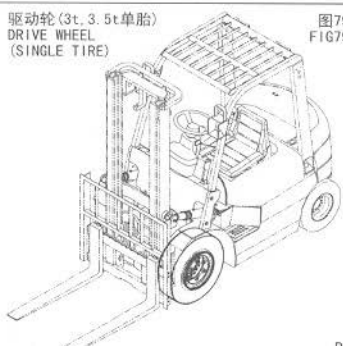

图80
FIG80

P98
C23

轮式制动器 (2t. 2.5t)
WHEEL BRAKE

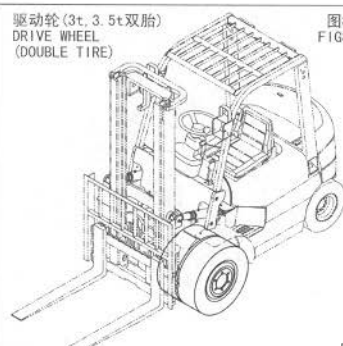

图81
FIG81

P99
C24

轮式制动器 (3t. 3.5t)
WHEEL BRAKE

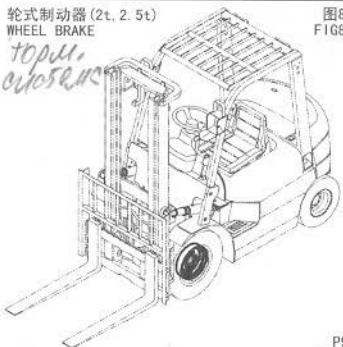

图82
FIG82

P101
C25

变速箱变速操纵 (液力式)
TRANSMISSION CONTROL
LINKAGE (TOR-CON
TYPE)

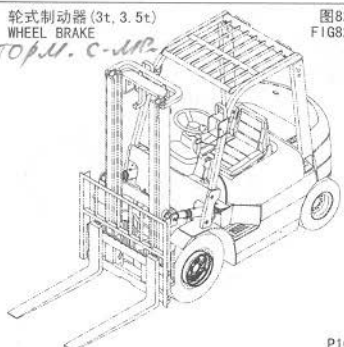

图83
FIG83

P103
C26

转向系统
STEERING SYSTEM

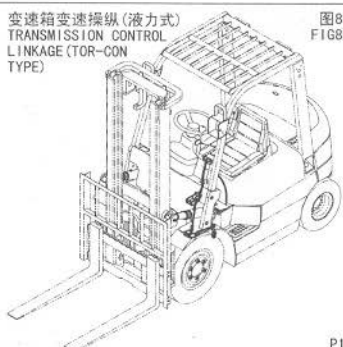

图84
FIG84

P104
D1

目录 INDEX

转向桥
STEERING AXLE

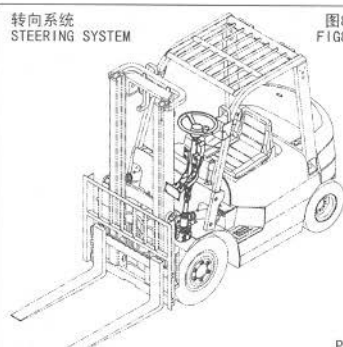

图85
FIG85

P106
D2

转向轮
DRIVE WHEEL

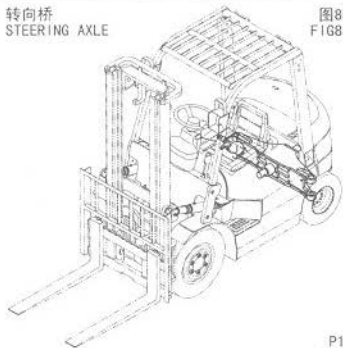

图86
FIG86

P108
D3

转向油缸
DRIVE CYLINDER

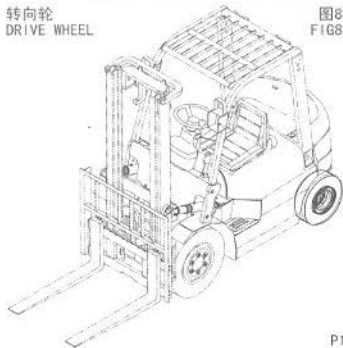

图87
FIG87

P109
D4

油门操纵(液力式)
ACCELERATOR PEDAL
(TOR-CON TYPE)

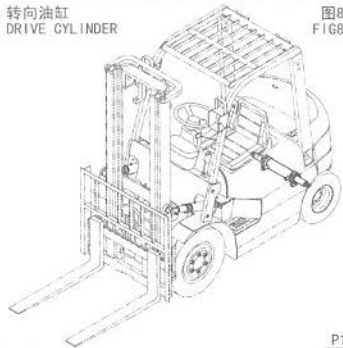

图88
FIG88

P110
E1

油门操纵(机械式)
ACCELERATOR PEDAL
(DIESEL-CLUTCH
TYPE)

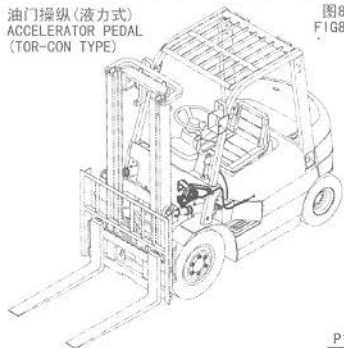

图89
FIG89

P111
E2

油门操纵
ACCELERATOR PEDAL

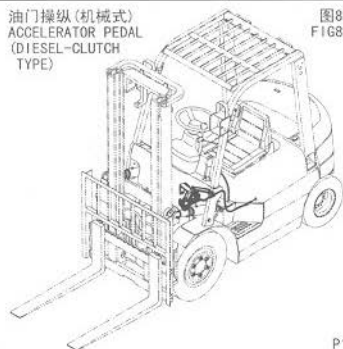

图90
FIG90

P112
E3

油门操纵
ACCELERATOR PEDAL

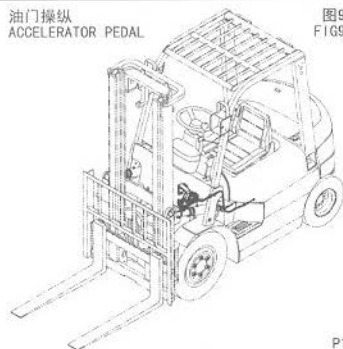

图91
FIG91

P113
E4

油门操纵
ACCELERATOR PEDAL

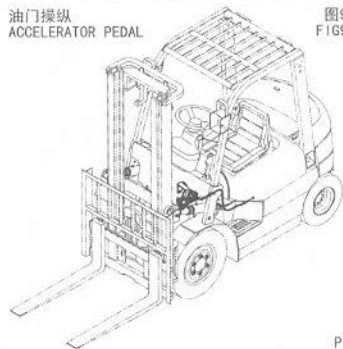

图92
FIG92

P114
E5

油门操纵
ACCELERATOR PEDAL

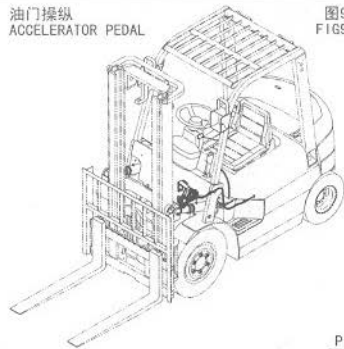

图93
FIG93

P115
E6

油门操纵
ACCELERATOR PEDAL

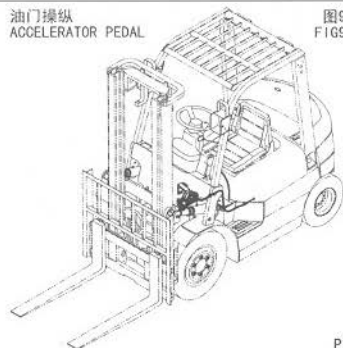

图94
FIG94

P116
E7

行车制动与微动操纵
(液力式)
BRAKE & INCHING
CONTROL (TOR-
CON TYPE)

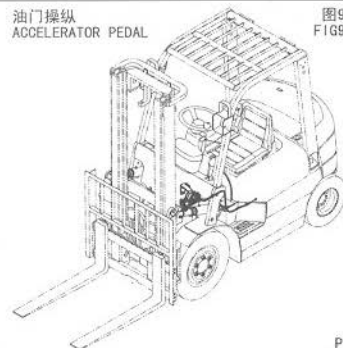

图95
FIG95

P117
E8

行车制动与离合操纵
(机械式)
BRAKE & CLUTCH
CONTROL (CL-
UTCH TYPE)

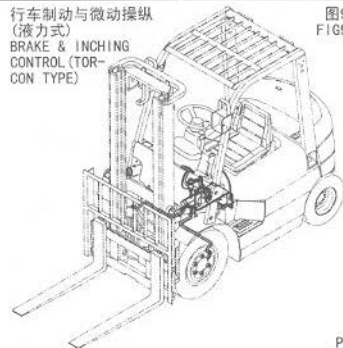

图96
FIG96

P119
E9

目录 INDEX

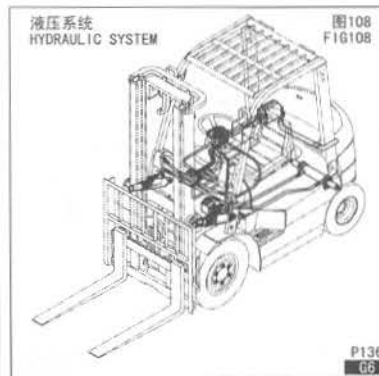
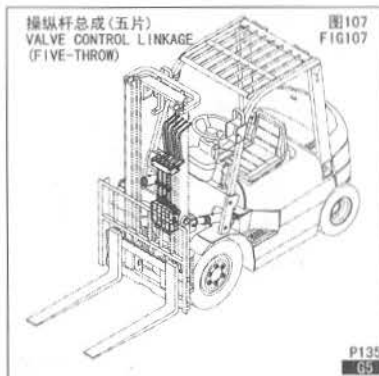
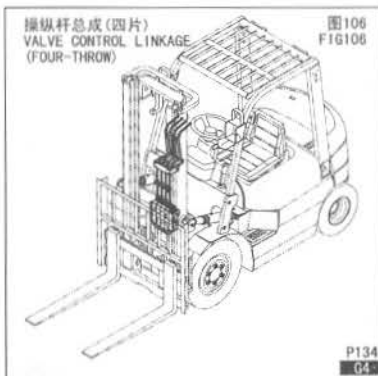
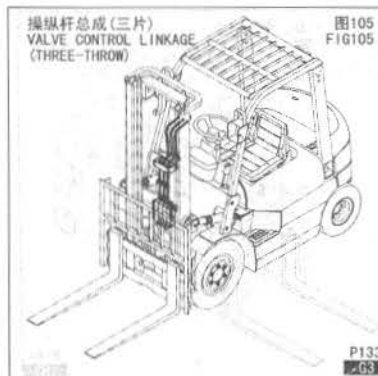
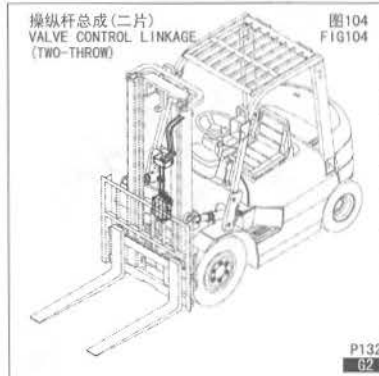
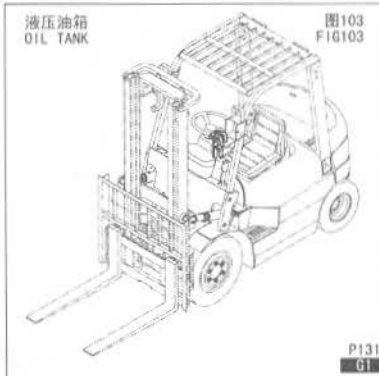
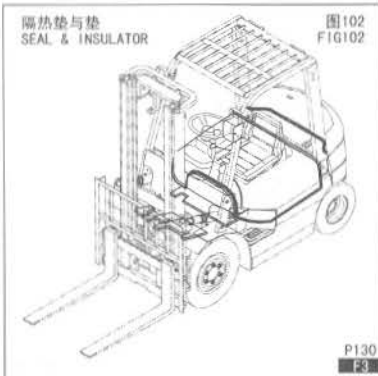
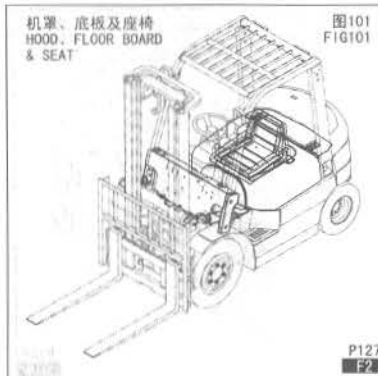
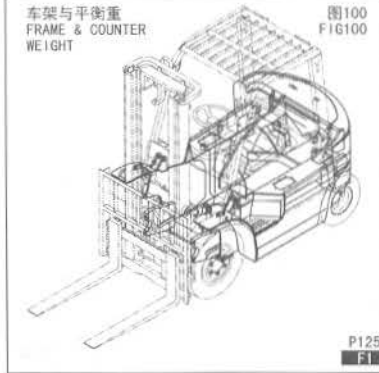
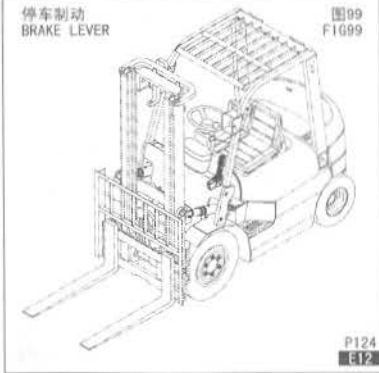
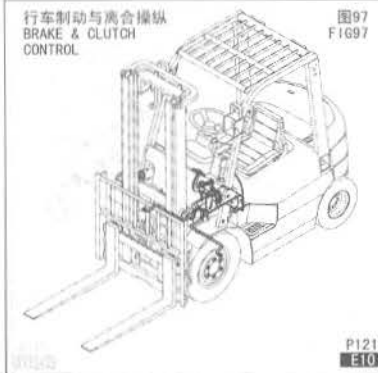

E

F

G

目录 INDEX

液压系统
HYDRAULIC SYSTEM



图109
FIG109

P139
G7

液压系统
HYDRAULIC SYSTEM

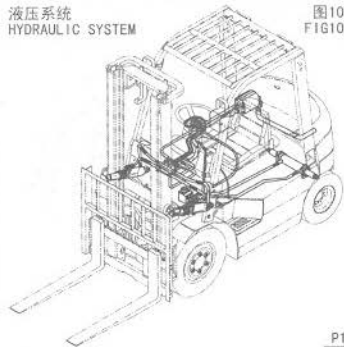

图110
FIG110

P142
G8

液压系统
HYDRAULIC SYSTEM

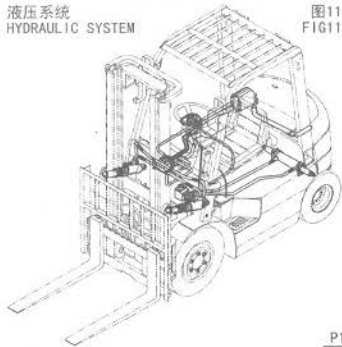

图111
FIG111

P144
G9

液压系统
HYDRAULIC SYSTEM

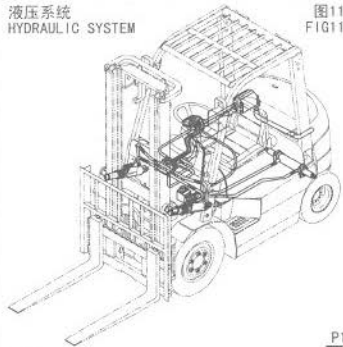

图112
FIG112

P146
G10

液压系统
HYDRAULIC SYSTEM

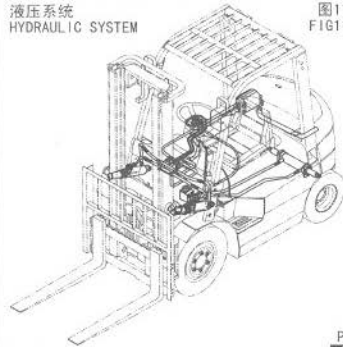

图113
FIG113

P149
G11

液压系统
HYDRAULIC SYSTEM

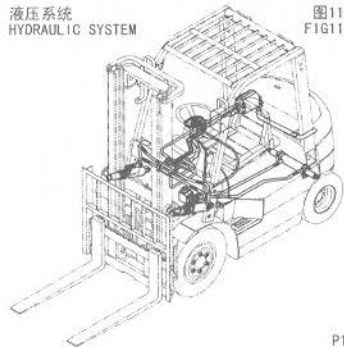

图114
FIG114

P151
G12

变矩器油冷系统
COOLING SYSTEM

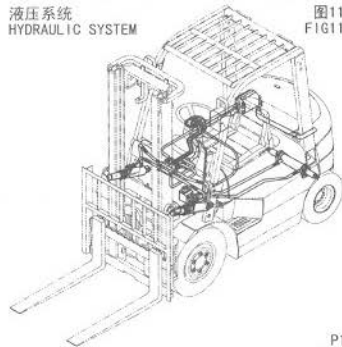

图115
FIG115

P153
G13

门架管路系统(基本型2~3t)
HYDRAULIC SYSTEM MAST
(NORMAL MAST M)

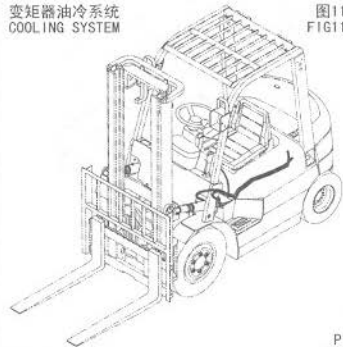

图116
FIG116

P154
G14

门架管路系统(基本型3.5t)
HYDRAULIC SY



图117
FIG117

P156
G15

门架管路系统(2~3t
二级全自由)
HYDRAULIC SYSTEM
MAST(FULL
FREE 2-STAGE
MAST ZM)



图118
FIG118

P158
G16

门架管路系统(3.5t
二级全自由)
HYDRAULIC SYSTEM
MAST(FULL
FREE 2-STAGE
MAST ZM)

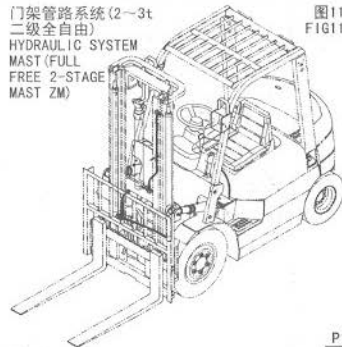

图119
FIG119

P162
G17

货叉(基本及二级全自由)
FORK(NORMAL & FULL
FREE 2-STAGE
MAST M & ZM)

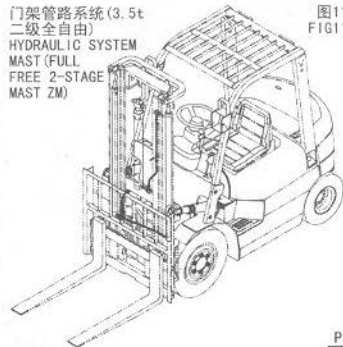

图120
FIG120

P164
H1

目录 INDEX

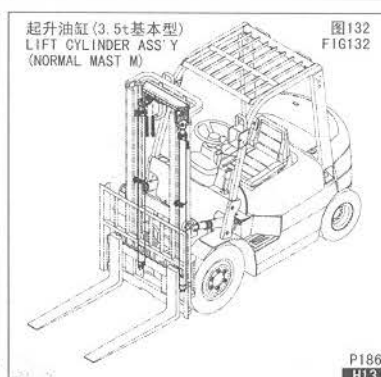
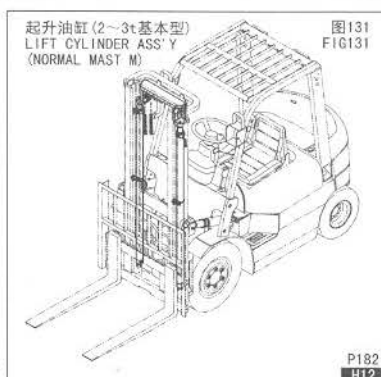
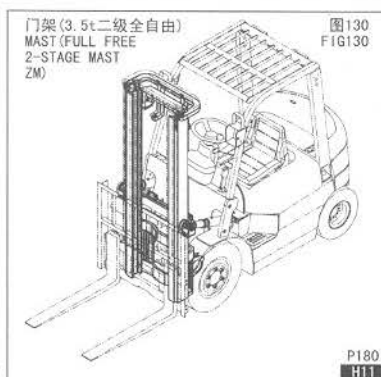
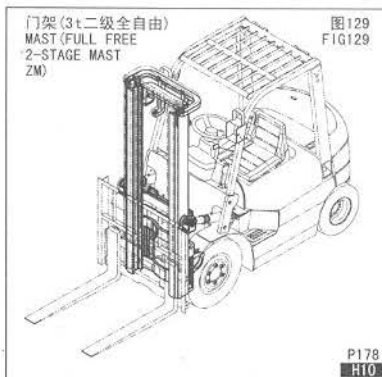
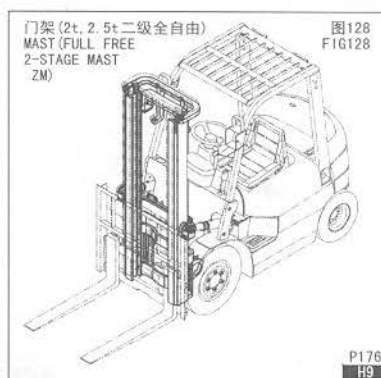
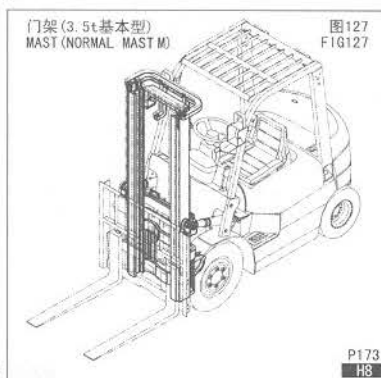
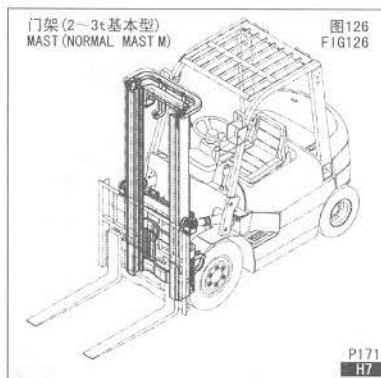
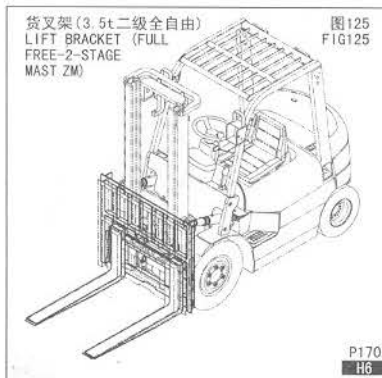
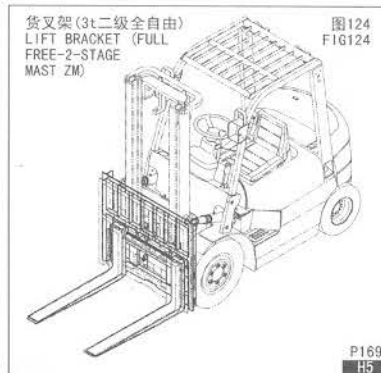
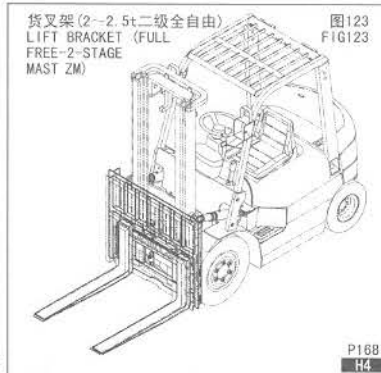
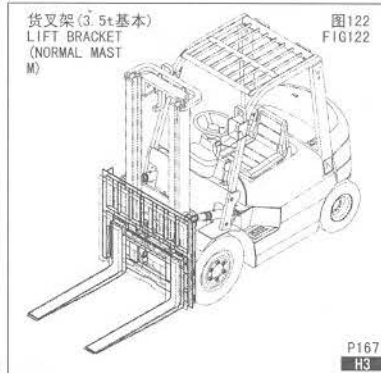
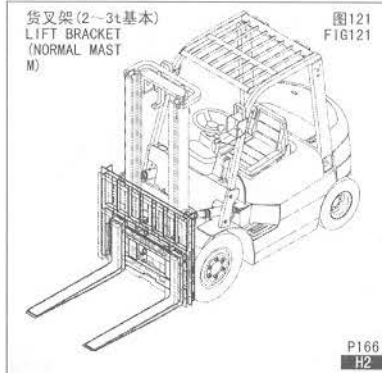

目录 INDEX

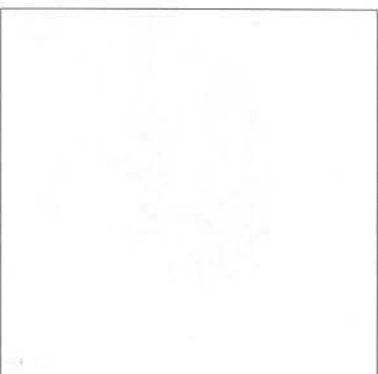
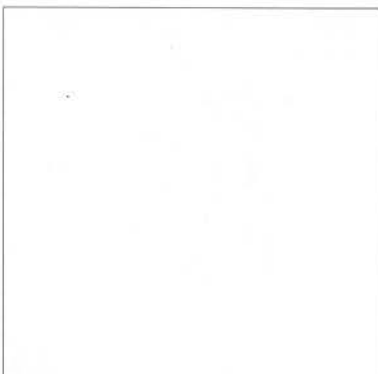
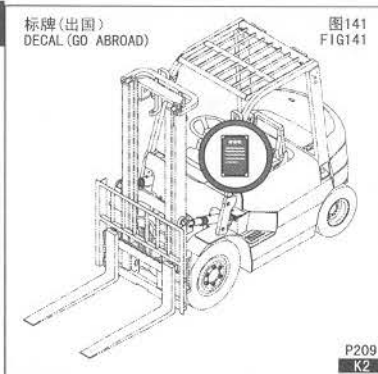
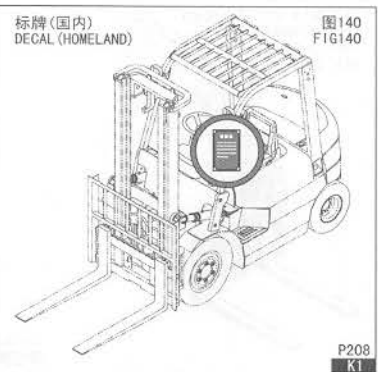
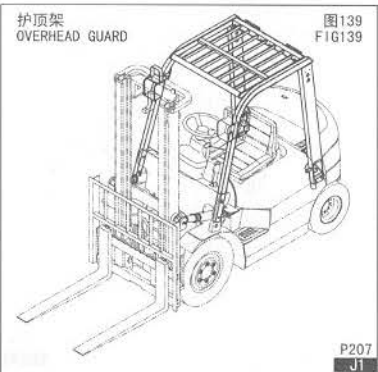
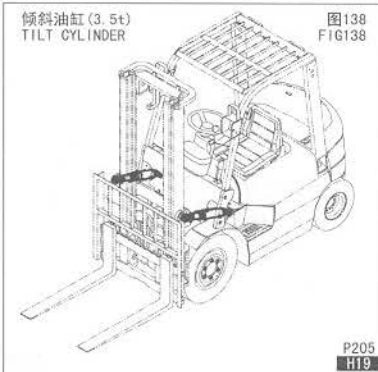
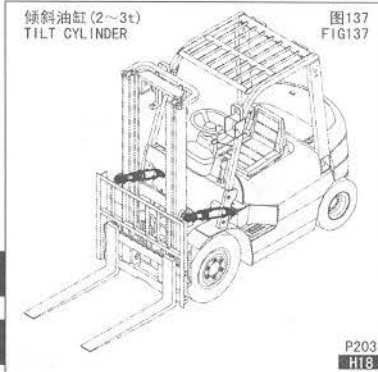

H

J

K

序号 Item No	图号 Part No	零部件名称 Description	件数 Q'ty	备注 Remark
01	B0230-10100	Bolt 螺栓M10×100	2	GB5782-86
02	23651-02001	Plate 垫片	2	
03	H25S1-02001	Coller 套管	2	
04	H24C1-02001	Rubber 橡胶垫	2	
05	A22A1-02011	Rubber 橡胶垫	2	
06	A22A1-02041	Washer 垫圈	2	
07	B4017-00010	Nut 螺母M10	2	GB6184-86
08	H24C1-00201	Air cleaner ass'y 空滤器安装	1	日产汽油机 See Fig.8
09	H20KA4GR00/ 10100-K9600	Engine H20KA4GR00发动机	1	CPQ(D)20,25-R6 CPQ(D)30-R12 CPQ(D)35-R4
-	H25KA4GR00/ 10100-K9700	Engine H25KA4GR00发动机	1	CPQ(D)20H,25H-R11 CPQ(D)30-R6 CPQ(D)35-R3

CPQ,CPQD20,25,30-R6
CPQ,CPQD20H,25H-R11
CPQ,CPQD30-R12
CPQ,CPQD35-R3,R4

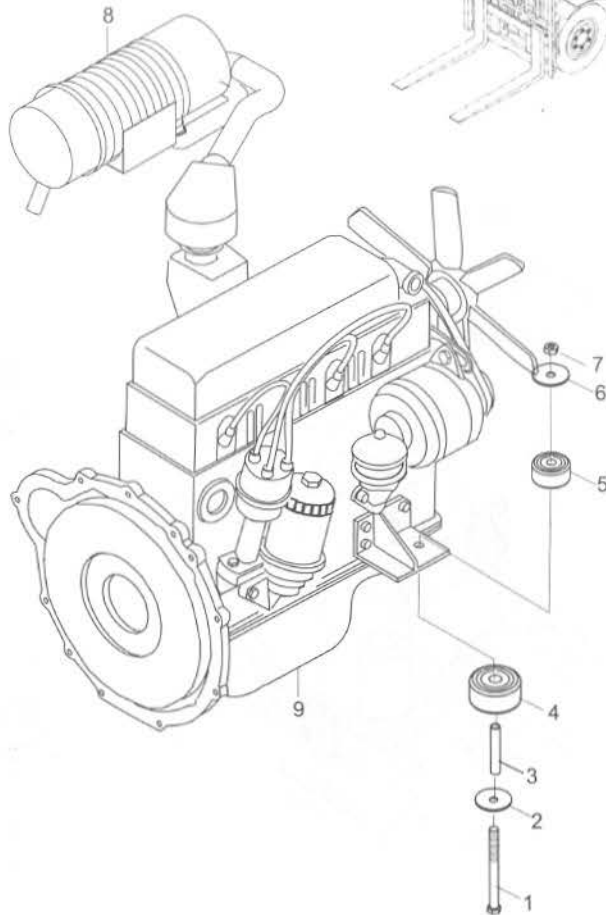

CPC,CPCD20,25,30-W7,W8,W9
CPC,CPCD20,25,30-Xs1,X6
CPC,CPCD35-W4,W5,W6,X2,Xs1

序号 Item No	图号 Part No	零部件名称 Description	件数 Q'ty	备注 Remark
01	B0230-10100	Bolt 螺栓M10×100	2	
02	23651-02001	Plate 垫片	2	
03	H25S1-02001	Coller 套管	2	
04	H24C1-02001	Rubber 橡胶垫	2	CPC(D)20-30-X6 CPC(D)20-30-W7,W9 CPC(D)20-35-Xs1 CPC(D)35-W5,W6,X2
-	H24C1-02001	Rubber 橡胶垫	4	CPC(D)20-30-W8 CPC(D)35-W4
05	A22A1-02011	Rubber 橡胶垫	2	CPC(D)20-30-X6 CPC(D)20-30-W7,W9 CPC(D)20-35-Xs1 CPC(D)35-W5,W6,X2
06	A22A1-02041	Washer 垫圈	2	CPC(D)20-30-X6 CPC(D)20-30-W7,W9 CPC(D)20-35-Xs1 CPC(D)35-W5,W6,X2
-	H24C1-02011	Washer 垫圈	2	CPC(D)20-30-W8 CPC(D)35-W4 除CPC(D)20-30-X6 CPC(D)35-X2外
07	B4017-00010	Nut 螺母M10	2	GB6184-86 CPC(D)20-30-X6
-	B7720-00010	Nut 螺母M10	2	GB889-86 CPC(D)35-X2
08	H25S1-00201	Air cleaner ass'y 空滤器安装	1	CPC(D)20-30-W7,W9 CPC(D)35-W5,W6 See Fig.12
-	H25T1-00201	Air cleaner ass'y 空滤器安装	1	CPC(D)20-30-W8 CPC(D)35-W4 See Fig.11
-	H2B11-00211	Air cleaner ass'y 空滤器安装	1	CPC(D)20-35-Xs1 See Fig.9
-	H9A11-00201	Air cleaner ass'y 空滤器安装	1	CPC(D)20-30-X6 CPC(D)35-X2 See Fig.13
09	H9A11-00301	Engine 新昌A490BPG发动机	1	CPC(D)20-30-X6 CPC(D)35-X2
-	524H2-70012	Engine C240PKJ-17柴油机	1	CPC(D)20-30-W7 CPC(D)35-W5
-	H23U1-02001	Engine 4JG2PE-01柴油机	1	CPC(D)20-30-W8 CPC(D)35-W4
-	H25U1-00101	Engine C240PKJ-20发动机	1	CPC(D)20-30-W9 CPC(D)35-W6
-	H21U1-00201	Engine 4D95LE-3柴油机	1	CPC(D)20-35-Xs1
10	HRH46E1001 H46E1-00211	Packet L.H. 发动机支脚(左)	1	CPC(D)20-35-Xs1



图3/FIG3

发动机(柴油机)/ENGINE(DIESEL)

A3

序号 Item No	图号 Part No	零部件名称 Description	件数 Q'ty	备注 Remark
A	H99Y1-00001	Engine 发动机安装	1	
01	H99Y1-00201	Diesel CA498-12型柴油机	1	
02	H99Y1-00301	Air cleaner ass'y 空滤器安装	1	见图9 See Fig.9
03	B0230-10100	Bolt 螺栓M10×100	2	GB5782-86
04	Z3651-02001	Plate 垫片	2	
05	H25S1-02001	Coller 套管	2	
06	H24C1-02001	Rubber 橡胶垫	4	
07	H24C1-02011	Washer 垫圈	2	
08	B7720-00010	Nut 螺母M10	2	GB889-86

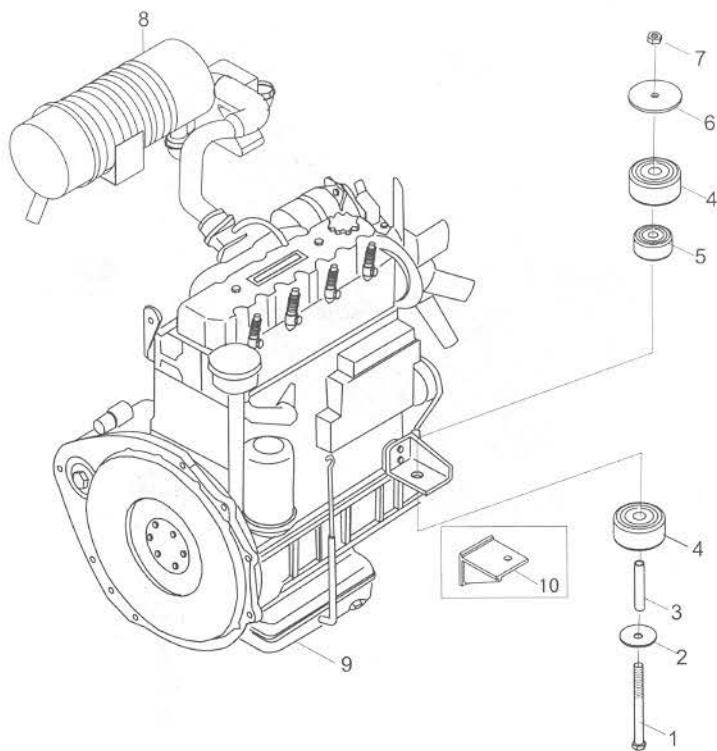
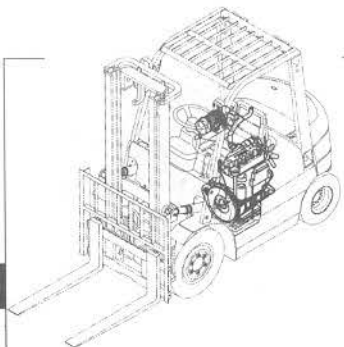
CPC,CPCD20,25,30,35-D

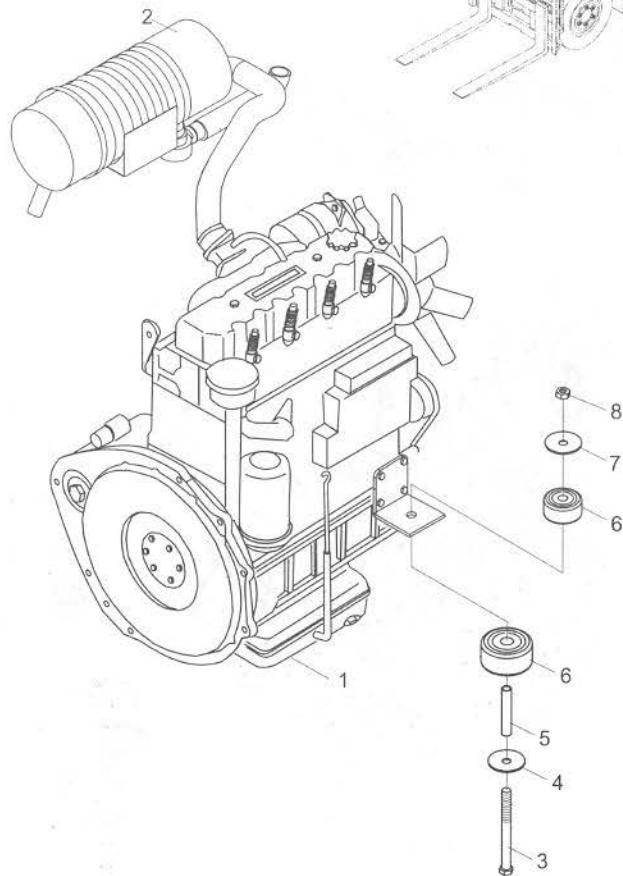
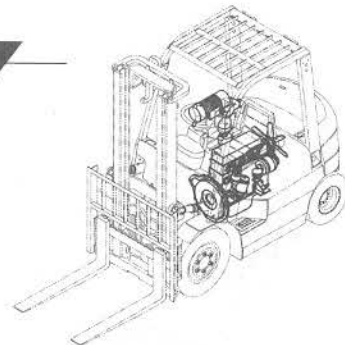

A

CPC,CPCD20,25,30,35-HJ

序号 Item No	图号 Part No	零部件名称 Description	件数 Q'ty	备注 Remark
01	E24C1-00001	Engine HJ493型柴油机	1	
02	H97Y1-00301	Air cleaner ass'y 空滤器安装	1	See Fig.13
03	A22A1-02041	Washer 垫圈	2	
04	23651-02001	Plate 垫片	2	
05	F390-28-52-7	Fan 排风扇	1	
06	H25S1-02001	Coller 套管	2	
07	B0230-10100	Bolt 螺栓M10X100	2	GB5782-86
08	H97Y1-00401	Engine support L.H. 发动机左支架	1	
09	B4016-00010	Nut 螺母M10	2	GB6184-86
10	H97Y1-00221	Engine support R.H. 发动机右支架	1	
11	H24C1-02001	Rubber 橡胶垫	2	
12	22571-02011	Rubber 橡胶垫	2	
13	B0530-10035	Bolt 螺栓M10X1.25X35	3	GB5786-86



图5 / FIG5

发动机(汽油机)/ENGINE (GASOLINE)

A5

序号 Item No	图号 Part No	零部件名称 Description	件数 Q'ty	备注 Remark
A	H98T1-00001	Engine setting	1	发动机安装 CPQ(D)20-35-ZJ2
-	H90Z1-00001	Engine setting	1	发动机安装 CPQ(D)20-35-ZJ3
01	B0230-10100	Bolt	2	螺栓M10×100 GB5782-86
02	23651-02001	Plate	2	垫片
03	H25S1-02001	Coller	2	套管
04	H24C1-02001	Rubber	2	橡胶垫
05	A22A1-02011	Rubber	2	橡胶垫
06	A22A1-02041	Washer	2	垫圈
07	B4016-00010	Nut	2	螺母M10 GB6184-86
08	H94N1-00201	Air cleaner ass'y	1	空滤器安装 CPQ(D)20-35-ZJ2 See Fig.10
-	H96N1-00201	Air cleaner ass'y	1	空滤器安装 CPQ(D)20-35-ZJ3 See Fig.10
09	E98T1-00001	Engine	1	HW491GP带泵汽油机 CPQ(D)20-35-ZJ2
-	E90Z1-00001	Engine	1	HW491GPE电喷带泵汽油机 CPQ(D)20-35-ZJ3
10	E94N1-42151	Spacer	1	风扇电块 CPQ(D)20-35-ZJ2
-	E90Z1-42031	Spacer	1	风扇电块 CPQ(D)20-35-ZJ3
11	H94N1-02041	Bolt	4	螺栓 CPQ(D)20-35-ZJ2
-	E90Z1-42041	Bolt	4	螺栓 CPQ(D)20-35-ZJ3
12	H94N1-02031	Board	1	点火线圈安装板 CPQ(D)20-35-ZJ2

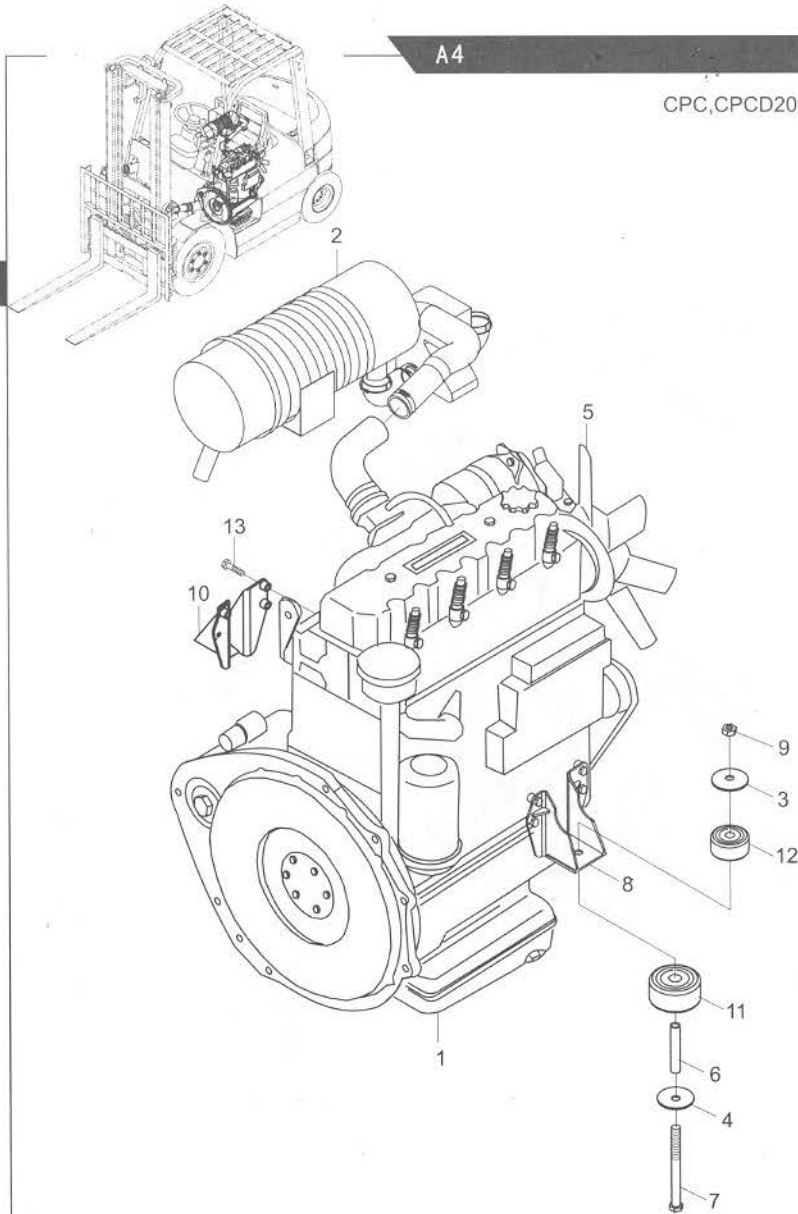
CPQ,CPQD20,25,30,35-ZJ2,ZJ3

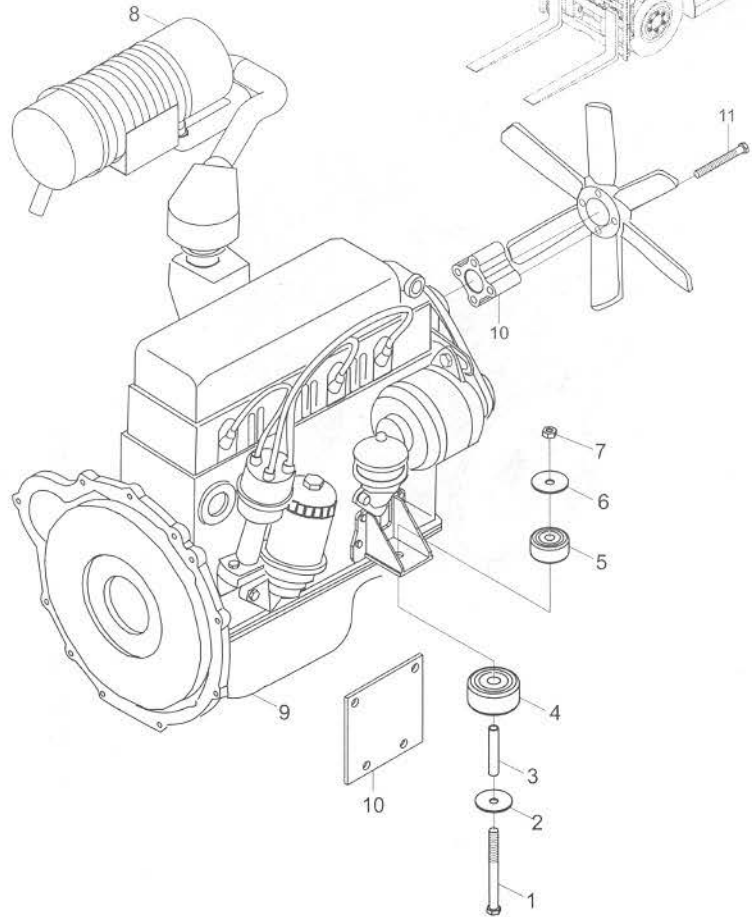

A

CPC,CPCD20,25,30-Ku1

序号
Item
No图号
Part No零部件名称
Description件数
Q'ty备注
Remark

A	H2B91-00001	Engine setting	发动机安装	1	
01	H2B91-00201	Engine	久保田V2403发动机	1	
02	H2B91-00301	Air cleaner ass'y	空滤器安装	1	See Fig.7
03	B0230-10100	Bolt	螺栓M10x100	2	GB5782-86
04	23651-02001	Plate	垫片	2	
05	H25S1-02001	Coller	套管	2	
06	H24C1-02001	Rubber	橡胶垫	2	
07	A22A1-02011	Rubber	橡胶垫	2	
08	A22A1-02041	Washer	垫圈	2	
09	B4023-00010	Nut	螺母M10	2	GB6184-86
10	B0530-12025	Bolt	螺栓M12x1.25x25	6	GB5786-86
11	B5050-00012	Washer,lock	垫圈12	6	GB93-87
12	H2B91-00401	Engine support R.H.	发动机右支架	1	
13	H2B91-00501	Engine support L.H.	发动机左支架	1	

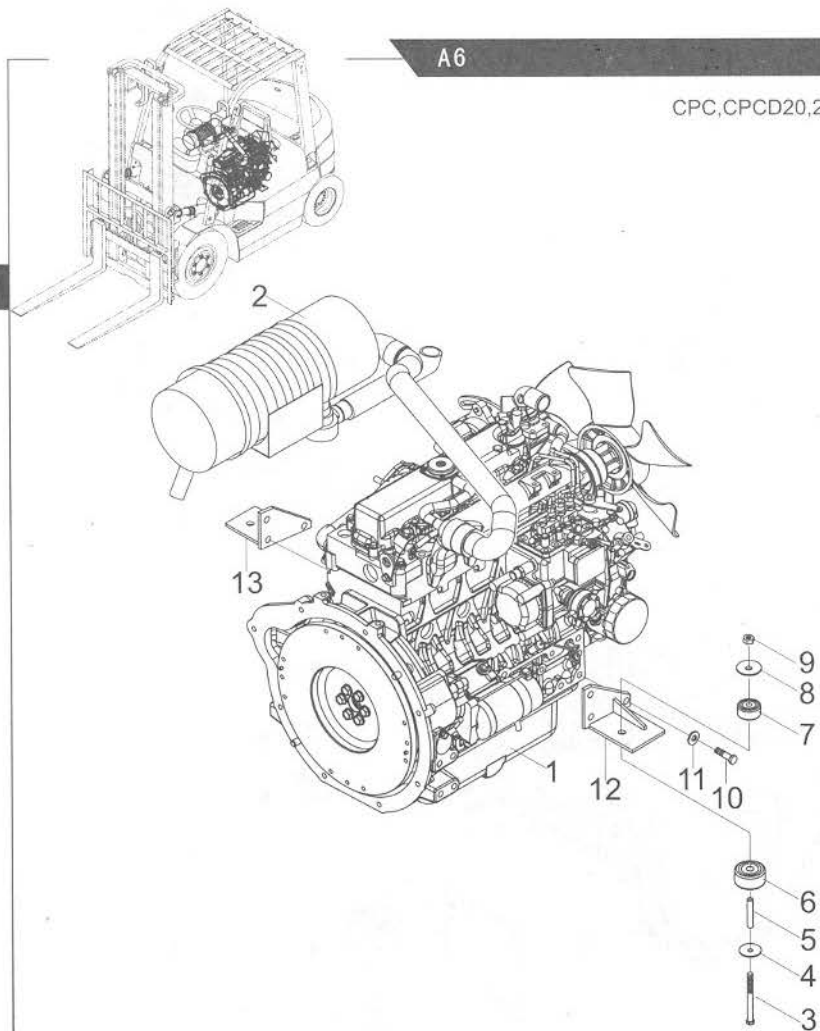

序号 Item No	图号 Part No	零部件名称 Description	件数 Q'ty	备注 Remark
A	H2B91-00301	Aire cleaner ass'y	空滤器安装	1
01	B0330-08016	Bolt	螺栓M8×16	4 GB5783-86
02	B5050-00008	Washer,lock	垫圈8	4 GB93-87
03	H24C1-02043	Duct	进气管	1
04	H2B91-02011	Hose	空滤器管	1
05	H99Y1-00311	Air cleaner	空气滤清器	1
06	H99Y1-02011	Bracket	支架	1
07	Z4590-00068	Clip	双钢丝卡箍φ68	4
08	B5310-00008	Wsher	垫圈8	2 GB97.1-85

CPC,CPCD20,25,30-Ku1

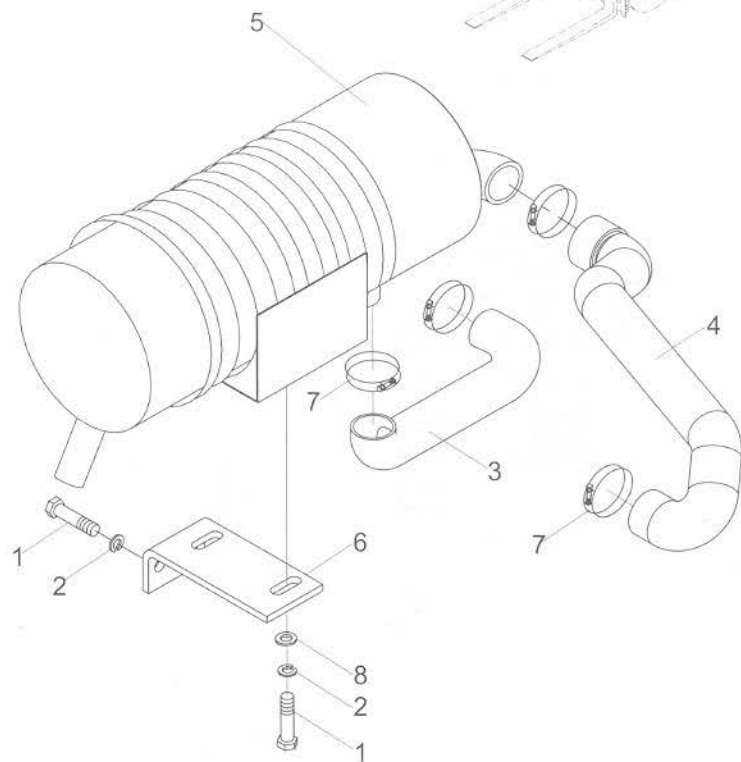
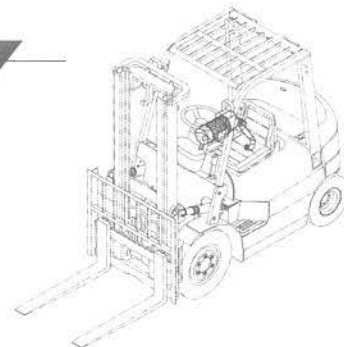

CPQ,CPQD20,25,30-R6
 CPQ,CPQD20H,25H-R11
 CPQ,CPQD30-R12
 CPQ,CPQD35-R3,R4

序号 Item No	图号 Part No	零部件名称 Description	件数 Q'ty	备注 Remark
A	H24C1-00201	Air cleamer ass'y	空滤器安装	1
01	Z4590-00060	Clip	双钢丝卡箍 ϕ 60	4
02	H24C1-00211	Air cleaner (Inc.10)	空滤器	1
03	H24C1-02051	Hose	空滤器管	1
04	H24C1-02022	Bracker	支架	1
05	B0330-08016	Bolt	螺栓M8×16	2 GB5783-86
06	B5050-00008	Washer,lock	垫圈8	4 GB93-87
07	B4230-00008	Nut	螺母M8X1	2 GB6171-86
08	H24C1-02043	Duct	进气管	1
09	B5310-00008	Washer	垫圈8	2 GB97.1-85
10	H24C1-00211X	Filter	滤芯	1



图9/FIG9

空滤器安装 /AIR CLEANER ASS'Y

A9

序号 Item No	图号 Part No	零部件名称 Description	件数 Q'ty	备注 Remark
A	H99Y1-00301	Air cleaner ass'y	空滤器安装	1 CPC(D)20~35-D
-	H2B11-00211	Air cleaner ass'y	空滤器安装	1 CPC(D)20~35-Xs1
01	Z4590-00060	Clip	双钢丝卡箍 \varnothing 60	4 CPC(D)20~35-D
-	Z4590-00068	Clip	双钢丝卡箍 \varnothing 68	4 CPC(D)20~35-Xs1
02	H24C1-02043	Duct	进气管	1
03	H99Y1-00311	Air cleaner (Inc.09)	空气滤清器	1
04	H99Y1-02011	Bracket	支架	1
05	B0520-08016	Bolt	螺栓M8X16	4 GB5786-86
06	B5050-00008	Washer,lock	垫圈8	4 GB93-87
07	B5130-00008	Washer	垫圈8	2 GB97.1-85
08	H99Y1-02001	Hose	空滤器管	1
09	H99Y1-00311X	Filter	滤芯	1

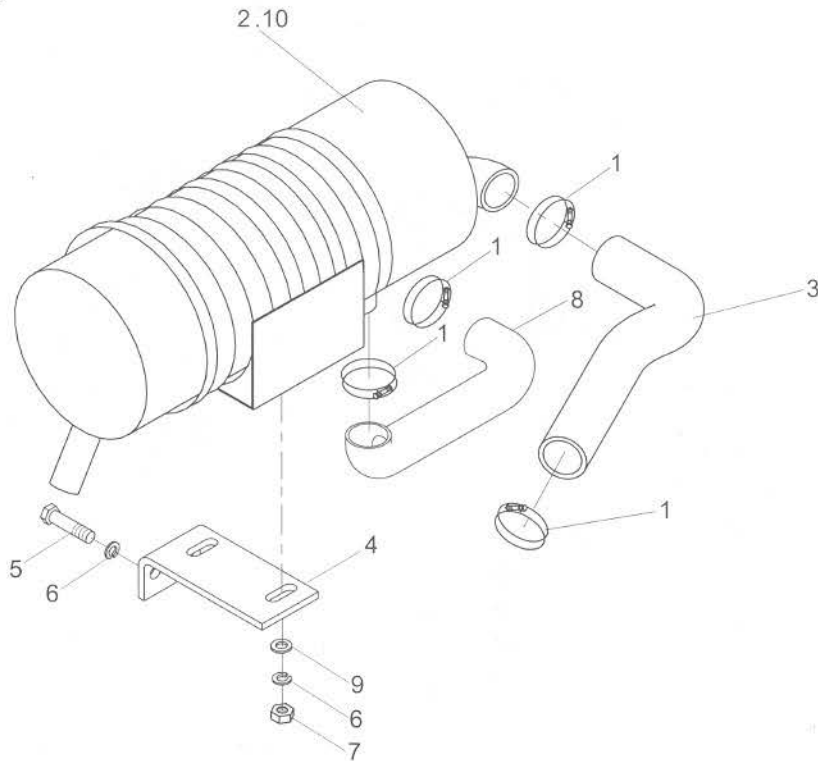
CPC,CPCD20,25,30,35-D,Xs1

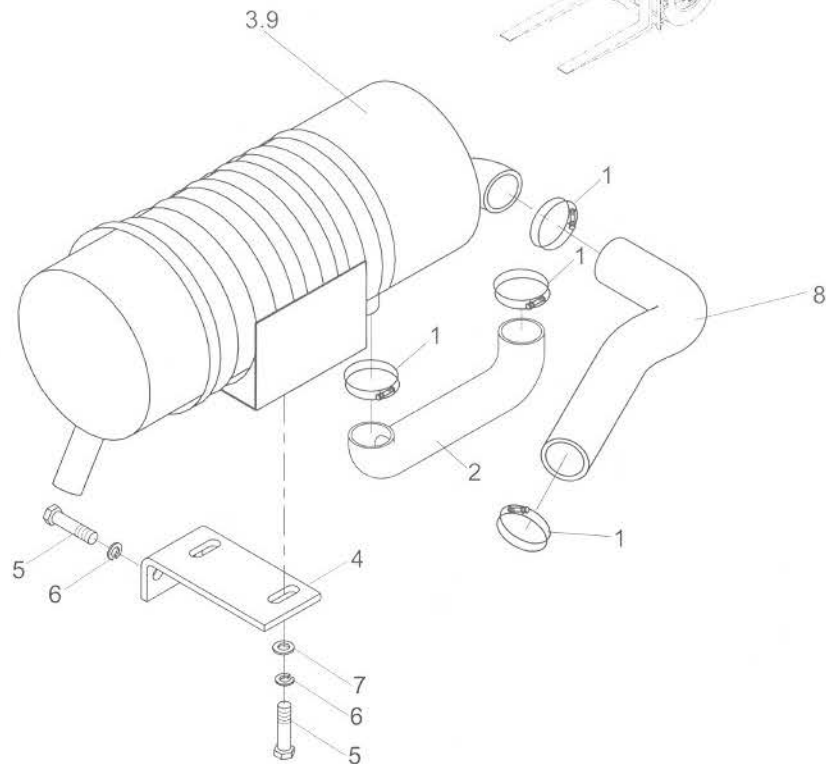
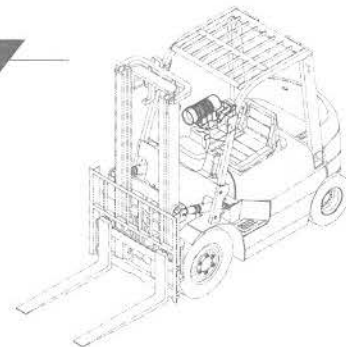

A

CPQ,CPQD20~35-ZJ2,ZJ3

序号 Item No	图号 Part No	零部件名称 Description	件数 Q'ty	备注 Remark
A	H94N1-00201	Air cleaner ass'y	1	空滤器安装 CPQ(D)20~35-ZJ2
-	H96N1-00201	Air cleaner ass'y	1	空滤器安装 CPQ(D)20~35-ZJ3
01	Z4590-00060	Clip	1	双钢丝卡箍 $\varnothing 60$
02	H99Y1-00311	Air cleaner (Inc.10)	1	空气滤清器
03	H94N1-02001	Hose	1	空滤器管 CPQ(D)20~35-ZJ2
-	H96N1-02001	Hose	1	空滤器管 CPQ(D)20~35-ZJ3
04	H99Y1-02011	Bracker	1	支架
05	B0330-08016	Bolt	4	螺栓M8 \times 16 GB5783-86
06	B5050-00008	Washer,lock	4	垫圈8 GB93-87
07	Z4590-00068	Clip	3	双钢丝卡箍 $\varnothing 68$
08	H24C1-02043	Duct	1	进气管
09	B5310-00008	Washer	2	垫圈8 GB97.1-85
10	H99Y1-00311X	Filter	1	滤芯



图11/FIG11

空滤器安装(柴油机)/AIR CLEANER ASS'Y(DIESEL)

A11

序号 Item No	图号 Part No	零部件名称 Description	件数 Q'ty	备注 Remark
A	H25T1-00201	Air cleaner ass'y	1	空滤器安装
01	H25S1-00223	Resonator	1	进气消声器
02	H25S1-00212X	Filter	1	滤芯
03	H25S1-02051	Duct	1	进气管接头A
04	Z4590-00068	Clip	4	双钢丝卡箍 \varnothing 68
05	H97Y1-02081	Duct	1	进气管接头B
06	B4116-00006	Nut	1	螺母M6-6H
07	B0520-08016	Bolt	6	螺栓M8 \times 1.25 \times 16
08	B5310-00008	Washer	2	垫圈8
09	B5050-00008	Washer	4	垫圈8
10	H99Y1-02011	Bracker	1	支架
11	H99Y1-00311	Air cleaner (Inc.15)	1	空气滤清器
12	H25T1-02001	Hose	1	空滤器管
13	Z4590-00075	Clip	1	双钢丝卡箍 \varnothing 75
14	Z4590-00065	Clip	1	双钢丝卡箍 \varnothing 65

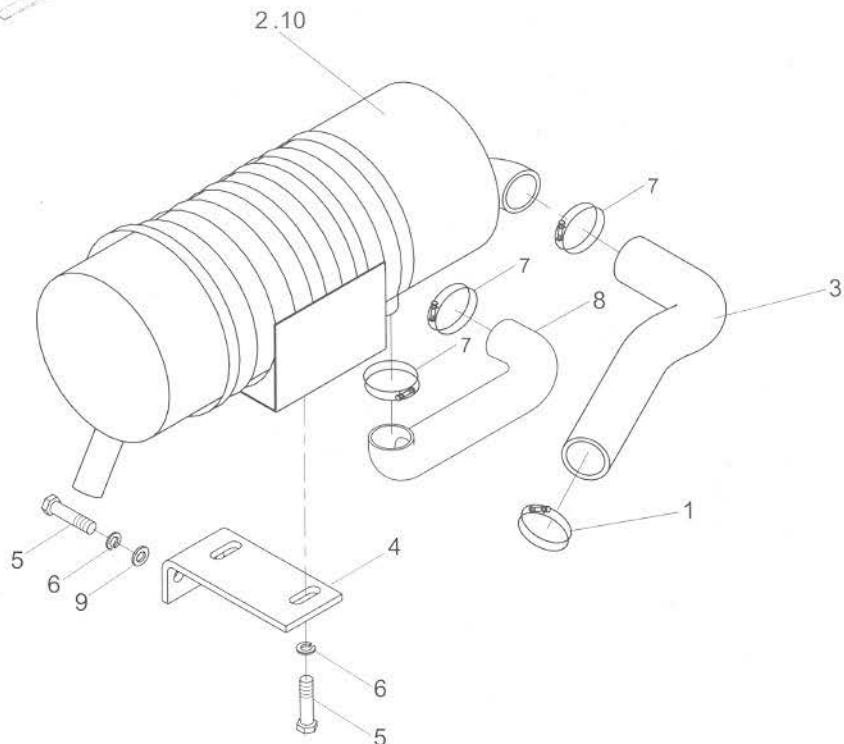
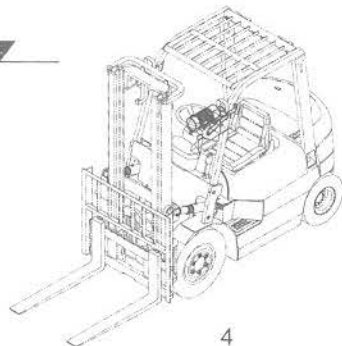
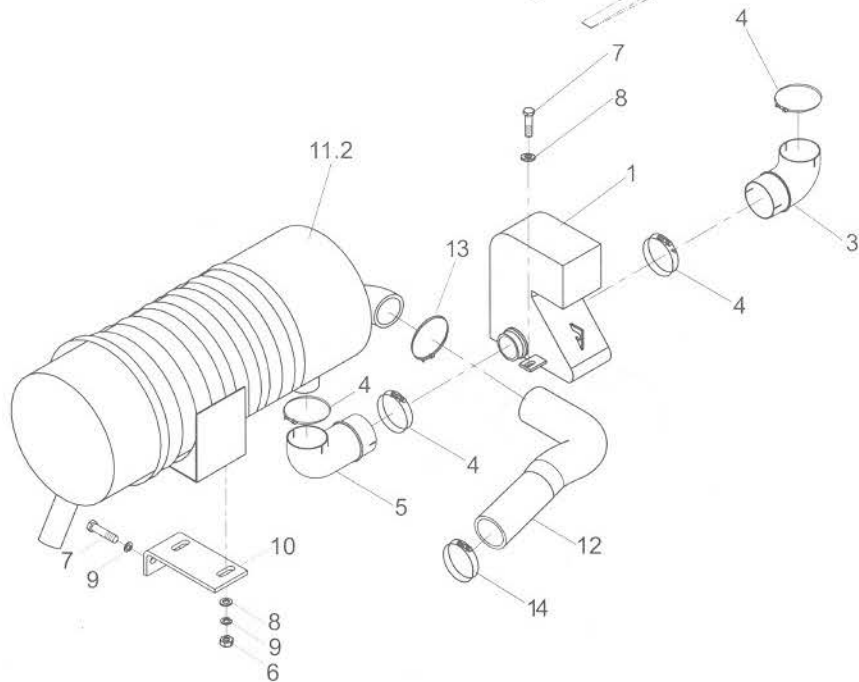
CPC,CPCD20,25,30-W8
CPC,CPCD35-W4

A

CPC,CPCD20,25,30-W7,W9
CPC,CPCD35-W5,W6

序号 Item No	图号 Part No	零部件名称 Description	件数 Q'ty	备注 Remark	
A	H25S1-00201	Air cleaner ass'y	空滤器安装	1	
01	H25S1-00223	Resonator	进气消声器	1	
02	Z4590-00060	Clip	双钢丝卡箍 $\phi 60$	1	
03	H25S1-02051	Duct	进气管接头A	1	
04	B4230-00008	Nut	螺母M8X1	2	GB6171-86
05	H97Y1-02081	Duct	进气管接头B	1	
06	B0330-08016	Bolt	螺栓M8X16	4	GB5783-86
07	B5310-00008	Washer	垫圈8	4	GB97.1-85
08	B5050-00008	Washer,lock	垫圈8	6	GB93-87
09	H99Y1-02011	Bracker	支架	1	
10	H99Y1-00311	Air cleaner(Inc.14)	空气滤清器	1	
11	H25S1-02021	Hose	空滤器管	1	
12	Z4590-00075	Clip	双钢丝卡箍 $\phi 75$	1	
13	Z4590-00068	Clip	双钢丝卡箍 $\phi 68$	4	
14	H99Y1-00311X	Filter	滤芯	1	



图13/FIG13

空滤器安装(柴油)/AIR CLEANER ASS'Y (DIESEL)

A13

序号 Item No	图号 Part No	零部件名称 Description	件数 Q'ty	备注 Remark
A	H97Y1-00301	Air cleaner ass'y	1	CPC(D)20-30-HJ
-	H9A11-00201	Air cleaner ass'y	1	CPC(D)20-30-X6 CPC(D)3.5-X2
01	H25S1-00223	Resonator	1	进气消声器
02	Z4590-00060	Clip	2	双钢丝卡箍 \varnothing 60
			3	CPC(D)20-30-HJ CPC(D)20-30-X6 CPC(D)3.5-X2
03	H25S1-02051	Duct	1	进气管接头A
04	Z4590-00055	Clip	1	双钢丝卡箍 \varnothing 55
			2	CPC(D)20-30-HJ CPC(D)20-30-X6 CPC(D)3.5-X2
05	H97Y1-02081	Duct	1	进气管接头B
06	Z4590-00068	Clip	3	双钢丝卡箍 \varnothing 68
07	B0330-08016	Bolt	6	螺栓M8 \times 16
08	B5310-00008	Washer	2	垫圈8
			4	GB5783-86 GB97.1-85 CPC(D)20-30-HJ CPC(D)20-30-X6 CPC(D)3.5-X2
09	B5050-00008	Washer	4	垫圈8
				GB93-87
10	H99Y1-02011	Bracker	1	支架
11	H99Y1-00311	Air cleaner(Inc.14)	1	空气滤清器
12	H97Y1-02061	Hose	1	空滤器管
-	H93C1-32202	Hose	1	CPC(D)20-30-HJ CPC(D)20-30-X6 CPC(D)3.5-X2
13	Z4590-00075	Clip	1	双钢丝卡箍 \varnothing 75
14	H99Y1-00311X	Filter	1	滤芯

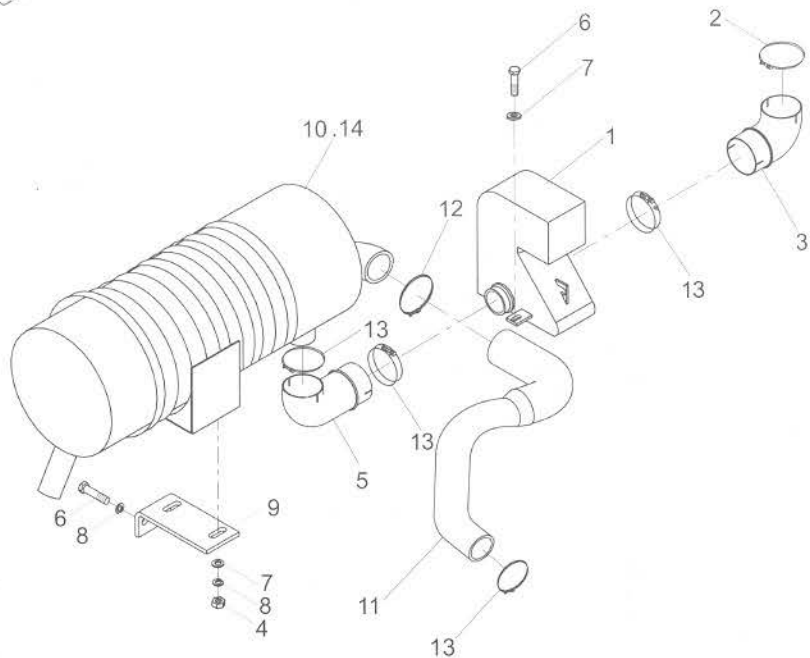
CPC,CPCD20,25,30,35-HJ
CPC,CPCD20,25,30-X6
CPC,CPCD35-X2

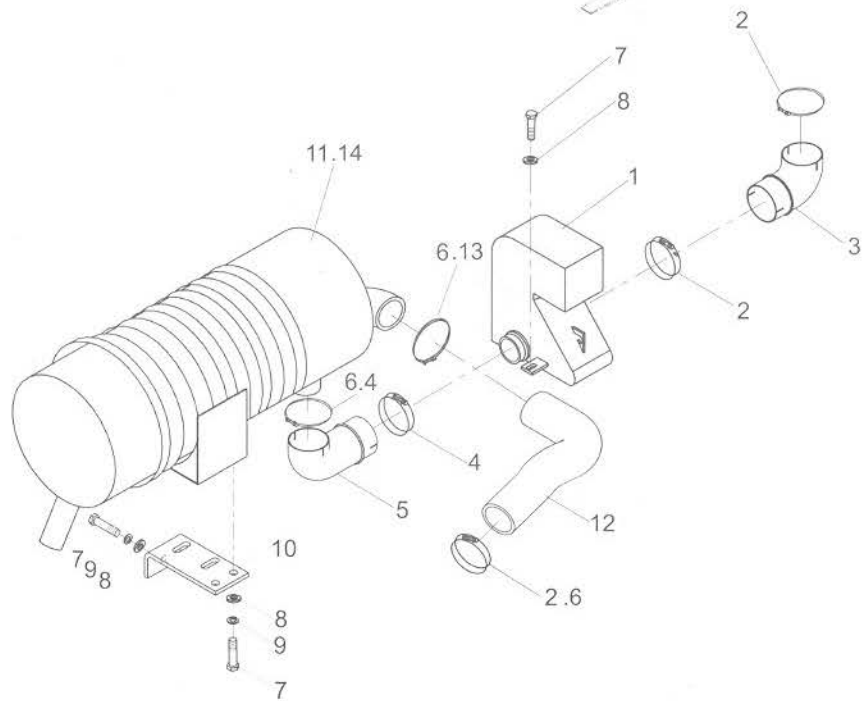

CPC,CPCD20,25,30-Ku1

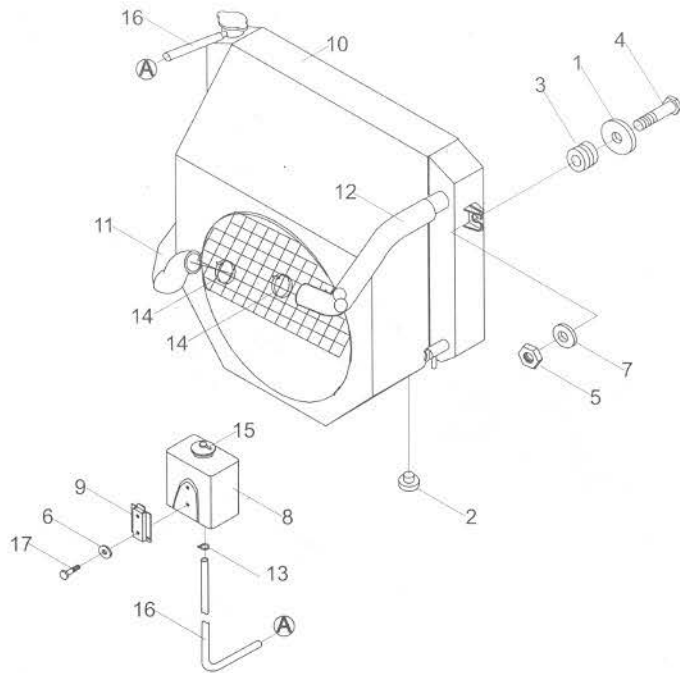
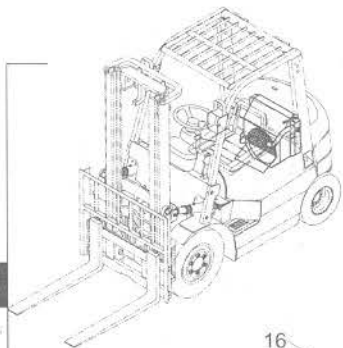

序号 Item No	图号 Part No	零部件名称 Description	件数 Q'ty	备注 Remark
A	HRH2B92101 H2A92-10001	Cooling system	冷却系统	1 CPC20,25,30
-	HRH2B92101 H2B92-10001	Cooling system	冷却系统	1 CPCD20,25,30
01	22252-32251	Washer	垫片	2
02	A22A2-12001	Rubber	橡胶垫 I	2
03	A22A2-12031	Rubber	橡胶垫 II	2
04	A22A2-12041	Bolt	螺栓	2
05	B4016-00008	Nut	螺母M8	2 GB6184-86
06	B5210-00006	Washer	垫圈6	2 GB96-85
07	B5210-00010	Washer	垫圈10	2 GB96-85
08	H24C2-10201	Tank	副水箱	1
09	H24C2-12011	Bracket	支架	1
10	H2A92-10201	Radiator	水箱总成	1 CPC20,25,30
-	H2B92-10201	Radiator	水箱总成	1 CPCD20,25,30
11	H2B92-12001	Hose,lower	下水管	1
12	H2B92-12011	Hose,upper	上水管	1
13	Z4590-00012	Clip	双钢丝紧箍 \varnothing 12	2
14	Z4590-00045	Clip	双钢丝卡箍 \varnothing 45	4
15	Z7400-08020	Pipe,vinyl	透明胶管 \varnothing 8x200	1
16	Z7500-08190	Hose	橡胶管 \varnothing 8x1900	1
17	B0330-06016	Bolt	螺栓M6x16	2 GB5783-86

图15/FIG15

冷却系统 / COOLING SYSTEM

A15

序号 Item No	图号 Part No	零部件名称 Description	件数 Q'ty	备注 Remark
01	H24C2-12001	Hose, lower	进水管	1 日产汽油机
-	H21U2-12011	Hose, lower	下水管	1 CPC(D)20-35-Xs1
-	H94N2-12001	Hose, lower	进水管	1 CPQD20-35-ZJ2,ZJ3
02	Z4590-00045	Clip	双钢丝卡箍 $\varnothing 45$	4
03	H24C2-10201	Tank	副水箱	1 除CPQ(D)20-35-ZJ2,ZJ3外
04	B0330-06016	Bolt	螺栓M6 \times 16	2 GB5783-86 除CPQ(D)20-35-ZJ2,ZJ3外
05	B5050-00006	Washer	垫圈6	2 GB93-87 除CPQ(D)20-35-ZJ2,ZJ3外
06	H24C2-12011	Bracket	支架	1 除CPQ(D)20-35-ZJ2,ZJ3外
07	Z4590-00012	Clip	双钢丝卡箍 $\varnothing 12$	2 除CPQ(D)20-35-ZJ2,ZJ3外
08	Z7500-08185	Hose	橡胶管 $\varnothing 8 \times 1850$	1 CPC(D)20-35-Xs1
-	Z7500-08190	Hose	橡胶管 $\varnothing 8 \times 1900$	1 日产汽油机
09	H24C2-12021	Hose, upper	出水管	1 日产汽油机
-	H21U2-12001	Hose, upper	上水管	1 CPC(D)20-35-Xs1
-	H94N2-12011	Hose, upper	出水管	1 CPQ(D)20-35-ZJ2,ZJ3
10	H24C2-10302	Radiator	水箱总成	1 日产汽油机械
✓	H24D2-10302	Radiator	水箱总成	1 日产汽油液力
-	HRH2B12101 H2A12-10201	Radiator	水箱总成	1 CPC20-35-Xs1
-	HRH2B12101 H2B12-10201	Radiator	水箱总成	1 CPCD20-35-Xs1
-	H94N2-10201	Radiator	水箱总成	1 CPQ20-35-ZJ3
-	H94T2-10201	Radiator	水箱总成	1 CPQD20-35-ZJ3
-	H98N2-10201	Radiator	水箱总成	1 CPQ20-35-ZJ2
-	H98T2-10201	Radiator	水箱总成	1 CPQD20-35-ZJ2
11	A22A2-12001	Rubber	橡胶垫I	2
12	A22A2-12031	Rubber	橡胶垫II	2
13	A22A2-12041	Bolt	螺栓	2
14	22252-32251	Washer	垫片	2
15	B4016-00008	Nut	螺母M8	2 GB6184-86
16	B5210-00010	Washer	垫圈10	2 GB96-85
17	Z7400-08020	Pipe, vinyl	透明胶管 $\varnothing 8 \times 200$	1 除CPQ(D)20-35-ZJ2,ZJ3外

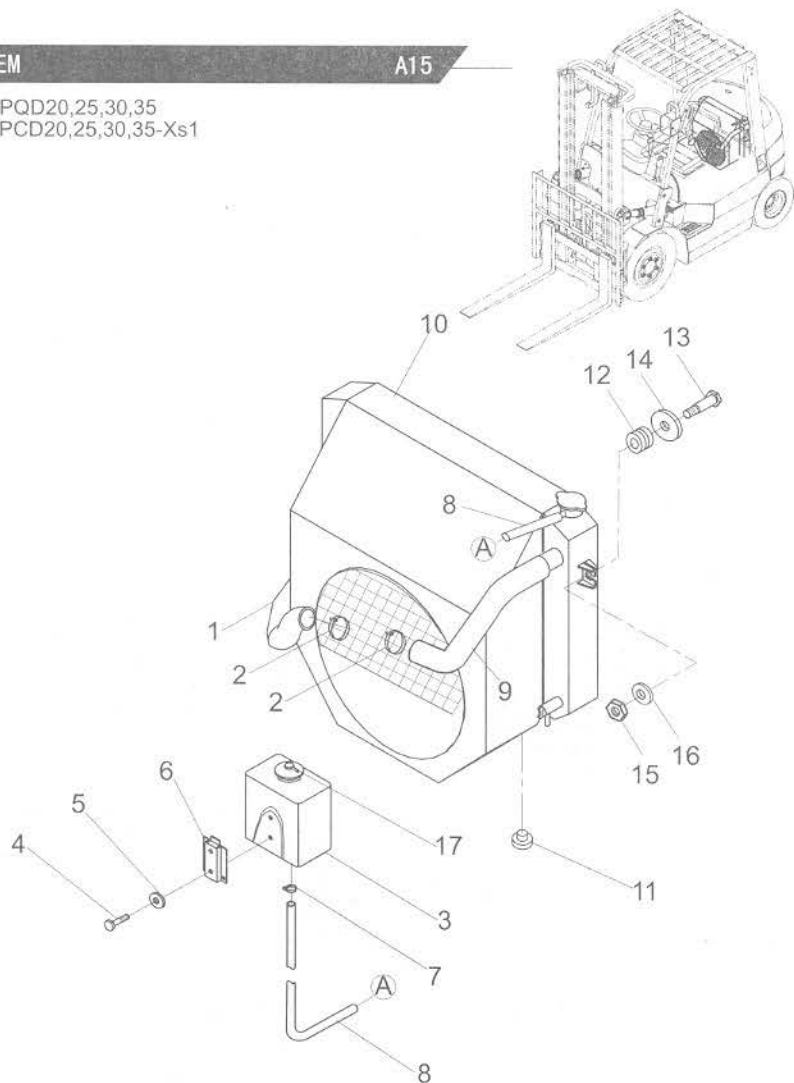
CPQ,CPQD20,25,30,35
CPC,CPCD20,25,30,35-Xs1

CPC,CPCD20,25,30-W7,W9
CPC,CPCD35-W5,W6

序号 Item No	图号 Part No	零部件名称 Description	件数 Q'ty	备注 Remark
01	H25S2-12001	Hose, upper	进水管 1	
02	Z4590-00045	Clip	双钢丝卡箍 $\varnothing 45$ 4	
03	H24C2-10201	Tank	付水箱 1	
04	B0330-06016	Bolt	螺栓M6 \times 16 2	GB5783-86
05	B5050-00006	Washer	垫圈6 2	GB93-87
06	H24C2-12011	Bracket	支架 1	
07	Z4590-00012	Clip	双钢丝卡箍 $\varnothing 12$ 2	
08	Z7500-08060	Hose	橡胶管 $\varnothing 8 \times 600$ 1	
09	H25S2-12011	Hose, lower	出水管 1	
10	H25S2-10202	Radiator	水箱总成 1	CPCD20,25,30,35
11	H25C2-10202	Radiator	水箱总成 1	CPC20,25,30,35
12	A22A2-12001	Rubber	橡胶垫 I 2	
13	A22A2-12031	Rubber	橡胶垫 II 2	
14	A22A2-12041	Bolt	螺栓 2	
15	22252-32251	Washer	垫片 2	
16	B4016-00008	Nut	螺母M8 2	GB6184-86
17	B5210-00010	Washer	垫圈10 2	GB96-85
18	Z7400-08020	Pipe, vinyl	透明胶管 $\varnothing 8 \times 200$ 1	



图17/FIG17

冷却系统(柴油机)/COOLING SYSTEM(DIESEL)

A17

序号 Item No	图号 Part No	零部件名称 Description	件数 Q'ty	备注 Remark
01	H25N2-12001	Hose, upper 进水管	1	
02	Z4590-00045	Clip 双钢丝卡箍 $\varnothing 45$	4	
03	H24C2-10201	Tank 付水箱	1	
04	B0330-06016	Bolt 螺栓M6 \times 16	2	GB5783-86
05	B5050-00006	Washer 垫圈6	2	GB93-87
06	H24C2-12011	Bracket 支架	1	
07	Z4590-00012	Clip 双钢丝卡箍 $\varnothing 12$	2	
08	Z7500-08190	Hose 橡胶管 $\varnothing 8 \times 1900$	1	
09	H25N2-12011	Hose, lower 出水管	1	
10	H25N2-10202	Radiator 水箱总成	1	CPC20-30-W8 CPC35-W4
11	H25T2-10202	Radiator 水箱总成	1	CPCD20-30-W8 CPCD35-W4
12	A22A2-12001	Rubber 橡胶垫 I	2	
13	A22A2-12031	Rubber 橡胶垫 II	2	
14	A22A2-12041	Bolt 螺栓	2	
15	22252-32251	Washer 垫片	2	
16	B4016-00008	Nut 螺母M8	2	GB6184-86
17	B5210-00010	Washer 垫圈10	2	GB96-85
18	Z7400-08020	Pipe, vinyl 透明胶管 $\varnothing 8 \times 200$	1	
19	H25N2-12531	Bracket 付水箱支架	1	

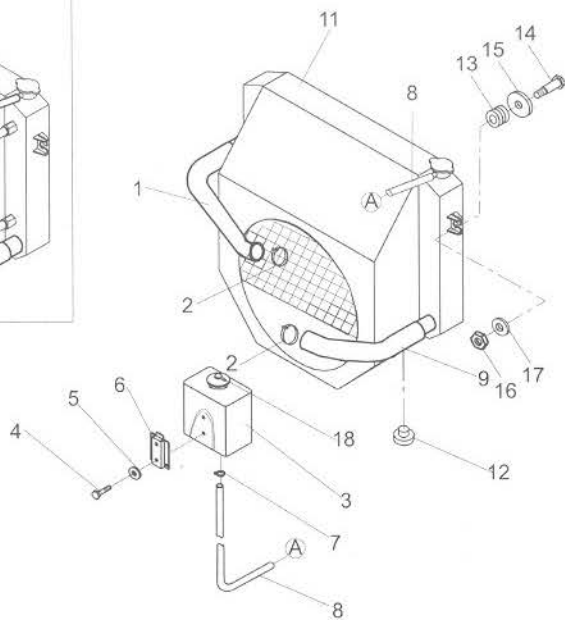
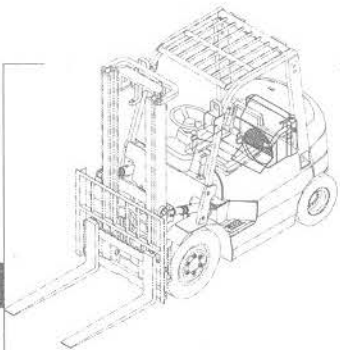
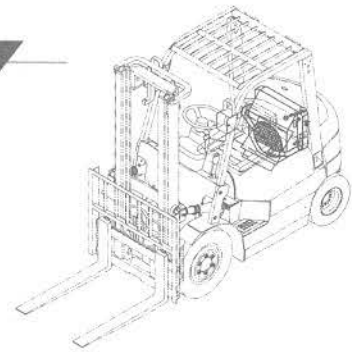
CPC,CPCD20,25,30-W8
CPC,CPCD35-W4

A

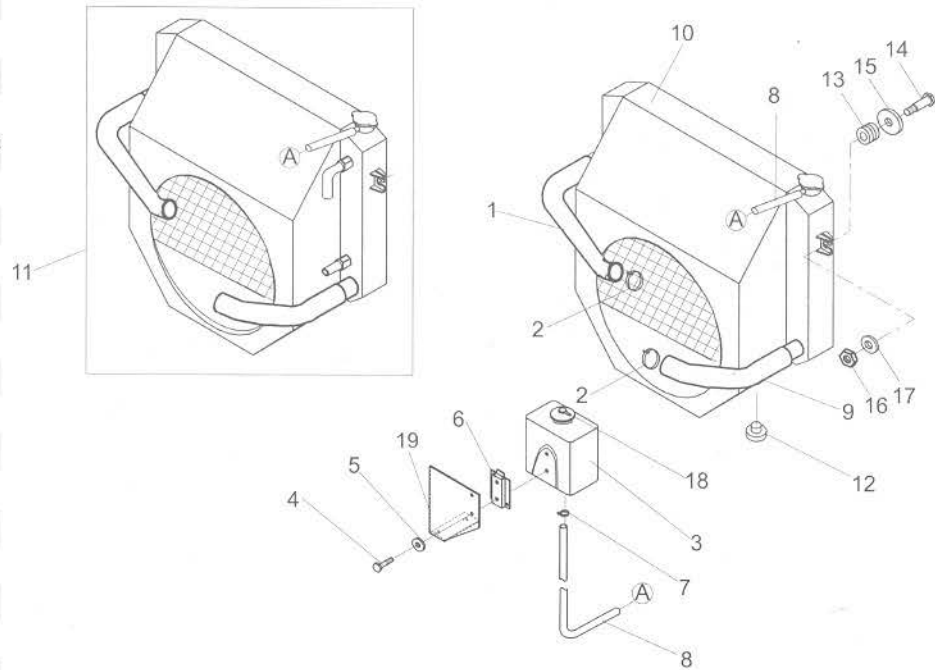

CPC,CPCD20,25,30-X6
CPC,CPCD35-X2

序号 Item No	图号 Part No	零部件名称 Description	件数 Q'ty	备注 Remark
01	HRA91A2101 A91A2-12021	Hose, upper	1	上水管
02	Z4590-00045	Clip	4	双钢丝卡箍 \varnothing 45
03	A91A2-12001	Hose, lower	1	下水管
04	H93C2-12101	Radiator	1	水箱总成 CPC20,25,30,35
05	H93D2-12101	Radiator	1	水箱总成 CPCD20,25,30,35
06	A22A2-12001	Rubber	2	橡胶垫I
07	A22A2-12031	Rubber	2	橡胶垫II
08	A22A2-12041	Bolt	2	螺栓
09	22252-32251	Washer	2	垫片
10	B4016-00008	Nut	2	螺母M8 GB6184-86
11	B5210-00010	Washer	2	垫圈10 GB96-85
12	Z7400-08020	Hose	1	透明胶管 \varnothing 8X200



图19/FIG19

冷却系统(柴油机)/COOLING SYSTEM(DIESEL)

A19

序号 Item No	图号 Part No	零部件名称 Description	件数 Q'ty	备注 Remark
A	HRH99Y2101 H99Y2-10001	Cooling system 冷却系统(配CA498-12)	1	CPC20-35-D
-	HRH99Y2101 H99Z2-10001	Cooling system 冷却系统(配CA498-12)	1	CPCD20-35-D
01	H99Y2-12001	Hose,lower 下水管	1	
02	Z4590-00045	Clip 双钢丝卡箍 \varnothing 45	2	
03	H99Y2-12011	Hose,upper 上水管	1	
04	H99Y2-10201	Radiator 水箱总成	1	CPC20-35-D
-	H99Z2-10201	Radiator 水箱总成	1	CPCD20-35-D
05	A22A2-12001	Rubber 橡胶垫I	2	
06	A22A2-12031	Rubber 橡胶垫II	2	
07	A22A2-12041	Bolt 螺栓	2	
08	22252-32251	Washer 垫片	2	
09	B4016-00008	Nut 螺母M8	2	GB6184-86
10	B5210-00010	Washer 垫圈10	2	GB96-85
11	Z4590-00050	Clip 双钢丝卡箍 \varnothing 50	2	

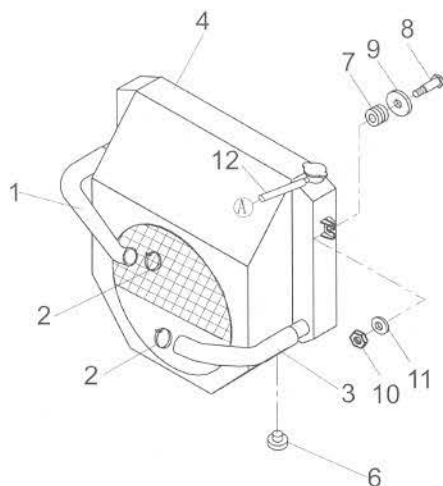
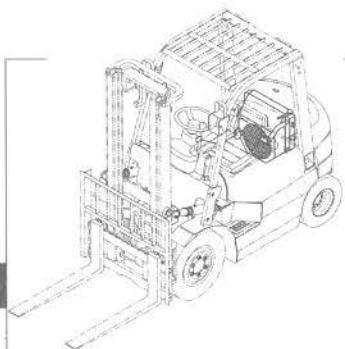
CPC,CPCD20,25,30,35-D

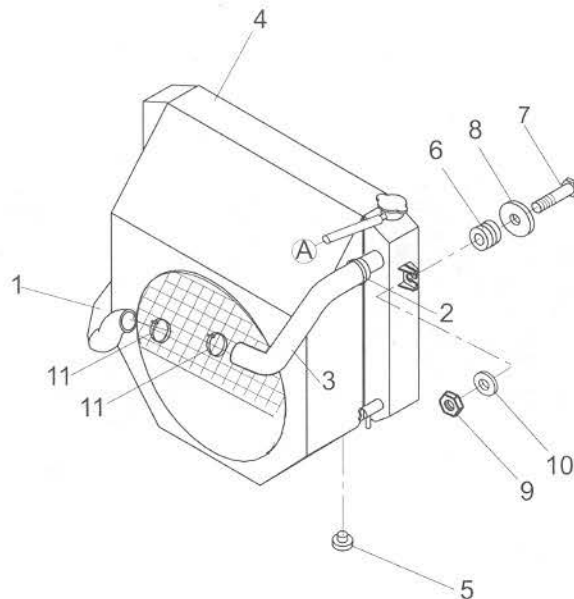
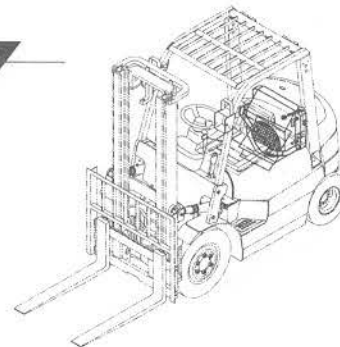

A

CPC,CPCD20,25,30,35-HJ

序号
Item
No图 号
Part No零部件名称
Description件数
Q'ty备 注
Remark

01	H97Y2-12001	Hose, upper	进水管	1	
02	Z4590-00045	Clip	双钢丝卡箍 $\varnothing 45$	4	
03	H97Y2-12011	Hose, lower	出水管	1	
04	H97Y2-10201	Radiator	水箱总成	1	CPC20,25,30
05	H97Z2-10201	Radiator	水箱总成	1	CPCD20,25,30
06	A22A2-12001	Rubber	橡胶垫I	2	
07	A22A2-12031	Rubber	橡胶垫II	2	
08	A22A2-12041	Bolt	螺栓	2	
09	22252-32251	Washer	垫片	2	
10	B4016-00008	Nut	螺母M8	2	GB6184-86
11	B5210-00010	Washer	垫圈10	2	GB96-85



图21/FIG21

燃油系统/FUEL SYSTEM

A21

序号 Item No	图号 Part No	零部件名称 Description	件数 Q'ty	备注 Remark	
A	H24C2-20001	Fuel system	燃油系统	1	
01	23452-22201	Cap	加油盖	1	
02	Z4590-00019	Clip	双钢丝卡箍 $\varnothing 19$	2	
03	Z7300-13032	Tube	胶管 $\varnothing 13 \times 320$	1	
04	Z4590-00065	Clip	双钢丝卡箍 $\varnothing 65$	2	
05	H24C2-22001	Hose	加油胶管	1	
06	B0330-08020	Bolt	螺栓 $M8 \times 20$	2	GB5783-86
07	B5050-00008	Washer	垫圈8	2	GB93-87
08	H24C2-22011	Guard	后挡板	1	
09	22197-52081	Plug, drain	放油螺塞	1	
10	Z6700-03027	Washer	垫圈30	1	JB982-77
11	Z7300-08020	Tube	燃油管 $\varnothing 8 \times 15 \times 200$	1	
12	22512-20152	Nipple	管接头	1	
13	B0330-05012	Bolt	螺栓 $M5 \times 12$	5	GB5783-86
14	B5050-00005	Washer	垫圈5	5	GB93-87
15	23642-20042G	Packing	垫	1	
16	H24C2-22021	Packing	盖板垫	1	
17	H24C2-20102	Plate	盖板总成	1	
18	Z7300-08006	Hose	燃油管 $\varnothing 8 \times 15 \times 60$	1	
19	QD0406	Sedimentor	汽油滤清器	1	
20	Z4710-00012	Clip	钢带型弹性环箍	4	QC/T621-1997
21	B0330-10025	Bolt	螺栓 $M10 \times 25$	8	GB5783-86
22	B5050-00010	Washer, lock	垫圈10	8	GB93-87

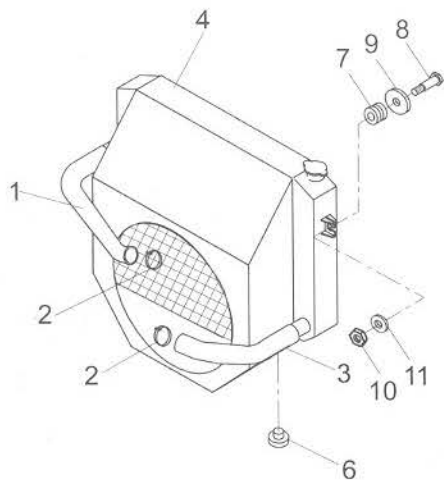
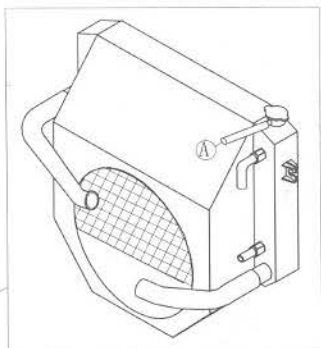
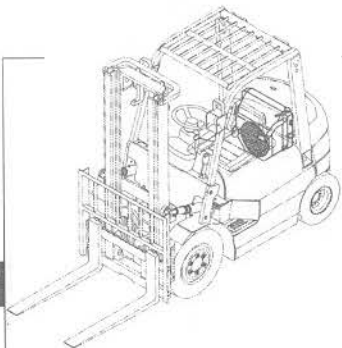
CPQ,CPQD20,25,30-R6
 CPQ,CPQD20H,25H-R11
 CPQ,CPQD30-R12
 CPQ,CPQD35-R3,R4
 CPQ,CPQD20,25,35-ZJ2

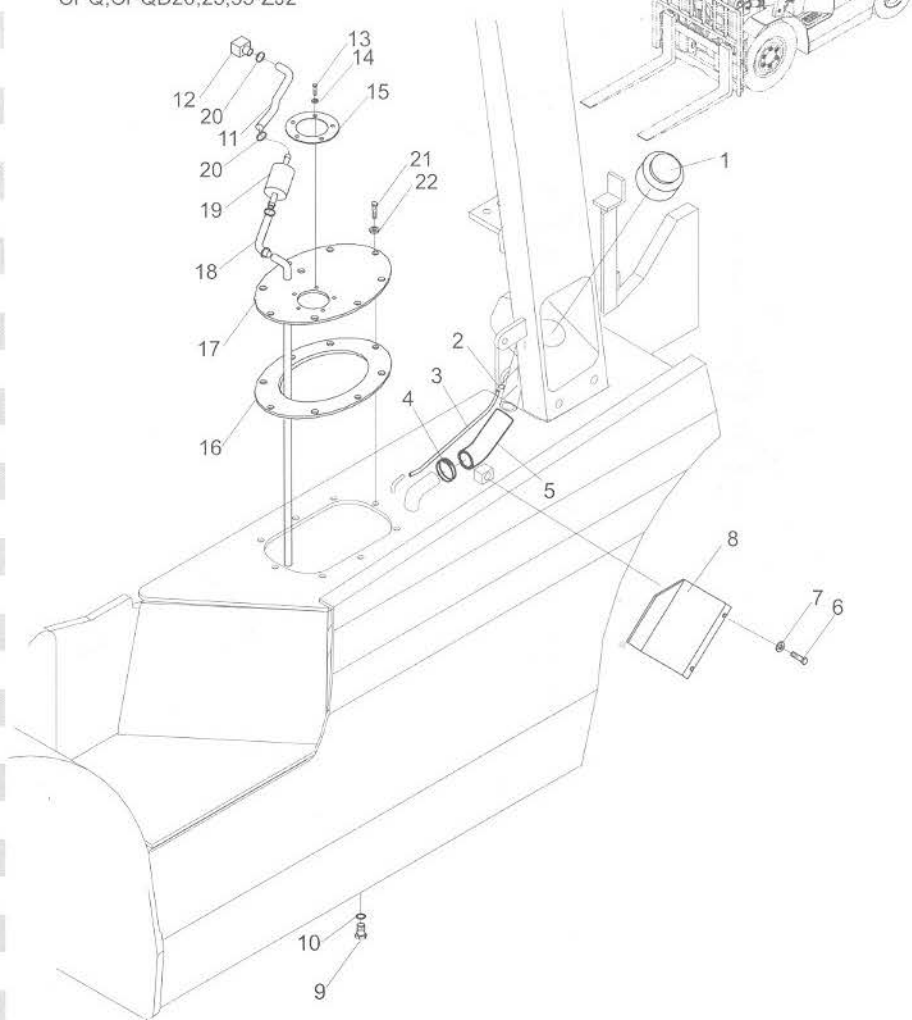

CPQ,CPQD20,25,30,35-ZJ3

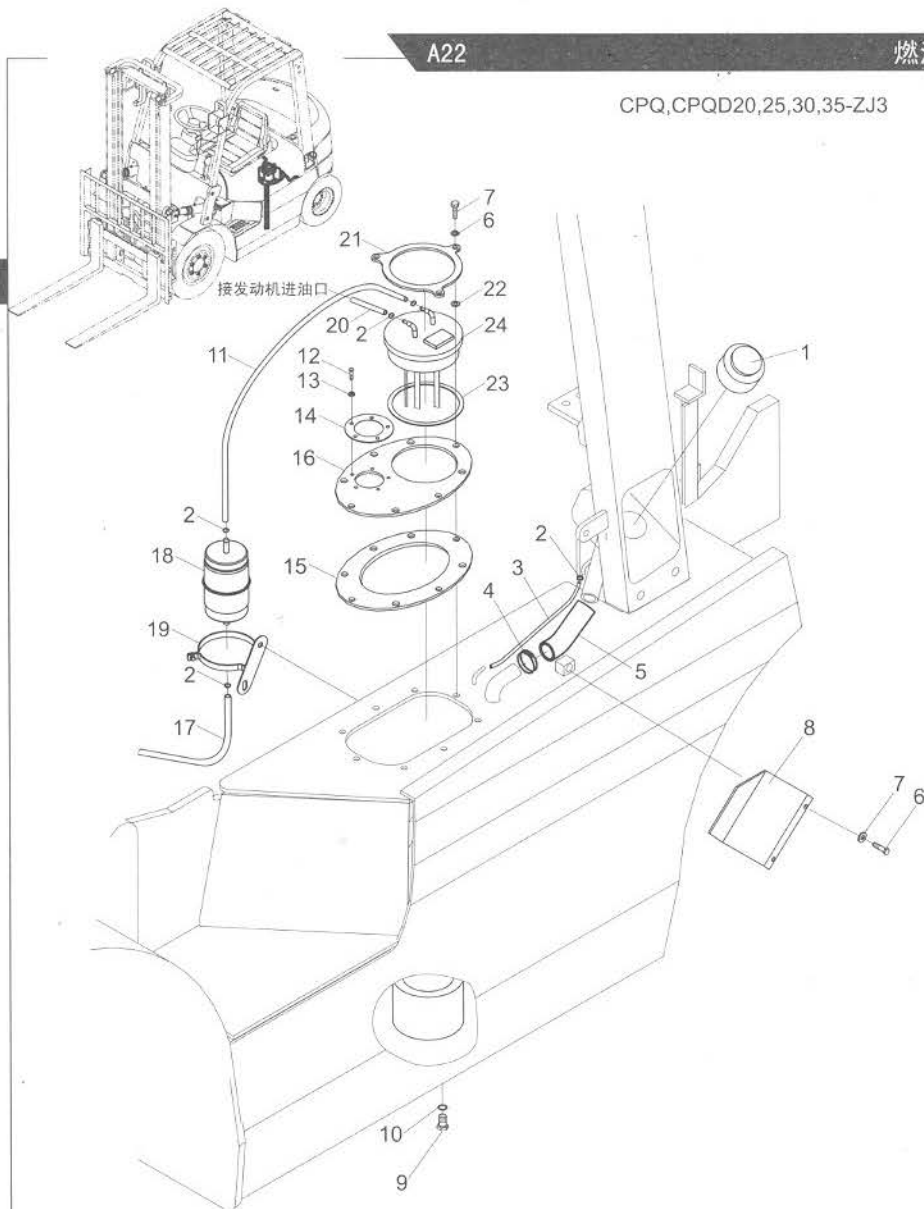

序号 Item No	图号 Part No	零部件名称 Description	件数 Q'ty	备注 Remark	
A	H96N2-20001	Fuel system	燃油系统	1	
01	23452-22201	Cap	加油盖	1	
02	Z4590-00019	Clip	双钢丝卡箍 $\varnothing 19$	6	
03	Z7300-13032	Hose	胶管 $\varnothing 13 \times 320$	1	
04	Z4590-00065	Clip	双钢丝卡箍 $\varnothing 65$	2	
05	H24C2-22001	Hose	加油胶管	1	
06	B0330-08020	Bolt	螺栓M8x20	10	GB5783-86
07	B5050-00008	Washer,lock	垫圈8	10	GB93-87
08	H24C2-22011	Guard	后挡板	1	
09	22197-52081	Plug,drain	放油螺塞	1	
10	Z6700-03027	Washer	组合垫圈30	1	JB982-77
11	Z7300-08025	Hose	燃油管 $\varnothing 8 \times 15 \times 250$	1	
12	B0330-05012	Bolt	螺栓M5x12	5	GB5783-86
13	B5050-00005	Washer,lock	垫圈5	5	GB93-87
14	23642-20042G	Packing	垫	1	
15	H96N2-22021	Packing	盖板垫	1	
16	H96N2-22001	Plate	盖板	1	
17	Z7300-08050	Hose	燃油管 $\varnothing 8 \times 15 \times 500$	1	
18	S1105010ME1	Sedimentor	汽油滤清器	1	
19	491Q-1105011	Bracket	滤清器支架	1	
20	Z7300-08040	Hose	胶管 $\varnothing 8 \times 15 \times 400$	1	
21	H96N2-22011	Plate	油泵盖固定板	1	
22	H96N2-22041	Washer	垫圈	1	
23	H96N2-22031	Packing	燃油泵垫	1	
24	491Q-1104042	Pump	汽油燃油泵	1	

图23/FIG23

燃油系统/FUEL SYSTEM

A23

序号 Item No	图号 Part No	零部件名称 Description	件数 Q'ty	备注 Remark
01	Z3452-22201	Cap 加油盖	1	
02	Z4590-00019	Clip 双钢丝卡箍 $\varnothing 19$	2	
03	Z7300-13032	Tube 胶管 $\varnothing 13 \times 320$	1	
04	Z4590-00065	Clip 双钢丝卡箍 $\varnothing 65$	2	
05	H24C2-22001	Hose 加油胶管	1	
06	B0330-08020	Bolt 螺栓M8X20	4	GB5783-86
07	B5050-00008	Washer,lock 垫圈8	8	GB93-87
08	H24C2-22011	Plate 后挡板	1	
09	Z2197-52081	Plug 放油螺塞	1	
10	Z6700-03027	Washer 垫圈30	1	JB982-77
11	Z7300-08050	Hose 燃油管 $\varnothing 8 \times 13 \times 500$	1	
12	Z4710-00010	Clip 钢带型弹性环箍	8	QC/T621-1997
13	Z7300-08033	Hose 胶管 $\varnothing 8 \times 13 \times 330$	1	
14	Z4662-22031a	Sedimentor 燃油滤清器	1	
15	Z7300-06033	Hose 胶管 $\varnothing 6 \times 13 \times 330$	1	
16	B0330-05012	Bolt 螺栓M5X12	5	GB5783-86
17	B5050-00005	Washer,lock 垫圈5	5	GB93-87
18	Z3642-20042G	Packing 垫	1	
19	H25S2-20102	Cover, tank 盖板总成	1	
20	H24C2-22021	Gasket 盖板垫	1	
21	B0330-08025	Bolt 螺栓M8X25	2	GB5783-86
22	B0330-08025	Bolt 螺栓M8X25	2	GB5783-86
23	HA29C2-20101	Nipple 燃油滤清器接头	2	
24	HA29C2-20112	Bracket 支架	1	
25	H25S2-23011	Sedimentor 柴油滤清器	1	
26	Z7300-08027	Hose 胶管 $\varnothing 8 \times 13 \times 270$	1	
27	B0330-10025	Bolt 螺栓M10X25	8	GB5783-86
28	B5050-00010	Washer,lock 垫圈10	8	GB93-87

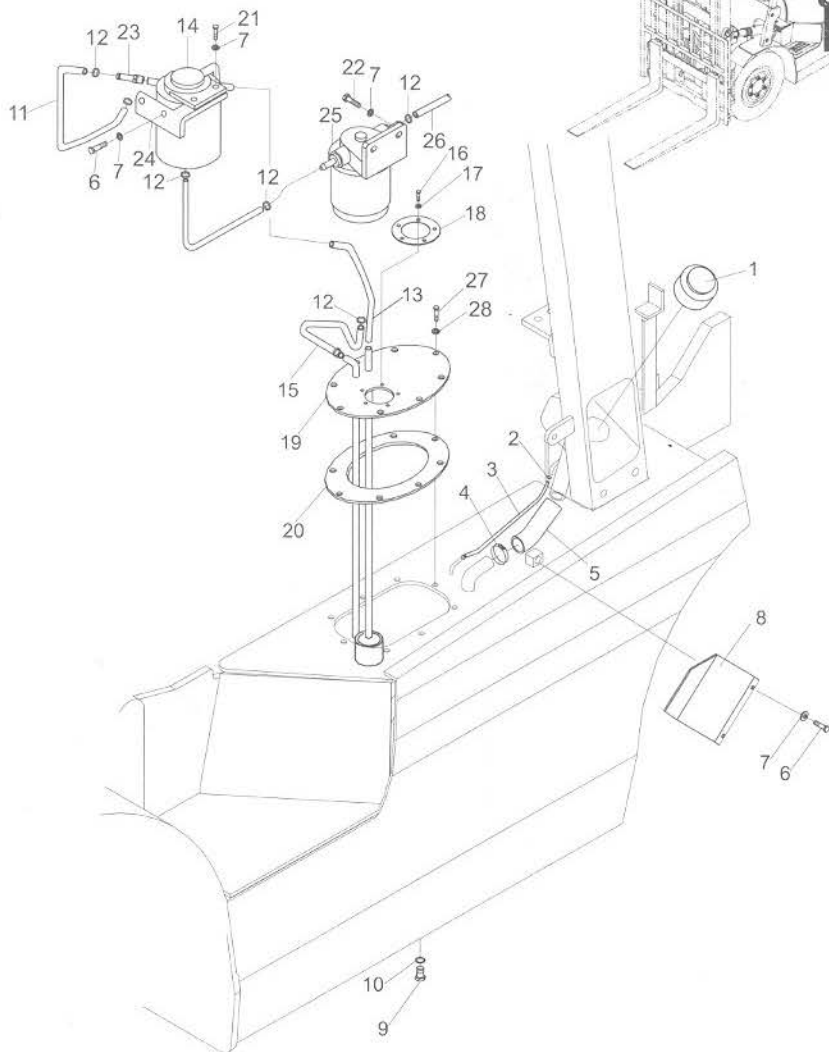
CPC,CPCD20,25,30-W7
CPC,CPCD35-W5

CPC, CPCD20, 25, 30-W8, W9
CPC, CPCD35-W4, W6

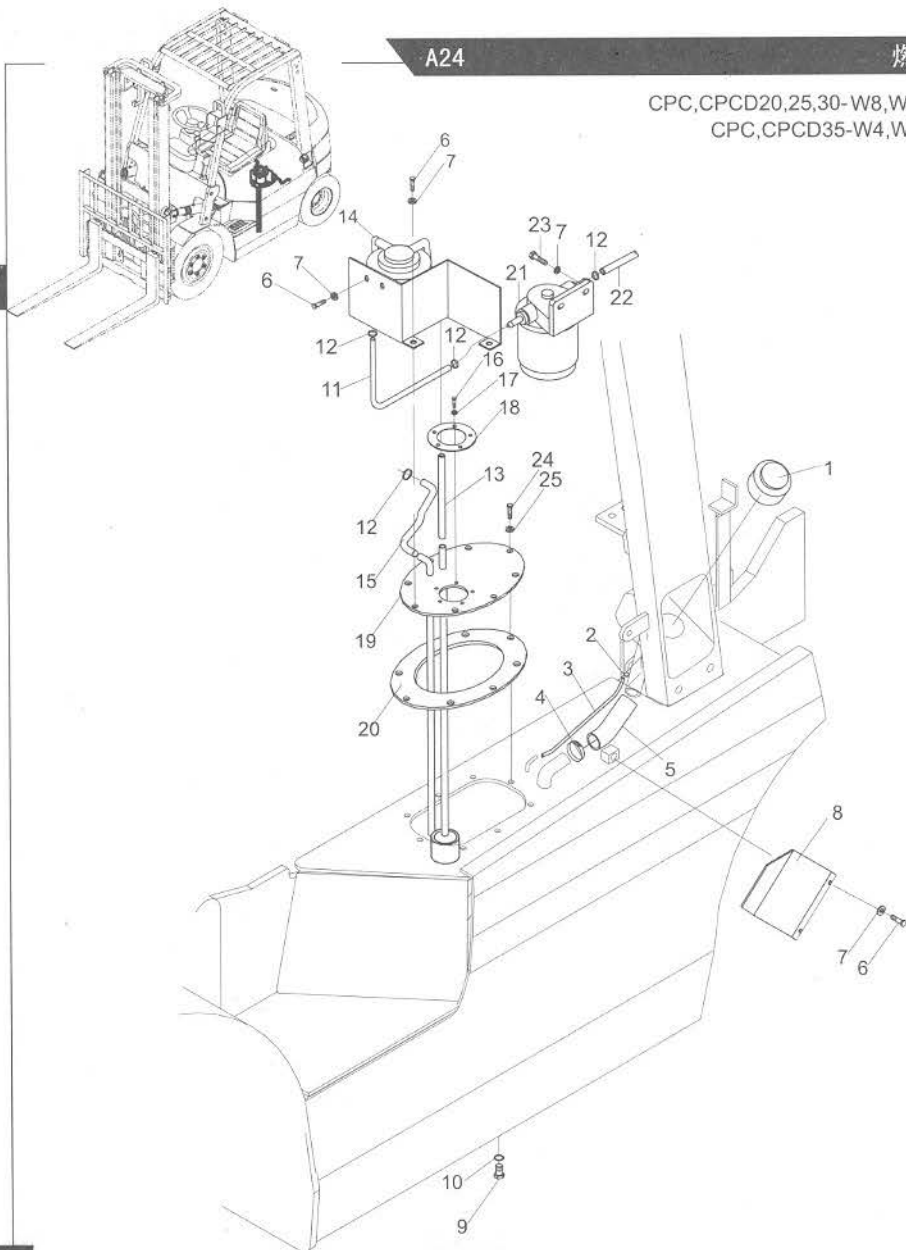

序号 Item No	图号 Part No	零部件名称 Description	件数 Q'ty	备注 Remark
01	23452-22201	Cap	加油盖 1	
02	Z4590-00019	Clip	双钢丝卡箍 \varnothing 19 2	
03	Z7300-13032	Tube	胶管 \varnothing 13X320 1	
04	Z4590-00065	Clip	双钢丝卡箍 \varnothing 65 2	
05	H24C2-22001	Hose	加油胶管 1	
06	B0330-08020	Bolt	螺栓M8X20 4	GB5783-86
07	B5050-00008	Washer	垫圈8 6	GB93-87
08	H24C2-22011	Plate	后挡板 1	
09	22197-52081	Plug	放油螺塞 1	
10	Z6700-03027	Washer	垫圈30 1	JB982-77
11	Z7300-08033	Tube	燃油管 \varnothing 8X13X330 1	
12	Z4710-00010	Clip	钢带型弹性环箍 8	QC/T621-1997
13	Z7300-08019	Tube	胶管 \varnothing 8X13X190 1	CPC(D)20-30-W9 CPC(D)35-W6 HG4-548-67 CPC(D)20-30-W8 CPC(D)35-W4
14	24662-22032	Sedimentor	沉淀分离器 1	
15	Z7300-06033	Tube	胶管 \varnothing 6X13X330 1	
16	B0330-05012	Bolt	螺栓M5X12 5	GB5783-86
17	B5050-00005	Washer	垫圈5 5	GB93-87
18	23642-20042G	Packing	垫 1	
19	H25S2-20102	Cover, tank	盖板总成 1	
20	H24C2-22021	Gasket	盖板垫 1	
21	H25S2-23011	Sedimentor	柴油滤清器 1	
22	Z7300-08027	Hose	胶管 \varnothing 8X13X270 1	HG4-548-67 CPC(D)35-W6 HG4-548-67 CPC(D)20-30-W9
-	Z7300-08055	Hose	胶管 \varnothing 8X13X550 1	HG4-548-67 CPC(D)35-W4 HG4-548-67 CPC(D)20-30-W8
23	B0330-08025	Bolt	螺栓M8X25 2	GB5783-86
24	B0330-10025	Bolt	螺栓M10X25 8	GB5783-86
25	B5050-00010	Washer, lock	垫圈10 8	GB93-87

图25/FIG 25

燃油系统/FUEL SYSTEM

A25

序号 Item No	图号 Part No	零部件名称 Description	件数 Q'ty	备注 Remark
01	23452-22201	Cap 加油盖	1	
02	Z4590-00019	Clip 双钢丝卡箍 \varnothing 19	2	
03	Z7300-13032	Tube 胶管 \varnothing 13X320	1	
04	Z4590-00065	Clip 双钢丝卡箍 \varnothing 65	2	
05	H24C2-22001	Hose 加油胶管	1	
06	B0330-08020	Bolt 螺栓M8X20	4	GB5783-86
07	B5050-00008	Washer 垫圈8	4	GB93-87
08	H24C2-22011	Guard 后挡板	1	
09	22197-52081	Plug, drain 放油螺塞	1	
10	Z6700-03027	Washer 垫圈30	1	JB982-77
11	Z7300-10100	Tube 胶管 \varnothing 10X1000	1	
12	Z4710-00012	Clip 钢带型弹性环箍	8	QC/T621-1997
13	Z7300-10130	Tube 胶管 \varnothing 10X1300	1	
14	B0330-05012	Bolt 螺栓M5X12	5	GB5783-86
15	B5050-00005	Washer 垫圈5	5	GB93-87
16	23642-20042G	Packing 垫	1	
17	H93C2-30502	Plate 盖板总成	1	
18	H24C2-22021	Packing 盖板垫	1	
19	HRA92A2401 22492-42091G	Clip 电瓶正极引线卡	2	CPCD20,25,30,35
-	HRA92A2401 22492-42092G	Clip 电瓶正极引线卡	2	CPC20,25,30,35
20	A22A2-20701	Sedimentor 滤油器	1	
21	H93C2-22081	Bracket 支架	1	
22	DX200MT-0000	Sedimentor 油水分离器	1	
23	Z7300-10060	Hose 胶管 \varnothing 10X600	1	
24	B0330-10025	Bolt 螺栓M10X25	8	GB5783-86
25	B5050-00010	Washer,lock 垫圈10	8	GB93-87

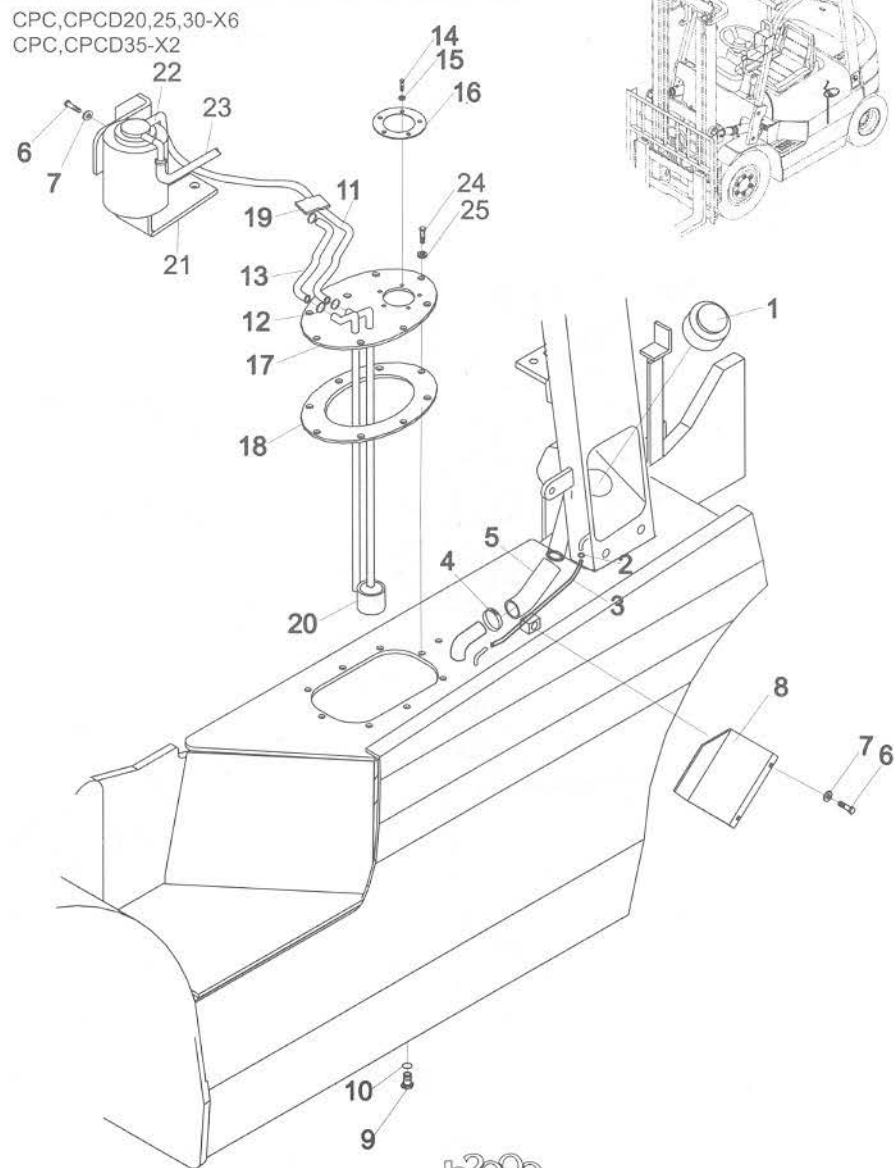

A

CPC,CPCD20,25,30,35-Xs1

序号 Item No	图号 Part No	零部件名称 Description	件数 Q'ty	备注 Remark
A	H21U2-20001	Fuel	燃油系统	
01	23452-22201	Cap	加油盖	
02	Z4590-00019	Clip	双钢丝卡箍 \varnothing 19	
03	Z7300-13032	Tube	胶管 \varnothing 13X320	HG4-548-67
04	Z4590-00065	Clip	双钢丝卡箍 \varnothing 65	
05	H24C2-22001	Hose	加油胶管	
06	B0330-08020	Bolt	螺栓M8X20	GB5783-86
07	B5050-00008	Washer	垫圈8	GB93-87
08	H24C2-22011	Plate	后挡板	
09	22197-52081	Plug	放油螺塞	
10	Z6700-03027	Washer	垫圈30	JB982-77
11	Z7300-08055	Tube	燃油管 \varnothing 8X13X550	HG4-548-67
12	Z4590-00014	Clip	双钢丝卡箍 \varnothing 14	
13	Z7300-08120	Tube	胶管 \varnothing 8X13X1200	HG4-548-67
14	6204-71-7200	Sedimentor	燃油滤清器	
15	Z7300-06120	Tube	胶管 \varnothing 6X13X1200	HG4-548-67
16	B0330-05012	Bolt	螺栓M5X12	GB5783-86
17	B5052-00005	Washer	垫圈5	GB93-87
18	23642-20042G	Packing	垫	
19	H25S2-20102	Cover, tank	盖板总成	
20	H24C2-22021	Gasket	盖板垫	
21	B0330-10025	Bolt	螺栓M10X25	GB5783-86
22	B5050-00010	washer,lock	垫圈10	GB93-87
23	HRA92A2401 22492-42091G	Clip	电瓶正极引线卡	
24	H21U2-22001	Bracket	支架	
25	HRA92A2401 22492-42092G	Clip	电瓶正极引线卡	



图27/FIG27

燃油系统/FUEL SYSTEM

A27

序号 Item No	图号 Part No	零部件名称 Description	件数 Q'ty	备注 Remark
01	Z3452-22201	Cap 加油盖	1	
02	Z4590-00019	Clip 双钢丝卡箍 \varnothing 19	2	
03	Z7300-13032	Tube 胶管 \varnothing 13X320	1	
04	Z4590-00065	Clip 双钢丝卡箍 \varnothing 65	2	
05	H24C2-22001	Hose 加油胶管	1	
06	B0330-08020	Bolt 螺栓M8X20	4	GB5783-86
07	B5050-00008	Washer,lock 垫圈8	6	GB93-87
08	H24C2-22011	Plate 后挡板	1	
09	22197-52081	Plug 放油螺塞	1	
10	Z6700-03027	Washer 垫圈30	1	JB982-77
11	Z7300-08040	Tube 燃油管 \varnothing 8X13X400	1	
12	Z4710-00010	Clip 钢带型弹性环箍	8	QC/T621-1997
13	Z7300-08033	Tube 胶管 \varnothing 8X13X330	1	
14	H99Y2-22901	Sedimentor 柴油水分分离沉淀器	1	
15	Z7300-06110	Tube 胶管 \varnothing 6X13X1100	1	
16	B0330-05012	Bolt 螺栓M5X12	5	GB5783-86
17	B5050-00005	Washer,lock 垫圈5	5	GB93-87
18	23642-20042G	Packing 垫	1	
19	H25S2-20102	Cover, tank 盖板总成	1	
20	H24C2-22021	Gasket 盖板垫	1	
21	H25S2-23011	Sedimentor 柴油滤清器	1	
22	Z7300-08140	Tube 胶管 \varnothing 8X13X1400	1	
23	B0330-08025	Bolt 螺栓M8X25	2	GB5783-86
24	HRA92A2401 22492-42091G	Clip 电瓶正极引线卡	2	CPCD
-	HRA92A2401 22492-42092G	Clip 电瓶正极引线卡	2	CPC
25	B0330-10025	Bolt 螺栓M10X25	8	GB5783-86
26	B5050-00010	Washer,lock 垫圈10	8	GB93-87

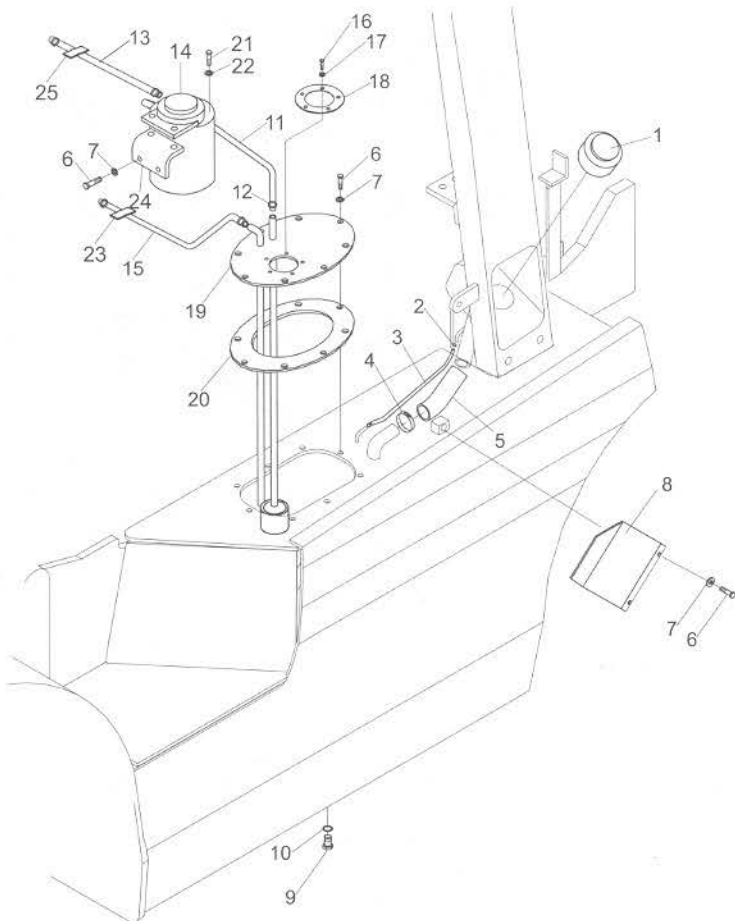
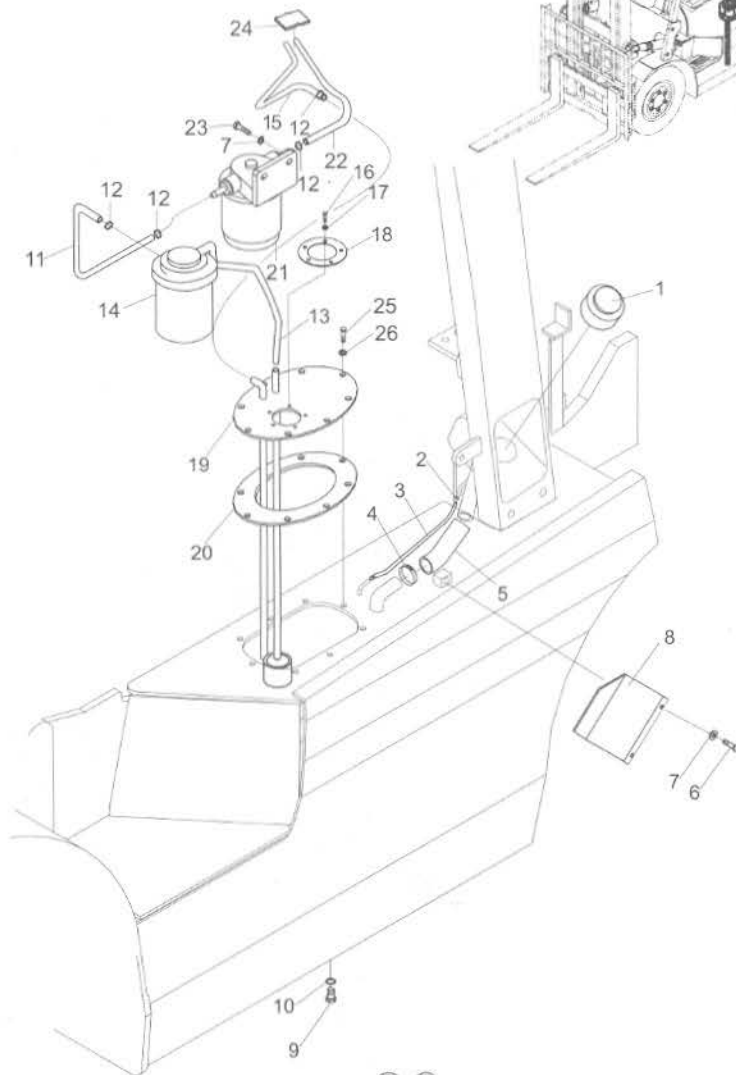
CPC,CPCD20,25,30-HJ
CPC,CPCD35-HJ

CPC,PCPD20,25,30,35-D

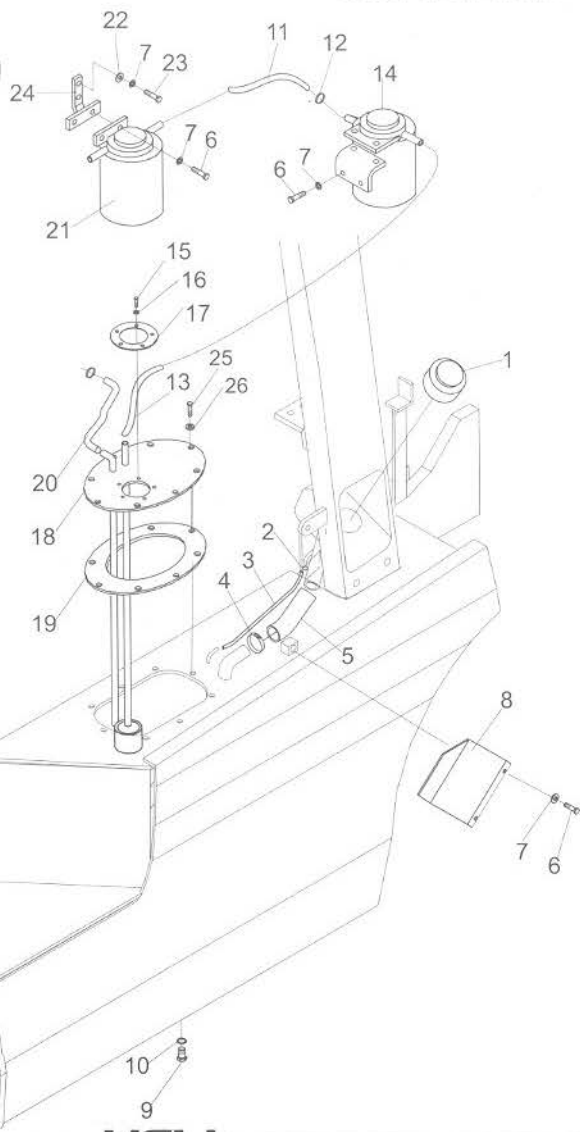

序号 Item No	图号 Part No	零部件名称 Description	件数 Qty	备注 Remark	
A	H99Y2-20001	Fuel system	燃油系统	1	
01	23452-22201	Cap	加油盖	1	
02	Z4590-00019	Clip	双钢丝卡箍 ϕ 19	2	
03	Z7300-13032	Tube	胶管 ϕ 13X320	1	
04	Z4590-00065	Clip	双钢丝卡箍 ϕ 65	2	
05	H24C2-22001	Hose	加油胶管	1	
06	B0330-08020	Bolt	螺栓M8X20	14	GB5783-86
07	B5050-00008	Washer,lock	垫圈8	18	GB93-87
08	H24C2-22011	Guard	后挡板	1	
09	22197-52081	Plug,drain	放油螺塞	1	
10	Z6700-03027	Washer	垫圈30	1	J6982-77
11	Z7300-08073	Tube	胶管 ϕ 8X13X730	1	
12	Z4710-00010	Clip	钢带型弹性环箍	8	QC/T621-1997
13	Z7300-08033	Tube	胶管 ϕ 8X13X330	2	
14	H99Y2-22901	Sedimetry	柴油水分分离沉淀器	1	
15	B0330-05012	Bolt	螺栓M5X12	5	GB5783-86
16	B5050-00005	Washer,lock	垫圈5	5	GB93-87
17	Z3642-20042G	Packing	垫	1	
18	H25S2-20102	Plate	盖板总成	1	
19	H24C2-22021	Packing	盖板垫	1	
20	Z7300-06048	Hose	胶管 ϕ 6X13X480	1	
21	H25S2-23011	Sedimentor	柴油滤清器	1	
22	B0330-08025	Bolt	螺栓M8X25	6	GB5783-86
23	B5111-00008	Washer	垫圈8	4	GB95-85
24	H99Y2-22111	Bracket	滤清器支架	1	
25	B0330-10025	Bolt	螺栓M10X25	8	GB5783-86
26	B5050-00010	Washer,lock	垫圈10	8	GB93-87

图 29/FIG 29

燃油系统/FUEL SYSTEM

A29

序号 Item No	图号 Part No	零部件名称 Description	件数 Q'ty	备注 Remark
A	H2B92-20001	Fuel system 燃油系统	1	
01	23452-22201	Cap 加油盖	1	
02	Z4590-00019	Clip 双钢丝卡箍 $\phi 19$	2	
03	Z7300-13032	Tube 胶管 $\phi 13 \times 320$	1	
04	Z4590-00065	Clip 双钢丝卡箍 $\phi 65$	2	
05	H24C2-22001	Hose 加油胶管	1	
06	B0330-08020	Bolt 螺栓 $M8 \times 20$	6	GB5783-86
07	B5050-00008	Washer,lock 垫圈8	6	GB93-87
08	H24C2-22011	Guard 后挡板	1	
09	22197-52081	Plug,drain 放油螺塞	1	
10	Z6700-03027	Washer 组合垫圈30	1	JB982-77
11	Z7300-08050	Hose 燃油管 $\phi 8 \times 13 \times 500$	1	
12	Z4710-00010	Clip 钢带型弹性环箍	10	QC/T621-1997
13	Z7300-08040	Hose 燃油管 $\phi 8 \times 13 \times 400$	1	
14	H2B92-20201	Sedimentor 燃油滤清器	1	
15	B0330-05012	Bolt 螺栓 $M5 \times 12$	5	GB5783-86
16	B5050-00005	Washer,lock 垫圈5	5	GB93-87
17	23642-20042G	Packing 垫	1	
18	H25S2-20102	Plate 盖板总成	1	
19	H24C2-22021	Packing 盖板垫	1	
20	Z7300-06040	Hose 燃油管 $\phi 6 \times 400$	1	
21	B0330-08025	Bolt 螺栓 $M8 \times 25$	2	GB5783-86
22	B5050-00008	Washer,lock 垫圈8	2	GB93-87
23	B4016-00008	Nut 螺母 $M8$	1	GB6184-86
24	H2B92-20301	Bracket 滤清器支架	1	
25	H2B92-20401	Grease Separator 油水分离器	1	
26	Z7300-08060	Hose 燃油管 $\phi 8 \times 13 \times 600$	1	
27	H2B92-20501	Bracket 油水分离器支架	1	
28	B0330-10025	Bolt 螺栓 $M10 \times 25$	8	GB5783-86
29	B5050-00010	Washer,lock 垫圈10	8	GB93-87
30	B0330-08016	Bolt 螺栓 $M8 \times 16$	4	GB5783-86
31	Z9260-20080	Belt 捆扎带	1	
32	H2B92-22041	Nipple 过渡接头	1	
33	Z7300-04020	Hose 燃油管 $\phi 4 \times 8 \times 200$	1	
34	H2B92-22051	Bracket 安装支架	1	
35	Z7300-04010	Hose 燃油管 $\phi 4 \times 8 \times 100$	2	

CPC,CPCD20,25,30-Ku1

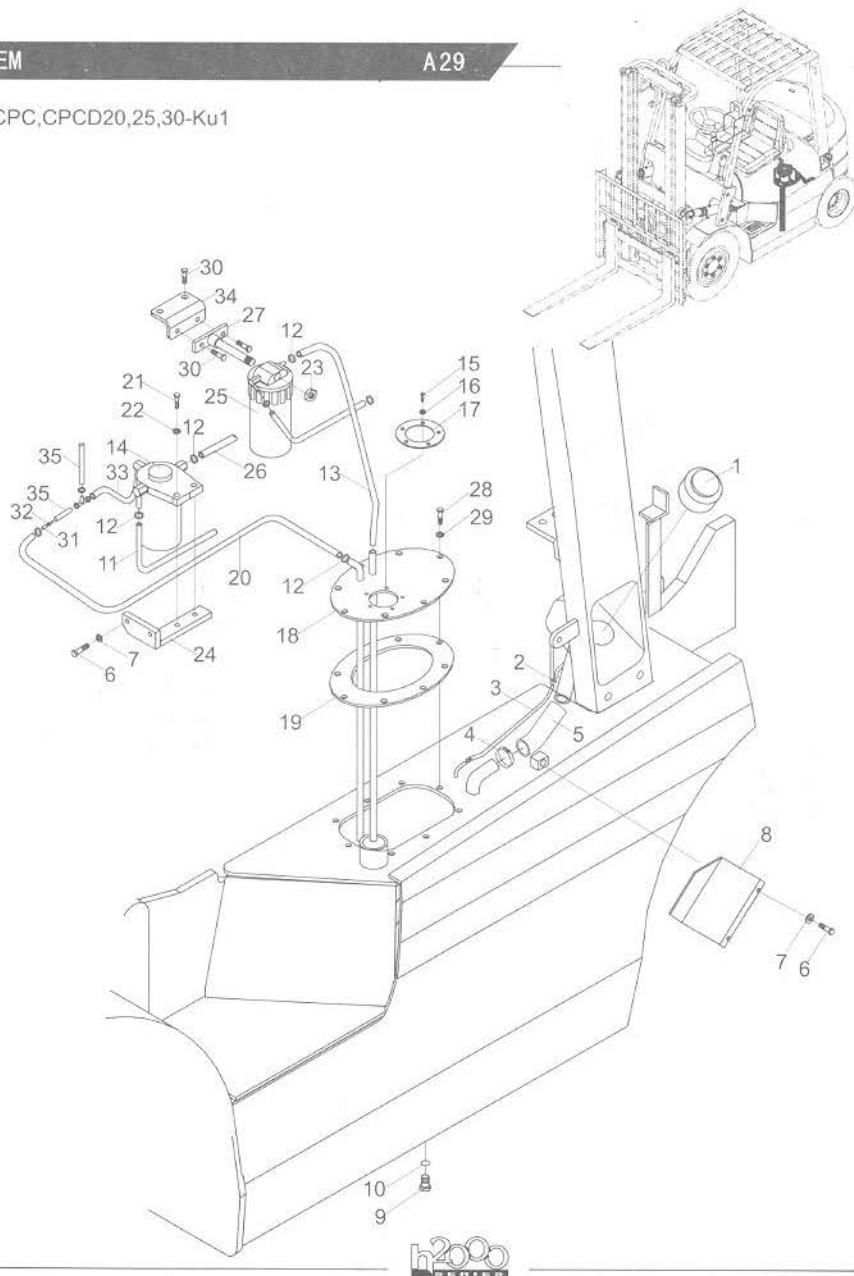

CPC,CPCD20,25,30,35-Xs1

序号 Item No	图号 Part No	零部件名称 Description	件数 Q'ty	备注 Remark	
A	HRH2B12301	Exhaust system	排气系统	1	
01	H21U2-32001	Washer	垫片	1	
02	B4023-00010	Nut	螺母M10	4	GB6184-86
03	B5310-00010	Washer	垫圈10	4	GB97.1-85
04	B5050-00010	Washer,lock	垫圈10	4	GB93-87
05	H2B12-32041	Screw bolt	双头螺栓	4	
06	H2B12-30201	Pipe ass'y	排气管总成	1	
07	H97Y2-32101	U-bolt	U型螺栓	1	
08	22252-32241	Rubber	橡胶垫	4	
09	A22A2-32021	Bolt	螺栓	2	
10	B4023-00008	Nut	螺母M8	2	GB6184-86
11	22252-32251	Washer	垫片	2	
12	B5210-00010	Washer	垫圈10	2	GB96-85
13	H97U2-30201	Muffler	消声器	1	2.2.5t
-	H97Y2-30401	Muffler	消声器	1	3.3.5t
14	H97Y2-32111	U-plate	U型卡板	1	
15	B5050-00008	Washer,lock	垫圈8	2	GB93-87
16	B4116-00008	Nut	螺母M8	2	GB6170-86



图31/FIG31

排气系统/EXHAUST SYSTEM

A31

序号 Item No	图号 Part No	零部件名称 Description	件数 Q'ty	备注 Remark
01	H25S2-32001	Packing 垫片	1	
02	B4213-00010	Nut 螺母M10×1.25	4	GB6173-86
03	B5050-00010	Washer,lock 垫圈10	4	GB93-87
04	H25S2-30201	Pipe ass'y 排气管总成	1	
05	H24C2-32041	Stopper U型卡板	1	
06	22252-32241	Rubber 橡胶垫	4	
07	A22A2-32021	Bolt 螺栓	2	
08	B4016-00008	Nut 螺母M8	2	GB6184-86
09	22252-32251	Shim 垫片	2	
10	B5210-00010	Washer 垫圈10	2	GB96-85
11	H24C2-30401	Muffler 消声器	1	2t,2.5t
-	H24N2-30201	Muffler 消声器	1	3t,3.5t
-	H24C2-30901	Muffler 灭火消声器	1	2t,2.5t
-	H24N2-30901	Muffler 灭火消声器	1	3t,3.5t
-	E24C2-30201	Muffler 净化消声器	1	2t,2.5t
-	E24N2-30201	Muffler 净化消声器	1	3t,3.5t
12	B4116-00008	Nut 螺母M8	2	GB6170-86
13	B5050-00008	Washer,lock 垫圈8	2	GB93-87
14	H24C2-32031	U-bolt U型螺栓	1	

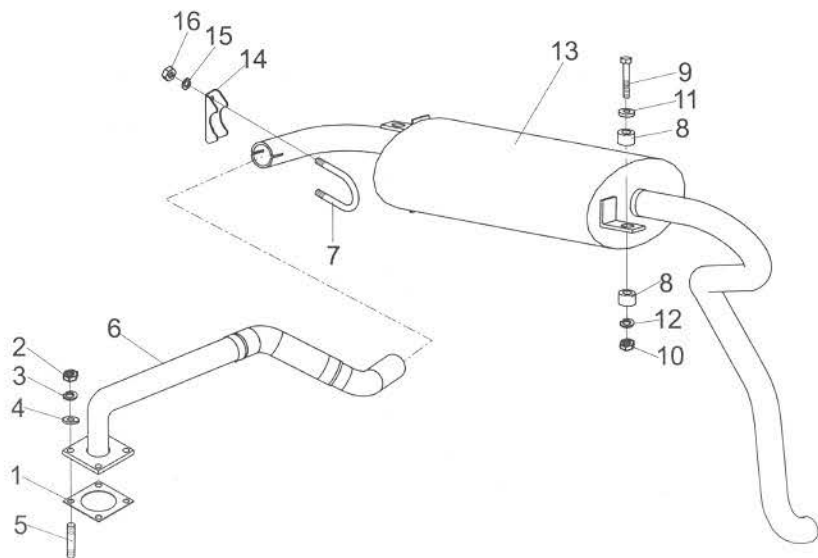
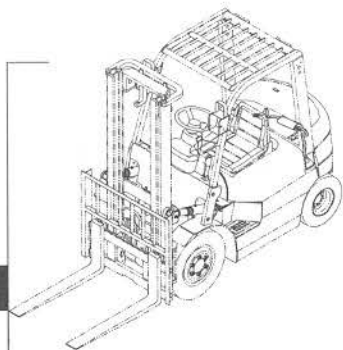
CPC,CPCD20,25,30-W7,W9
CPC,CPCD35-W5,W6

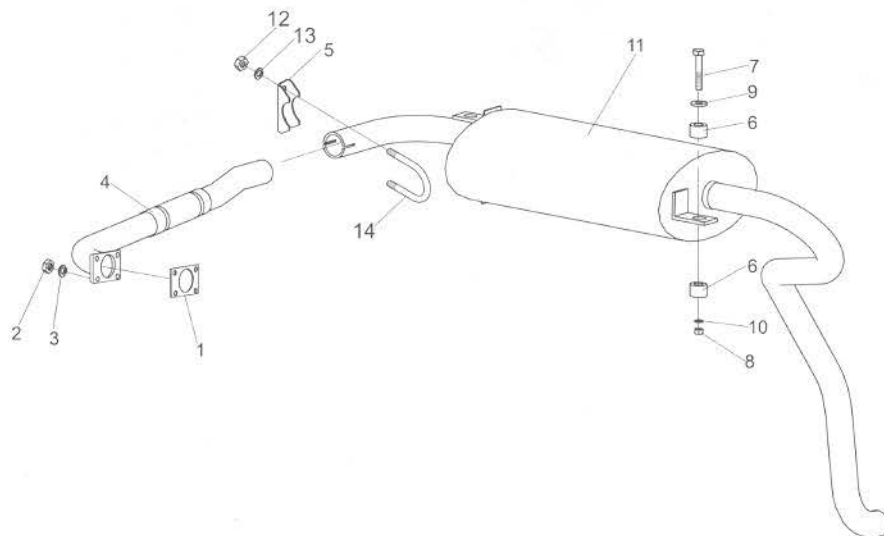
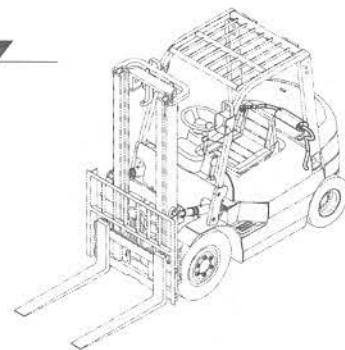

CPQ,CPQD20,25-R6
CPQ,CPQD20H,25H-R11
CPQ,CPQD30-R6,R12
CPQ,CPQD35-R3,R4

序号 Item No	图号 Part No	零部件名称 Description	件数 Q'ty	备注 Remark
01	B4016-00008	Nut	螺母M8	4 GB6184-86
02	B5050-00008	Washer	垫圈8	4 GB93-87
03	H24C2-30201	Pipe ass'y	排气管总成	1
-	H24C2-30501	Pipe ass'y	催化形排气管总成	1 2t,2.5t选用
04	H24C2-32041	Stopper	U型卡板	1
05	22252-32241	Rubber	橡胶垫	4
06	A22A2-32021	Bolt	螺栓	2
07	H24C2-32031	U-bolt	U型螺栓	1
08	22252-32251	Shim	垫片	2
09	B5310-00008	Washer	垫圈8	2 GB97.1-85 2t,2.5t
-	B5310-00010	Washer	垫圈10	2 GB97.1-85 3t,3.5t
10	H24C2-30401	Muffler	消声器	1
-	H24N2-30201	Muffler	消声器	1
-	H24C2-30901	Muffler	灭火消声器	1 2t,2.5t选用
-	H24N2-30901	Muffler	灭火消声器	1 3t,3.5t选用
11	B4116-00008	Nut	螺母M8	2 GB6170-86



图33/FIG33

排气系统/EXHAUST SYSTEM

A33

序号 Item No	图号 Part No	零部件名称 Description	件数 Qty	备注 Remark
01	20062-30200G	Packing	垫片	1
02	B4016-00008	Nut	螺母M8	2 GB6184-86
03	B5210-00008	Washer,lock	垫圈8	2 GB96-85
04	H93C2-30202	Pipe ass'y	排气管总成	1
05	H24C2-32041	Stopper	U型卡板	1
06	22252-32241	Rubber	橡胶垫	4
07	A22A2-32021	Bolt	螺栓	2
08	B4016-00008	Nut	螺母M8	2 GB6184-86
09	22252-32251	Shim	垫片	2
10	B5210-00010	Washer	垫圈10	2 GB96-85
11	H27C2-30201	Muffler	消声器	1 2t,2.5t
-	H25N2-30401	Muffler	消声器	1 3t,3.5t
-	H93C2-30901	Muffler	灭火消声器	1 2t,2.5t
-	H93N2-30901	Muffler	灭火消声器	1 3t,3.5t
-	E25N2-30401	Muffler	净化消声器	1 3t,3.5t
12	B4116-00008	Nut	螺母M8	2 GB6170-86
13	B5050-00008	Washer,lock	垫圈8	2 GB93-87
14	H24C2-32031	U-bolt	U型螺栓	1

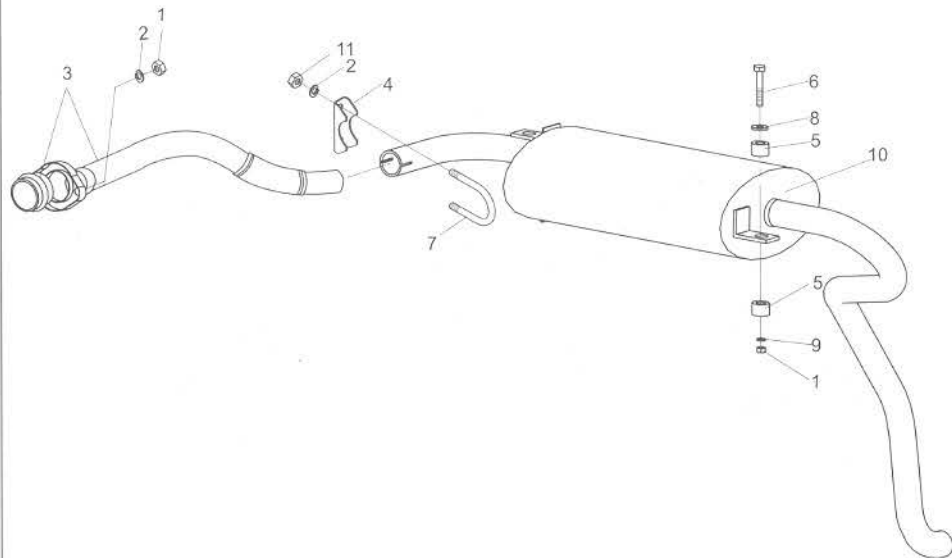
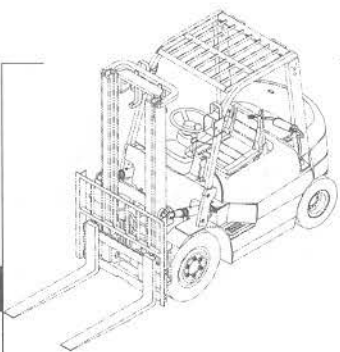
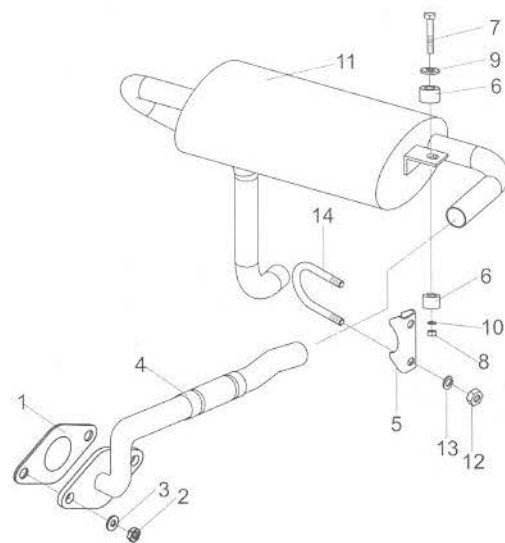
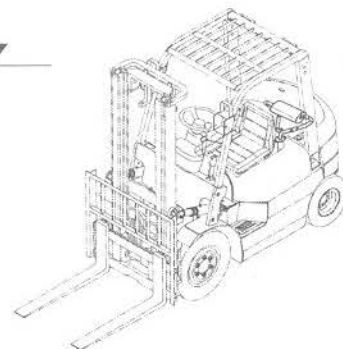
CPC,CPCD20,25,30-X6
CPC,CPCD35-X2

A

CPC,CPCD20,25,30-W8
CPC,CPCD35-W4

序号 Item No	图号 Part No	零部件名称 Description	件数 Qty	备注 Remark
01	H25N2-32001	Packing	垫片 1	
02	B4016-00008	Nut	螺母M8 2	GB6184-86
03	B5050-00008	Washer,lock	垫圈8 4	GB93-87
04	H25N2-30201	Pipe ass'y	排气管总成 1	
05	H24C2-32041	Stopper	U型卡板 1	
06	22252-32241	Rubber	橡胶垫 4	
07	A22A2-32021	Bolt	螺栓 2	
08	B4016-00008	Nut	螺母M8 2	GB6184-86
09	22252-32251	Shim	垫片 2	
10	B5210-00010	Washer	垫圈10 2	GB96-85
11	H27C2-30201	Muffler	消声器 1	2t,2.5t
-	H25N2-30401	Muffler	消声器 1	3t,3.5t
-	H93C2-30901	Muffler	灭火消声器 1	2t,2.5t
-	H93N2-30901	Muffler	灭火消声器 1	3t,3.5t
-	E25N2-30401	Muffler	净化消声器 1	3t,3.5t
12	B4116-00008	Nut	螺母M8 2	GB6170-86
13	H24C2-32031	U-bolt	U型螺栓 1	



图35/FIG35

排气系统/EXHAUST SYSTEM

A35

CPC, CPCD20, 25, 30, 35-D

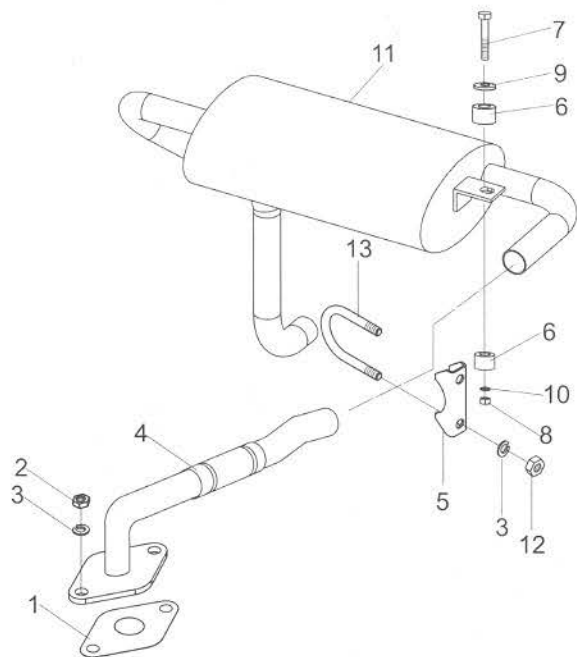
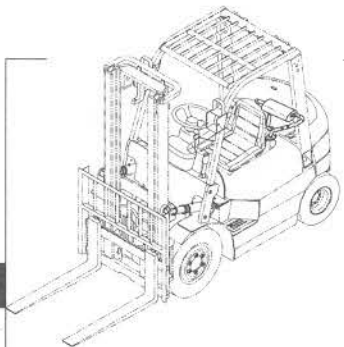
序号 Item No	图号 Part No	零部件名称 Description	件数 Q'ty	备注 Remark	
A	H99Y2-30001	Exhaust system	排气系统	1	3t, 3.5t
-	H99U2-30001	Exhaust system	排气系统	1	2t, 2.5t
01	H99Y2-32001	Flange packing	法兰垫	1	
02	B0110-08025	Bolt	螺栓M8X25	4	GB5781-86
03	B5050-00008	Washer, lock	垫圈8	4	GB93-87
04	H99Y2-30201	Pipe ass'y	排气管总成	1	
05	H99Y2-30301	Muffler	消声器	1	3t, 3.5t
-	H99U2-30201	Muffler	消声器	1	2t, 2.5t
-	H99Y2-30401	Muffler	灭火消声器	1	3t, 3.5t
-	H99U2-30301	Muffler	灭火消声器	1	2t, 2.5t
06	22252-32241	Rubber	橡胶垫	4	
07	A22A2-32021	Bolt	螺栓	2	
08	B4617-00008	Nut	螺母M8	2	GB6184-86
09	22252-32251	Washer	垫片	2	
10	B5310-00010	Washer	垫圈10	2	GB97.1-85
11	H97Y2-32101	U-bolt	U型螺栓	1	
12	H97Y2-32111	U-plate	U型卡板	1	
13	B5050-00008	Washer, lock	垫圈8	2	GB93-87
14	B4116-00008	Nut	螺母M8	2	GB6170-86
15	H99Y2-32181	Barrier packing	隔热垫板	1	

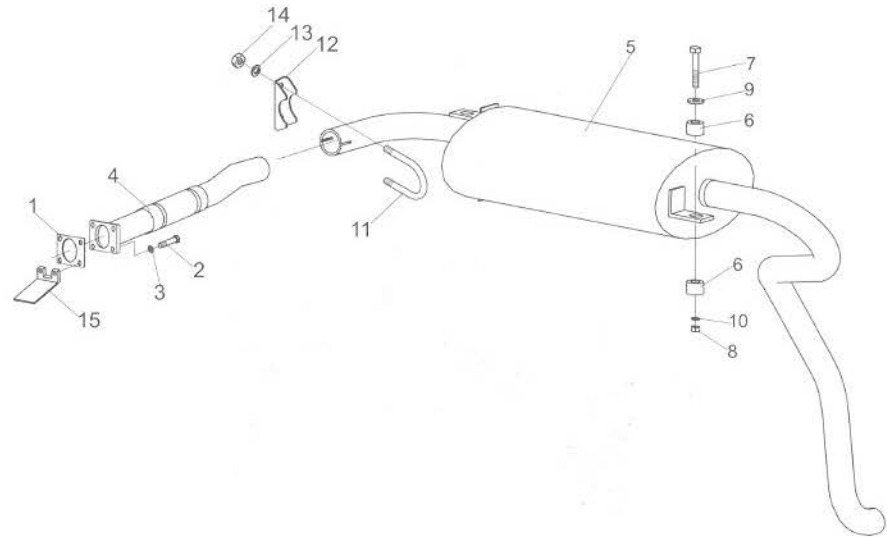
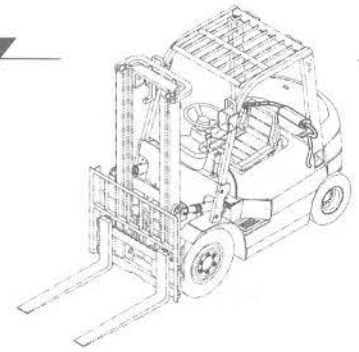

A

CPC,CPCD20,25,30,35-HJ

序号
Item
No图号
Part No零部件名称
Description件数
Q'ty备注
Remark

01	H97Y2-32001	Packing	法兰垫	1	
02	B0110-08025	Bolt	螺栓M8X25	4	GB5781-86
03	B5050-00008	Washer,lock	垫圈8	6	GB93-87
04	H97Y2-32021	Pipe ass'y	排气管总成	1	
05	H97Y2-32111	Stopper	U型卡板	1	
06	22252-32241	Rubber	橡胶垫	4	
07	A22A2-32021	Bolt	螺栓	2	
08	B4016-00008	Nut	螺母M8	2	GB6184-86
09	22252-32251	Shim	垫片	2	
10	B5210-00010	Washer	垫圈10	2	GB96-85
11	H97U2-30201	Muffler	消声器	1	2t,2.5t
-	H97Y2-30401	Muffler	消声器	1	3t,3.5t
-	HRH97Y2301	Muffler	灭火消声器	1	2t,2.5t
-	H97U2-32011	Muffler	灭火消声器	1	2t,2.5t
-	HRH97Y2301	Muffler	灭火消声器	1	3t,3.5t
-	H97Y2-30501	Muffler	净化消声器	1	2t,2.5t
-	E97U2-30201	Muffler	净化消声器	1	2t,2.5t
-	E97Y2-30401	Muffler	净化消声器	1	3t,3.5t
12	B4116-00008	Nut	螺母M8	2	GB6170-86
13	H97Y2-32101	U-bolt	U型螺栓	1	



图37/FIG37

排气系统/EXHAUST SYSTEM

A37

序号 Item No	图号 Part No	零部件名称 Description	件数 Q'ty	备注 Remark
01	H94N2-32041	Shim	接头垫片	1
02	B5050-00008	Washer	垫圈8	4 GB93-87
03	H98N2-30101	Pipe	排气管1	1
04	H24C2-32041	Stopper	U型卡板	2
05	22252-32241	Rubber	橡胶垫	4
06	A22A2-32021	Bolt	螺栓	2
07	B4016-00008	Nut	螺母M8	2 GB6184-86
08	22252-32251	Shim	垫片	2
09	B5310-00010	Washer	垫圈10	2 GB97.1-85
10	H24C2-30401	Muffler	消声器	1 2t,2.5t
-	H24N2-30201	Muffler	消声器	1 3t
11	B4116-00008	Nut	螺母M8	4 GB6170-86
12	H24C2-32031	U-bolt	U型螺栓	2
13	H98N2-30301	Pipe	排气管B	1
14	H94N2-32081	Sleeve	隔热套	1

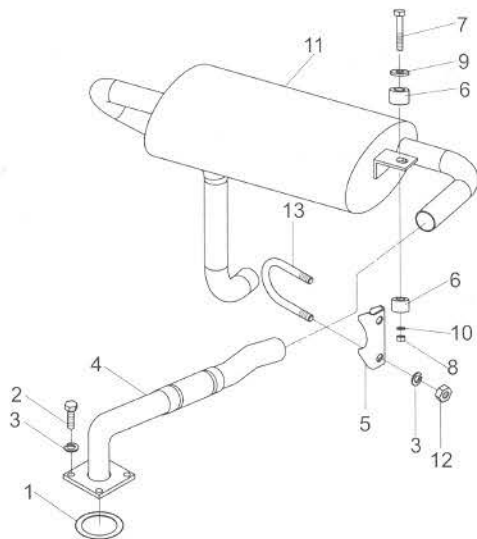
CPQ,CPQD20,25,30,35-ZJ2

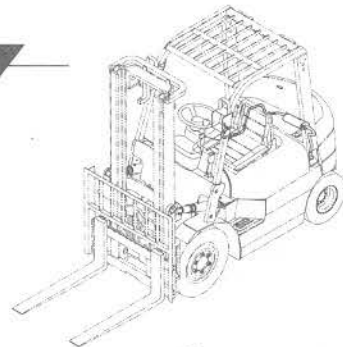
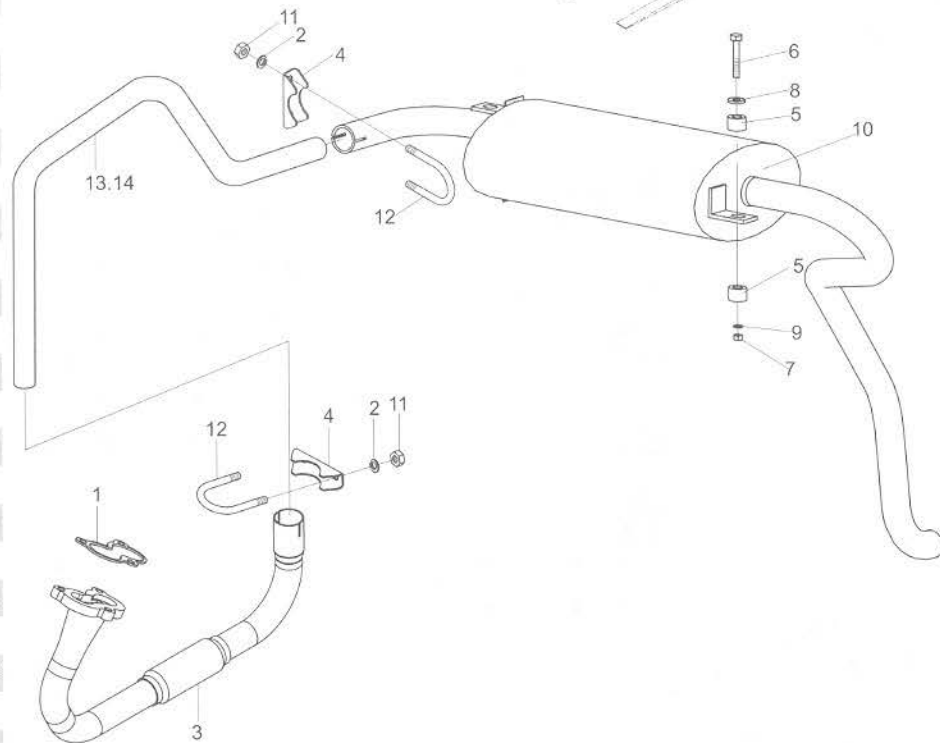

A

CPQ,CPQD20,25,30,35-ZJ3

序号 Item No	图号 Part No	零部件名称 Description	件数 Q'ty	备注 Remark
A	H96C2-30001	Exhaust system	1	排气系统 2t,2.5t
-	H96N2-30001	Exhaust system	1	排气系统 3t,3.5t
01	H96N2-30201	Muffler	1	催化净化消声器
02	H96N2-30301	Pipe ass'y,back	1	后排气管总成
03	H2YY2-30411	Packing	2	排气管垫片
04	H96N2-30101	Pipe ass'y,front	1	前排气管总成
05	B0330-10035	Bolt	4	螺栓M10x35 GB5783-86
06	B4116-00010	Nut	4	螺母M10 GB6170-86
07	B5310-00010	Washer	4	垫圈10 GB97.1-85
08	B5050-00010	Washer	7	垫圈10 GB93-87
09	H24C2-32031	Bolt	1	U型螺栓
10	H2YW2-32001	Pipe	1	尾管 2t,2.5t
-	H2YY2-32121	Pipe	1	尾管 3t,3.5t
11	B0530-10030	Bolt	3	螺栓M10x1.25x30 GB5786-86
12	H96N2-32151	Oxygen sensor	1	氧传感器
13	22252-32241	Rubber	4	橡胶垫
14	22252-32251	Shim	2	垫片
15	A22A2-32021	Bolt	2	螺栓
16	B5210-00008	Washer	2	垫圈8 GB96-85
17	B4016-00008	Nut	2	螺母M8 GB6184-86
18	H24C2-32041	Clip	1	U型卡板
19	B5050-00008	Washer	2	垫圈8 GB93-87
20	B4116-00008	Nut	2	螺母M8 GB6170-86



图39/FIG39

排气系统/EXHAUST SYSTEM

A39

序号 Item No	图号 Part No	零部件名称 Description	件数 Q'ty	备注 Remark
A	HRH2B12301	Exhaust system	排气系统	1
01	H21U2-32001	Washer	垫片	1
02	B4023-00010	Nut	螺母M10	4 GB6184-86
03	B5310-00010	Washer	垫圈10	4 GB97.1-85
04	B5050-00010	Washer,lock	垫圈10	4 GB93-87
05	H2B12-32041	Screw bolt	双头螺柱	4
06	H2B12-30201	Pipe ass'y	排气管总成	1
07	H97Y2-32101	U-bolt	U型螺栓	1
08	22252-32241	Rubber	橡胶垫	4
09	A22A2-32021	Bolt	螺栓	2
10	B4023-00008	Nut	螺母M8	2 GB6184-86
11	22252-32251	Washer	垫片	2
12	B5210-00010	Washer	垫圈10	2 GB96-85
13	H97U2-30201	Muffler	消声器	1 2.2.5t
-	H97Y2-30401	Muffler	消声器	1 3.3.5t
-	E97U2-30201	Muffler	净化消声器	1 2.2.5t
-	E97Y2-30401	Muffler	净化消声器	1 3.3.5t
14	H97Y2-32111	U-plate	U型卡板	1
15	B5050-00008	Washer,lock	垫圈8	2 GB93-87
16	B4116-00008	Nut	螺母M8	2 GB6170-86

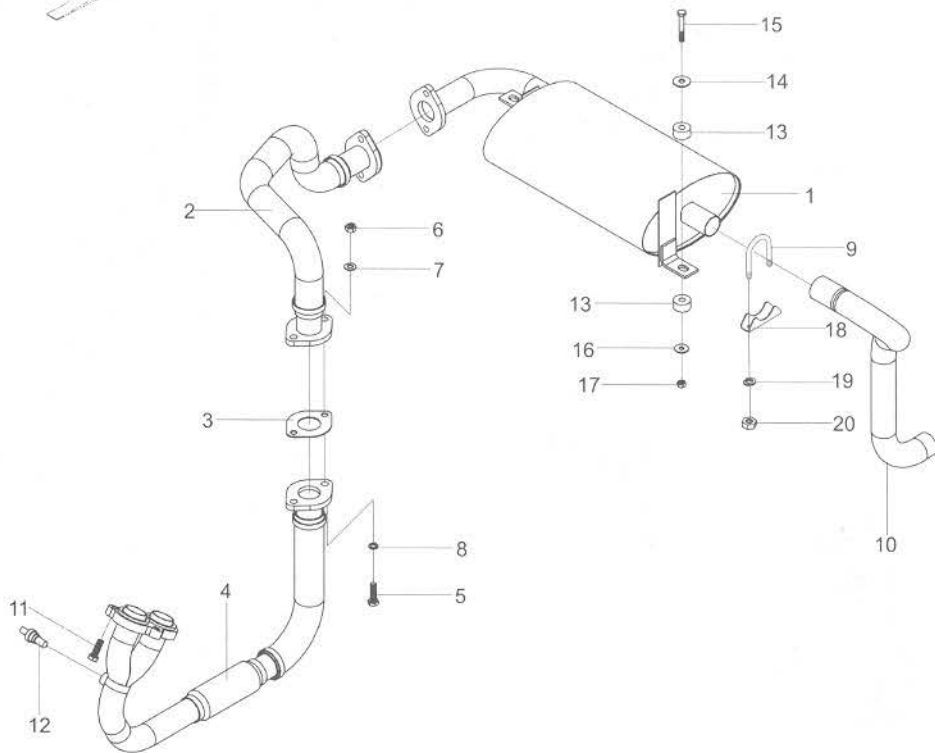
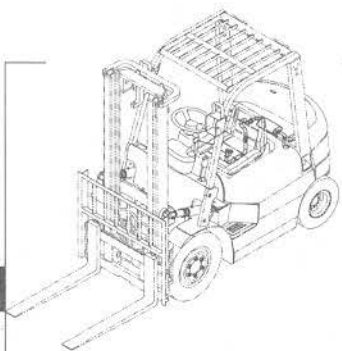
CPC,CPCD20,25,30,35- Xs1

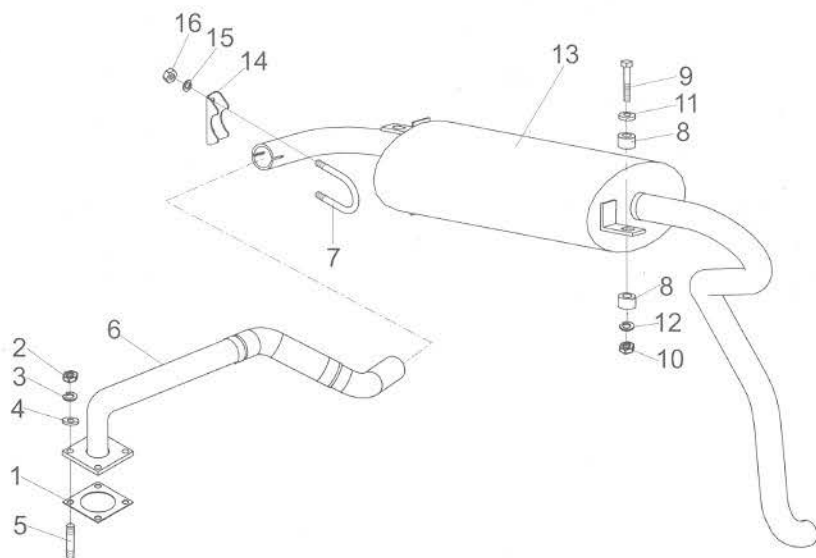
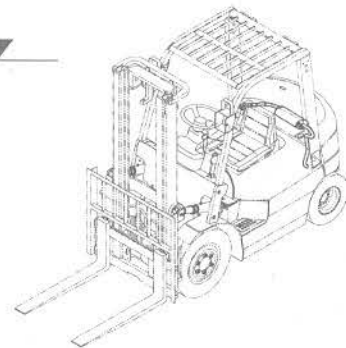

A

CPC,CPCD20,25,30-Ku1

序号
Item
No图号
Part No零部件名称
Description件数
Q'ty备注
Remark

序号 Item No	图号 Part No	零部件名称 Description		件数 Q'ty	备注 Remark
A	HRH2B92301 H2B92-30001	Exhaust system	排气系统	1	2t,2.5t
-	HRH2B92301 H2F92-30001	Exhaust system	排气系统	1	3t
01	22252-32241	Rubber	橡胶垫	4	
02	22252-32251	Washer	垫片	2	
03	A22A2-32021	Bolt	螺栓	2	
04	B4023-00008	Nut	螺母M8	2	GB6184-86
05	B4223-00010	Nut	螺母M10x1.25	2	GB6171-86
06	B5050-00010	Washer,lock	垫圈10	2	GB93-87
07	B5310-00010	Washer	垫圈10	2	GB97.1-85
08	H2B92-30301	MuffLer	消声器	1	2t,2.5t
-	H2F92-30201	MuffLer	消声器	1	3t
09	H2B92-30201	Pipe ass'y	排气管总成	1	
10	H97Y2-32101	U-bolt	U型螺栓	1	
11	H97Y2-32111	U-plate	U型卡板	1	
12	B5050-00008	Washer,lock	垫圈8	2	GB93-87
13	B4116-00008	Nut	螺母M8	2	GB6170-86



图41/FIG41

电气系统/ELECTRIC SYSTEM

B1

序号 Item No	图号 Part No	零部件名称 Description	件数 Qty	备注 Remark
01	H24C2-40213	Cabinet harness 仪表架线束	1	机械或液力变速箱
02	H25S2-40412	Cabinet harness 仪表架线束	1	电液控制变速箱
03	H24C2-40223	Engine harness 发动机线束	1	机械或液力变速箱
04	H24C2-40422	Engine harness 发动机线束	1	电液控制变速箱
05	H24C2-40231	Rear head guard harness 后护顶架线束	2	
06	Z8498-ZB103S	Combination M/T H2000型组合仪表	1	See Fig.50
07	H24C2-40521	Combination M/T H2001型组合仪表	1	See Fig.51
08	A22A2-40800	Shuck 上壳	1	
09	A22A2-40810	Shuck 下壳	1	
10	A22A2-40820	Cover 后盖	1	
11	H24C2-40601	Control box 控制盒	1	电液控制变速箱
12	A73J2-41302	Switch,direction 方向开关	1	电液控制变速箱
13	JQ1030/04	Relay 启动继电器	1	
14	D06BX2081	Fuse box 保险丝盒	1	
15	Z9260-30100	Belt clip 捆扎带3X100	12	
16	Z9260-40200	Belt clip 捆扎带4X200	8	
17	Z9260-48350	Belt clip 捆扎带4.8X350	2	
18	H24C2-42131	Belt clip 固定可开式锁式扎带	14	
19	HRH24C2404	Rubber ring 出线胶圈	6	
20	H24C2-40701	Rubber ring 防尘胶圈	2	
21	H24C2-40431	Cable,caution light 警示灯线束	1	选用
22	H24C2-40491	Caution light 警示灯	1	选用
23	D0444001	Water temp sending unit 水温传感器	1	发动机附
24	Z8510-120DZ	Back buzzer 倒车蜂鸣器	1	DJB-12B
25	B1010-06016	Bolt 螺钉M6X16	1	GB65-85
26	B5050-00006	Washer,lock 垫圈	1	GB93-87
27	A22A2-40400	Cable 电瓶引线(-)	1	
28	D016-QW-60	Battery 蓄电池	1	6-QW-60
29	A22A2-40410	Cable 电瓶引线(+)	1	
30	22492-42091G	Cable clip 电瓶引线卡	2	

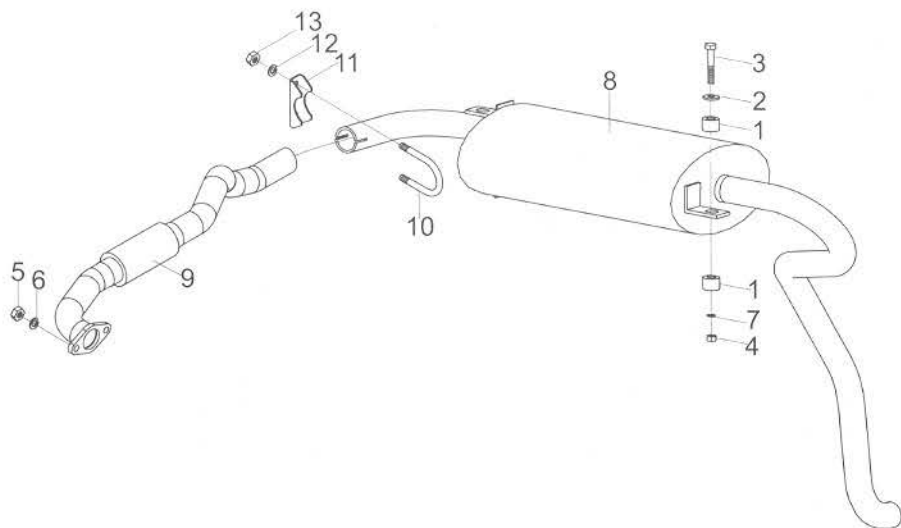
CPQ,CPQD20,25,30-R6
 CPQ,CPQD20H,25H-R11
 CPQ,CPQD30-R12
 CPQ,CPQD35-R3,R4

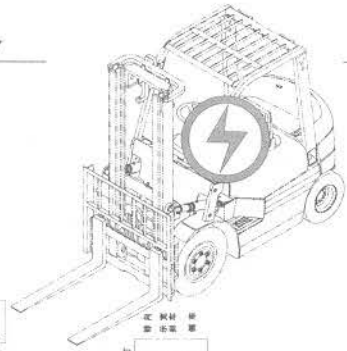
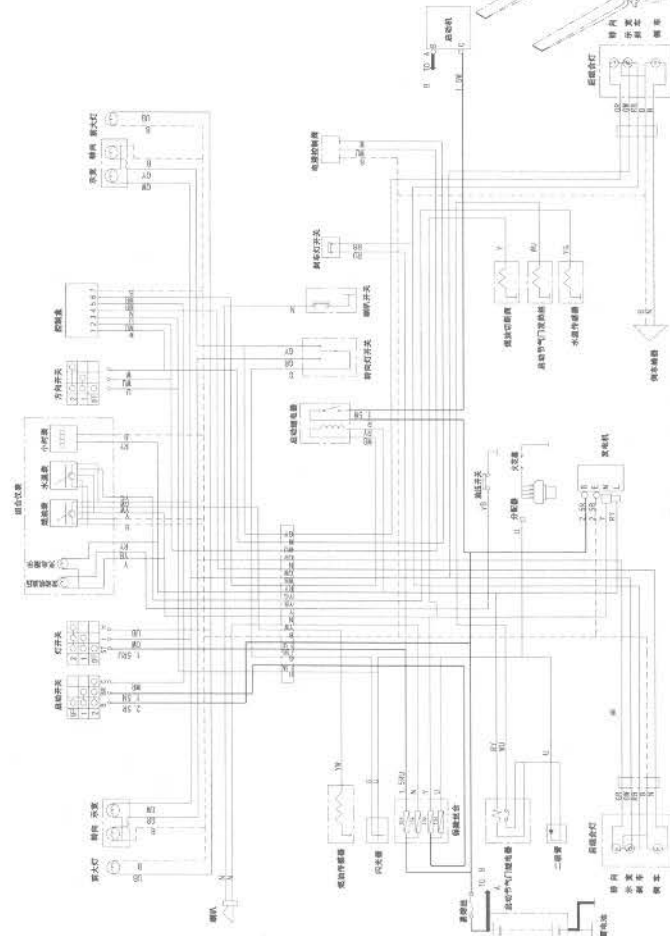

B

h2000

CPQ,CPQD20,25,30-R6
CPQ,CPQD20H,25H-R11
CPQ,CPQD30-R12
CPQ,CPQD35-R3,R4

序号 Item No	图号 Part No	零部件名称 Description	件数 Q'ty	备注 Remark
31	A22A2-40900	Fusible link wire	易熔线	1
32	Z8421-18214	Fule level sending unit	油量传感器	1
33	Z3652-42071G	Cable,head lamp	前大灯线束	2
34	Z8340-1H202	Relay	继电器	1 进口件, H20-11专用
35	Z8500-1D124	Horn	喇叭DL124ED	1
36	B0110-08016	Bolt	螺栓M8X16	1 GB5781-86
37	B5050-00008	Washer,lock	垫圈8	1 GB93-87
38	Z8730-0802A	Switch,turn signal	转向灯开关	1 JK802A
39	Z8600-120WD	Head lamp ass'y	前大灯	2 WD115X80-FC-1L
40	Z8610-12000	Front combination lamp ass'y	前组合灯	2 XH7-1L
41	Z8620-12000	Rear combination lamp ass'y	后组合灯	2 XH8-1L
42	A22A2-42000a	Mat	后组合灯垫	2
43	Z8740-0231D	Brake switch	脚制动开关	1 JK205
44	D07SG152	Flasher unit	闪光器	1
45	B1010-06010	Bolt	螺钉M6X10	1 GB65-85
46	Z8700-JK411	Switch	启动开关	1 JK411
47	D09JK107	Switch	灯开关	1 JK107
48	H24C2-40901	Rearview mirror	后视镜	1 选用
49	H24C2-40291	Control cable	喇叭连接线	1



图42/FIG42

电气系统/ELECTRIC SYSTEM

B2

序号 Item No	图号 Part No	零部件名称 Description	件数 Q'ty	备注 Remark
01	H94N2-43001	Cabinet harness	仪表架线束	1
02	H94N2-42001	Engine harness	发动机线束	1
03	D04ZB908JH	Combination M/T	组合仪表	1 See Fig.52
04	JQ1030/04	Relay	启动继电器	1
05	D06BX2081	Fuse box	保险丝盒	1
06	A22A2-40260	Rubber ring	出线胶圈	4
07	Z8510-120DZ	Back buzzer	倒车蜂鸣器	1 DJB-12B
08	B1010-06016	Bolt	螺钉M6X16	1 GB65-85
09	B5050-00006	Washer,lock	垫圈6	1 GB93-87
10	A22A2-40400	Cable	电瓶引线(-)	1
11	Z8100-12060	Battery	蓄电池	1 6-QA-60S
12	A91A2-40410	Cable	电瓶引线(+)	1
13	22492-42091G	Cable clip	电瓶引线卡	2
14	A22A2-40900	Fusible link wire	易熔线	1
15	Z8421-18214	Fule level sending unit	油量传感器	1
16	Z3652-42071G	Cable,head lamp	前大灯线束	2
17	Z8500-1D124	Horn	喇叭DL124ED	1
18	B0110-08016	Bolt	螺栓M8X16	1 GB5780-86
19	B5050-00008	Washer,lock	垫圈8	1 GB93-87
20	Z8730-0802A	Switch,turn signal	转向灯开关	1 JK802A
21	Z8600-120WD	Head lamp ass'y	前大灯	2 WD115X80-FC-1L
22	Z8610-12000	Front combination lamp ass'y	前组合灯	2 XH7-1L
23	Z8620-12000	Rear combination lamp ass'y	后组合灯	2 XH8-1L
24	A22A2-42000a	Mat	后组合灯垫	2
25	Z8740-0231D	Brake switch	脚制动开关	1 JK205
26	D07SG152	Flasher unit	闪光器	1
27	B1010-06010	Bolt	螺钉M6X10	2 GB65-85
28	Z8411-12703	Water temp sending unit	水温传感器	1
29	H24C2-40701	Rubber ring	防尘胶圈	2
30	Z8340-1H202	Relay	继电器	1

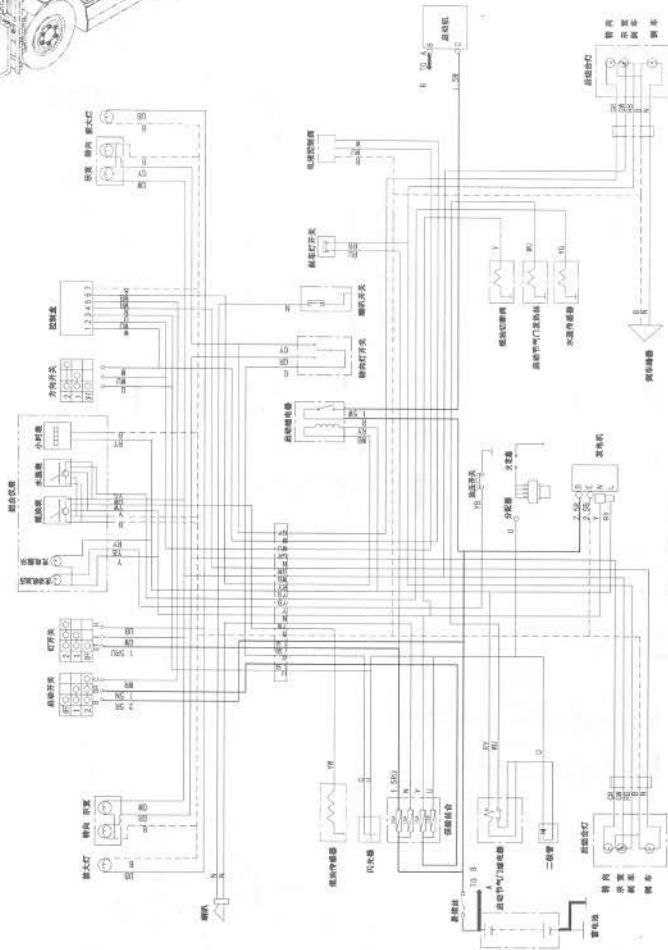
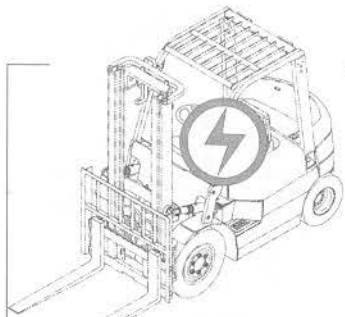
CPQ,CPQD20,25,30,35-ZJ2

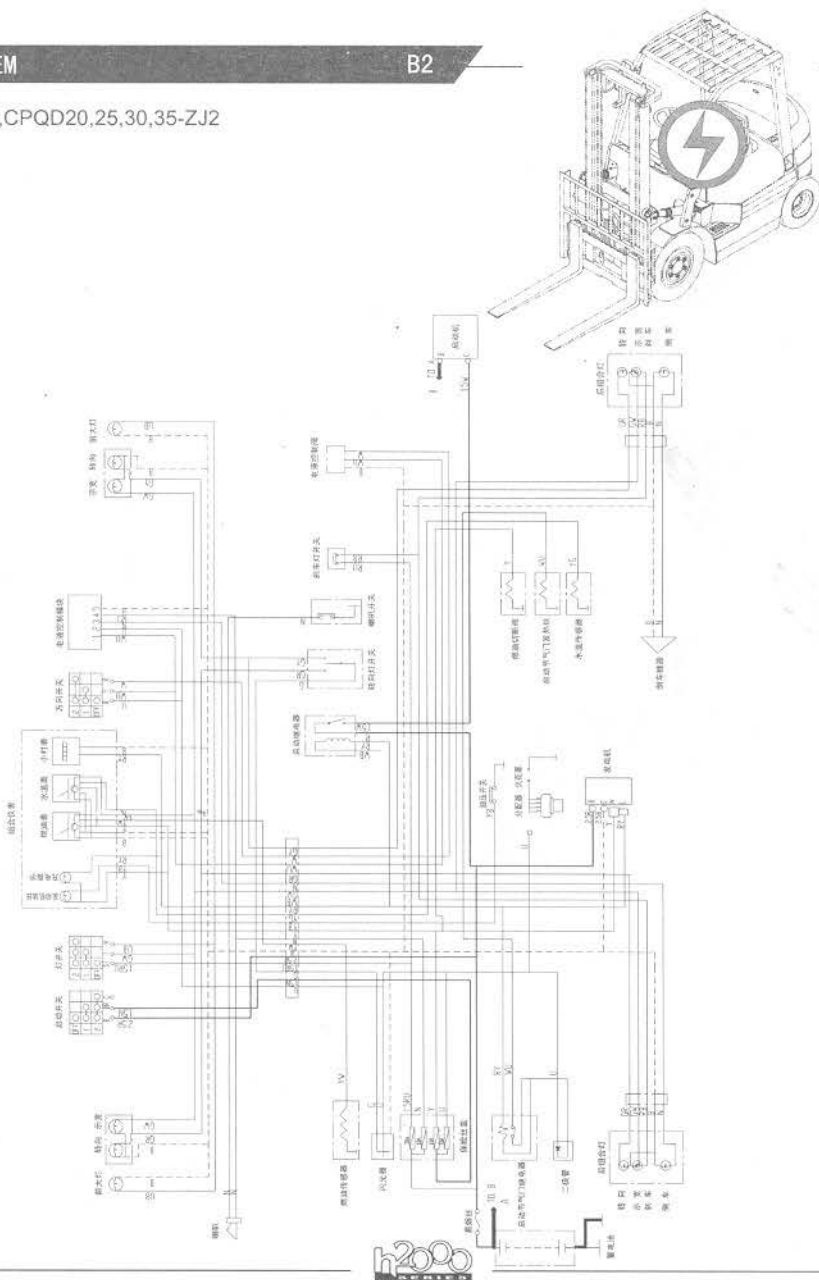

B

CPQ,CPQD20,25,30,35-ZJ3

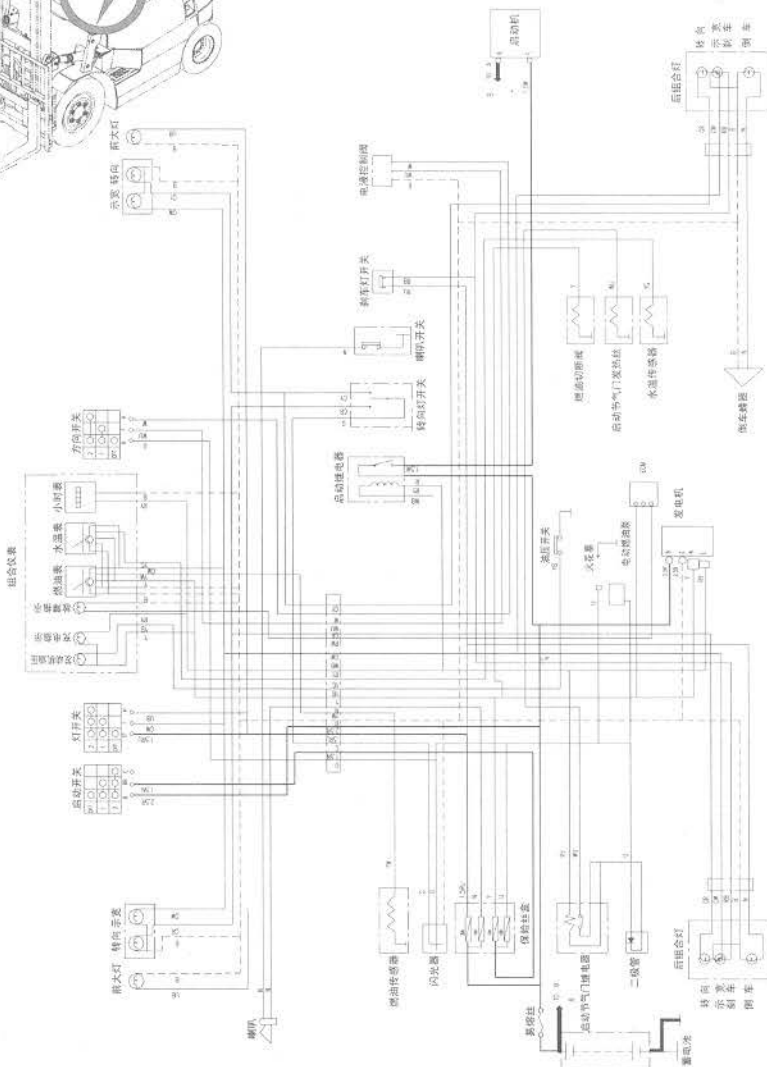
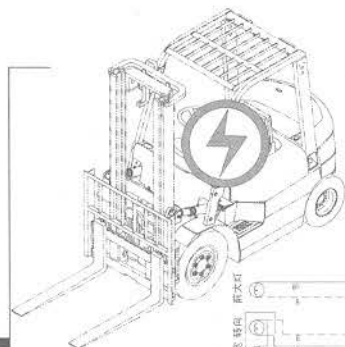

序号 Item No	图号 Part No	零部件名称 Description	件数 Qty	备注 Remark
A	H96N2-40001	Electric system	1	电气系统
01	H96N2-42001	Cabinet harness	1	仪表架线束
02	H96N2-41001	Engine harness	1	发动机线束
03	D04ZB908GZ	Combination M/T	1	组合仪表
04	JQ1030/04	Relay	1	启动继电器
05	D06BX2081	Fuse box	1	保险丝盒
06	A22A2-40260	Rubber ring	4	出线胶圈
07	Z8510-120DZ	Back buzzer	1	倒车蜂鸣器
08	B1010-06016	Bolt	1	螺钉M6X16
09	B5050-00006	Washer,lock	1	垫圈6
10	A22A2-40400	Cable	1	电瓶引线(-)
11	Z8100-12060	Battery	1	蓄电池
12	A91A2-40500	Cable	1	电瓶引线(+)
13	22492-42091G	Cable clip	2	电瓶引线卡
14	A22A2-40900	Fusible link wire	1	易熔线
15	Z8421-18214	Fule level sending unit	1	油量传感器
16	23652-42071G	Cable,head lamp	2	前大灯线束
17	Z8500-1D124	Horn	1	喇叭DL124ED
18	B0110-08016	Bolt	1	螺栓M8X16
19	B5050-00008	Washer,lock	1	垫圈8
20	Z8730-0802A	Switch,turn signal	1	转向灯开关
21	Z8600-120WD	Head lamp ass'y	2	前大灯
22	Z8610-12000	Front combination lamp ass'y	2	前组合灯
23	Z8620-12000	Rear combination lamp ass'y	2	后组合灯
24	A22A2-42000a	Mat	2	后组合灯垫
25	Z8740-0231D	Brake switch	1	脚制动开关
26	D07SG152	Flasher unit	1	闪光器
27	B1010-06010	Bolt	2	螺钉M6X10
28	Z8411-12703	Water temp sending unit	1	水温传感器
29	H24C2-40701	Rubber ring	2	防尘胶圈
30	Z8340-1H202	Relay	1	继电器

图44/FIG44

电气系统/ELECTRIC SYSTEM

B4

序号 Item No	图号 Part No	零部件名称 Description	件数 Q'ty	备注 Remark
01	H25S2-40213	Cabinet harness 仪表架线束	1	机械或液力变速箱
02	H25S2-40412	Cabinet harness 仪表架线束	1	电液控制变速箱
03	H25S2-40223	Engine harness 发动机线束	1	机械或液力变速箱 CPC(D)20-30-W7,W8 CPC(D)35-W5,W6
-	H25N2-40223	Engine harness 发动机线束	1	机械或液力变速箱 CPC(D)20-30-W8 CPC(D)35-W4
04	H25S2-40422	Engine harness 发动机线束	1	电液控制变速箱 CPC(D)20-30-W7,W8 CPC(D)35-W5,W6
-	H25N2-40422	Engine harness 发动机线束	1	电液控制变速箱 CPC(D)20-30-W8 CPC(D)35-W4
05	H24C2-40231	Rear head guard harness 后护顶架线束	2	
06	Z8498-ZB103	Combination M/T H2000型组合仪表	1	See Fig.50
07	H24C2-40511	Combination M/T H2001型组合仪表	1	See Fig.51
08	A22A2-40800	Shuck 上壳	1	
09	A22A2-40810	Shuck 下壳	1	
10	A22A2-40820	Cover 后盖	1	
11	H24C2-40601	Control box 控制盒	1	电液控制变速箱
12	A73J2-41302	Switch,direction 方向开关	1	电液控制变速箱
13	JQ1030/04	Relay 启动继电器	1	
14	D06BX2081	Fuse box 保险丝盒	1	
15	Z9260-30100	Belt clip 捆扎带3X100	12	
16	Z9260-40200	Belt clip 捆扎带4X200	8	
17	Z9260-48350	Belt clip 捆扎带4.8X350	2	
18	H24C2-42131	Belt clip 固定可开式锁式扎带	14	
19	HRH24C2404	Rubber ring 出线胶圈	5	
20	H24C2-40701	Rubber ring 防尘胶圈	2	
21	H24C2-40431	Cable,caution light 警示灯线束	1	选用
22	H24C2-40491	Caution light 警示灯	1	选用
23	Z8411-12703	Water temp sending unit 水温传感器	1	
24	Z8510-120DZ	Back buzzer 倒车蜂鸣器	1	DJB-12B
25	B1110-06016	Bolt 螺钉M6X16	1	GB65-85
26	B5050-00006	Washer,lock 垫圈6	1	GB93-87
27	A22A2-40400	Cable 电瓶引线(-)	1	
28	D016-QW-80	Battery 蓄电池	1	6-QW-80

CPC,CPCD20,25,30-W7,W8,W9
CPC,CPCD35-W4,W5,W6

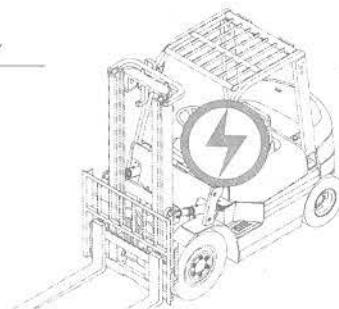
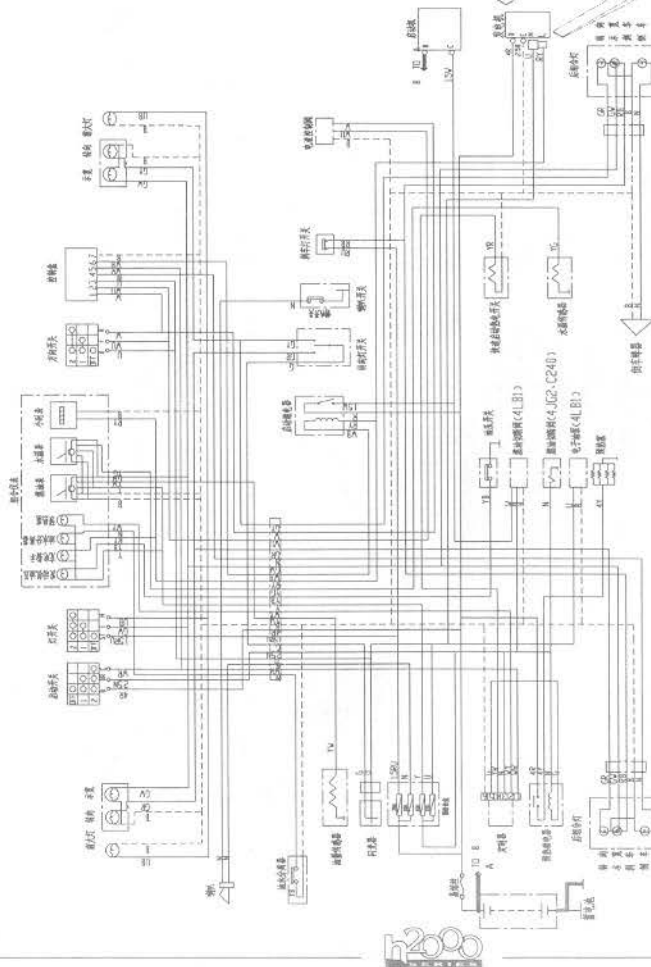

B

CPC, CPCD20, 25, 30-W7, W8, W9
CPC, CPCD35-W4, W5, W6

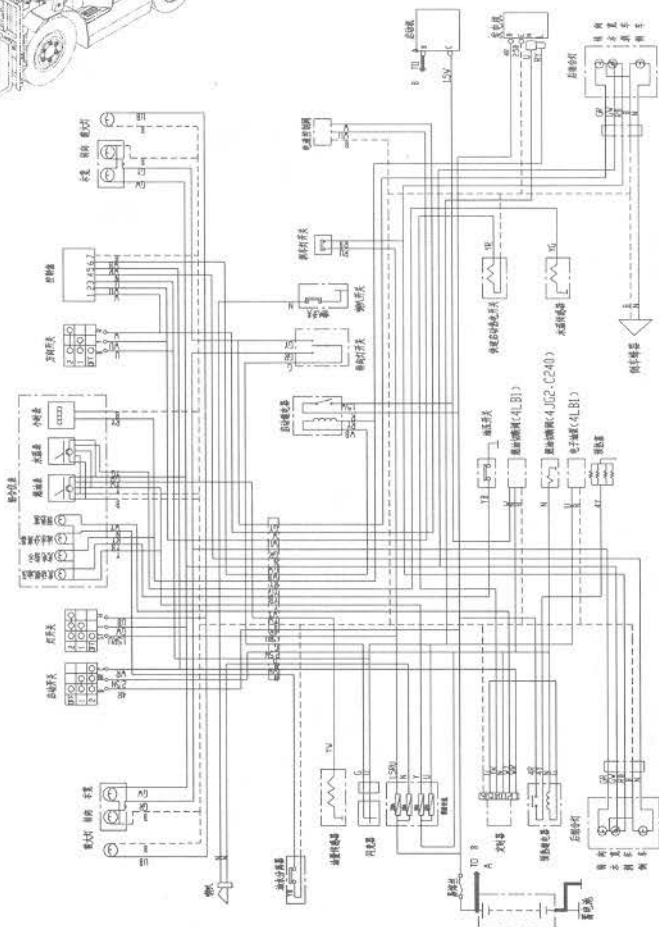
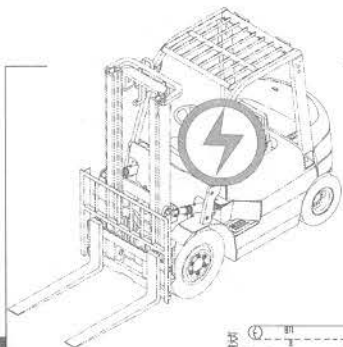

序号 Item No	图号 Part No	零部件名称 Description	件数 Qty	备注 Remark
29	A22A2-40420	Cable	1	电瓶引线(+)
30	22492-42091G	Cable clip	2	电瓶引线卡
31	A22A2-40900	Fusible link wire	1	易熔线
32	Z8421-18214	Fule level sending unit	1	油量传感器
33	23652-42071G	Cable,head lamp	2	前大灯线束
34	Z8900-12Q0S	Timer	1	定时器
35	Z8930-10000	Relay	1	继电器
36	Z8500-1D124	Horn	1	喇叭DL124ED
37	B0110-08016	Bolt	1	螺栓M8X16
38	B5050-00008	Washer,lock	1	垫圈8
39	Z8730-0802A	Switch,turn signal	1	转向灯开关
40	Z8600-120WD	Head lamp ass'y	2	前大灯
41	Z8610-12000	Front combination lamp ass'y	2	前组合灯
42	Z8620-12000	Rear combination lamp ass'y	2	后组合灯
43	A22A2-42000a	Mat	2	后组合灯垫
44	Z8740-0231D	Brake switch	1	脚制动开关
45	D07SG152	Flasher unit	1	闪光器
46	B1110-06010	Bolt	1	螺钉M6X10
47	Z8700-JK411	Switch	1	启动开关
48	D09JK211	Switch	1	灯开关
49	H24C2-40901	Rearview mirror	1	后视镜
				进口件 21152-42012
				进口件 21152-42021
				GB5781-86
				GB93-87
				JK802A
				WD115X80-FC-1L
				XH7-1L
				XH8-1L
				JK205
				JK411
				J K 211
				选用

图45/FIG45

电气系统/ELECTRIC SYSTEM

B5

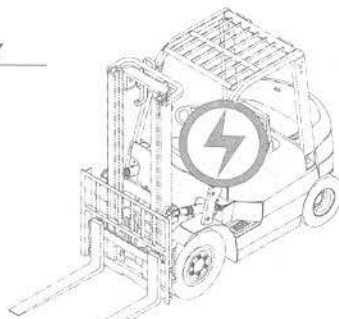

序号 Item No	图号 Part No	零部件名称 Description	件数 Q'ty	备注 Remark
1	H25S2-40213	Cabinet harness 仪表架线束	1	机液控制
2	H25S2-40412	Cabinet harness 仪表架线束	1	电液控制
3	H21U2-40221	Engine harness 发动机线束	1	机液控制
4	H21U2-40421	Engine harness 发动机线束	1	电液控制
5	H24C2-40231	Rear head guard harness 后护顶架线束	2	
6	Z8498-ZB103	Combination M/T H2000型组合仪表	1	标准型 See Fig.50
7	H24C2-40511	Combination M/T H2001型组合仪表	1	选用 See Fig.51
8	A22A2-40800	Shuck 上壳	1	
9	A22A2-40810	Shuck 下壳	1	
10	A22A2-40820	Cover 后盖	1	
11	H24C2-40601	Control box 控制盒	1	电液控制
12	A73J2-41302	Switch,direction 方向开关	1	电液控制
13	JQ1030/04	Relay 启动继电器	1	
14	Z9260-40100	Belt clip 捆扎带4X100	12	
15	Z9260-40200	Belt clip 捆扎带4X200	8	
16	Z9260-48350	Belt clip 捆扎带4. 8X350	2	
17	H24C2-42131	Belt clip 固定可开式锁式扎带	14	
18	D06BX2083	Fuse box 保险丝盒	1	
19	HRH24C2404	Rubber ring 出线胶圈	5	
20	H24C2-40701	Rubber ring 防尘胶圈	1	
21	H24C2-40431	Wiring hamss,Caution light 警示灯线束	1	
22	H24C2-40491	Caution light 警示灯	1	
23	Z8411-12703	Water temp sending unit 水温传感器	1	
24	Z8510-120DZ	Back buzzer 倒车蜂鸣器	1	DJB-128
25	B1110-06016	Bolt 螺钉M6X16	1	GB65-85
26	B5050-00006	Washer,lock 垫圈6	1	GB93-87
27	A22A2-40400	Cable 电瓶引线(-)	1	
28	Z8110-12105	Battery 蓄电池	1	6-QA-105S
29	A22A2-40420	Cable 电瓶引线(+)	1	
30	Z2492-42091G	Cable clip 电瓶引线卡	2	

CPC,CPCD20,25,30,35-Xs1

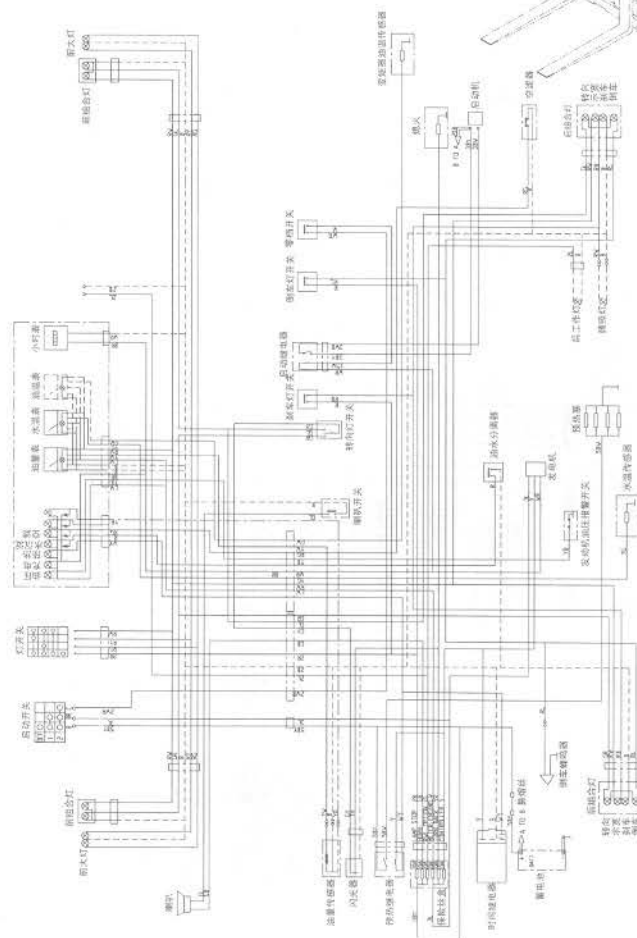

B

CPC,CPCD20,25,30,35-Xs1

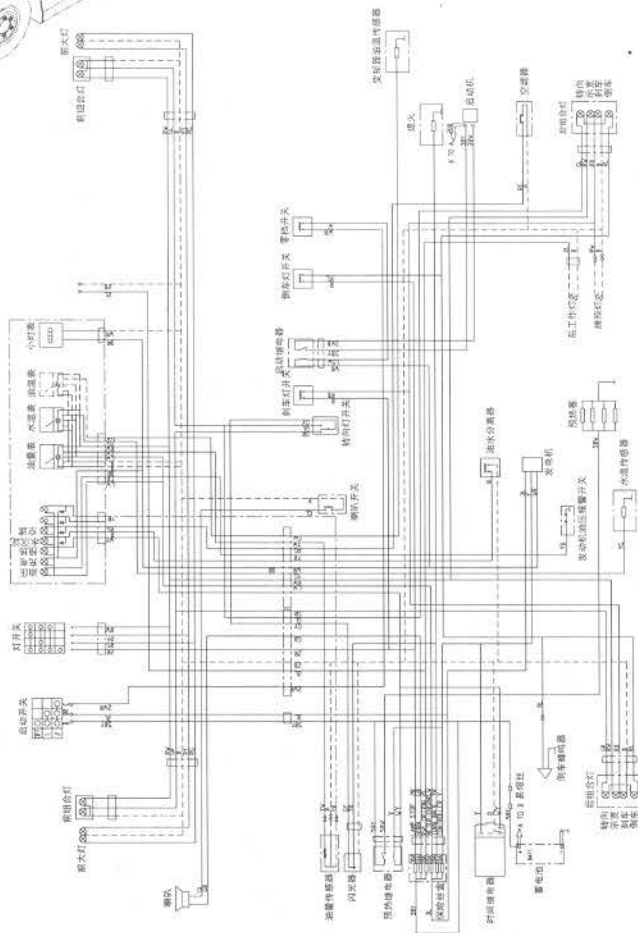
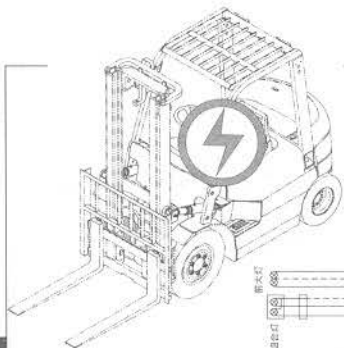

序号 Item No	图号 Part No	零部件名称 Description	件数 Q'ty	备注 Remark
31	A22A2-40900	Fusible link wire	易熔线 2	
32	Z8421-18214	Fule level sending unit	油量传感器 1	
33	Z3652-42071G	Cable,head lamp	前大灯线束 2	
34	JQK1	Relay	时间继电器 1	
35	JQ1030/04	Relay	预热继电器 1	
36	Z8500-1D124	Horn	喇叭DL124ED 1	
37	B0110-08016	Bolt	螺栓M8X16 1	GB5781-86
38	B5050-00008	Washer ,lock	垫圈8 1	GB93-87
39	Z8730-0802A	Switch,turn signal	转向灯开关 1	JK802A
40	Z8600-120WD	Head lamp ass'y	前大灯 2	WD115x80-FC-1L
41	Z8610-12000	Front combination lamp ass'y	前组合灯 2	XH7-1L
42	Z8620-12000	Rear combination lamp ass'y	后组合灯 2	XH8-1L
43	A22A2-42000a	Mat	后组合灯垫 2	
44	Z8740-0231D	Brake switch	脚制动开关 1	JK205
45	D07SG152	Flasher unit	闪光器 1	
46	B1110-06010	Bolt	螺钉M6X10 1	
47	Z8700-JK411	Key switch	启动开关 1	JK411
48	D09JK211	light switch	灯开关 1	JK211
49	H24C2-40901	Rearview mirror	后视镜 1	选用

序号 Item No	图号 Part No	零部件名称 Description	件数 Q'ty	备注 Remark
1	A23F2-40214	Cabinet harness 仪表架线束	1	机液控制
2	H25S2-40412	Cabinet harness 仪表架线束	1	电液控制
3	A91A2-40224	Engine harness 发动机线束	1	机液控制
4	H93C2-40421	Engine harness 发动机线束	1	电液控制
5	H24C2-40231	Rear head guard harness 后护顶架线束	2	
6	Z8498-ZB103	Combination M/T H2000型组合仪表	1	标准型 See Fig.50
7	H24C2-40511	Combination M/T H2001型组合仪表	1	选用 See Fig.51
8	A22A2-40800	Shuck 上壳	1	
9	A22A2-40810	Shuck 下壳	1	
10	A22A2-40820	Cover 后盖	1	
11	H24C2-40601	Control box 控制盒	1	电液控制
12	A73J2-41302	Switch,direction 方向开关	1	电液控制
13	Z9260-40100	Belt clip 捆扎带4X100	12	
14	Z9260-40200	Belt clip 捆扎带4X200	8	
15	Z9260-48350	Belt clip 捆扎带4.8X350	2	
16	Z9260-800350	Belt clip 捆扎带8X350	4	
17	D06BX2081	Fuse box 保险丝盒	1	
18	HRH24C2404	Rubber ring 出线胶圈	7	
19	Z8411-12703	Water temp sending unit 水温传感器	1	
20	Z8510-120DZ	Back buzzer 倒车蜂鸣器	1	DJB-128
21	B1110-06016	Bolt 螺钉M6X16	3	GB65-85
22	B5050-00006	Washer,lock 垫圈6	3	GB93-87
23	HRA91A2402	Cable 电瓶引线	1	
24	D016-QW-120	Battery 蓄电池	1	6-QW-120
25	22492-42091G	Cable clip 电瓶引线卡	1	
26	A22A2-40900	Fusible link wire 易熔线	2	
27	Z8421-18214	Fule level sending unit 油量传感器	1	
28	23652-42071G	Cable,head lamp 前大灯线束	1	
29	JQK1	Relay 时间继电器	1	
30	JQ1030/04	Relay 预热继电器	2	1件用于启动继电器

CPC,CPD20,25,30-X6
CPC,CPD35-X2

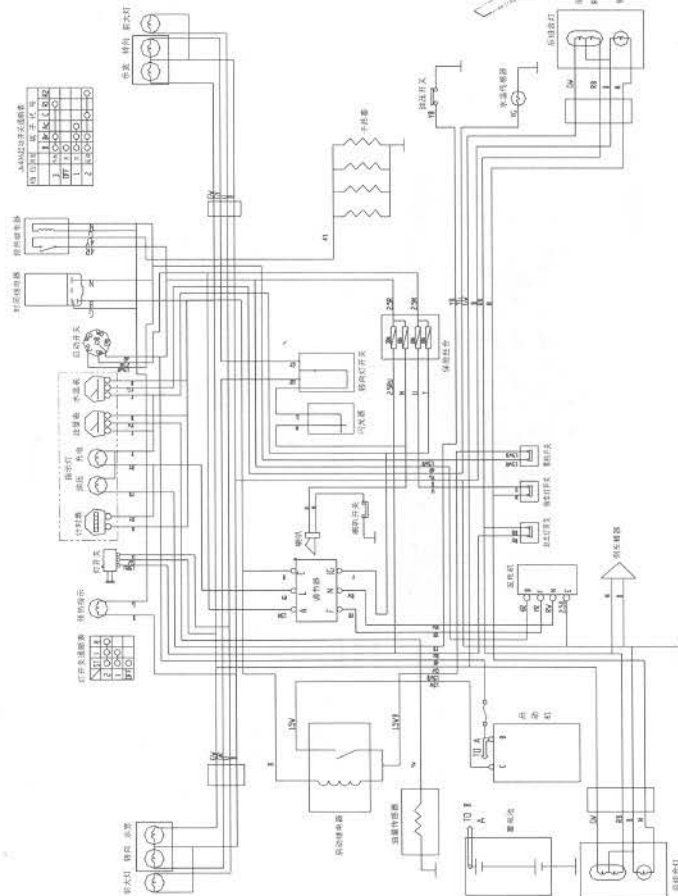

h2000

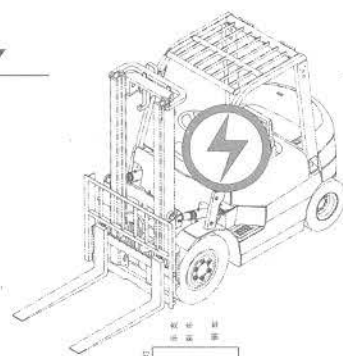

CPC,CPCD20,25,30-X6
CPC,CPCD35-X2

序号 Item No	图号 Part No	零部件名称 Description	件数 Q'ty	备注 Remark	
31	Z8500-1D124	Horn	喇叭DL124ED	1	
32	B0110-08016	Bolt	螺栓M8X16	1	GB5781-86
33	B5050-00008	Washer,lock	垫圈8	1	GB93-87
34	Z8730-0802A	Switch,turn signal	转向灯开关	1	JK802A
35	Z8600-120WD	Head lamp ass'y	前大灯	2	WD115x80-FC-1L
36	Z8610-12000	Front combination lamp ass'y	前组合灯	2	XH7-1L
37	Z8620-12000	Rear combination lamp ass'y	后组合灯	2	XH8-1L
38	A22A2-42000a	Mat	后组合灯垫	2	
39	Z8740-0231D	Brake switch	脚制动开关	1	JK205
40	D07SG152	Flasher unit	闪光器	1	
41	B1110-06010	Bolt	螺钉M6X10	1	
42	Z8300-10147	Adjustment	调节器	1	JFT147
43	D09JK211	Light switch	灯开关	1	JK211
44	H24C2-40701	Rubber ring	防尘胶圈	1	
45	B5210-00006	Washer	平垫圈6	2	GB97.1-85
46	H24C2-40491	Caution light	警示灯	1	选用件
47	H24C2-40431	Cable,caution light	警示灯线束	2	选用件
48	H24C2-40901	Rearview mirror	后视镜	1	选用件

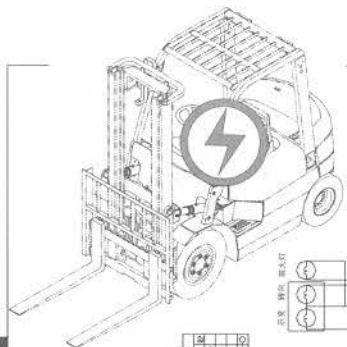

1	2	3	4	5	6	7	8	9	10
1	2	3	4	5	6	7	8	9	10

转向灯总成
喇叭
闪光器
转向灯开关
制动开关
大灯总成
组合灯总成
后视镜

转向灯
喇叭
闪光器
转向灯开关
制动开关
大灯总成
组合灯总成
后视镜

转向灯总成
喇叭
闪光器
转向灯开关
制动开关
大灯总成
组合灯总成
后视镜

转向灯
喇叭
闪光器
转向灯开关
制动开关
大灯总成
组合灯总成
后视镜

图47/FIG47

电气系统/ELECTRIC SYSTEM

B7

序号 Item No	图号 Part No	零部件名称 Description	件数 Q'ty	备注 Remark
1	H25S2-40213	Cabinet harness 仪表架线束	1	机液控制
2	H25S2-40412	Cabinet harness 仪表架线束	1	电液控制
3	H97Y2-40221	Engine harness 发动机线束	1	机液控制
4	H97Y2-40421	Engine harness 发动机线束	1	电液控制
5	H24C2-40231	Rear head guard harness 后护顶架线束	2	
6	P62B2-40201	Combination M/T H2000型组合仪表	1	标准 See Fig.50
-	D04ZB908JH	Combination M/T 组合仪表	1	选用 See Fig.52
7	D09JK211	Light switch 灯开关	1	JK211
8	A22A2-40800	Shuck 上壳	1	
9	A22A2-40810	Shuck 下壳	1	
10	A22A2-40820	Cover 后盖	1	
11	H24C2-40601	Control box 控制盒	1	电液控制
12	A73J2-41302	Switch,direction 方向开关	1	电液控制
13	5-82550-029-0	Relay 继电器	1	
14	Z9260-40100	Belt clip 捆扎带4X100	12	
15	Z9260-40200	Belt clip 捆扎带4X200	8	
16	Z9260-48350	Belt clip 捆扎带4.8X350	2	
17	H24C2-42131	Belt clip 固定可开式锁式扎带	14	
18	D06BX2083	Fuse box 保险丝盒	1	
19	HRH24C2404	Rubber ring 出线胶圈	5	
20	H24C2-40701	Rubber ring 防尘胶圈	1	
21	H24C2-40431	Wiring harness,Caution light 警示灯线束	1	
22	H24C2-40491	Caution light 警示灯	1	
23	Z8411-12703	Water temp sending unit 水温传感器	1	
24	Z8510-120DZ	Back buzzer 倒车蜂鸣器	1	DJB-128
25	B1110-06016	Bolt 螺钉M6X16	1	GB65-85
26	B5050-00006	Washer,lock 垫圈6	1	GB93-87
27	24942-42081G	Cable 电瓶引线(-)	1	
28	D016-QW-80	Battery 蓄电池	1	6-QW-80
29	A22A2-40420	Cable 电瓶引线(+)	1	

CPC,CPCD20,25,30,35-HJ

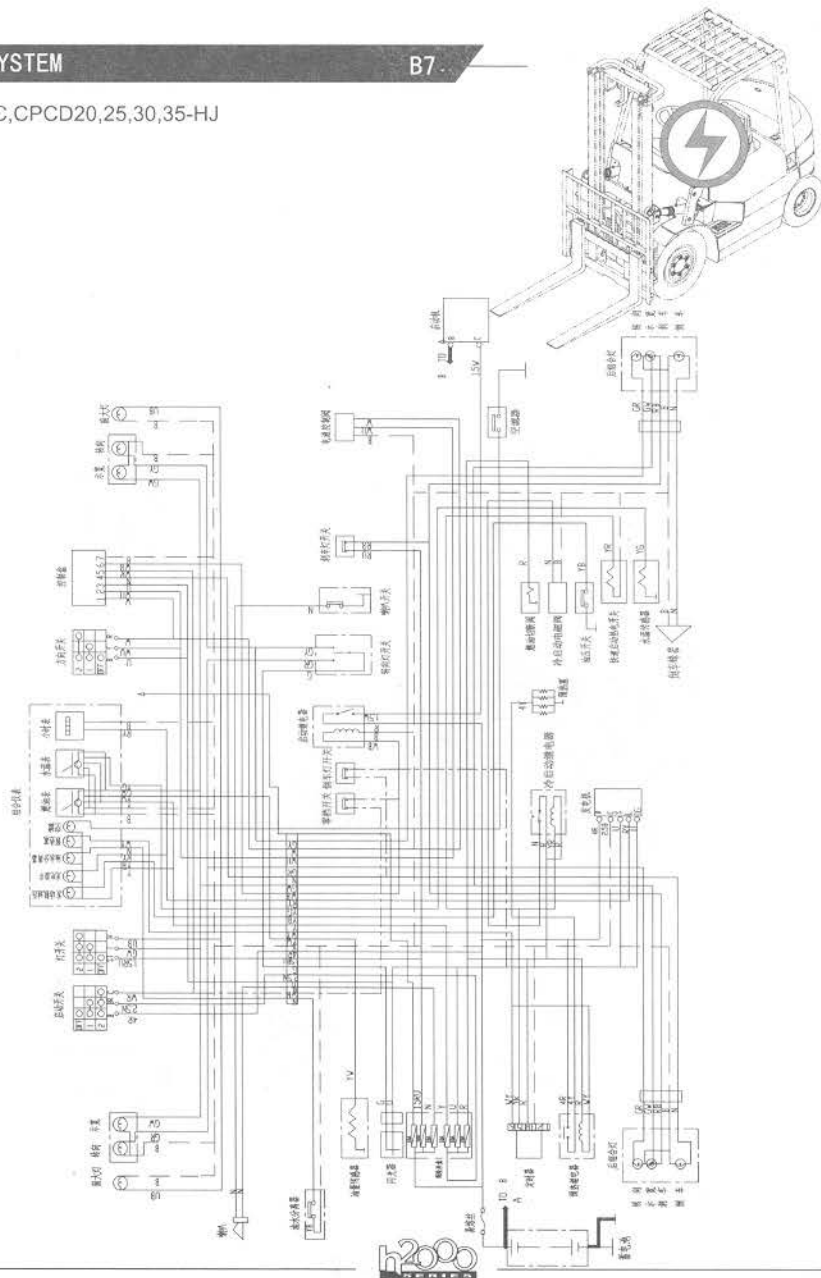

B

CPC,CPCD20,25,30,35-HJ

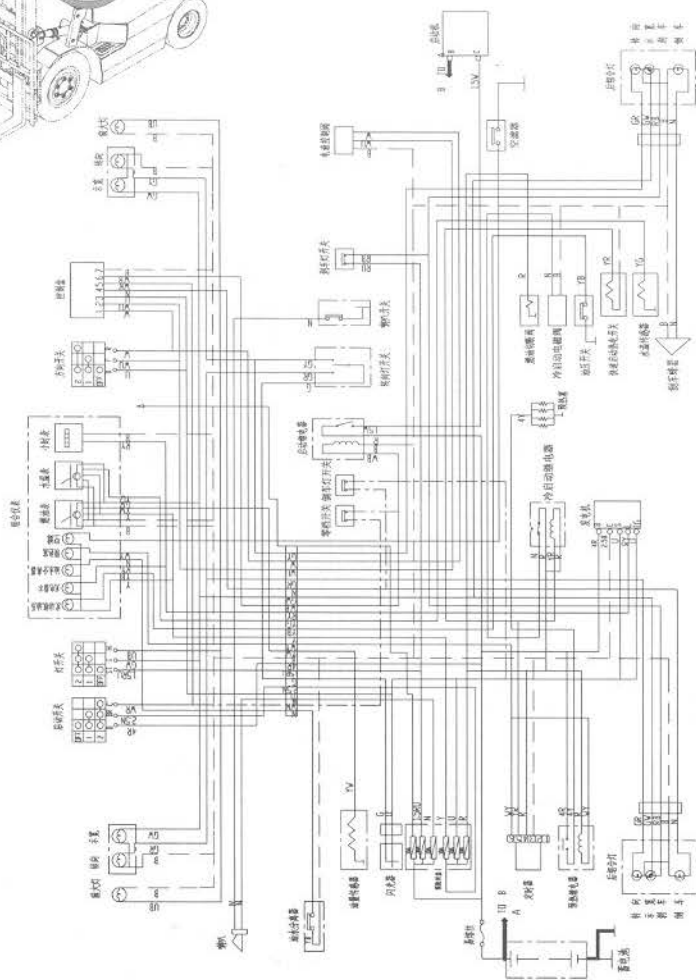
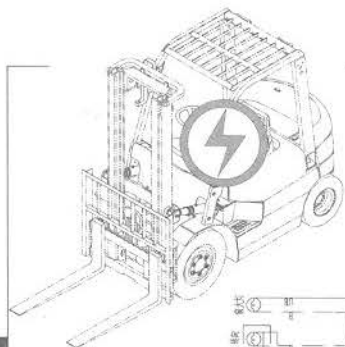

序号 Item No	图号 Part No	零部件名称 Description	件数 Q'ty	备注 Remark
30	Z2492-42091G	Cable clip	电瓶引线卡	2
31	A22A2-40900	Fusible link wire	易熔线	2
32	Z8421-18214	Fule level sending unit	油量传感器	1
33	Z3652-42071G	Cable,head lamp	前大灯线束	2
34	JQK1	Relay	时间继电器	1
35	JQ1030/04	Relay	预热继电器	2
			1件用于启动继电器	
36	Z8500-1D124	Horn	喇叭DL124ED	1
37	B0110-08016	Bolt	螺栓M8X16	1
			GB5781-86	
38	B5050-00008	Washer,lock	垫圈8	1
			GB93-87	
39	Z8730-0802A	Switch,turn signal	转向灯开关	1
			JK802A	
40	Z8600-120WD	Head lamp ass'y	前大灯	2
			WD115x80-FC-1L	
41	Z8610-12000	Front combination lamp ass'y	前组合灯	2
			XH7-1L	
42	Z8620-12000	Rear combination lamp ass'y	后组合灯	2
			XH8-1L	
43	A22A2-42000a	Mat	后组合灯垫	2
44	Z8740-0231D	Brake switch	脚制动开关	1
			JK205	
45	D07SG152	Flasher unit	闪光器	1
46	B1010-06010	Bolt	螺钉M6X10	1
			GB65-85	
47	Z8700-JK411	Key switch	启动开关	1
			JK411	

图48/FIG48

电气系统/ELECTRIC SYSTEM

B8

序号 Item No	图号 Part No	零部件名称 Description	件数 Q'ty	备注 Remark
1	A23F2-40214	Cabinet harness	1	机械或液力变速箱
2	H25S2-40411	Cabinet harness	1	电液控制变速箱
3	H99Y2-40221	Engine harness	1	机械或液力变速箱
4	H99Y2-40421	Engine harness	1	电液控制变速箱
5	H24C2-40231	Rear head guard harness	2	
6	D04ZB908JH	Combination M/T	1	See Fig.52
7	H24C2-40701	Rubber ring	2	
8	A22A2-40800	Shuck	1	上壳
9	A22A2-40810	Shuck	1	下壳
10	A22A2-40820	Cover	1	后盖
11	H24C2-40601	Control box	1	电液控制变速箱
12	A73J2-41302	Switch,direction	1	电液控制变速箱
13	Z9260-30100	Belt clip	12	捆扎带3X100
14	Z9260-40200	Belt clip	8	捆扎带4X200
15	Z9260-48350	Belt clip	2	捆扎带4.8X350
16	Z9260-80350	Belt clip	4	捆扎带8X350
17	D06BX2081	Fuse box	1	BX2081
18	HRH24C2404*1	Rubber ring	7	出线胶圈
-	HRH24C2404*2	Rubber ring	7	出线胶圈
19	Z8510-120DZ	Back buzzer	1	DJB-128
20	B1010-06016	Bolt	1	GB65-85
21	B5050-00006	Washer,lock	1	GB93-87
22	A91A2-40600	Cable	1	电瓶引线(+)
-	24942-42081G	Cable	1	电瓶引线(-)
23	D016-QW-80	Battery	1	6-QW-80
24	HAH92A2401 22492-42091G	Cable clip	1	电瓶引线卡
-	HAH92A2401 22492-42092G	Cable clip	1	电瓶引线卡
25	A22A2-40900	Fusible link wire	2	易熔线
26	Z8421-18214	Fule level sending unit	1	油量传感器
27	Z3652-42071G	Cable,head lamp	1	前大灯线束

CPC,CPCD20,25,30,35-D

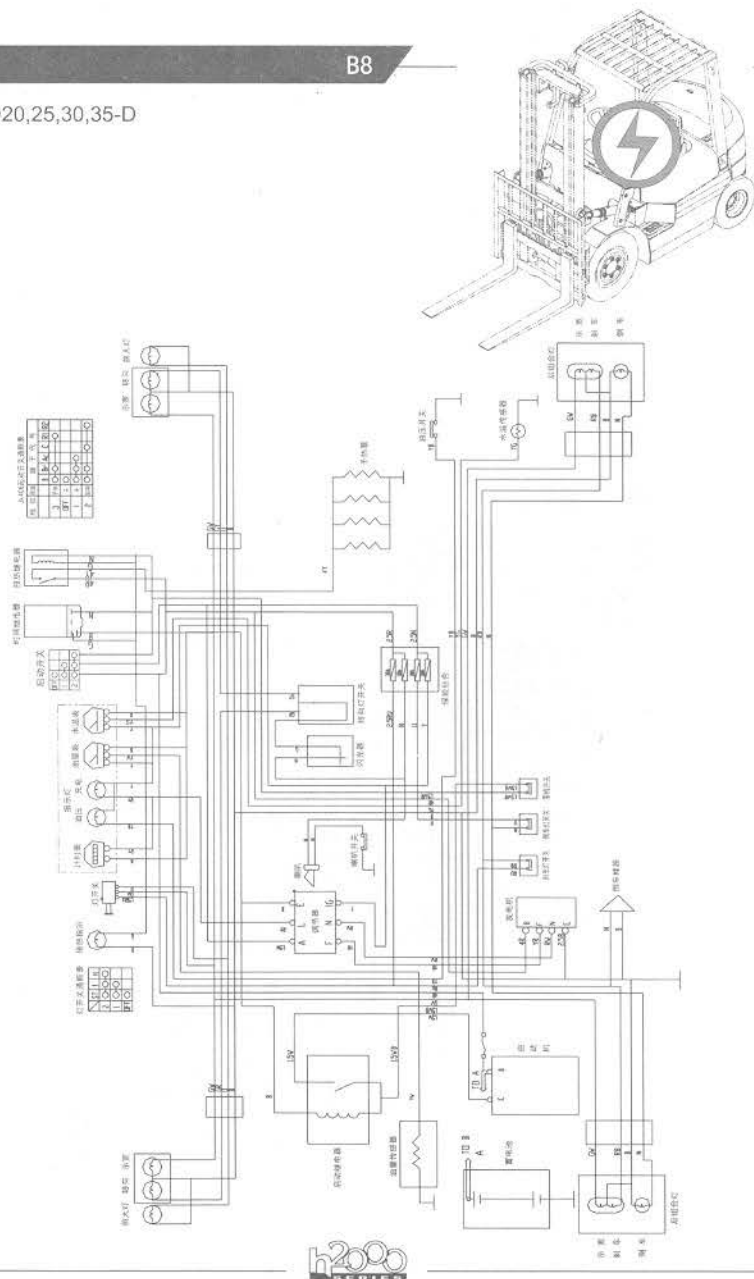

B

CPC, CPCD20, 25, 30, 35-D

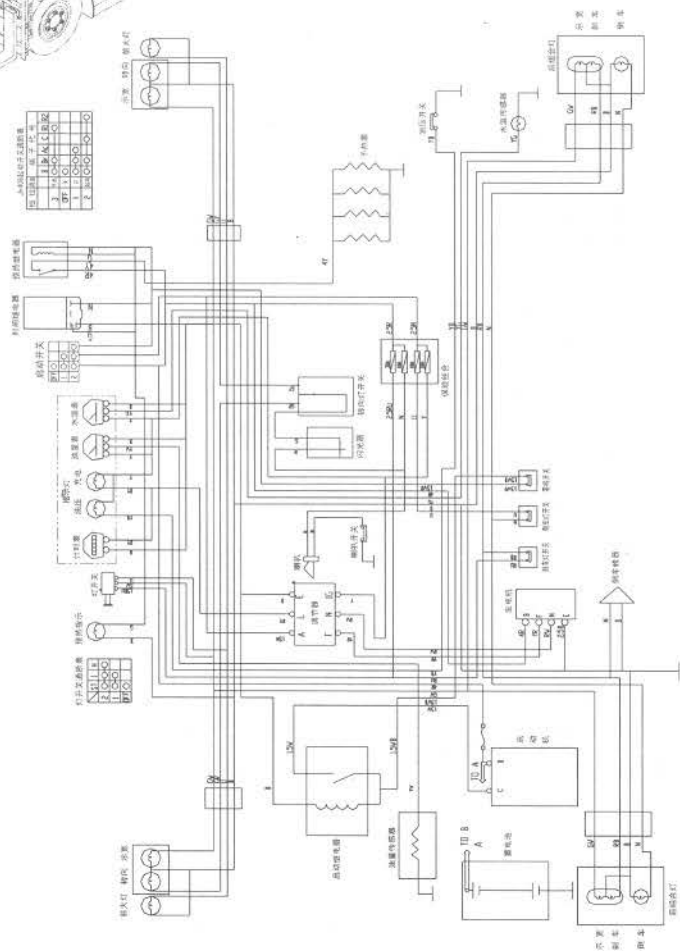

序号 Item No	图号 Part No	零部件名称 Description	件数 Qty	备注 Remark
28	JQK1	Relay	1	时间继电器
29	JQ1030/04	Relay	2	预热继电器 1件用于启动继电器
30	Z8500-1D124	Horn	1	喇叭DL124ED
31	B0110-08016	Bolt	1	螺栓M8X16 GB5781-86
32	B5050-00008	Washer,lock	1	垫圈8 GB93-87
33	Z8730-0802A	Switch,turn signal	1	转向灯开关 JK802A
34	Z8600-120WD	Head lamp ass'y	2	前大灯 WD115X80-FC-1L
35	Z8610-12000	Front combination lamp ass'y	2	前组合灯 XH7-1L
36	Z8620-12000	Rear combination lamp ass'y	2	后组合灯 XH8-1L
37	A22A2-42000a	Mat	2	后组合灯垫
38	Z8740-0231D	Brake switch	1	脚制动开关 JK205
39	D07SG152	Flasher unit	1	闪光器 SG152
40	B1010-06010	Bolt	1	螺钉M6X10 GB65-85
41	B5050-00006	Washer,lock	2	垫圈6 GB93-87
42	B5210-00006	Washer	2	垫圈6 GB96-85
43	H24C2-40491	Caution light	1	警示灯
44	H24C2-40431	Cable,caution light	2	警示灯线束
45	H24C2-40901	Rearview mirror	1	后视镜
46	D09JK211	Light switch	1	灯开关 JK211
47	D03RF121001	Fuel electromagnetic valve	1	燃油电磁阀 RF-12-100-1
48	B1110-06016	Screw	2	螺钉M6X16 GB67-85
49	B5050-00006	Washer,lock	2	垫圈6 GB93-87
50	B5210-00006	Washer	2	垫圈6 GB96-85
51	H99Y2-40501	Bracket	1	熄火支架
52	B1210-08010	Screw	2	螺钉M8X10 GB818-85
53	B5050-00008	Washer,lock	2	垫圈8 GB93-87
54	B5210-00008	Washer	2	垫圈8 GB96-85
55	3C53-00-09	Yoke	1	耳子
56	B3010-02020	Pin	1	开口销2X20 GB91-86
57	B5310-00006	Washer	1	垫圈6 GB97.1-85

图49/FIG49

电气系统/ELECTRIC SYSTEM

B9

序号 Item No	图号 Part No	零部件名称 Description	件数 Q'ty	备注 Remark
A	H2B92-40001	Electric system 电气系统	1	
01	A23F2-40214	Cabinet harness 仪表架线束	1	
02	H2B92-40221	Engine harness 发动机线束	1	
03	H24C2-40231	Rear head guard harness 后护顶架线束	2	
04	D04ZB908	Combination M/T ZB908型组合仪表总成	1	ZB908 See Fig.52
05	H24C2-40701	Rubber ring 防尘胶圈	2	
06	A22A2-40800	Shuck 上壳	1	
07	A22A2-40810	Shuck 下壳	1	
08	A22A2-40820	Cover 后盖	1	
09	Z9260-30100	Belt clip 捆扎带3x100	12	
10	Z9260-40200	Belt clip 捆扎带4x200	8	
11	Z9260-48350	Belt clip 捆扎带4.8x350	2	
12	Z9260-80350	Belt clip 捆扎带8x350	4	
13	D06BX2081	Fuse box 保险丝盒	1	BX2081
14	HRH24C2404	Rubber ring 出线胶圈	4	
15	Z8510-120DZ	Back buzzer 倒车蜂鸣器	1	DJB-12B
16	B1010-06016	Screw 螺钉M6x16	1	GB65-85
17	B5050-00006	Washer,lock 垫圈6	1	GB93-87
18	A91A2-40600	Cable 电瓶引线(+)	1	
19	24942-42081G	Cable 电瓶引线(-)	1	
20	D016-QW-80	Battery 蓄电池	1	6-QW-80
21	HAH92A2401	Cable clip 电瓶引线卡	2	
22	A22A2-40900	Fusibl link wire 易熔线	1	
23	Z8421-18214	Fuel level sensor 油量传感器	1	
24	Z3652-42071G	Cable,head lamp 前大灯线束	2	
25	JQK1	Relay 时间继电器	1	
26	JQ1030/04	Re;ay 继电器	2	1件用于启动继电器
27	Z8500-1D124	Horn 喇叭DL124	1	
28	B0110-08016	Bolt 螺栓M8x16	1	GB5781-86
29	B5050-00008	Washer,lock 垫圈8	1	GB93-87

CPC,CPCD20,25,30-Ku1

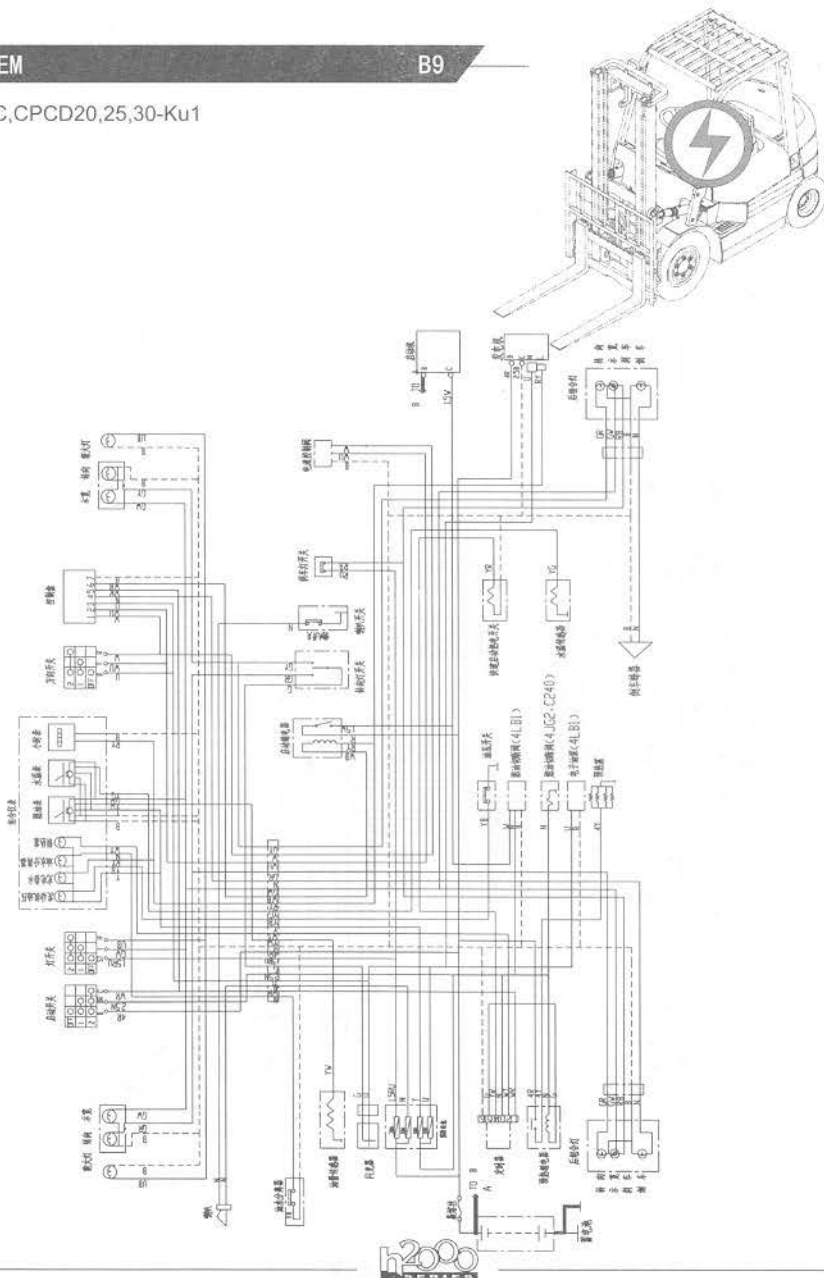

B

CPC,CPCD20,25,30-Ku1

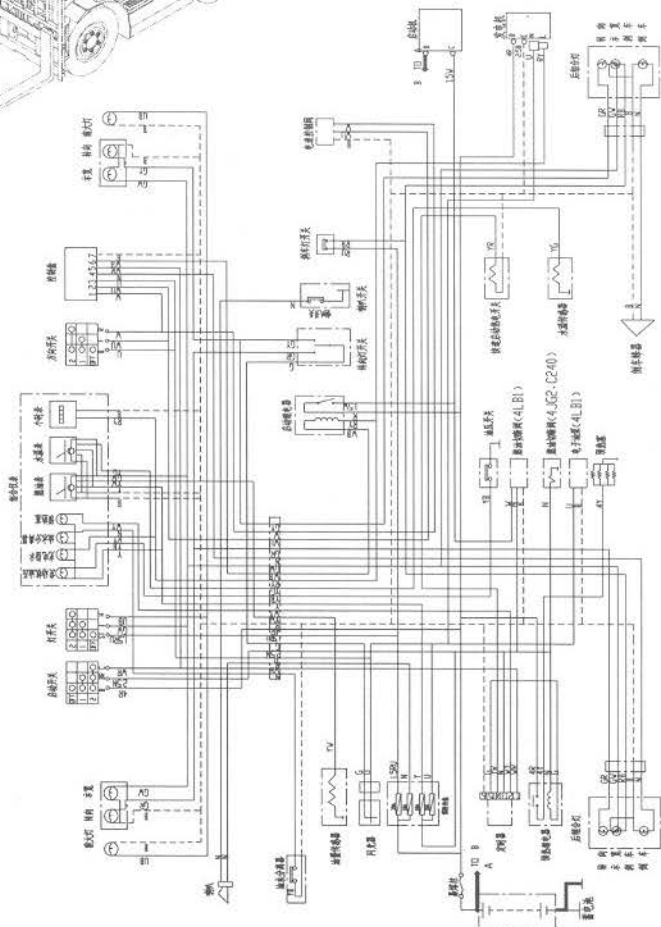
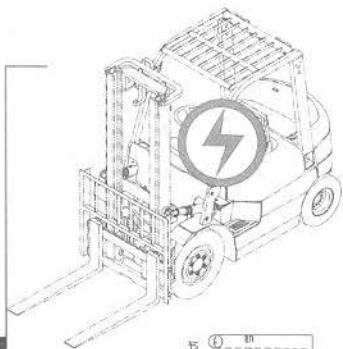

序号 Item No	图号 Part No	零部件名称 Description	件数 Q'ty	备注 Remark
30	Z8730-0802A	Switch,turn signal 转向灯开关	1	JK802A
31	Z8600-120WD	Head lamp 前大灯	2	WD115x80-FC-1L
32	Z8610-12000	Front combination lamp 前组合灯	2	XH7-1L
33	Z8620-12000	Rear combination lamp 后组合灯	2	XH8-1L
34	A22A2-42000a	Mat 后组合灯垫	2	
35	Z8740-0231D	Brake switch 脚制动开关	1	Jk205
36	D07SG152	Flasher unit 闪光器SG152	1	SG152
37	B1010-06010	Screw 螺钉M6x10	1	GB65-85
38	B5050-00006	Washer,lock 垫圈6	1	GB93-87
39	B5210-00006	Washer 垫圈6	1	GB96-85
40	H24C2-40491	Caution light 警示灯	1	选用
41	H24C2-40431	Wire harness,caution light 警示灯线束	2	选用
42	H24C2-40901	Backsight mirror 后视镜	1	选用
43	D09JK211	Light switch 灯开关	1	JK211

图50/FIG50

H2000型组合仪表总成/COMBINATION M/T, H2000 TYPE

B10

序号 Item No	图号 Part No	零部件名称 Description	件数 Q'ty	备注 Remark
A	Z8498-ZB103	Combination M/T H2000型组合仪表总成	1	除CPC(D)20~35-HJ 外柴油车
-	Z8498-ZB103S	Combination M/T H2000型组合仪表总成	1	CPQ,CPQD20~35
-	P62B2-40201	Combination M/T H2000型组合仪表总成	1	CPC(D)20~35-HJ
01	XL8.840.001	Cover 面罩	1	
02	XL8.846.001	Shuck 外壳	1	
03	XL5.944.003	Stopwatch 小时表	1	
04	XL8.803.001	Front-panel 面板	1	
05	XL5.944.002	Indicator, temperature 水温表指示器	1	除CPC(D)20~35-HJ 外柴油车
-	XL5.944.020	Indicator, temperature 水温表指示器	1	CPQ,CPQD20~35
-	XL5.944.021	Indicator, temperature 水温表指示器	1	CPC(D)20~35-HJ
06	XL5.944.001	Indicator, fuel 燃油表指示器	1	
07	XL8.088.003	Circuit board 线路板	1	
08	PL1.2	Bulb 灯泡	8	
09	DJ7082-6.3-11	Jacket, 8-wire plug 八线插头护套	1	
10	DJ7062-6.3-11	Jacket, 6-wire plug 六线插头护套	1	

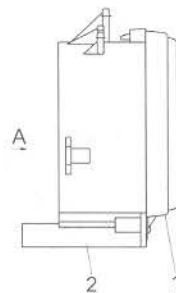
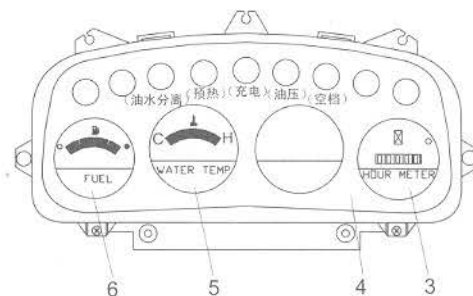
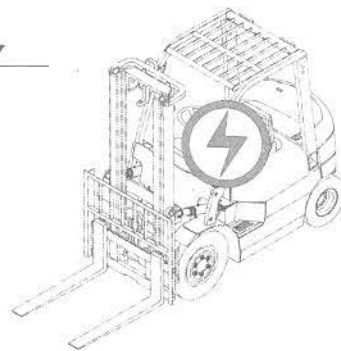
CPQ,CPQD20,25,30,35
CPC,CPCD20,25,30,35

A向

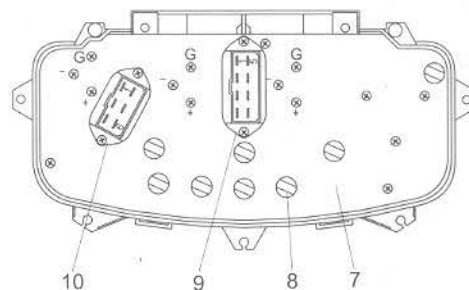

B

B11

H2001型组合仪表总成/COMBINATION M/T, H2001 TYPE

图51/FIG51

CPQ, CPQD20, 25, 30, 35
CPC, CPCD20, 25, 30, 35

序号 Item No	图号 Part No	零件名称 Description	件数 Qty	备注 Remark
A	H24C2-40511	Combination M/T	H2001型组合仪表	1 除日产汽油机用
-	H24C2-40521	Combination M/T	H2001型组合仪表	11 仅日产汽油机用
01	H2001-20	Cover	面罩	1
02	H2001-10	Shuck	外壳	1
03	H2001-11	Front-panel	面板	1
04	H2001-13/ H2001.PCB	Circuit board & meter core	线路板与表芯总成	1 除日产汽油机用
-	H2001-13/ H2001.PCB	Circuit board & meter core	线路板与表芯总成	1 仅日产汽油机用
05	PL1.2	Bulb	灯泡	4
06	DJ7082-6.3-11	Jacket, 8-wire plug	八线插头护套	1
07	DJ7062-6.3-11	Jacket, 6-wire plug	六线插头护套	1



图52/FIG52

ZB908型组合仪表 / COMBINATION M/T, ZB908 TYPE

B12

序号 Item No	图号 Part No	零部件名称 Description	件数 Q'ty	备注 Remark
A	D04ZB908GZ	Combination M/T	组合仪表	1 CPQ(D)20-35-ZJ3
-	D04ZB908JH	Combination M/T	组合仪表	1 XL3.926.030 CPC(D)20-35-HJ.D CPC(D)20-35-ZJ2
-	D04ZB908	Combination M/T	组合仪表	1 CPC(D)20-30-Ku1
01	XL8.804.057	Temperature meter	水温表盘	1
02	XL7.824.037	Circuit board & meter core	线路板与表芯总成	1 除CPC(D)20-30-Ku1外
-	XL7.824.035	Circuit board & meter core	线路板与表芯总成	1 CPC(D)20-30-Ku1
03	XL8.804.058	Fuel meter	燃油表盘	1
04	XL8.840.001	Cover	面罩	1
05	XL8.846.001	Shunk	外壳	1
06	XL8.846.030	Rear cover	后盖板	1
07	XL8.804.060	Type sign	型号标识	1
08	DJ7161-2.3-20	16-wire socket	16线插座	1
09	XL8.804.059	Lamp	故障诊断指示灯	1 CPQ(D)20-35-ZJ3

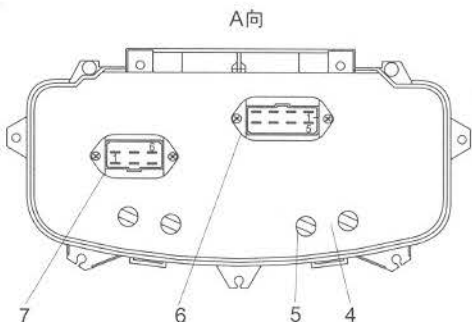
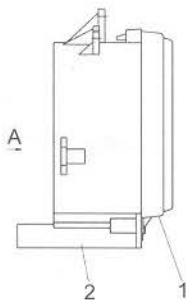
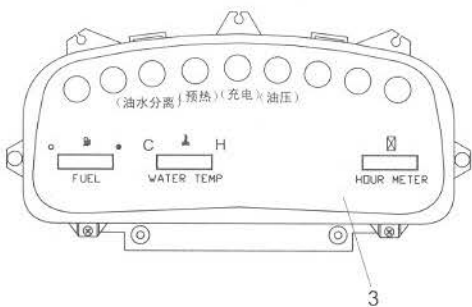
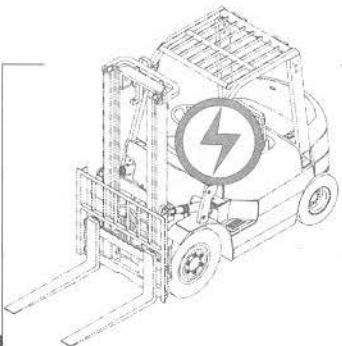
CPC, CPCD20, 25, 30, 35-HJ, D, Ku1
CPQ, CPQD20, 25, 30, 35-ZJ2, ZJ3

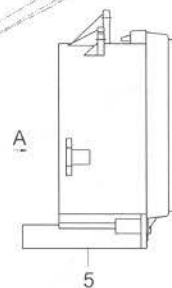
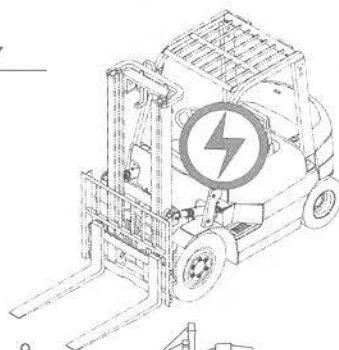
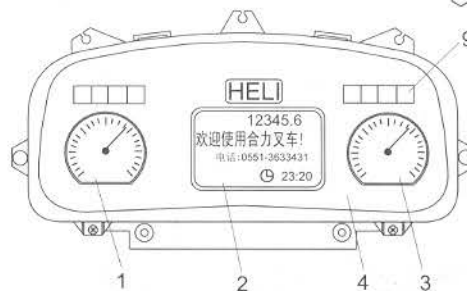

A向

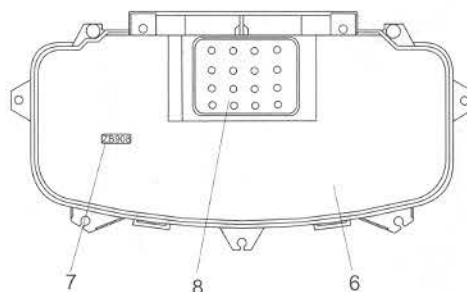

B

CPC,CPCD20,25,30-KU1

序号 Item No	图号 Part No	零件名称 Description	件数 Q'ty	备注 Remark
01	JQK1	Relay 时间继电器	1	
02	D07SG152	Flasher unit 闪光器SG152	1	
03	D06BX2081	Fuse box 保险丝盒	1	
04	JQ1030/04	Warm-up relay 继电器	1	
05	JQ1030/04	Start-up relay 继电器	1	用于启动继电器
06	H2B16-41201	Board,electric element 电气板总成		

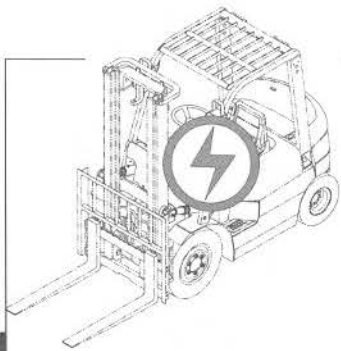

B

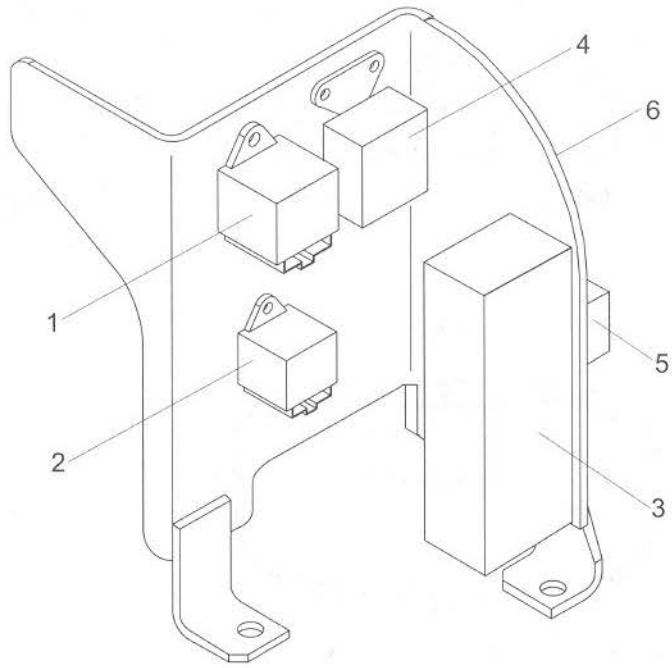

序号 Item No	图号 Part No	零部件名称 Description	件数 Q'ty	备注 Remark
01	D06BX2081	Fuse box 保险丝盒	1	
02	Z8340-1H202	Relay 继电器	1	
03	JQ1030/04	Startup relay 启动继电器	1	
04	D07SG152	Flasher unit 闪光器	1	
05	H24C6-41303	Board,electric element 电气元件板	1	

CPQ,CPQD20,25,30,35

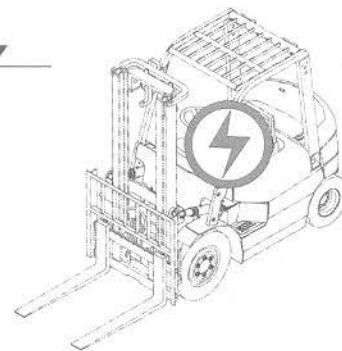

B

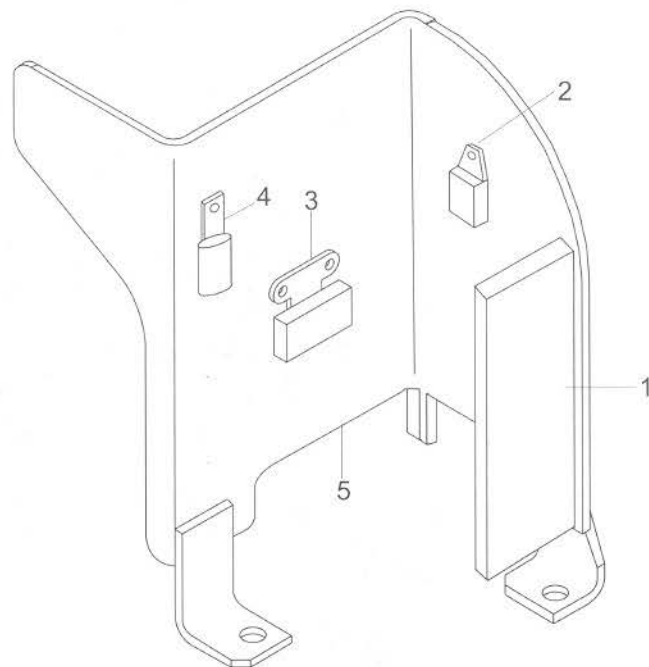

CPC, CPCD20, 25, 30-X6
CPC, CPCD35-X2

序号 Item No	图号 Part No	零部件名称 Description	件数 Q'ty	备注 Remark
01	D06BX2081	Fuse box	1	保险丝盒
02	JQ1030/04	Relay	2	继电器
03	Z8300-10147	Adjustment	1	电压调节器
04	D07SG152	Flasher unit	1	闪光器
05	H93C6-40301	Board, electric element	1	电气板总成
06	JQK1	Relay	1	时间继电器

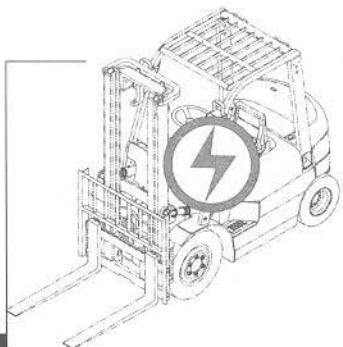
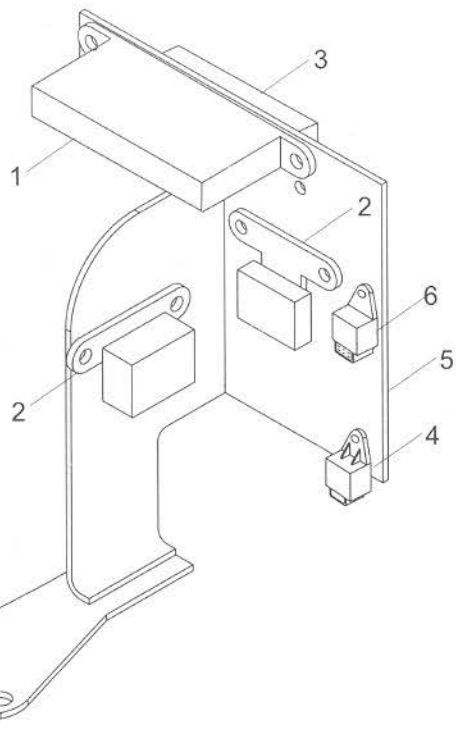

序号 Item No	图号 Part No	零部件名称 Description	件数 Q'ty	备注 Remark
01	H25S6-41303	Board,electric element 电气元件板	1	
02	D06BX2081	Fuse box 保险丝盒	1	
03	Z8900-12Q0S	Timer 定时器	1	进口柴油机 进口件21152-42012
-	JQK1	Relay 时间继电器	1	CPC(D)20~35-D
04	JQ1030/04	Startup relay 启动继电器	1	
05	Z8930-10000	Relay 继电器	1	进口柴油机 进口件21152-42021
-	JQ1030/04	Relay 预热继电器	1	CPC(D)20~35-D
06	D07SG152	Flasher unit 闪光器	1	

CPC,CPCD20,25,30-W7,W8,W9
CPC,CPCD20,25,30-D
CPC,CPCD35-W4,W5,W6,D

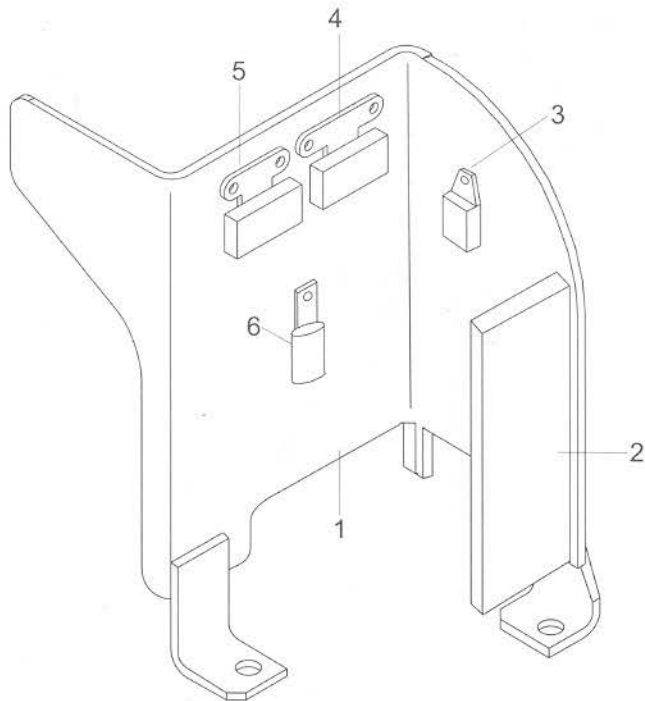
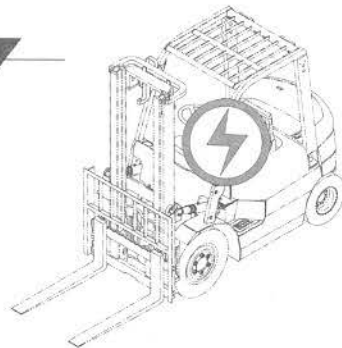

CPC, CPCD20, 25, 30, 35-HJ

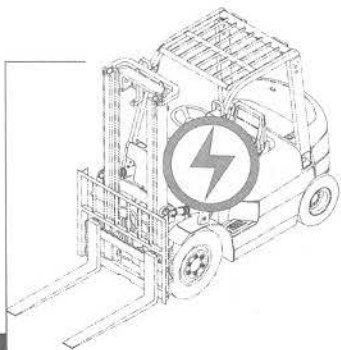

序号 Item No	图号 Part No	零部件名称 Description	件数 Q'ty	备注 Remark
01	D06BX2083	Fuse box	保险丝盒 1	
02	JQK1	Relay	时间继电器 1	
03	JQ1030/04	Startup relay	启动继电器 1	
04	D07SG152	Flasher unit	闪光灯 1	
05	H97Y6-42001	Board, elector element	电气板总成 1	
06	JQ1030/04	Warm-up relay	预热继电器 1	
07	5-82550-029-0	Cold boot	冷启动继电器 1	



图58/FIG58

传动装置安装(液力式)/DRIVE UNIT MOUNT (TOR-CON TYPE)

C1

序号 Item No	图号 Part No	零部件名称 Description	件数 Q'ty	备注 Remark
01	HRH25S3801	Drive unit 液力变速箱	1	
02	B5050-00012	Washer, lock 垫圈12	12	GB93-87
03	B0422-12040	Bolt 螺栓M12×1.25×40	12	GB5785-86
04	B4125-00010	Nut 螺母M10	1	GB6170-86
05	B5211-00010	Washer, 垫圈10	1	GB96-85
06	B0222-10060	Bolt 螺栓M10×60	1	GB5782-86
07	B5050-00010	Washer, lock 垫圈10	8	GB93-87
08	B0422-10035	Bolt 螺栓M10×1.25×35	7	GB5785-86
09	55593-52161G	Clip 管夹片	1	
10	24452-52001	Packing 垫片	1	

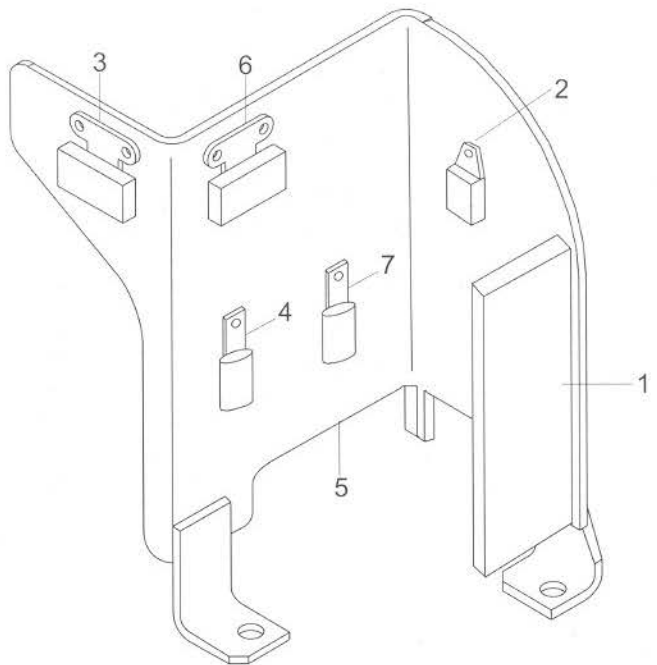
CPQD20,25,30,35
 CPCD20,25,30-W7,W8,W9,Xs1,HJ,Ku1
 CPCD35-W4,W5,W6,Xs1,HJ

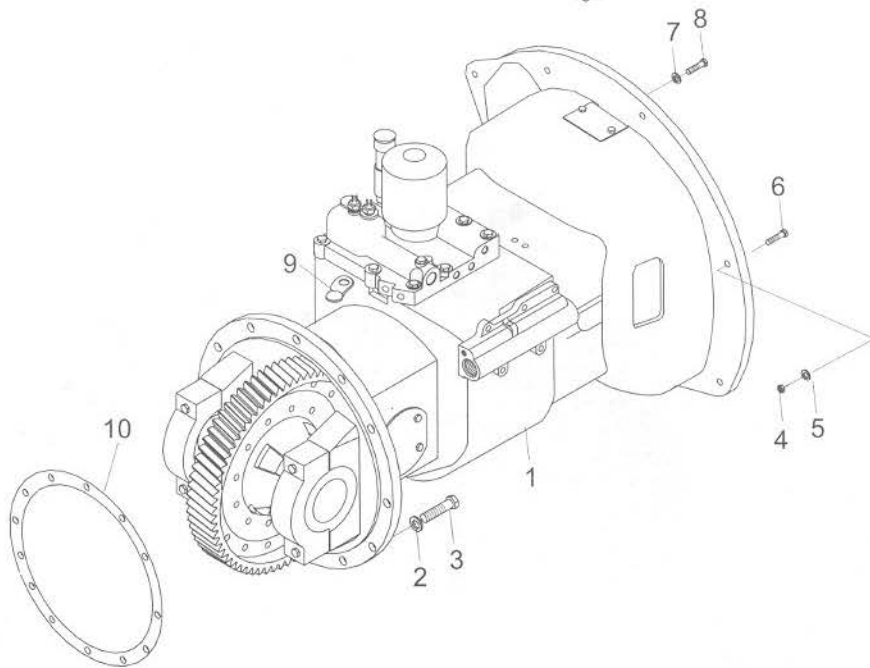
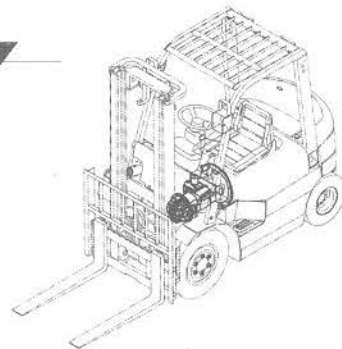

CPCD20,25,30-X6,D
CPCD35-X2,D

序号 Item No	图号 Part No	零部件名称 Description	件数 Qty	备注 Remark
01	A29B2-50201	Drive unit 液力变速箱总成	1	机械换挡
-	H93D2-50201	Drive unit 液力变速箱总成	1	电液换挡
02	B5050-00012	Washer, lock 垫圈12	12	GB93-87
03	B0430-12040	Bolt 螺栓M12 × 1.25 × 40	12	GB5785-86
04	B5050-00010	Washer, lock 垫圈10	9	GB93-87
05	B0230-10035	Bolt 螺栓M10 × 35	9	GB5782-86
06	24452-52001	Packing 垫片	1	



图60/FIG60

传动装置(液力式)/DRIVE UNIT (TOR-CON TYPE)

C3

序号 Item No	图号 Part No	零部件名称 Description	件数 Qty	备注 Remark
01	H25S3-82001	Case, tor-con	1	进口发动机 CPCD20-35-HJ
-	22502-52113G	Case, tor-con	1	其余国产柴油机
-	H94N2-50211	Case, tor-con	1	CPQD20-35-ZJ2,ZJ3
02	12163-82232	Cup	1	加油口盖
03	H25S3-84001	Plug	1	螺塞总成
04	H25S3-20001	Tor-con ass'y	1	进口发动机 CPCD20-35-HJ,ZJ2,ZJ3,Ku1
-	12163-80301G	Tor-con ass'y	1	其余国产发动机
05	15583-80221	Charging pump ass'y	1	供油泵总成 See Fig. 63
06	15583-82201	Gasket	1	衬垫
07	B6150-00035	Snap ring	1	挡圈35 GB894-86
08	12163-82531	Strainer	1	滤油器(1)
09	Z6004-03503	O-ring	1	O形圈35X3.1 GB1235-76
10	G0121-00011	Plug	2	内六角螺塞1/4"
11	Z6004-02804	O-ring	1	O形圈28X3.5 GB1235-76
12	11243-82501	Gasket	1	垫片
13	B0330-10075	Bolt	1	螺栓M10X75 GB5783-86
14	B0330-10055	Bolt	3	螺栓M10X55 GB5783-86
15	B0330-10050	Bolt	1	螺栓M10X50 GB5783-86
16	B0330-10030	Bolt	4	螺栓M10X30 GB5783-86
17	B5050-00010	Washer	15	垫圈10 GB93-87
18	B3120-12020	Pin	2	销B12X20 GB119-76
19	Z6004-01502	O-ring	1	O形圈15X2.4 GB1235-76
20	120M3-82011	Case, mission	1	壳体
21	14453-22031	Cap,bearing	2	轴承座
22	15413-22021	Bolt	4	螺栓
23	14453-52111	Plate, lock	4	锁片
24	14883-80201	Clutch, hydraulic	1	离合器总成 See Fig. 64
25	12163-42201	Shaft, idler	1	惰轮轴
26	Z-6206-2RS	Bearing	1	轴承6206-2RS GB/T276-94
27	12163-42211	Gear, kdler	1	惰轮

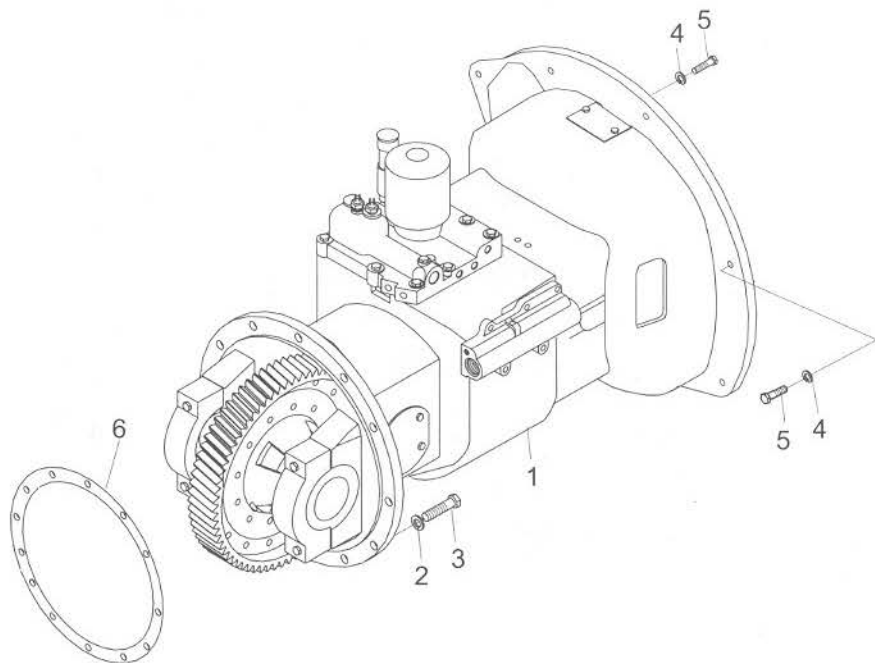
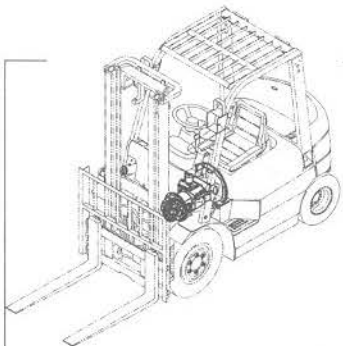
CPCD,CPQD20,25,30,35

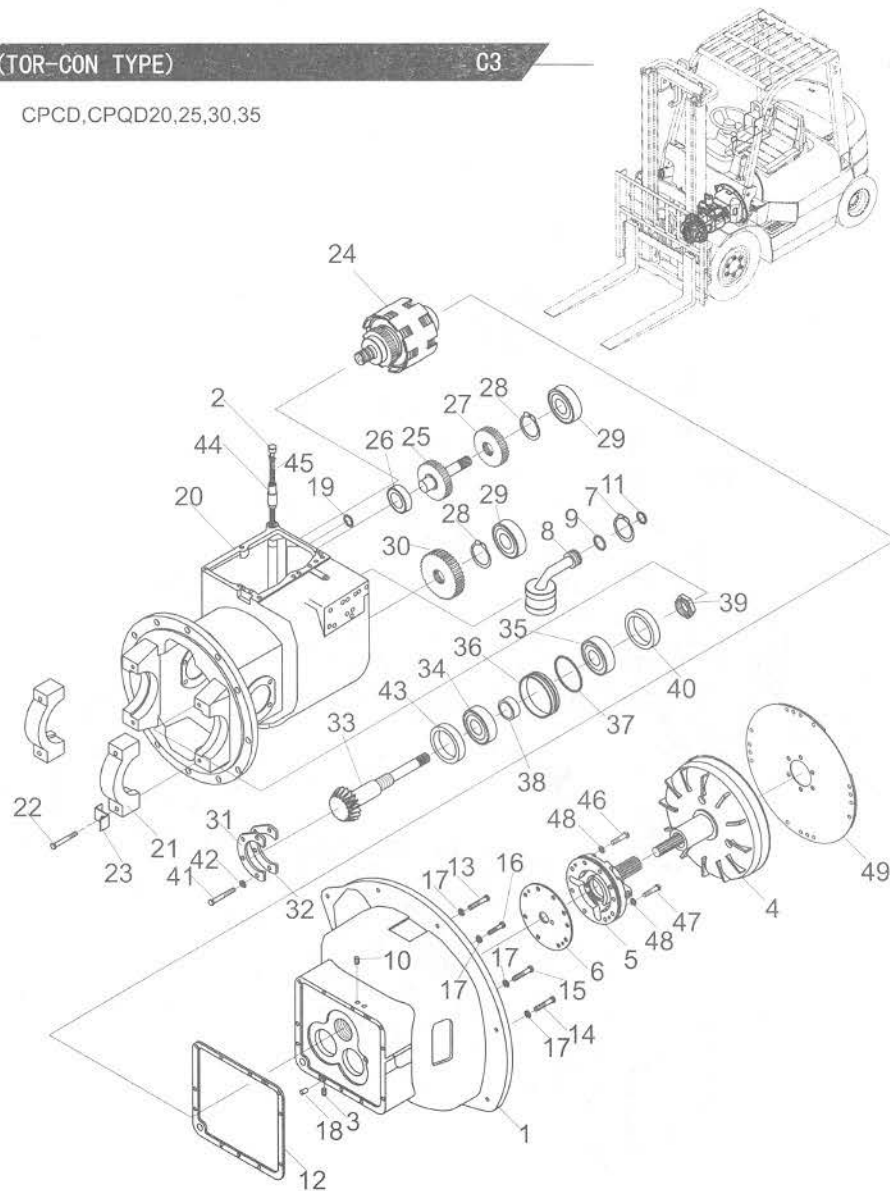

CPCD,CPQD20,25,30,35

序号
Item
No图号
Part No零部件名称
Description件数
Q'ty备注
Remark

28	B6050-00024	Snap ring	挡圈24	2	GB893-86
29	Z-6207	Bearing	轴承6207	2	GB/T276-94
30	12163-42231	Gear, output	输出齿轮	1	
31	12163-82151	Plate, bearing support	支承片	1	
32	12163-82571	Shim	垫片	AR	
-	12163-82581	Shim	垫片	AR	
-	12163-82591	Shim	垫片	AR	
33	14463-42001	Shaft, output	输出轴	1	
34	Z-32208	Bearing	轴承32208	2	GB/T294-94
35	Z-30208	Bearing	轴承30208	1	GB/T294-94
36	12163-82121	Retainer, oil seal	油封保持架	1	
37	Z6003-08003	O-ring	O形圈80×3.1	1	GB1235-76
38	12163-82131	Seal, oil	油封	1	
39	11243-82621	Nut	螺母	1	
40	12163-82501	Shim	垫	AR	
-	12163-82511	Shim	垫	AR	
-	12163-82521	Shim	垫	AR	
-	12163-82551	Shim	垫	AR	
41	B0330-08020	Bolt	螺栓M8×20	4	GB5783-86
42	B5050-00008	Washer	垫圈8	4	GB93-87
43	12163-82191	Collar	轴环	1	
44	12163-82221	Pipe oil fill	加油管	1	
45	12163-82421	Gasket	衬垫	1	
46	B0330-08045	Bolt	螺栓M8X45	4	GB5783-86
47	B0330-08035	Bolt	螺栓M8X35	2	GB5783-86
48	12163-82561	Gasket	衬垫	6	
49	13683-82021	Plate	弹性板	1	



图61/FIG61 传动装置(盖和微动阀 机液控制)/DRIVE UNIT(COVER & INCHING VALVE MACHINE-HYDRAULIC) C4

序号 Item No	图号 Part No	零部件名称 Description	件数 Qty	备注 Remark
01	11243-82272	Cover, case	壳体盖 1	
02	11243-82291	Arm, shift	变速臂 1	
03	B3352-06032	Pin, lock	销6×32 1	GB879-76
04	11243-82281	Shaft, shift arm	变速臂轴 1	
05	Z6004-02002	O-ring	O形圈20×2.4 1	GB1235-76
06	Z4000-05019	Key, woodruf	半圆键5×19 1	GB1099-79
07	12163-82291	Bolt	螺栓 1	
08	12163-82561	Shim	衬垫 1	
09	12163-82431	Plug	塞子 1	
10	12003-42451	Switch	倒车灯开关 2	
11	12003-42461	Shim	衬垫 2	
12	12163-82311	Nipple	管接头 1	
13	12163-82301	Filter, oil	滤油器(II) 1	
14	B3352-04026	Pin, lock	弹性圆柱销4×26 1	GB879-76
15	12163-82321	Piston	活塞 1	
16	12163-82331	Spring	弹簧 1	
17	12163-82341	Cup	安全阀盖 1	
18	12163-82421	Packing, copper	衬垫 1	
19	G0121-00021	Plug	螺塞1/8" 6	
20	G0121-00011	Plug	螺塞1/4" 4	
21	HRH25S3802 15583-80211	Control ass'y	控制阀总成 1	See Fig.65
22	15583-82483	Gasket	垫片 1	
23	B0330-08035	Bolt	螺栓M8×35 2	GB5783-86
24	B0330-08055	Bolt	螺栓M8×55 2	GB5783-86
25	B0330-08050	Bolt	螺栓M8×50 4	GB5783-86
26	B5050-00008	Shim	垫圈8 11	GB93-87
27	11243-82531	Gasket	垫片 1	
28	Z6003-00901	O-ring	O形圈9×1.9 2	GB1235-76
29	B5050-00010	Washer,lock	垫圈10 8	GB93-87
30	B0330-10055	Bolt	螺栓M10×55 2	GB5783-86

CPCD,CPQD20,25,30,35

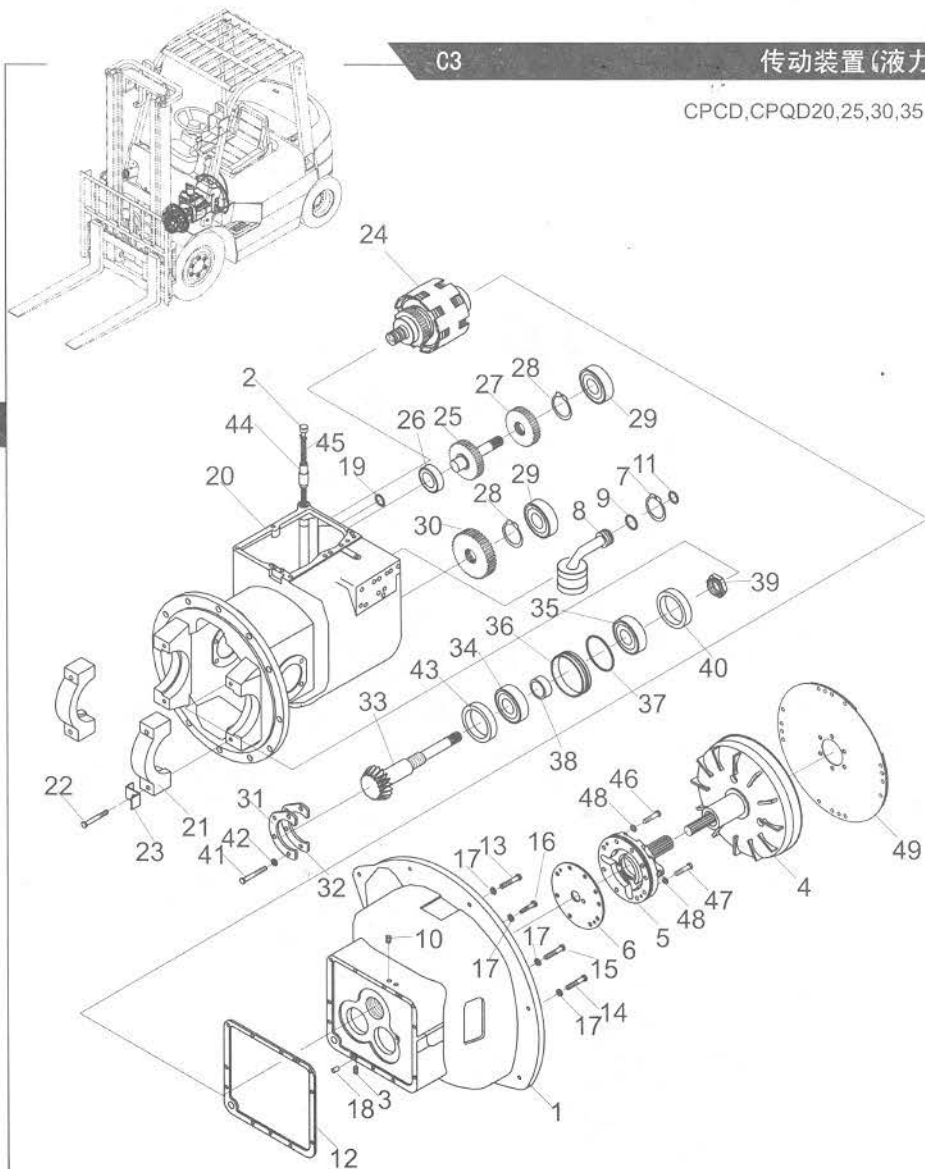
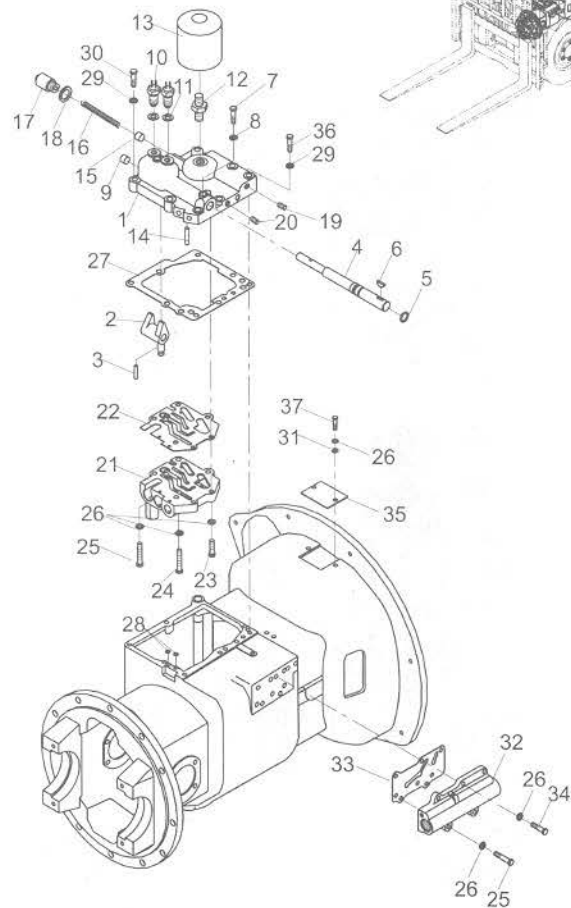

C4 传动装置(盖和微动阀 机液控制)/DRIVE UNIT (COVER & INCHING VALVE MACHINE-HYDRAULIC) 图61/FIG61

CPCD,CPQD20,25,30,35

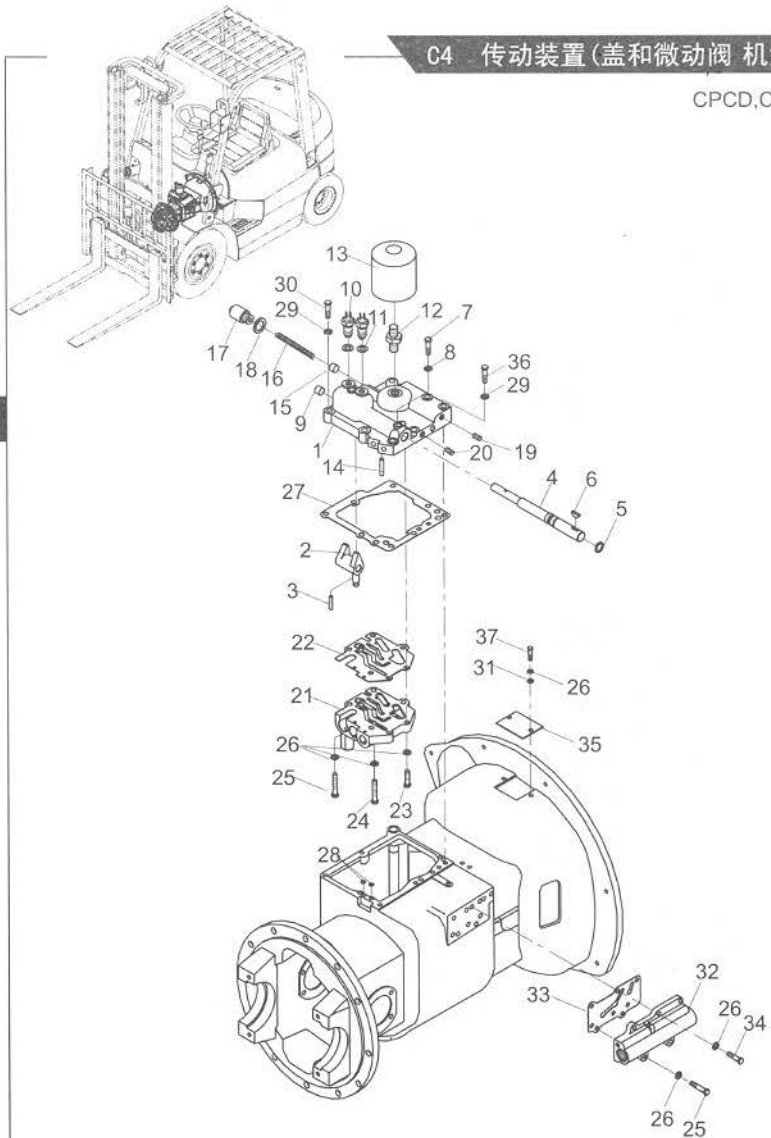

序号 Item No	图号 Part No	零部件名称 Description	件数 Q'ty	备注 Remark
31	B5310-00008	Shim	垫圈8	2 GB97.1-85
32	15583-80202	Inching value ass'y	微动阀总成	1 See Fig.66
33	15583-82081	Shim	衬垫	1
34	B0330-08025	Bolt	螺栓M8X25	3 GB5783-86
35	15583-83611	Cover, tor-con	变矩器盖	1
36	B0330-10040	Bolt	螺栓M10X40	6 GB5783-86
37	B0330-08012	Bolt	螺栓M8X12	2 GB5783-86

图62/FIG62 传动装置(盖和微动阀 电液控制)/DRIVE UNIT(COVER & INCHING VALVE ELECTRIC-HYDRAULIC) C5

序号 Item No	图号 Part No	零部件名称 Description	件数 Q'ty	备注 Remark
01	116H3-82301	Cover, case	壳体盖 1	
02	34E-10BY-12	Valve, solenoid	电磁阀 1	
03	115G3-82141	Pin	销 1	
04	B0330-10055	Bolt	螺栓M10X55 2	GB5783-86
05	B5310-00008	Shim	垫圈8 2	GB97.1-85
06	15583-80202	Inching valve ass'y	微动阀总成 1	See Fig.66
07	15583-82081	Shim	衬垫 1	
08	B0330-08025	Bolt	螺栓M8X25 4	GB5783-86
09	15583-83611	Cover, tor-con	变矩器盖 1	
10	B0330-10040	Bolt	螺栓M10X40 6	GB5783-86
11	B0330-08012	Bolt	螺栓M8X12 2	GB5783-86
12	12163-82311	Nipple	管接头 1	
13	12163-82301	Filter, oil	滤油器 1	
14	B8030-05045	Screw	螺钉M5x45 4	
15	12163-82321	Piston	活塞 1	
16	12163-82331	Spring	弹簧 1	
17	12163-82341	Cup	安全阀盖 1	
18	12163-82421	Packing, copper	衬垫 1	
19	G0121-00021	Plug	螺塞1/8" 4	
20	G0121-00011	Plug	螺塞1/4" 7	
21	HRH25S3802 15583-80211	Control ass'y	控制阀总成 1	See Fig.65
22	15583-82481	Gasket	垫片 1	
23	B0330-08035	Bolt	螺栓M8 × 35 4	GB5783-86
24	B0330-08055	Bolt	螺栓M8 × 55 2	GB5783-86
25	B0330-08050	Bolt	螺栓M8 × 50 4	GB5783-86
26	B5050-00008	Shim	垫圈8 11	GB93-87
27	11243-82531A	Gasket	垫片 1	
28	Z6003-00901	O-ring	O形圈9 × 1.9 2	GB1235-76
29	B5050-00010	Washer, lock	垫圈10 8	GB93-87

CPCD, CPQD20, 25, 30, 35

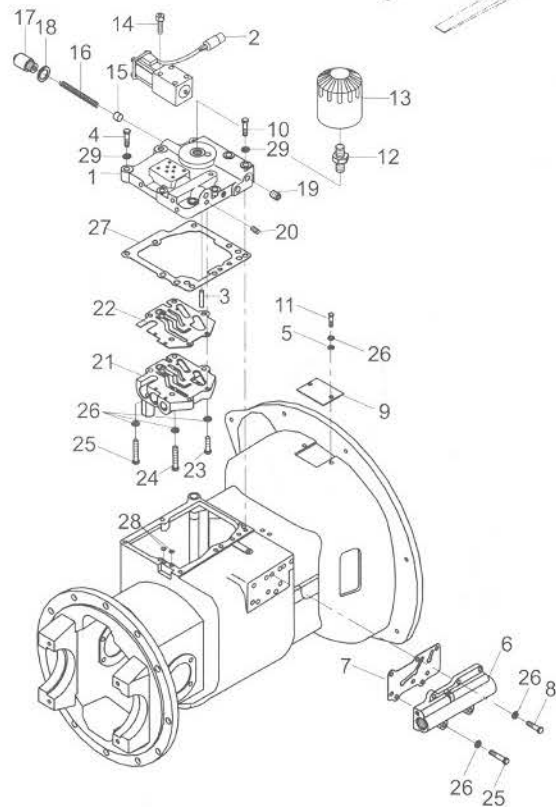
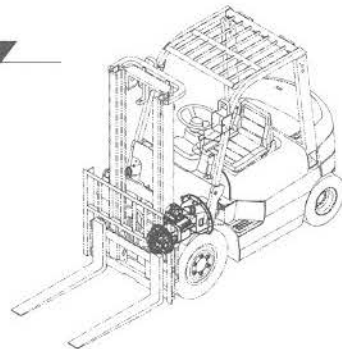

C

CPCD,CPQD20,25,30,35

序号
Item
No图号
Part No零部件名称
Description件数
Q'ty备注
Remark

序号 Item No	图号 Part No	零部件名称 Description	件数 Q'ty	备注 Remark
A	15583-80221	Charging Pump ass'y	1	供油泵总成
01	15583-82151	Case, Pump	1	泵体
02	15583-82161	Bushing	1	衬套
03	12163-82561	Washer	2	衬垫
04	15583-82171	Seal, oil	1	油封
05	15583-82181	Snap O- ring	1	"O"形密封圈
06	15583-82192	Support, starter	1	锭子
07	B2212-06016	Pin	2	圆柱销6X16
08	15583-82231	Gear, drive	1	主动齿轮
09	15583-82241	Bushing	1	衬套
10	15583-82251	Gear, driven	1	被动齿轮
11	B0330-08025	Bolt	1	螺栓M8X25
12	B0330-08035	Bolt	1	螺栓M8X35

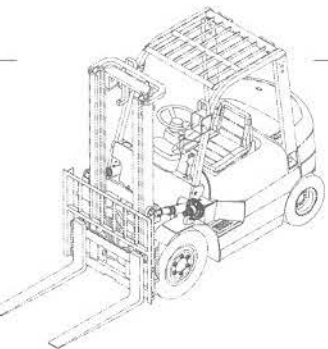

C



图64/FIG 64

液力离合器 (液力式) /HYDRAULIC CLUTCH(TOR-CON TYPE)

C7

序号 Item No	图号 Part No	零部件名称 Description	件数 Q'ty	备注 Remark
A	14883-80201	Clutch, hydraulic	离合器总成	1
01	11243-80211	Shift, input	输入轴总成	1
02	11243-82061	Gear, reverse	倒车档齿轮	1
03	11243-82051	Gear, forward	前进档齿轮	1
04	11243-82221	Plate, end	端板	2
05	11243-82081	Spring, return	回程弹簧	2
06	11243-82091	Seat, spring	弹簧座	2
07	11243-82101	Ring, thrust	止推环A	2
08	11243-82111	Ring, thrust	止推环B	2
09	11243-82041	Piston	活塞	1
10	11243-82121	Plug	塞	1
11	Z1520-01008	Ball, steel	钢球1/8"	1 GB307-77
12	11243-82141	Plate, friction	摩擦片	8
13	11243-82151	Plate, separator	隔片	8
14	11243-82161	Ring, seal	密封环A	4
15	11243-82171	Ring, seal	密封环B	2
16	Z6003-04004	O-ring	O形圈33.7×3.5	2 GB1235-76
17	11243-82181	Snap, ring	卡环	2
18	Z-206	Bearing	轴承206	2 GB276-82
19	11243-82201	Bearing, needle	滚针轴承	2
20	B6152-00040	Snap, ring	挡圈40	2 GB894-86
21	B8330-08008	Plug	螺钉M8×8	2 GB78-85

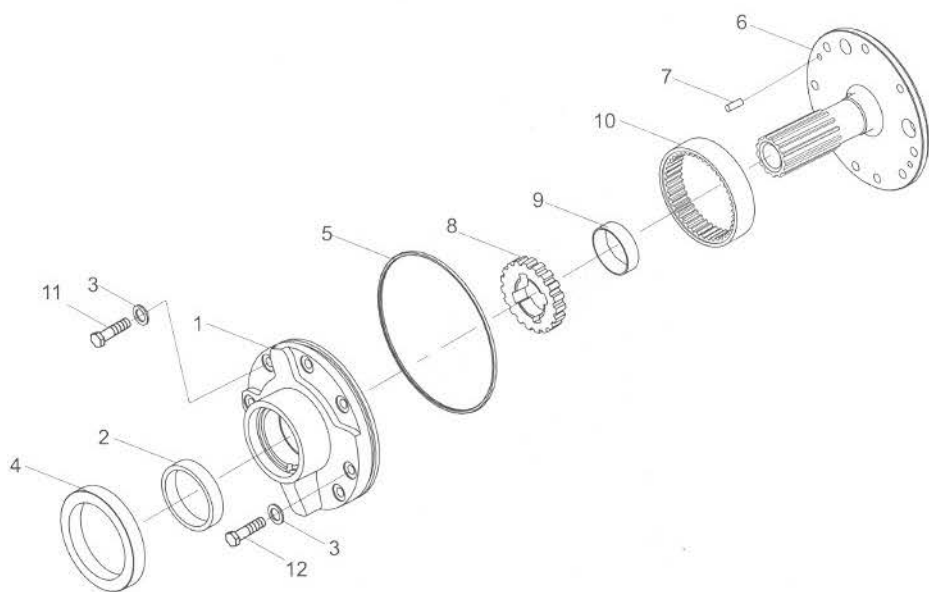
CPCD,CPQD20,25,30,35

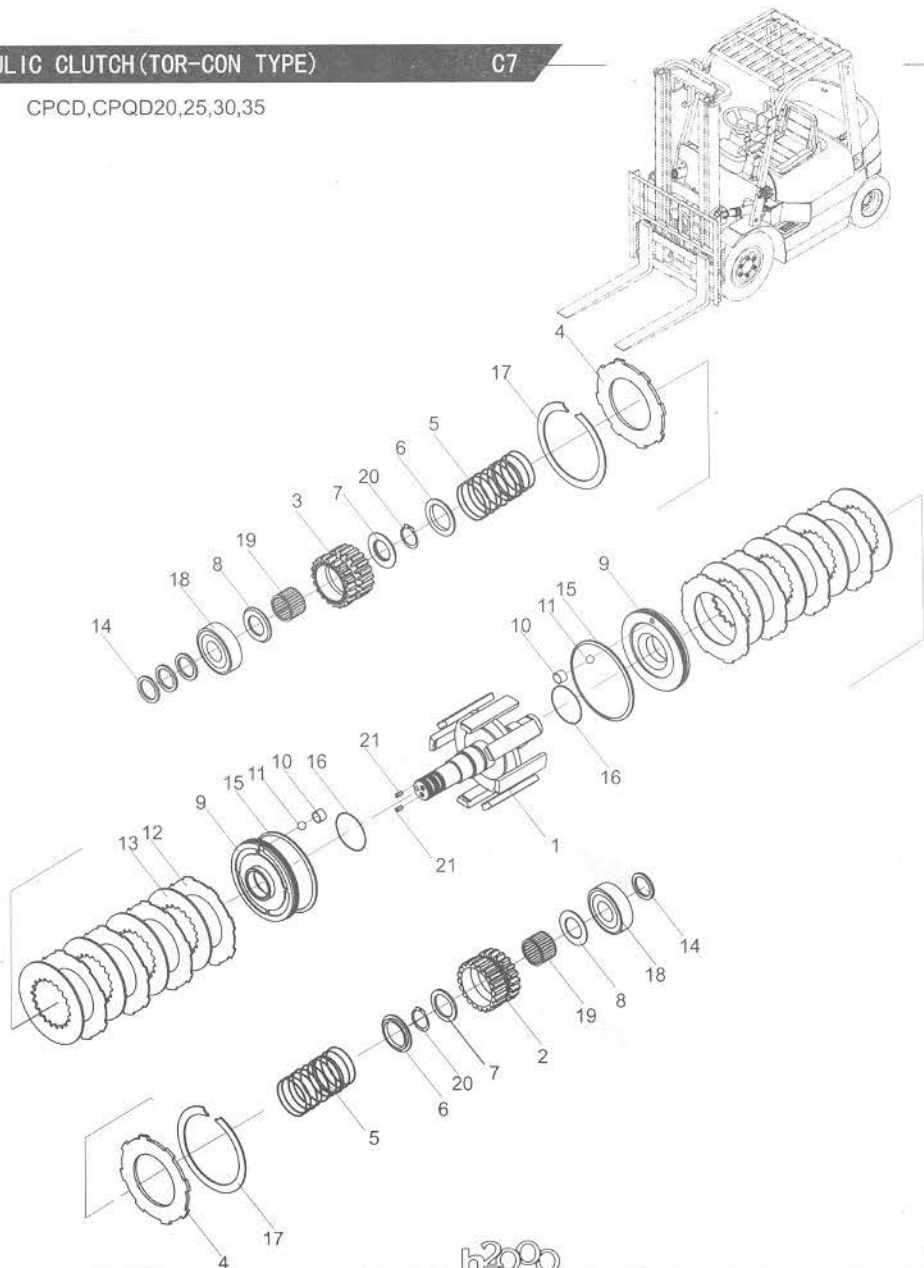

CPCD, CPQD20, 25, 30, 35

序号 Item No	图号 Part No	零部件名称 Description	件数 Q'ty	备注 Remark
A	15583-80211	Control valve ass'y	控制阀总成	1
01	15583-82362	Body, valve	阀体	1
02	15583-82371	Spool	滑阀	1
03	15583-82381	Plug	油塞	1
04	15583-82391	Spring	弹簧	1
05	03190-00013	Ball	钢球13/32"	1 GB308-89
06	15583-82402	Piston	活塞	1
07	15583-82411	Spring	弹簧	1
08	15583-82421	Spring	弹簧	1
09	15583-82431	Plug	塞	1
10	B3352-04035	Pin, lock	销4X35	1 GB879-76
11	15583-82441	Spool	卷轴	1
12	15583-82451	Spring	弹簧	1
13	15583-82461	Spring	弹簧	1
14	15583-82471	Plug	塞	1
15	B3352-04040	Pin, lock	销4X40	1 GB879-76



图66/FIG66

微动阀(液力式)/INCHING VALVE(TOR-CON TYPE)

C9

序号 Item No	图号 Part No	零部件名称 Description	件数 Q'ty	备注 Remark
A	15583-80202	Inching valve ass'y	1	微动阀总成
01	B6052-00030	Snap ring	1	挡圈30 GB893.1-86
02	15583-82002	Body, valve	1	阀体
03	15583-82012	Spool	1	卷杆
04	15583-82022	Plunger	1	滑阀
05	Z6054-02362	O-ring	1	O形圈23.6×2.65 GB3452.1-92
06	15583-82032	Seal, oil	1	油堵
07	B6050-00028	Snap ring	1	挡圈28 GB893.1-86
08	15583-82052	Spring	1	主弹簧 $\varnothing 1.2 \times D9.2 \times 30$
09	15583-82042	Spring	1	微动弹簧 $\varnothing 3 \times D22.9 \times 87.4$
10	15583-82062	Spacer	1	垫块
11	Z6451-00161	Seal, oil	1	油封 $\varnothing 30 \times \varnothing 16 \times 7$
12	15583-82092	Plug, choke	1	油塞
13	Q/ZB285-77	Plug	2	螺塞Z1/8"

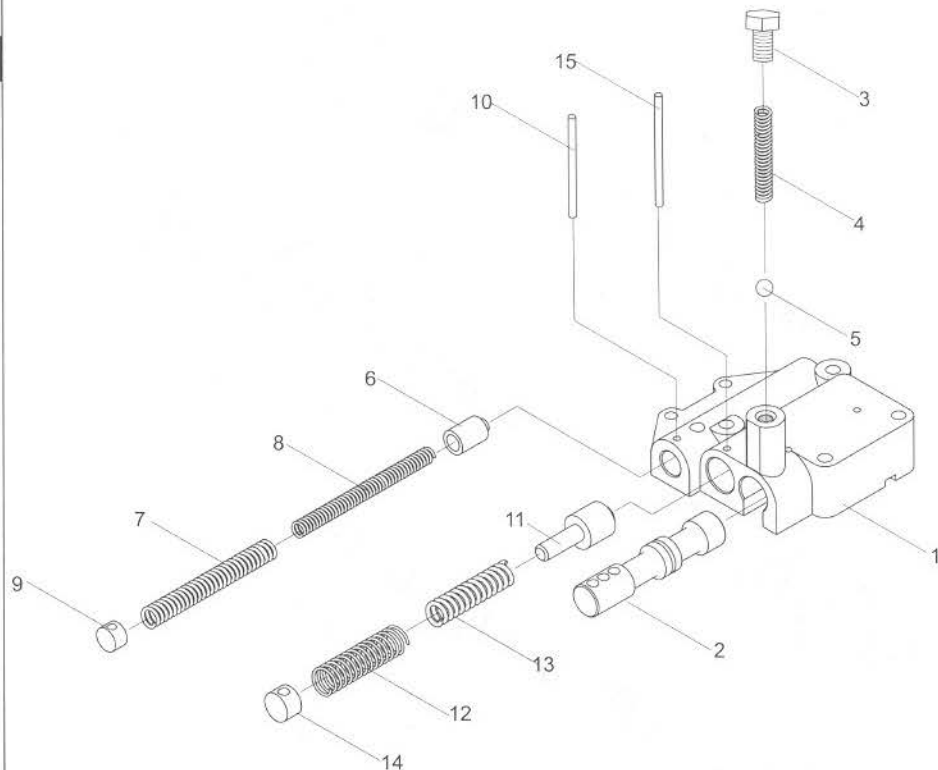
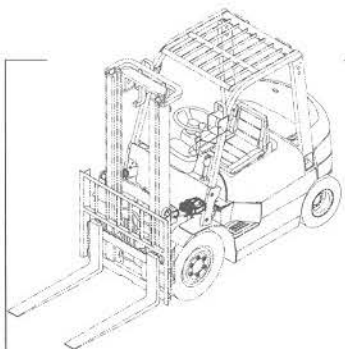
CPCD,CPQD20,25,30,35

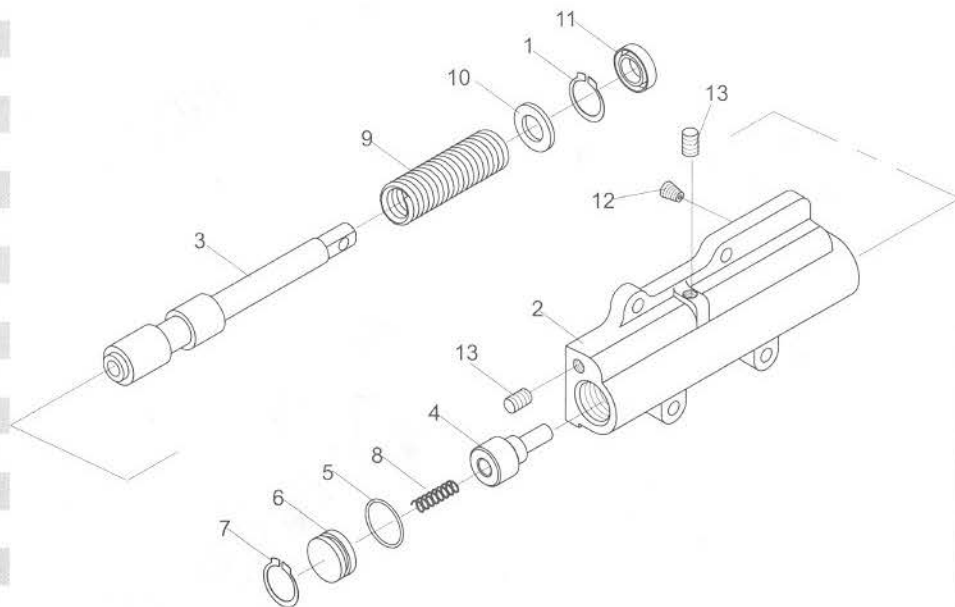
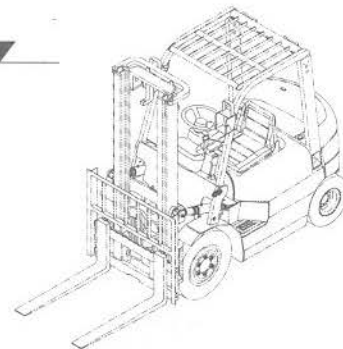

CPC, CPCD20, 25, 30, 35
CPQ, CPQD20, 25, 30, 35

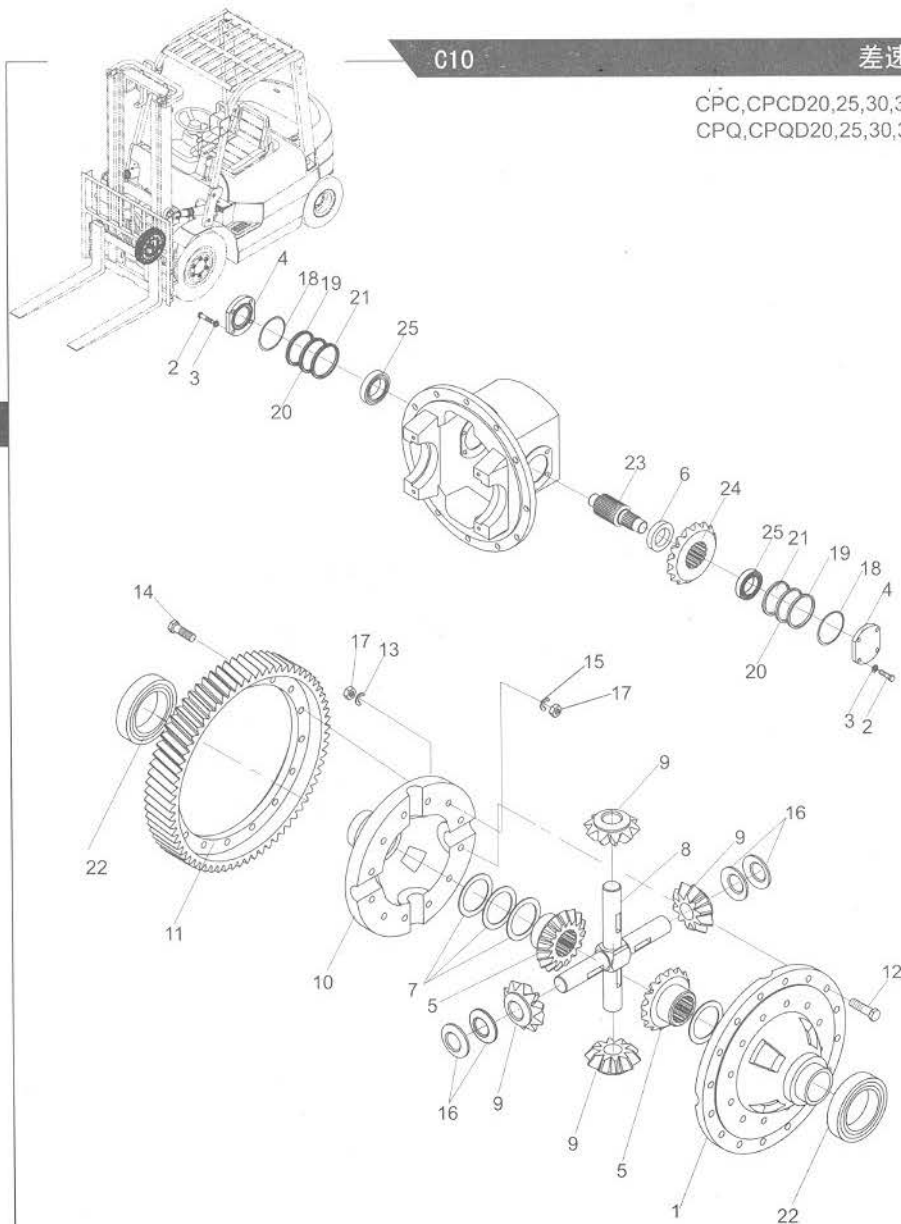

序号 Item No	图号 Part No	零部件名称 Description	件数 Q'ty	备注 Remark
01	14453-52032	Case, cross L.H	左差速器壳体	1
02	B0230-10025	Bolt	螺栓M10×25	8 GB5782-86
03	B5050-00010	Washer	垫圈10	8 GB93-87
04	12003-22051	Cover, bearing	轴承盖	2
05	H24C3-52001	Gear, side	半轴齿轮	2
06	12003-22041	Spacer	衬套	1
07	16113-52141	Washer	垫圈	2
-	14453-52071	Washer	垫圈	2
-	14453-52081	Washer	垫圈	2
08	14453-52101A	Shaft	十字轴	1
09	16113-52112	Gear, pinion	行星齿轮	4
10	14453-52022	Case, cross R.H	右差速器壳体	1
11	14453-52011	Gear, ring	齿圈	1
12	14453-52041	Bolt	螺栓	12
13	14453-52061	Washer, lock	锁片	8
14	14453-52051	Bolt	螺栓	16
15	10113-50141	Plate, lock	锁片	8
16	16113-52121	Washer, thrust	止推垫圈	4
17	B4223-00010	Nut	螺母M10×1.25	28 GB6171-86
18	Z6004-07503	O-ring	O形圈75×3.1	2 GB1235-76
19	15413-22101	Shim	垫片	2
20	15413-22091	Shim	垫片	4
21	15413-22081	Shim	垫片	2
22	Z-213	Bearing	轴承213	2 GB272-93
23	14453-22011	Shaft, final pinion gear	齿轴	1
24	14453-22021	Gear, spiral vevel	螺旋伞齿轮	1
25	12003-43011	Bearing	轴承7507	2

图68/FIG 68

传动装置安装(机械式)/DRIVE UNIT MOUNT (CLUTCH TYPE)

C11

序号 Item No	图号 Part No	零部件名称 Description	件数 Q'ty	备注 Remark
01	H24C3-40201	Drive unit 机械变速箱总成	1	
02	B0422-12040	Bolt 螺栓M12X1.25X40	12	GB5785-86
03	B5052-00012	Washer, lock 垫圈12	12	GB93-87
04	A23A2-50501	Lever, speed change 手柄杆	1	CPC20,25,30,35
-	A22A2-50501	Lever, speed change 手柄杆	1	CPQ20,25,30,35
05	A23A2-50301	Lever, direction change 手柄杆	1	CPC20,25,30,35
-	A22A2-50301	Lever, direction change 手柄杆	1	CPQ20,25,30,35
06	B0530-10035	Bolt 螺栓M10X1.25X35	6	GB5785-86
07	B0222-10050	Bolt 螺栓M10X50	1	GB5782-86 除CPC20-35-Xs1
-	B0430-10070	Bolt 螺栓M10X12.5X70	1	GB5785-86 CPC20-35-Xs1
08	B4125-00010	Nut 螺母M10	1	GB6170-86 除CPC20-35-Xs1
-	B4232-00010	Nut 螺母M10X1.25	1	GB6171-86 CPC20-35-Xs1
09	B5052-00010	Washer, lock 垫圈10	9	GB93-87
10	A22A2-52022	Knob, dirction 变速手柄头	1	
11	A22A2-52002	Knob, speed 换向手柄头	1	
12	129F3-12041	Clutch disc Ass'y 离合器摩擦片总成	1	除CPC20-35-HJ
-	13453-10331	Clutch disc Ass'y 离合器摩擦片总成	1	CPC20-35-HJ
13	B0010-08020	Bolt 螺栓M8X20	6	GB5780-86
14	B5050-00008	Washer, lock 垫圈8	6	GB93-87
15	13553-10301A	Clutch cover 离合器压盘及盖总成	1	除CPC20-35-HJ
-	13453-10431	Clutch cover 离合器压盘及盖总成	1	CPC20-35-HJ
16	B6150-00050	Snap ring 轴用弹性挡圈50	1	GB894.1-86
17	H24C3-12501	Retainer, spring 压簧	1	
18	Z2500-01010	Titting, grease 直通式压注油杯M10×1	2	GB1152-89
19	15533-10301	Bearing, thrust 分离轴承	1	
20	H24C3-12201	Yoke, clutch 操纵叉	1	
21	H24C3-12101	Retainer, bearing 分离轴承套筒	1	
22	12003-12021	Bushing 衬套	2	
23	B5310-00025	Washer 大垫圈25	1	GB97.1-85
24	B6150-00025	Snap ring 轴用弹性挡圈25	2	GB894.1-86

CPQ20,25,30-R6
CPQ,20H,25H-R11
CPQ30-R12
CPQ35-R3,R4
CPC20,25,30-W7,W8,W9,Xs1,HJ
CPC35-W4,W5,W6,Xs1,HJ

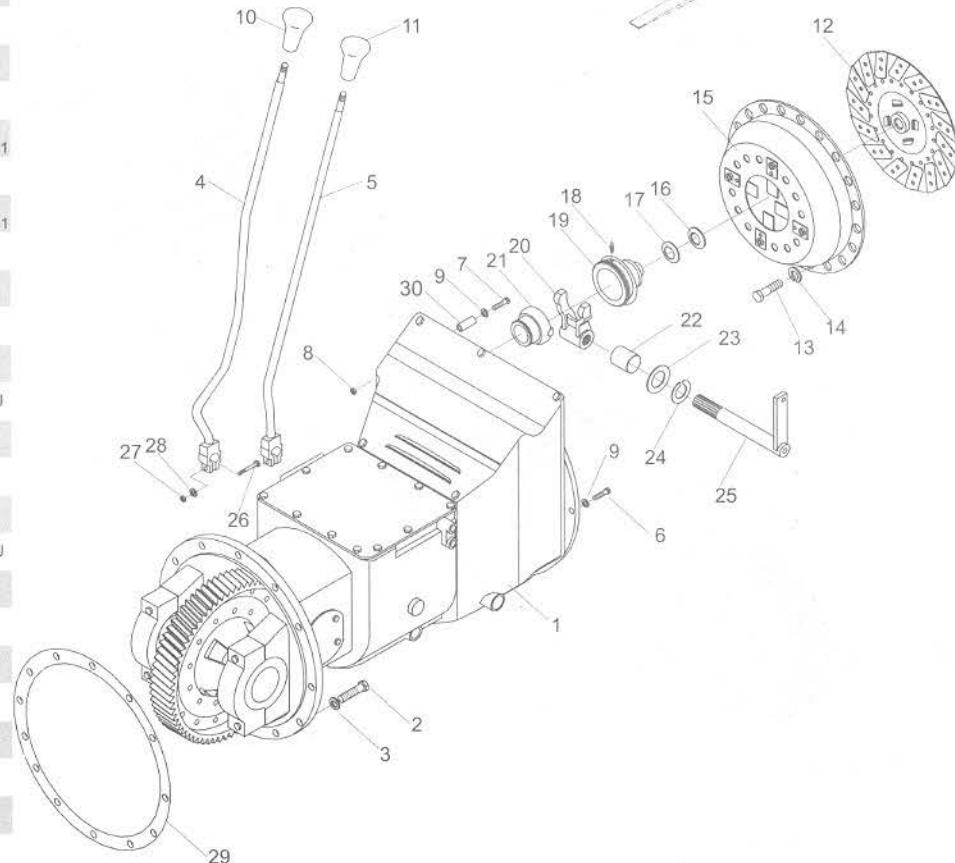
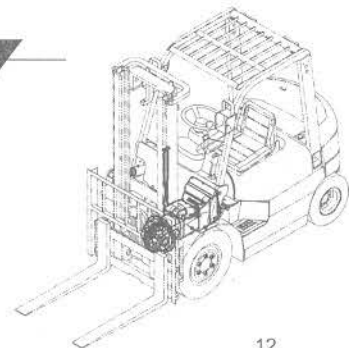

CPQ20,25,30-R6
 CPQ,20H,25H-R11
 CPQ30-R12
 CPQ35-R3,R4
 CPC20,25,30-W7,W8,W9,Xs1,HJ
 CPC35-W4,W5,W6,Xs1,HJ

序号 Item No	图号 Part No	零部件名称 Description	件数 Q'ty	备注 Remark
25	H24C3-10301	Link	1	连杆
26	B0212-08035	Bolt	2	螺栓M8 × 35-6g
27	B4115-00008	Nut	2	螺母M8
28	B5052-00008	Washer	2	垫圈8
29	24452-52001	Gasket	1	垫片
30	H21U3-42001	Gasket	1	垫 CPC20~35-Xs1



图69/FIG 69

传动装置安装(机械式)/DRIVE UNIT MOUNT (CLUTCH TYPE)

C12

序号 Item No	图号 Part No	零部件名称 Description	件数 Q'ty	备注 Remark
01	H24C3-40201	Drive unit 机械变速箱总成	1	
02	B0422-12040	Bolt 螺栓M12X1.25X40	12	GB5785-86
03	B5052-00012	Washer, lock 垫圈12	12	GB93-87
04	A23A2-50501	Lever, speed change 手柄杆	1	
05	A23A2-50301	Lever, direction change 手柄杆	1	
06	B0530-10035	Bolt 螺栓M10X1.25X35	6	GB5785-86
07	B0222-10050	Bolt 螺栓M10X50	1	GB5782-86
08	B4125-00010	Nut 螺母M10	1	GB6170-86
09	B5052-00010	Washer, lock 垫圈10	9	GB93-87
10	A22A2-52022	Knob, dirction 变速手柄头	1	
11	A22A2-52002	Knob, speed 换向手柄头	1	
12	129F3-12041	Clutch disc Ass'y 离合器摩擦片总成	1	
13	B0010-08020	Bolt 螺栓M8X20	6	GB5780-86
14	B5050-00008	Washer, lock 垫圈8	8	GB93-87
15	13553-10301A	Clutch cover 离合器压盘及盖总成	1	
16	B6150-00050	Snap ring 轴用弹性挡圈50	1	GB894.1-86
17	H24C3-12501	Retainer, spring 压簧	1	
18	Z2500-01010	Titting, grease 直通式压注油杯M10×1	2	GB1152-89
19	15533-10301	Bearing, thrust 分离轴承	1	
20	H24C3-12201	Yoke, clutch 操纵叉	1	
21	H24C3-12101	Retainer, bearing 分离轴承套筒	1	
22	12003-12021	Bushing 衬套	2	
23	B5310-00025	Washer 大垫圈25	1	GB97.1-85
24	B6150-00025	Snap ring 轴用弹性挡圈25	2	GB894.1-86
25	H24C3-10301	Link 连杆	1	
26	B0212-08035	Bolt 螺栓M8×35-6g	2	GB5782-86
27	B4115-00008	Nut 螺母M8	2	GB6170-86
28	H24C3-43001	Gasket, rubber 橡胶垫	1	
29	24452-52001	Gasket 垫片	1	
30	B0530-10030	Bolt 螺栓M10x1.25x30	2	GB5786-86

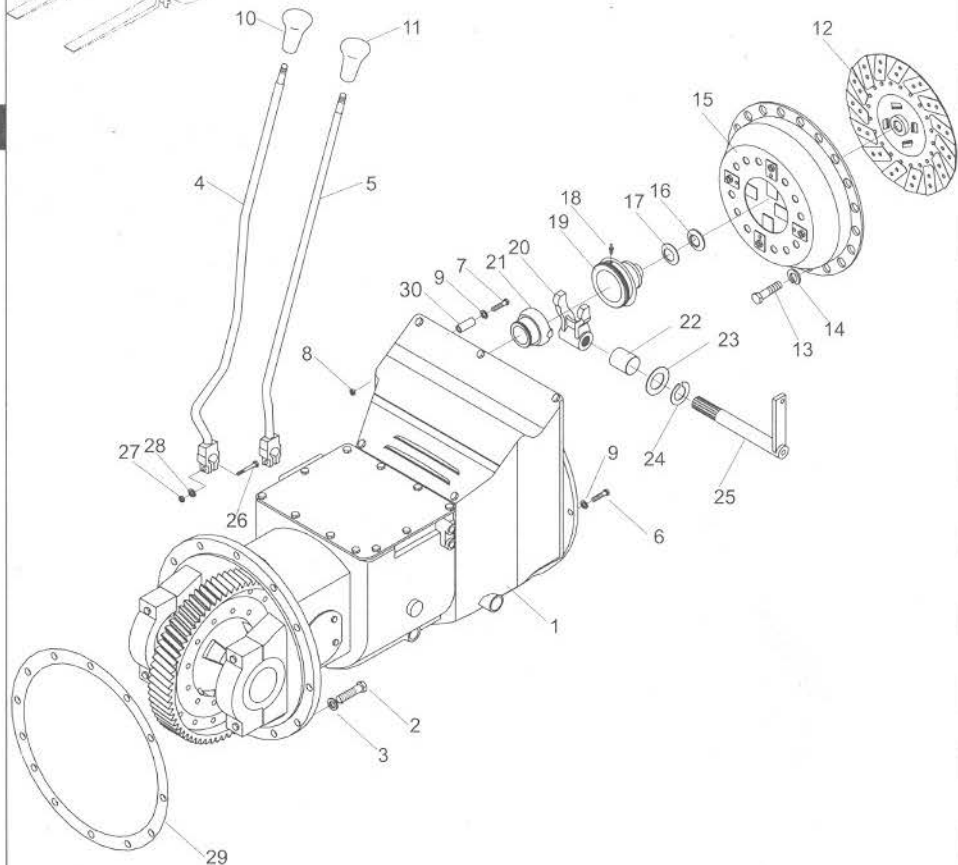
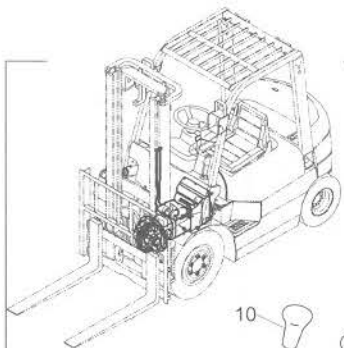
CPC20,25,30-Ku1

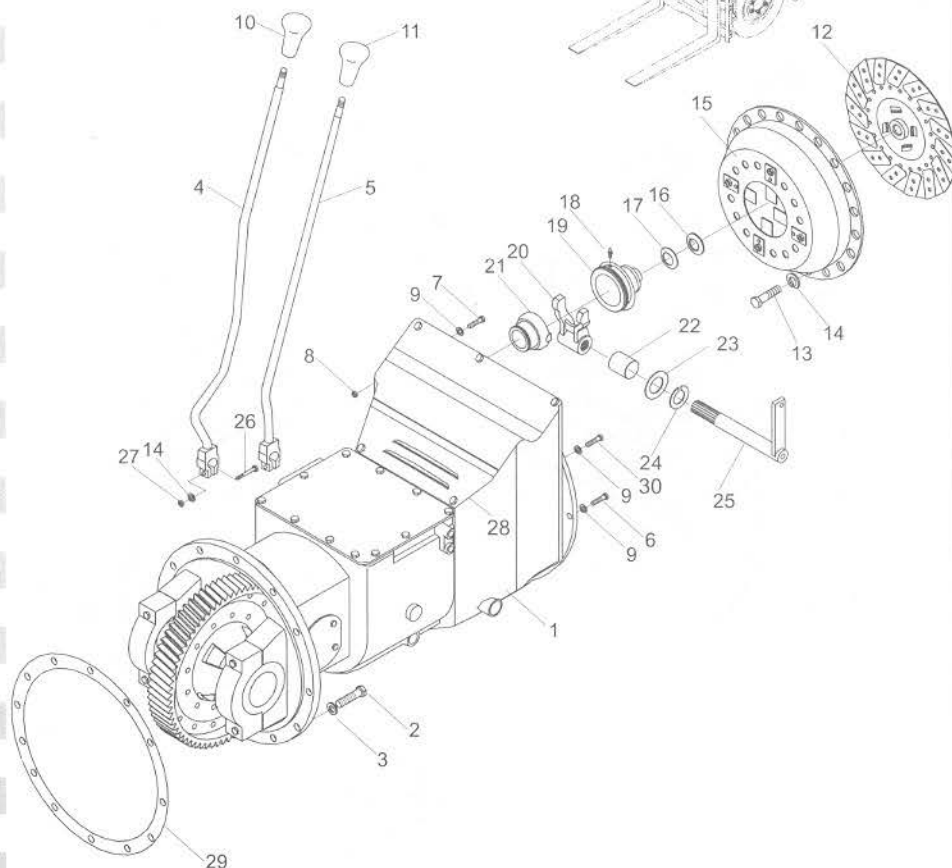

CPC20,25,30-Ku1

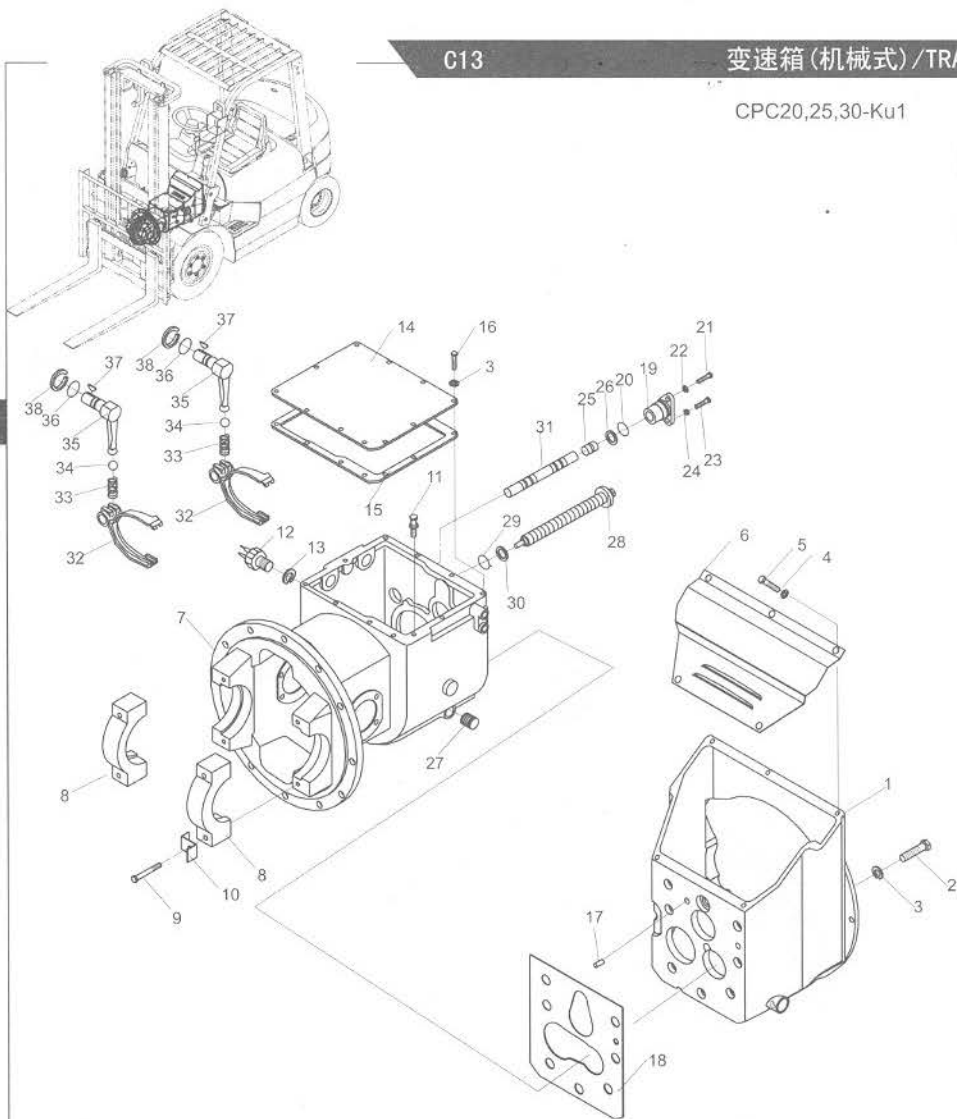

序号 Item No	图号 Part No	零部件名称 Description	件数 Q'ty	备注 Remark
01	H2A93-42011	Diver,unit sub	离合器壳	1
02	B0222-10030	Bolt	螺栓M10X30	7 GB5782-86
03	B5050-00010	Washer, lock	垫圈10	24 GB93-87
04	B5050-00006	Washer, lock	垫圈6	5 GB93-87
05	B0330-06012	Bolt	螺栓M6X12	5 GB5783-86
06	H24C3-42421	Cover, case	离合器盖	1
07	H24C3-42401	Case, transmission	机械变速箱壳	1
08	14453-22031	Cap, bearing	轴承座	2
09	15413-22021	Bolt	螺栓	4
10	14453-52111	Plate, lock	锁片	4
11	90106-65690	Air Breather	通气塞总成	1
12	12003-42451	Switch, back-lamp	倒车灯开关	1
13	12003-42461	Washer	垫片	1
14	12003-42021	Case, cover	箱盖	1
15	12003-42031	Gasket,case cover	箱盖垫片	1
16	B0320-10016	Bolt	螺栓M10X16	10 GB5783-86
17	B3120-12022	Pin	销12X22	2 GB119-86
18	12003-42042	Gasket, clutch housing	垫片	1
19	12003-42052	Supporter, arm shaft	轴臂	1
20	Z6004-03503	O-ring	O形圈35X3.1	1 GB1235-76
21	B0320-08020	Bolt	螺栓M8X20	1 GB5783-86
22	B5050-00008	Washer,lock	垫圈8	1 GB93-87
23	B0320-10045	Bolt	螺栓M10X45	1 GB5783-86
24	B4123-00010	Nut	螺母M10	1 GB6170-86
25	12003-42061	Plug	塞	1
26	Z6004-02004	O-ring	O形圈20X2.4	1 GB1235-76
27	G0121-00031	Plug	螺塞ZG1/2"	1
28	11153-40041	Bolt, slide	滑动螺栓	1
29	Z6004-02804	O-ring	O形圈28X3.5	1 GB1235-76
30	10113-40541	Washer	外齿弹性垫圈	1

图70/FIG70.

变速箱(机械式)/TRANSMISSION (CLUTCH TYPE) (1/2)

C13

序号 Item No	图号 Part No	零部件名称 Description	件数 Q'ty	备注 Remark
31	15573-42102	Rod, shift	换挡杆	1
32	12493-42112	Fork, shift	换挡拨叉	2
33	12003-42421	Spring	弹簧	2
34	Z1500-G1032	Ball, steel	钢球10	2 GB308-77
35	12003-42521	Lever, shift	转动杆	2
36	Z6003-02202	O-ring	O形圈22X2.4	2 GB1235-76
37	Z4000-05019	Key, woodruf	半圆键5X19	2 GB1099-79
38	B6150-00022	Snap ring	挡圈22	2 GB894.1-86

CPC20,25,30-Ku1

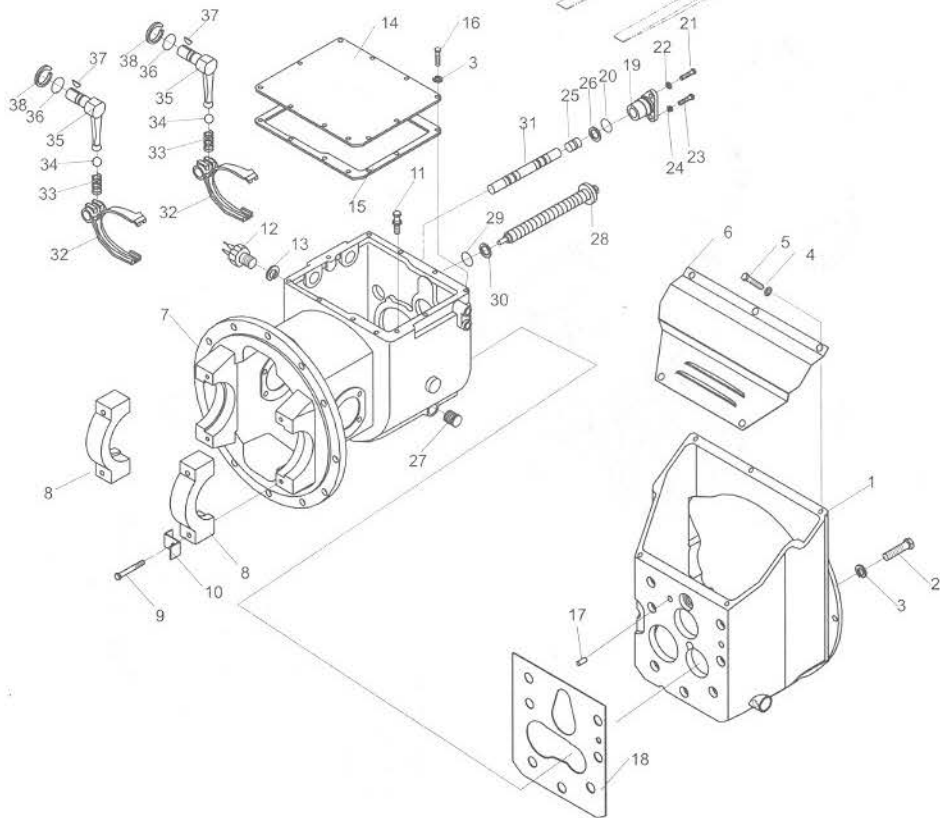

CPQ20,25,30-R6
 CPQ,20H,25H-R11
 CPQ30-R12
 CPQ35-R3,R4
 CPC20,25,30-W7,W8,W9,Xs1,HJ
 CPC35-W4,W5,W6,Xs1,HJ

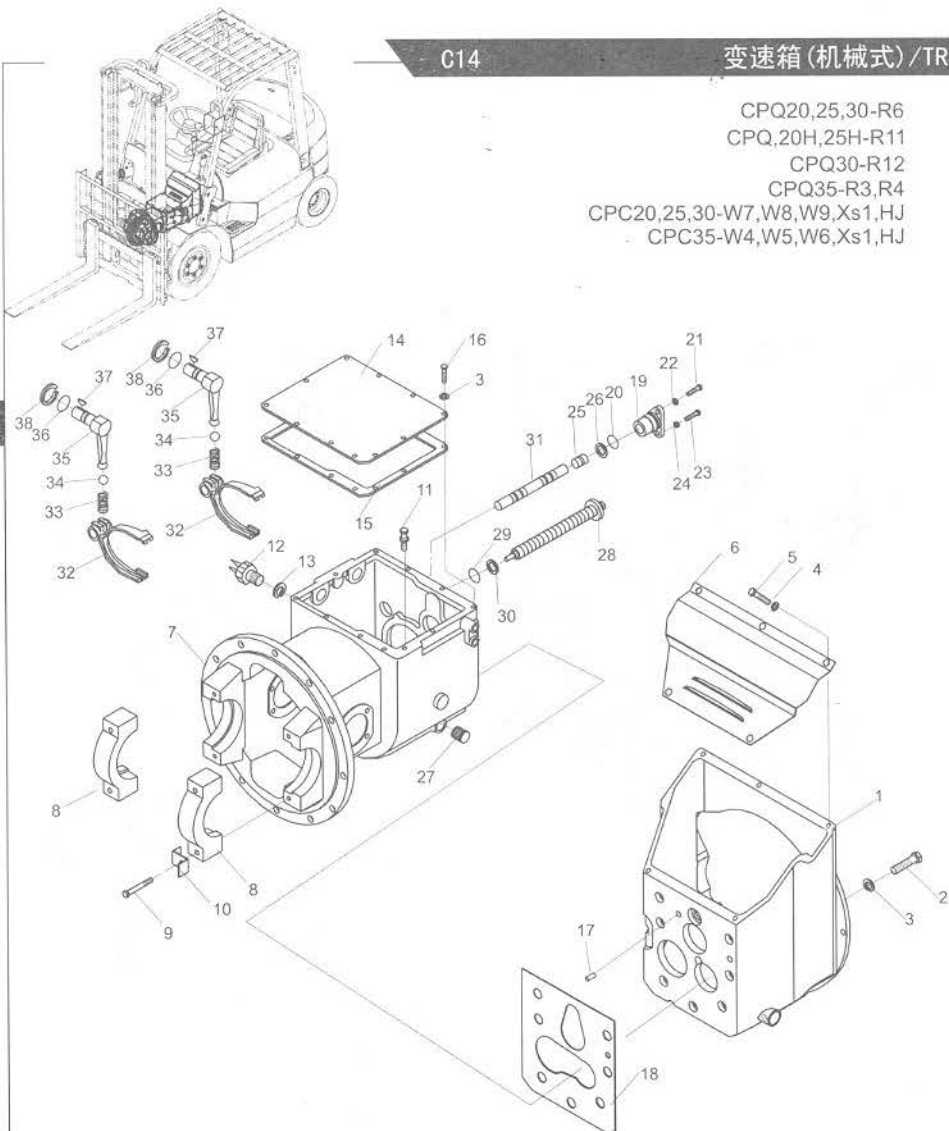

序号 Item No	图号 Part No	零部件名称 Description	件数 Q'ty	备注 Remark
01	H24C3-42201	Diver,unit sub	离合器壳	1
02	B0222-10030	Bolt	螺栓M10X30	7 GB5782-86
03	B5050-00010	Washer, lock	垫圈10	24 GB93-87
04	B5050-00006	Washer, lock	垫圈6	5 GB93-87
05	B0230-06010	Bolt	螺栓M6X10	5 GB5782-86
06	H24C3-42421	Cover, case	离合器盖	1
07	H24C3-42401	Case, transmission	机械变速箱壳	1
08	14453-22031	Cap, bearing	轴承座	2
09	15413-22021	Bolt	螺栓	4
10	14453-52111	Plate, lock	锁片	4
11	90106-65690	Air Breather	通气塞总成	1
12	12003-42451	Switch, back-lamp	倒车灯开关	1
13	12003-42461	Washer	垫片	1
14	12003-42021	Case, cover	箱盖	1
15	12003-42031	Gasket,case cover	箱盖垫片	1
16	B0320-10016	Bolt	螺栓M10X16	10 GB5783-86
17	B3120-12020	Pin	销12X20	2 GB119-86
-	B3130-12022	Pin	销12X22	2 除CPC20-35-Xs1外 GB119-86 CPC20-35-Xs1
18	12003-42042	Gasket, clutch housing	垫片	1
19	12003-42052	Supporter, arm shaft	轴臂	1
20	Z6004-03503	O-ring	O形圈35X3.1	1 GB1235-76
21	B0320-08020	Bolt	螺栓M8X20	1 GB5783-86
22	B5050-00008	Washer,lock	垫圈8	1 GB93-87
23	B0320-10045	Bolt	螺栓M10X45	1 GB5783-86
24	B4123-00010	Nut	螺母M10	1 GB6170-86
25	12003-42061	Plug	塞	1
26	Z6004-02004	O-ring	O形圈20X2.4	1 GB1235-76
27	G0121-00031	Plug	螺塞ZG1/2"	1
28	11153-40041	Bolt, slide	滑动螺栓	1
29	Z6004-02804	O-ring	O形圈28X3.5	1 GB1235-76

图71/FIG71

变速箱(机械式)/TRANSMISSION (CLUTCH TYPE) (1/2)

C14

序号 Item No	图号 Part No	零部件名称 Description	件数 Q'ty	备注 Remark
30	10113-40541	Washer 外齿弹性垫圈	1	
31	15573-42102	Rod, shift 换挡杆	1	
32	12493-42112	Fork, shift 换挡拨叉	2	
33	12003-42421	Spring 弹簧	2	
34	Z1500-G1032	Ball, steel 钢球10	2	GB308-89
35	12003-42521	Lever, shift 转动杆	2	
36	Z6003-02202	O-ring O形圈22X2.4	2	GB1235-76
37	Z4000-05019	Key, woodruf 半圆键5X19	2	GB1099-79
38	B6150-00022	Snap ring 挡圈22	2	GB894.1-86

CPQ20,25,30-R6
 CPQ,20H,25H-R11
 CPQ30-R12
 CPQ35-R3,R4
 CPC20,25,30-W7,W8,W9,Xs1,HJ
 CPC35-W4,W5,W6,Xs1,HJ

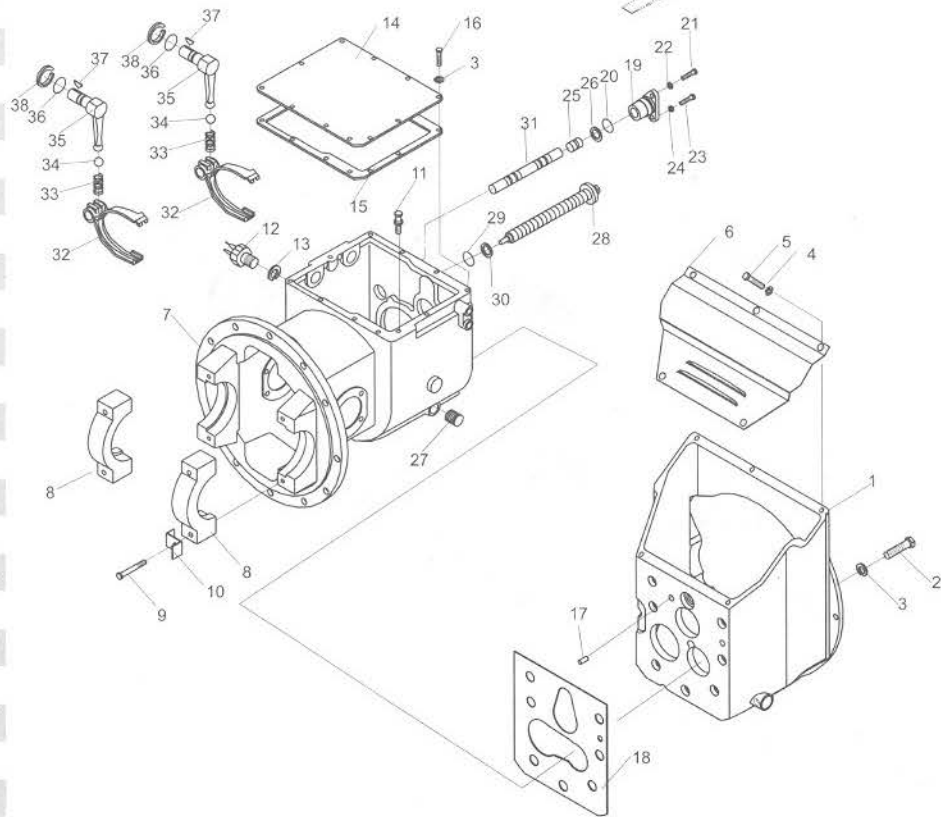
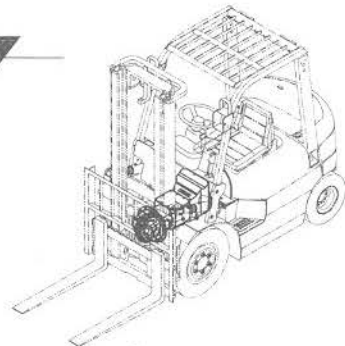

CPQ20,25,30-R6
CPQ,20H,25H-R11
CPQ30-R12
CPQ35-R3,R4
CPC20,25,30-W7,W8,W9,Xs1,HJ,Ku1
CPC35-W4,W5,W6,Xs1,HJ

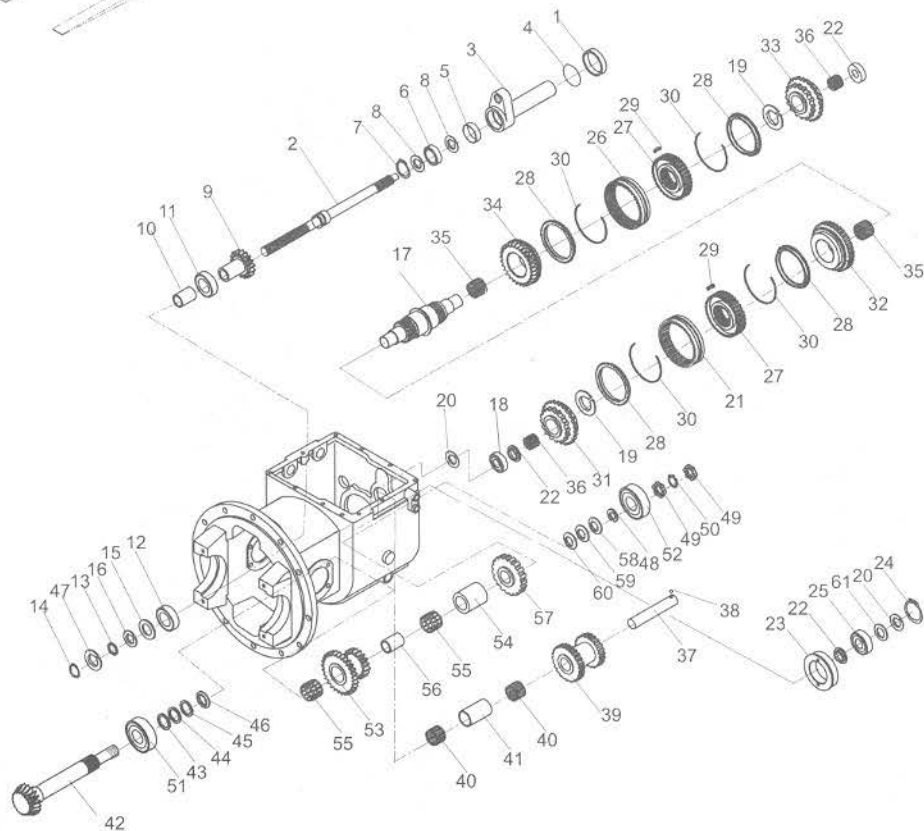
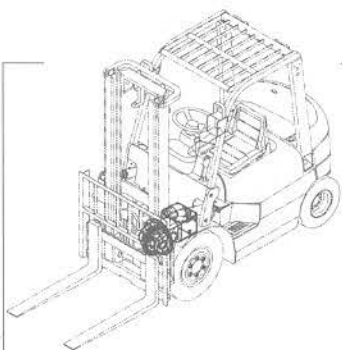

序号 Item No	图号 Part No	零部件名称 Description	件数 Q'ty	备注 Remark	
01	12003-42471	Collar	轴环	1	
02	H24C3-42001	Shaft, main drive	主动轴	1	
03	H24C3-42101	Retainer, bearing	轴承架	1	
04	Z6004-04204	O-ring	O形圈42×3.5	1	GB1235-76
05	03211-02501	Seal, oil	油封	1	
06	Z-105	Bearing, ball	单列向心球轴承105	1	GB276-93
07	B6050-00047	Snap ring	孔用挡圈47	1	GB893.2-86
08	B6150-00025	Snap ring	轴用挡圈25	2	GB894.1-86
09	12003-42111	Gear, input	输入齿轮	1	
10	10113-40161	Spacer	隔套	1	
11	Z-207	Bearing, ball	单列向心球轴承207	1	GB276-93
12	Z-50207	Bearing, ball	向心球轴承50207	1	GB272-93
13	10113-40521	Spacer	隔圈	1	
14	B6150-00035	Snap ring	轴用挡圈35	1	GB894.1-86
15	03006-06207	Ring, thrust	止动环72/78.6	1	9243/35
16	10113-40171	Spacer	轴承垫圈	1	
17	12493-42091	Shaft, main	主轴	1	
18	Z-42306	Bearing, ball	单列向心球轴承42306	1	GB276-93
19	N-1J01235-00Z	Snap ring	轴用弹性挡圈	2	
20	B6150-00030	Snap ring	轴用挡圈30	2	GB894.1-86
21	N-1J01272-01A	Gear sleeve	一、二同步器齿套	1	
22	12493-42131	Plate, thrust	止推摩擦片	2	
23	12493-42142	Retainer, bearing	轴承保持架	1	
24	B6050-00072	Snap ring	孔用挡圈72	1	GB893.2-86
25	Z-306	Bearing, ball	单列向心球轴承306	1	GB276-93
26	12493-42041	Gear sleeve	同步器齿套	1	
27	N-1J01271-01A	Gear hub	同步器齿毂	2	
28	N-1J01276-00A	Ring	一、二同步器齿环1/2	4	
29	D120-1J01092	Insert	同步器滑块	6	
30	N-1J01273-00A	Spring	弹簧	4	

图72/FIG72

变速箱(机械式)/TRANSMISSION (CLUTCH TYPE) (2/2)

C15

序号 Item No	图号 Part No	零部件名称 Description	件数 Q'ty	备注 Remark
31	12493-42081	Gear, high speed	1	高速齿轮
32	12493-42071	Gear, low speed	2	低速齿轮
33	12493-42051	Gear, forward	1	前进档齿轮
34	12493-42061	Gear, reverse	1	倒档齿轮
35	N-1J01260-02A	Bearing, needle	2	滚针轴承
36	12003-42251	Bearing, needle 无套圈有保持架滚针轴承	2	
37	12003-42261	Shaft, reverse idler	1	惰轮轴
38	Z1505-00100	Ball, steel	1	钢球1/4"
39	12003-42271	Gear, reverse idler	1	惰轮
40	12003-42281	Bearing, needle	2	滚针轴承
41	12003-42291	Spacer	1	衬套
42	14453-42001	Shaft, output	1	输出轴
43	12003-42311	Shim	1	垫片
44	12003-42321	Shim	2	垫片
45	12003-42331	Shim	2	垫片
46	12003-42341	Plate, thrust	1	止推垫圈
47	B6050-00080	Snap ring	1	孔用挡圈80
48	20113-40251	Washer, spring	1	弹簧垫圈
49	03192-00005	Nut	2	圆螺母M25×1.5
50	B5512-00025	Washer, thrust	1	圆螺母止动垫圈25
51	Z-7508	Bearing, taper roller	1	圆锥滚子轴承7508
52	Z-7605	Bearing, taper roller	1	圆锥滚子轴承7605
53	12003-42372	Gear, cluster	1	双连齿轮
54	12003-42531	Spacer	1	衬套
55	12003-42091	Bearing, needle	2	滚针轴承
56	12003-42381	Spacer	1	衬套
57	12003-42391	Gear, output	1	输出齿轮
58	12003-42361	Plate, thrust	1	止推板 按需
59	12003-42541	Plate, thrust	1	止推板 按需
60	12003-42551	Plate, thrust	1	止推板 按需
61	12003-42481	Spacer	1	隔圈

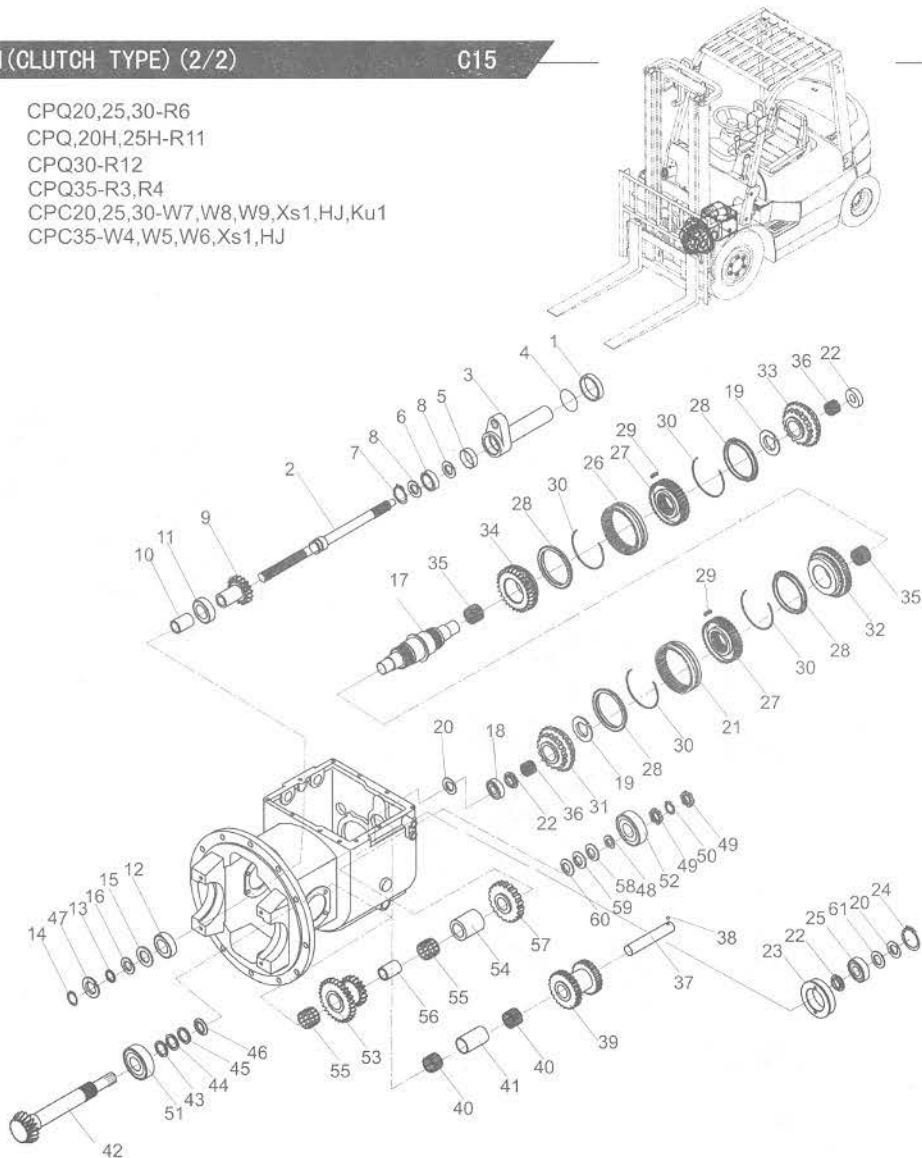

CPC20,25,30-X6,D
CPC35-X2,D
CPQ20,25,30,35-ZJ2,ZJ3

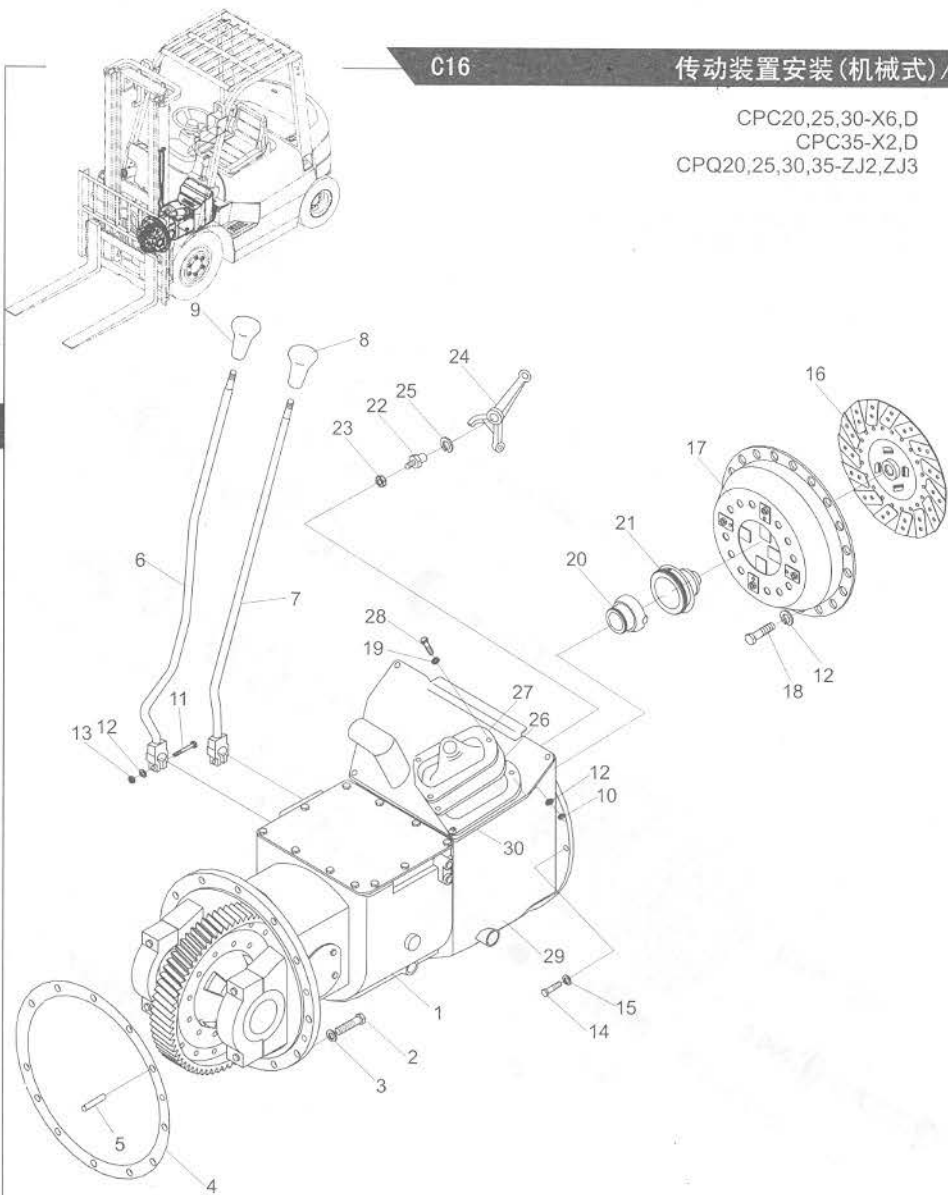

序号 Item No	图号 Part No	零部件名称 Description	件数 Q'ty	备注 Remark
01	14432-51000G	Drive unit 机械变速箱总成	1	
02	B0530-12040	Bolt 螺栓 M12X1.25X40	12	GB5786-86
03	B5050-00012	Washer, lock 垫圈12	12	GB93-87
04	24452-52001	Gasket 垫片	1	
05	B3120-08030	Pin, parallel 销B8X30	1	GB119-86
06	A22A2-50501	Lever, speed change 变速杆	1	
07	A22A2-50301	Lever, direction change 换向杆	1	
08	A22A2-52001	Knob, dirction 换向手柄	1	
09	A22A2-52021	Knob, speed 变速手柄	1	
10	B4610-00008	Nut 螺母M8	2	GB41-86
11	B0230-08035	Bolt 螺栓M8X35	2	GB5782-86
12	B5050-00008	Washer, lock 垫圈8	10	GB93-87
13	B4116-00008	Nut 螺母M8	2	GB6170-86
14	B0330-10035	Bolt 螺栓M10X35	9	GB5783-86
15	B5050-00010	Washer, lock 垫圈10	9	GB93-87
16	13453-10301	Clutch disc Ass'y 离合器摩擦片总成	1	2t,2.5t
-	13453-10331	Clutch disc Ass'y 离合器摩擦片总成	1	3t,3.5t
17	13453-10402G	Clutch cover 离合器压盘及盖总成	1	2t,2.5t
-	13453-10431	Clutch cover 离合器压盘及盖总成	1	3t,3.5t
18	B0320-08020	Bolt 螺栓M8X20	6	GB5783-86
19	B5310-00008	Washer 垫圈8	2	GB97.1-85
20	15533-12031G	Retainer, bearing 分离轴承套筒	1	2t,2.5t
-	15533-12041	Retainer, bearing 分离轴承套筒	1	3t,3.5t
21	Z-9688211	Bearing, thrust 分离轴承9688211	1	
22	13073-12001	Pivot, clutch yoke 支撑螺栓	1	
23	B4216-00012	Nut 螺母M12X1.25	1	GB6171-86
24	10113-10122	Yoke, clutch 分离叉	1	
25	10113-10081	Snap ring 弹簧挡圈	1	
26	13453-12052	Cover dust 分离叉护罩	1	
27	13453-12062	Retainer, cover 压板	1	

图73/FIG73

传动装置安装(机械式)/DRIVE UNIT MOUNT (CLUTCH TYPE)

C16

序号 Item No	图号 Part No	零部件名称 Description	件数 Q'ty	备注 Remark
28	B0330-08016	Bolt	2	GB5783-86
29	H94N2-52001	Clutch housing	1	CPQ20,25,30,35- ZJ2,ZJ3
-	10063-11070G	Clutch housing	1	CPC20,25,30-X6,S2
30	20062-59001	Gasket, rubber	1	橡胶垫

CPC20,25,30-X6,D
CPC35-X2,D
CPQ20,25,30,35-ZJ2,ZJ3

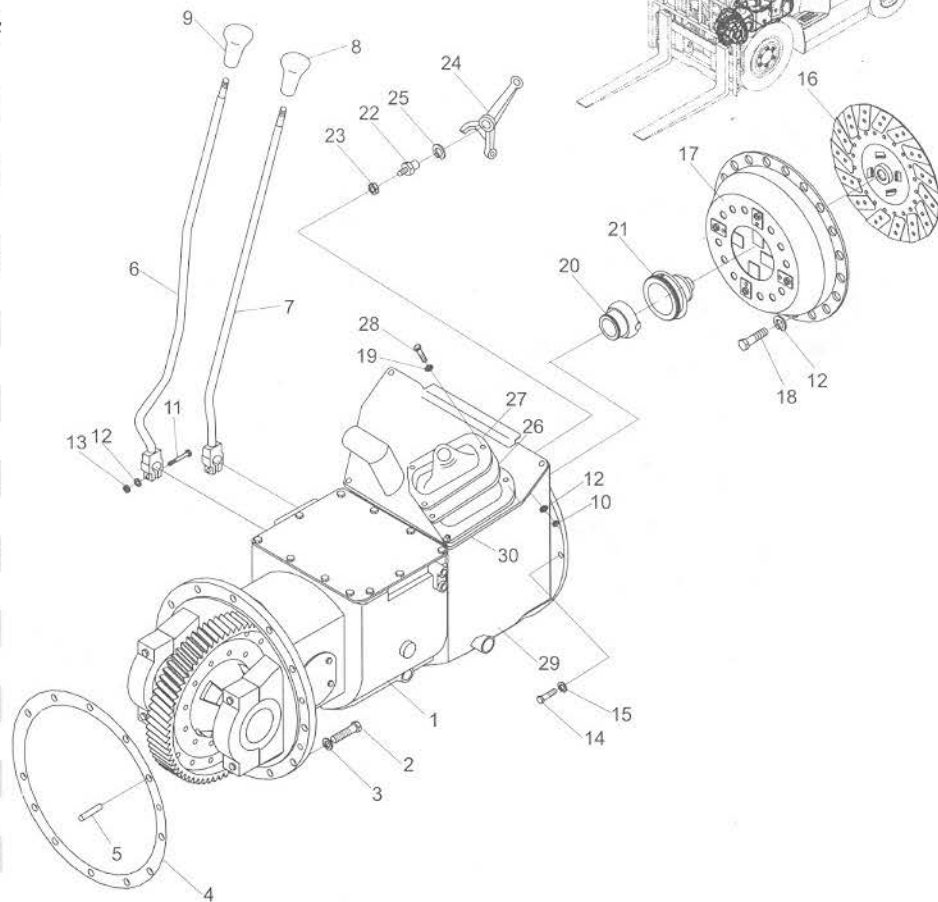

CPC20,25,30-X6,D
CPC35-X2,D
CPQ20,25,30,35-ZJ2,ZJ3

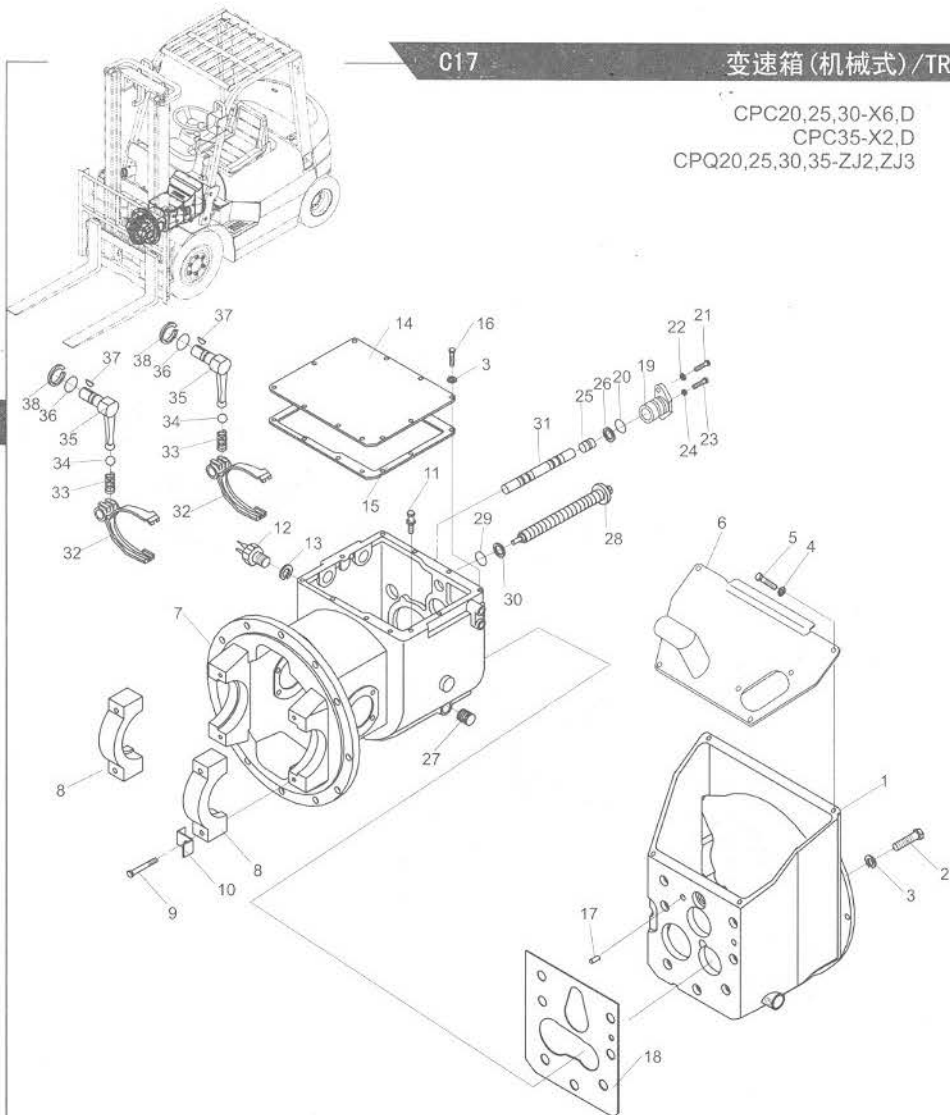

序号 Item No	图号 Part No	零部件名称 Description	件数 Q'ty	备注 Remark
01	10063-11070G	Diver,unit sub	离合器壳	1
02	B0330-10030	Bolt	螺栓M10X30	7 GB5783-86
03	B5050-00010	Washer, lock	垫圈10	24 GB93-87
04	B5050-00006	Washer, lock	垫圈6	4 GB93-87
05	B0330-06016	Bolt	螺栓M6X16	4 GB5783-86
06	H93C3-40201	Cover, case	离合器盖	1
07	HRA4753401 14753-42010	Case, transmission	机械变速箱壳	1
08	14453-22031	Cap, bearing	轴承座	2
09	15413-22021	Bolt	螺栓	4
10	14453-52111	Plate, lock	锁片	4
11	90106-65690	Air Breather	通气塞总成	1
12	12003-42451	Switch, back-lamp	倒车灯开关	1
13	12003-42461	Washer	垫片	1
14	12003-42021	Case, cover	箱盖	1
15	12003-42031	Gasket,case cover	箱盖垫片	1
16	B0320-10016	Bolt	螺栓M10X16	10 GB5783-86
17	B3120-12020	Pin	销B12X20	2 GB119-86
18	12003-42042	Gasket, clutch housing	垫片	1
19	12003-42052	Supporter, arm shaft	轴臂	1
20	Z6004-03503	O-ring	O形圈35X3	1 GB1235-76
21	B0320-08020	Bolt	螺栓M8X20	1 GB5783-86
22	B5050-00008	Washer, lock	垫圈8	1 GB93-87
23	B0320-10045	Bolt	螺栓M10X45	1 GB5783-86
24	B4123-00010	Nut	螺母M10	1 GB6170-86
25	12003-42061	Plug	塞	1
26	Z6004-02004	O-ring	O形圈20X2	4 GB1235-76
27	G0121-00031	Plug	锥管螺纹内六角螺塞ZG1/2"	1 Q/ZB285.4-77
28	11153-40041	Bolt, slide	滑动螺栓	1
29	Z6004-02804	O-ring	O形圈28X3	5 GB1235-76
30	10113-40541	Washer	外齿弹性垫圈	1

图74/FIG74

变速箱(机械式)/TRANSMISSION (CLUTCH TYPE) (1/2)

C17

序号 Item No	图号 Part No	零部件名称 Description	件数 Qty	备注 Remark
31	15573-42102	Rod, shift	换挡杆	1
32	12493-42112	Fork, shift	换挡拨叉	2
33	12003-42421	Spring	弹簧	2
34	Z1500-G1032	Ball, steel	钢球 $\varnothing 10$	2 GB308-77
35	12003-42521	Lever, shift	转动杆	2
36	Z6003-02202	O-ring	O形圈22X2.4	2 GB1235-76
37	Z4000-05019	Key, half-round	半圆键5X19	2 GB1099-79
38	B6150-00022	Snap ring	弹性挡圈22	2 GB894.1-86

CPC20,25,30-X6,D
CPC35-X2,D
CPQ20,25,30,35-ZJ2,ZJ3

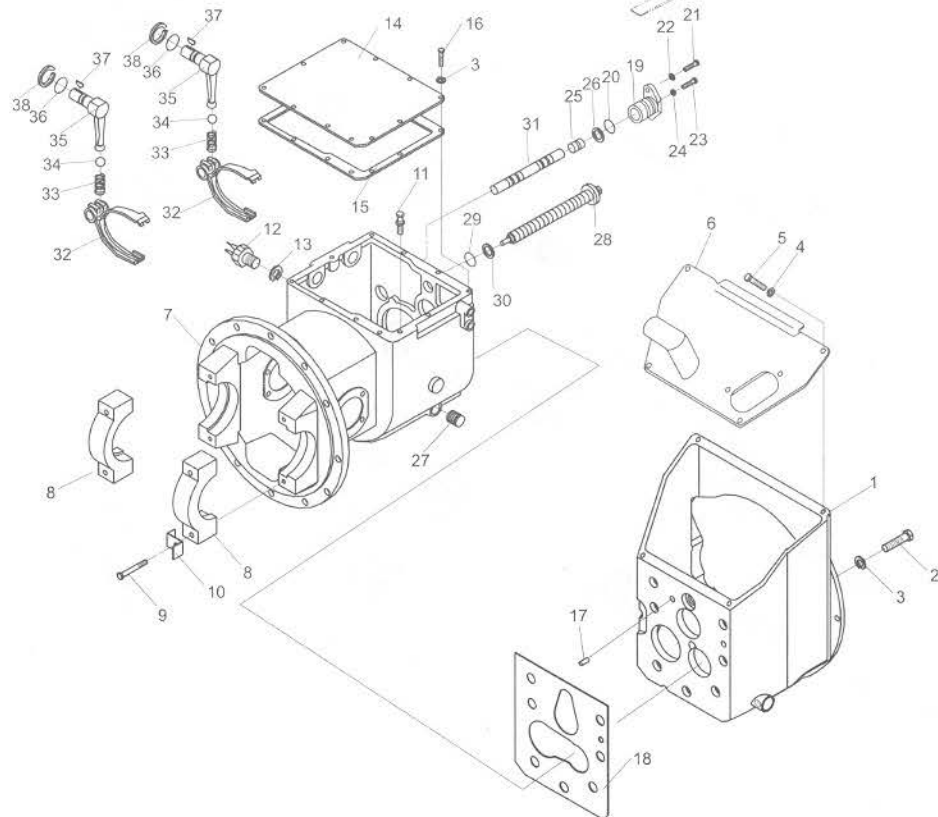

CPC20,25,30-X6,D
CPC35-X2,D
CPQ20,25,30,35-ZJ2,ZJ3

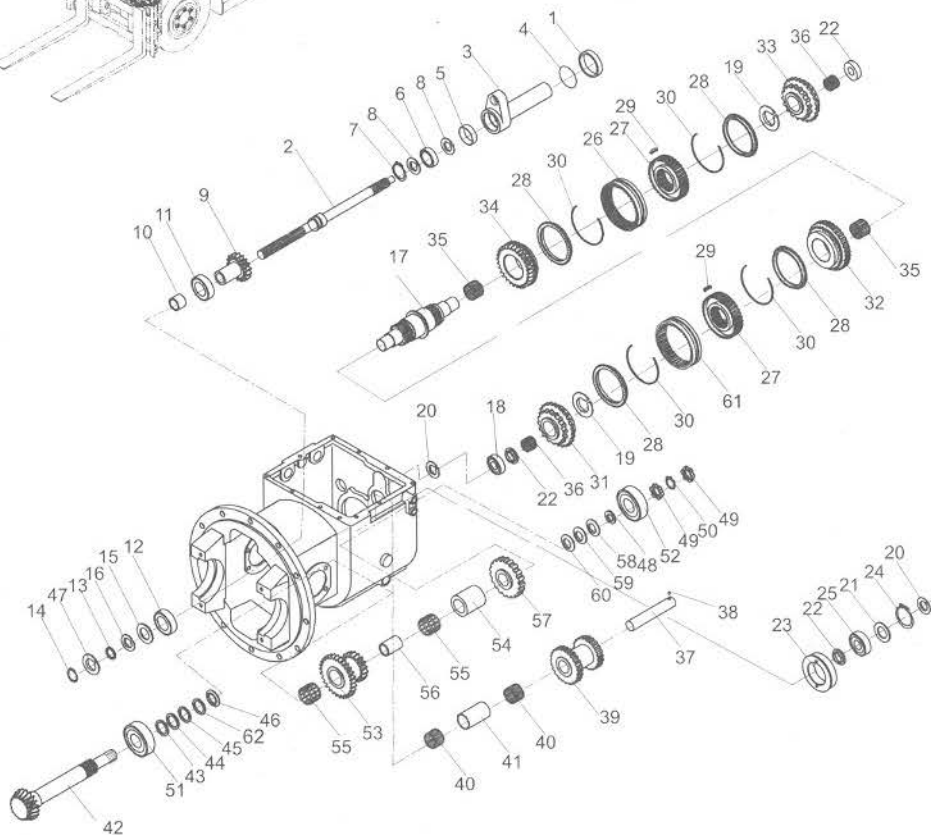
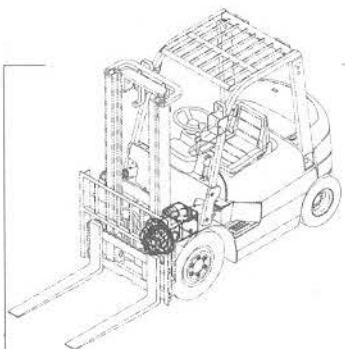

序号 Item No	图号 Part No	零部件名称 Description	件数 Q'ty	备注 Remark	
01	12003-42471	Collar	轴环	1	
02	12003-42081	Shaft, main drive	主动轴	1	
03	12003-42102	Retainer, bearing	轴承架	1	
04	Z6004-04204	O-ring	O形圈42×3.5	1	GB1235-76
05	03211-02501	Seal, oil	油封	1	
06	Z-105	Bearing, ball	单列向心球轴承105	1	GB276-93
07	B6050-00047	Snap ring	孔用挡圈47	1	GB893.2-86
08	B6150-00025	Snap ring	轴用挡圈25	2	GB894.1-86
09	12003-42111	Gear, input	输入齿轮	1	
10	10113-40161	Spacer	隔套	1	
11	Z-207	Bearing, ball	单列向心球轴承207	1	GB276-93
12	Z-50207	Bearing, ball	向心球轴承50207	1	GB272-93
13	10113-40521	Spacer	隔圈	1	
14	B6150-00035	Snap ring	挡圈35	1	GB894.1-86
15	03006-06207	Ring, thrust	止动环72/78.6	1	9243/35
16	10113-40171	Spacer	轴承垫圈	1	
17	12493-42091	Shaft, main	主轴	1	
18	Z-42306	Bearing, ball	单列向心球轴承42306	1	GB283-87
19	N-1J01235-00Z	Snap ring	弹簧挡圈	2	
20	B6150-00030	Snap ring	挡圈30	2	GB894.1-86
21	12003-42481	Spacer	隔圈	1	
22	12493-42131	Plate, thrust	止推摩擦片	2	
23	12493-42142	Retainer, bearing	轴承保持架	1	
24	B6050-00072	Snap ring	孔用挡圈72	1	GB893.2-86
25	Z-306	Bearing, ball	单列向心球轴承306	1	GB276-64
26	12493-42041	Gear sleeve	同步器齿套	2	
27	N-1J01271-01A	Gear hub	同步器齿毂	2	
28	N-1J01276-00A	Ring	一、二挡同步器齿环1/2	4	
29	D120-1J01092	Insert	同步器滑块	6	
30	N-1J01273-00A	Spring	同步器弹簧	4	

图75/FIG 75

变速箱(机械式)/TRANSMISSION (CLUTCH TYPE) (2/2)

C18

序号 Item No	图号 Part No	零部件名称 Description	件数 Q'ty	备注 Remark
31	12493-42081	Gear, high speed	高速齿轮	1
32	12493-42071	Gear, low speed	低速齿轮	1
33	12493-42051	Gear, forward	前进档齿轮	1
34	12493-42061	Gear, reverse	倒档齿轮	1
35	N-1J01260-02A	Bearing, needle	滚针轴承	2
36	12003-42251	Bearing, needle 无套圈有保持架滚针轴承	滚针轴承	2
37	12003-42261	Shaft, reverse idler	惰轮轴	1
38	Z1505-00100	Ball, steel	钢球1/4"	1 GB308-77
39	12003-42271	Gear, reverse idler	惰轮	1
40	12003-42281	Bearing, needle	滚针轴承	2
41	12003-42291	Spacer	衬套	1
42	14453-42001	Shaft, output	输出轴	1
43	12003-42311	Shim	垫片	1
44	12003-42321	Shim	垫片	2
45	12003-42331	Shim	垫片	2
46	12003-42341	Plate, thrust	止推垫圈	1
47	B6050-00080	Snap ring	孔用挡圈80	1 GB893.2-86
48	20113-40251	Washer, spring	弹簧垫圈	1
49	03192-00005	Nut	圆螺母M24×1.5	2 GB812-88
50	B5512-00025	Washer, thrust	圆螺母止动垫圈25	1 GB858-88
51	Z-7508	Bearing, taper roller	圆锥滚子轴承7508	1 GB297-64
52	Z-7605	Bearing, taper roller	圆锥滚子轴承7605	1 GB297-64
53	12003-42372	Gear, cluster	双连齿轮	1
54	12003-42531	Spacer	衬套	1
55	12003-42251	Bearing, needle	滚针轴承	2
56	12003-42381A	Spacer	衬套	1
57	12003-42391	Gear, output	输出齿轮	1
58	12003-42361	Plate, thrust	止推板	按需
59	12003-42541	Plate, thrust	止推板	按需
60	12003-42551	Plate, thrust	止推板	按需

CPC20,25,30-X6,D
CPC35-X2,D
CPQ20,25,30,35-ZJ2,ZJ3

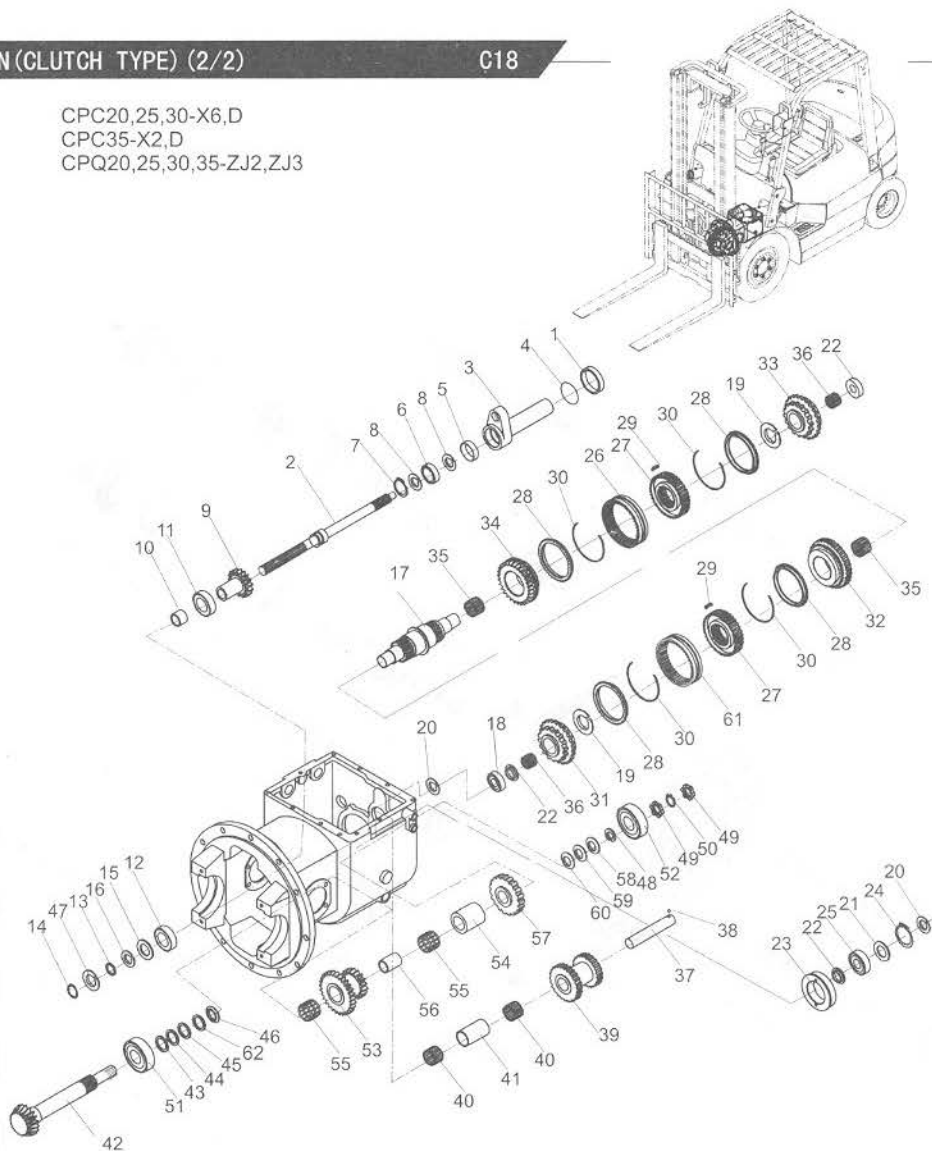

CPC20,25,30-X6,D
CPC35-X2,D
CPQ20,25,30,35-ZJ2,ZJ3

序号 Item No	图号 Part No	零部件名称 Description	件数 Qty	备注 Remark
61	N-1J01272-01A	Gear sleeve 一、二档同步器齿套1/2	1	
62	12003-42351	Shim 垫片	1	



图76/FIG76

驱动桥/DRIVE AXLE

C19

序号 Item No	图号 Part No	零部件名称 Description	件数 Q'ty	备注 Remark	
01	A22A3-02041	Housing, axle	桥壳	1	2t,2.5t
-	A22J3-02021	Housing, axle	桥壳	1	3t
-	A01A3-00202	Housing, axle	桥壳	1	3.5t
02	24453-02121G	Retainer, oil seal	油封挡圈	2	
03	Z6311-10014	Seal, oil	U型密封圈FB100X125X12D	2	
04	22493-00030G	Retainer	挡油圈	2	3t
05	22493-00020G	Washer	备用垫	2	
06	Z-30214	Bearing	轴承30214	2	GB/T297-94
07	B3120-10030	Pin	销B10×30	1	GB119-86
08	22673-02031	Drum, brake	制动鼓	2	2t,2.5t 单胎Single tire
-	22673-02031G2	Drum, brake	制动鼓	2	2t,2.5t 双胎Double tire
-	24453-02131	Drum, brake	制动鼓	2	3t,3.5t
09	A22A3-02011	Hub, front	轮毂	2	2t,2.5t 单胎Single tire
-	A22A3-02071	Hub, front	轮毂	2	2t,2.5t 双胎Double tire
-	24453-02031G	Hub, front	轮毂	2	3t,3.5t
10	23453-02071	Oil seal ass'y	轴承油封总成	2	
11	23453-02091	Packing	垫	2	
12	B4732-00060	Nut	螺母M60×2	4	GB810-88
13	B5512-00060	Washer	垫圈60	2	GB858-88
14	HRH24C3001 H24C3-02001	Shaft, drive	半轴	2	2t,2.5t
-	HRH24C3001 H24N3-02001	Shaft, drive	半轴	2	3t,3.5t
15	A22A3-02031	Packing	半轴垫	2	
16	24453-02061	Bolt	螺栓	24	
17	22253-02063b	Breather, air	透气塞	1	
18	22193-03001	Flug	堵塞	3	
19	A22A3-02051	Bolt	螺栓	12	
20	25953-72001	Bolt	螺栓	4	
21	B4223-00020	Nut	螺母M20×1.5	12	GB6171-86
22	REF206486 24353-72001	Bolt	螺栓柱	12	2t,2.5t 单胎Single tire
-	REF206486 25303-02102	Bolt	螺栓柱	12	3t,3.5t 单胎Single tire

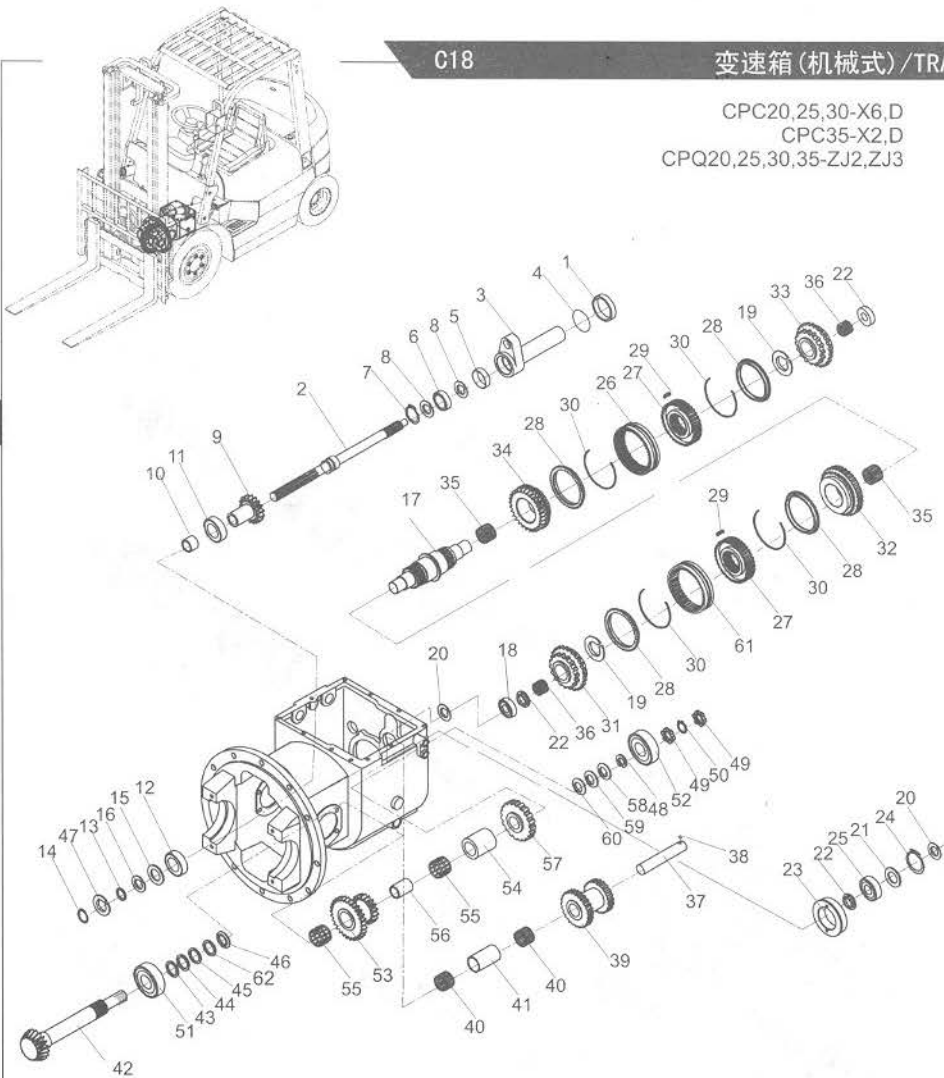
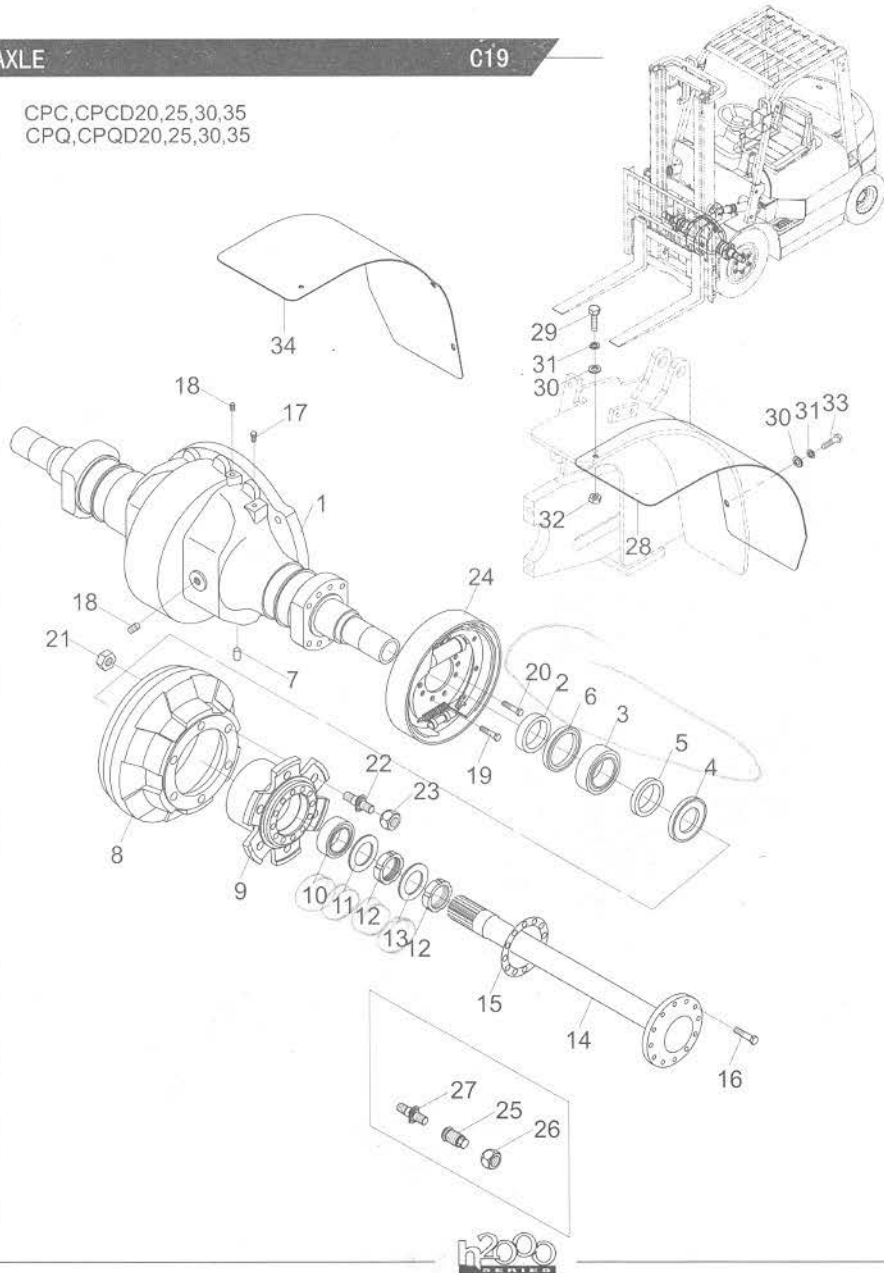
CPC, CPCD20, 25, 30, 35
CPQ, CPQD20, 25, 30, 35

CPC,CPD20,25,30,35
CPQ,CPQD20,25,30,35

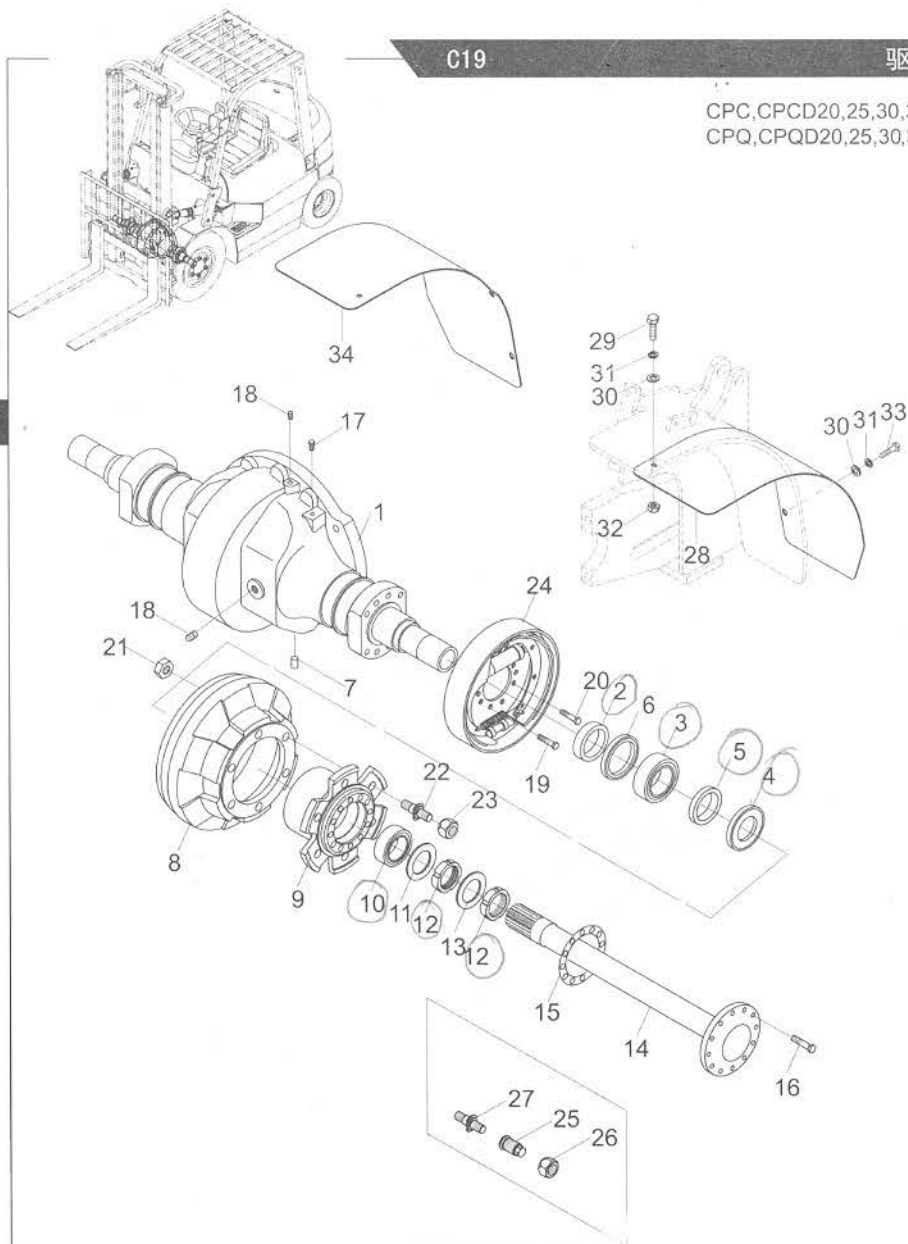

序号 Item No	图号 Part No	零部件名称 Description	件数 Q'ty	备注 Remark
23	24354-32311	Nut	12	2t,2.5t 单胎Single tire
-	23913-02041	Nut	12	3t,3.5t 单胎Single tire
24	REF000560	Wheel brake	2	2-2.5t see Fig.81
-	REF000567	Wheel brake	2	3t,3.5t see Fig.82
25	24463-00050G	Nut, hub	12	3t,3.5t 双胎Double tire
-	24463-00050G2	Nut, hub	12	2t,2.5t 双胎Double tire
26	24463-00060G	Nut, hub	12	3t,3.5t 双胎Double tire
-	24463-00060G2	Nut, hub	12	2t,2.5t 双胎Double tire
27	24463-00040G	Bolt, hub	12	3t,3.5t 双胎Double tire
-	24353-72001G2	Bolt, hub	12	2t,2.5t 双胎Double tire
28	HRH24C3006 H24C3-02061	Fender	1	2t,2.5t 双胎Double tire
-	HRH24C3006 H24C3-02081	Fender	1	3t,3.5t 双胎Double tire
29	B0320-10035	Bolt	4	双胎Double tire GB5783-86
30	B5210-00010	Washer	8	双胎Double tire GB96-85
31	B5050-00010	Washer,lock	8	双胎Double tire GB93-87
32	B4116-00010	Nut	4	双胎Double tire GB6170-86
33	B0420-10020	Bolt	4	双胎Double tire GB5785-86
34	HRH24C3006 H24C3-02071	Fender	1	2t,2.5t 双胎Double tire
-	HRH24C3006 H24C3-02091	Fender	1	3t,3.5t 双胎Double tire

图77/F1G77

驱动轮(单胎)/DRIVE WHEEL (2t, 2.5t, SINGLE TIRE)

C20

序号 Item No	图号 Part No	零部件名称 Description	件数 Q'ty	备注 Remark
A	HRA20A4401	Front wheel	车轮 2	
01	23454-42091G	Rim, outside	外轮辋 5.00S-12DT 2	
02	23454-42021G	Rim, inside	内轮辋 5.00S-12DT 2	
03	B4123-00016	Nut	螺母M16 12	GB6170-86
04	B5050-00016	Washer, lock	垫圈16 12	GB93-87
05	23454-42101G	Bolt	轮辋螺栓 12	
06	Z3004-70012	Tyre	轮胎7.00-12-12PR 2	GB/T 2982-2001
-	Z3200-70012	Solid tyre	实心胎7.00-12 2	GB10823-89

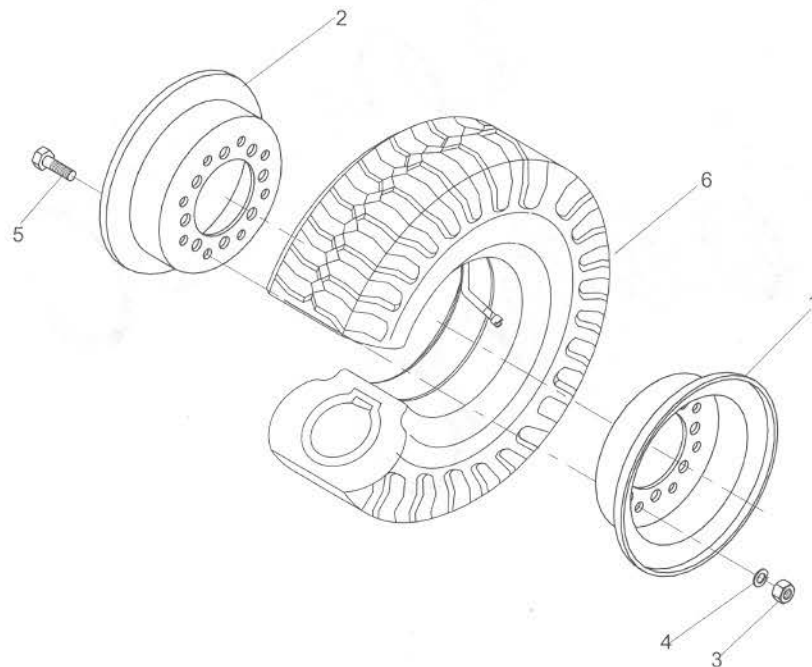
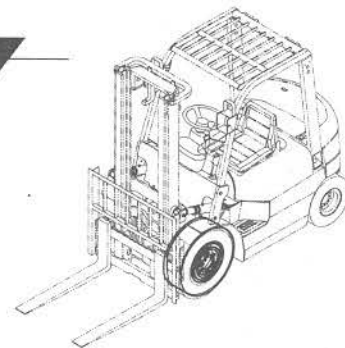
CPC, CPCD20, 25
CPQ, CPQD20, 25

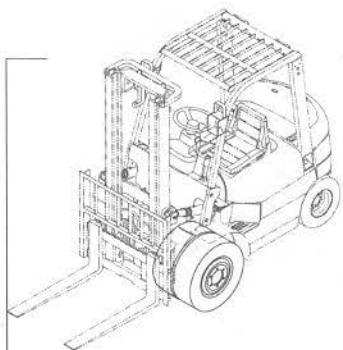

CPC, CPCD20, 25
CPQ, CPQD20, 25

序号 Item No	图号 Part No	零部件名称 Description	件数 Q'ty	备注 Remark
01	Z3004-70012	Tyre 轮胎7.00-12-12PR	4	GB/T2982-2001
-	Z3200-70012	Solid tyre 实心轮胎7.00-12	4	GB10823-89
A	22493-02001G	Wheel rim ass'y(Inc.2,4,5) 外轮辋总成	2	
B	22493-01000G2	Wheel rim ass'y(Inc.3,4,5) 内轮辋总成	2	
02	22493-02100G2	Wheel rim 外轮辋体	2	
03	22493-01100G2	Wheel rim 内轮辋体	2	
04	22493-01010G2	Lock ring 锁圈	4	
05	22493-01020G2	Snap ring 挡圈	4	
06	25783-02240	Pipe 充气接管	2	
07	24493-04000G	Bracket 支架	2	左右对称各一 Left & right types



图79/FIG79

驱动轮(单胎)/DRIVE WHEEL (3t, 3.5t SINGLE TIRE)

C22

序号 Item No	图号 Part No	零部件名称 Description	件数 Q'ty	备注 Remark
01	Z3014-90015	Tyre 轮胎28X9-15-12PR	2	GB/T2982-2001
-	Z3300-90015	Solid tyre 实心轮胎28X9-15	2	GB10823-89
A	24454-40222G	Wheel rim ass'y(Inc.2,3) 轮辋总成	2	
02	24439-44032G	Wheel rim 轮辋体总成(7.00T-15)	2	
03	24454-42002G	Snap ring 挡圈(7.00T-15)	2	

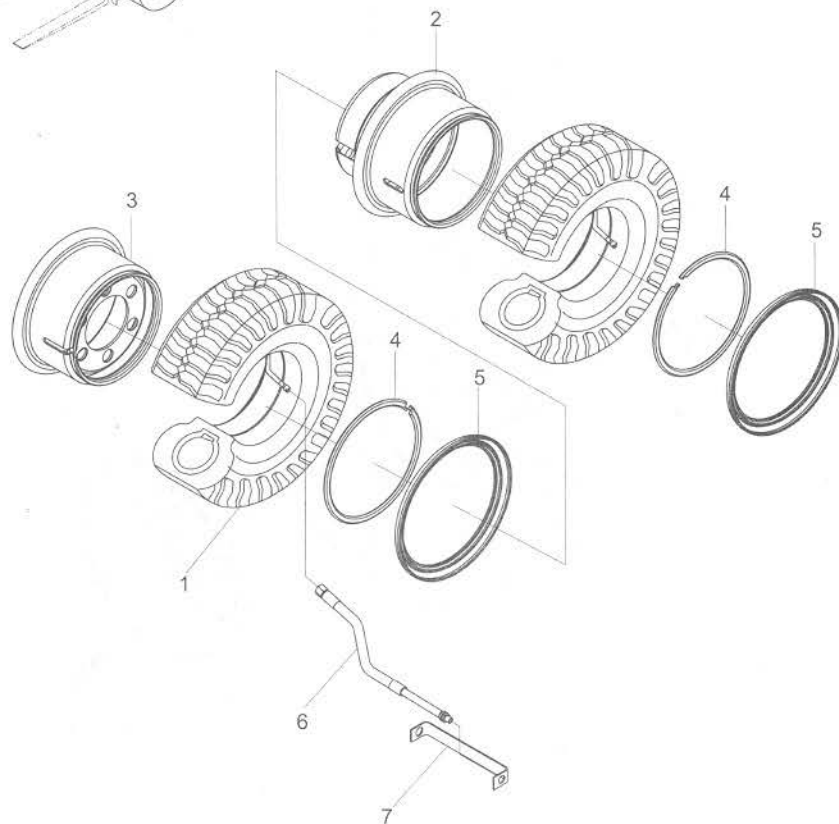
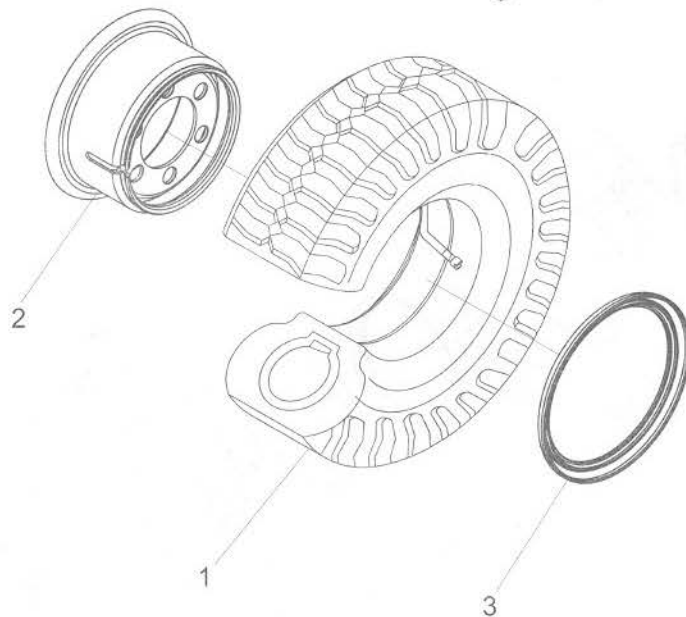
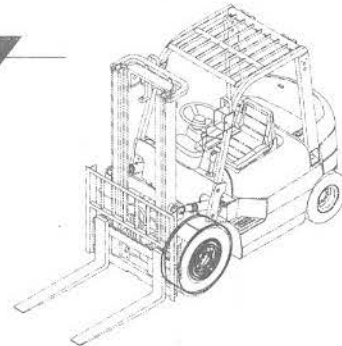
CPC, CPCD30,35
CPQ, CPQD30,35

C

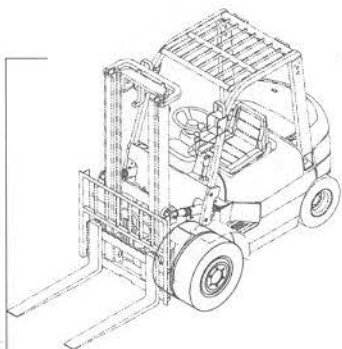

CPC, CPCD30, 35
CPQ, CPQD30, 35

序号 Item No	图号 Part No	零部件名称 Description	件数 Q'ty	备注 Remark
01	Z3104-90015	Tyre 轮胎28X9-15-12PR	4	GB/T2982-2001
-	Z3300-90015	Solid tyre 实心轮胎28X9-15	4	GB10823-89
A	24454-40222G	Wheel rim ass'y(Inc.2,4) 轮辋总成	2	
B	54456-80221G	Wheel rim ass'y(Inc.3,4) 双胎轮辋总成	2	
02	24439-44032G	Wheel rim 轮辋体总成(7.00T-15)	2	
03	24463-01000G	Wheel rim 轮辋总成(7.00T-15)	2	
04	24454-42002G	Snap ring 挡圈(7.00T-15)	4	
05	25783-02240	Pipe 充气接管	2	
06	24493-04000G	Bracket 支架	2	左右对称各一 Left & right types



图81/FIG81

轮式制动器/WHEEL BRAKE (2, 2.5t)

C24

序号 Item No	图号 Part No	零部件名称 Description	件数 Q'ty	备注 Remark
A	REF000560*L	Wheel brake ass'y(L.H.)制动器总成(左)	1	
-	REF000560*R	Wheel brake ass'y(R.H.)制动器总成(右)	1	
01	22493-71100G	Back plate 制动器底板	1	左右对称各一 Left & right types
02	22493-72010G	Adjuster cover 间隙调整套	1	左右旋螺纹各一 Left & right threads
03	23653-73021	Brake shoe 摩擦片总成	2	
04	24433-70160G	Spring shim 弹性垫片	1	
05	23653-72071G	Lever LH brake 手制动拉杆	1	左右对称各一 Left & right types
06	23673-72261	Spring, shoe return 回位弹簧	2	
07	23653-72131	Plate, shoe guide 垫片	1	
08	23653-72161	Stopper, pole lever 顶杆	1	
09	23653-72171	Spring, actuator 回位弹簧	1	
10	23653-72081	Strut 手制动推杆	1	
11	22673-72391	Spring 压缩弹簧	1	
12	23653-72151	Lever L.H pole 调整杠杆	1	左右对称各一 Left & right types
13	23653-72191	Washer, cup 压簧座	3	
14	23653-72051	Spring 弹簧	1	
15	23653-72111	Washer, cup 压簧盖	4	
16	23653-72091	Spring 弹簧	4	
17	23653-72121	Washer, cup 压簧座	1	
18	23653-72101	Pin, shoe hold 压簧拉杆	4	
19	22673-72231	Pin, lever 支撑销	1	
20	22673-72251	Shim 垫片	1	
21	22673-72321	Plug, rubber 胶堵	1	
22	OC11246-14603	Cable L.H. 制动钢索总成(左)	1	
-	OC11246-24603	Cable R.H. 制动钢索总成(右)	1	
23	B0322-08016	Bolt 螺栓M8X16	2	GB5783-86
24	B5050-00008	Washer, lock 垫圈	2	GB93-87
B	22673-72041	Wheel cylinder ass'y(Inc.25~34)制动分泵总成	1	左右对称各一 Left & right types
25	22673-72061a	Body 制动分泵缸	1	左右对称各一 Left & right types
26	22673-72101	Cover, dust 制动分泵护罩	2	

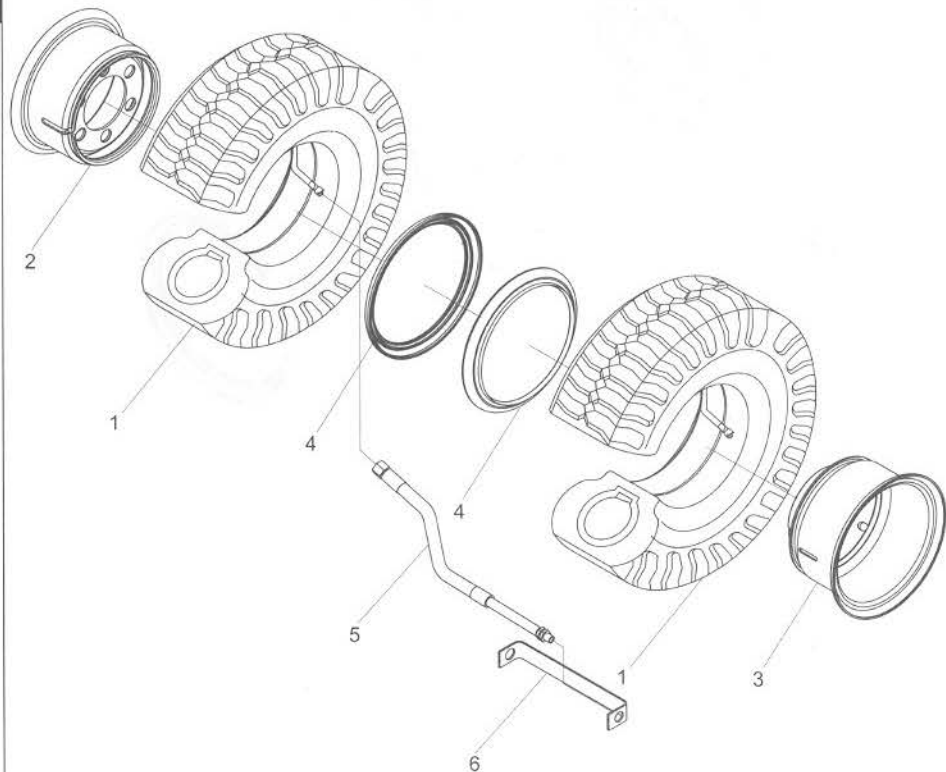
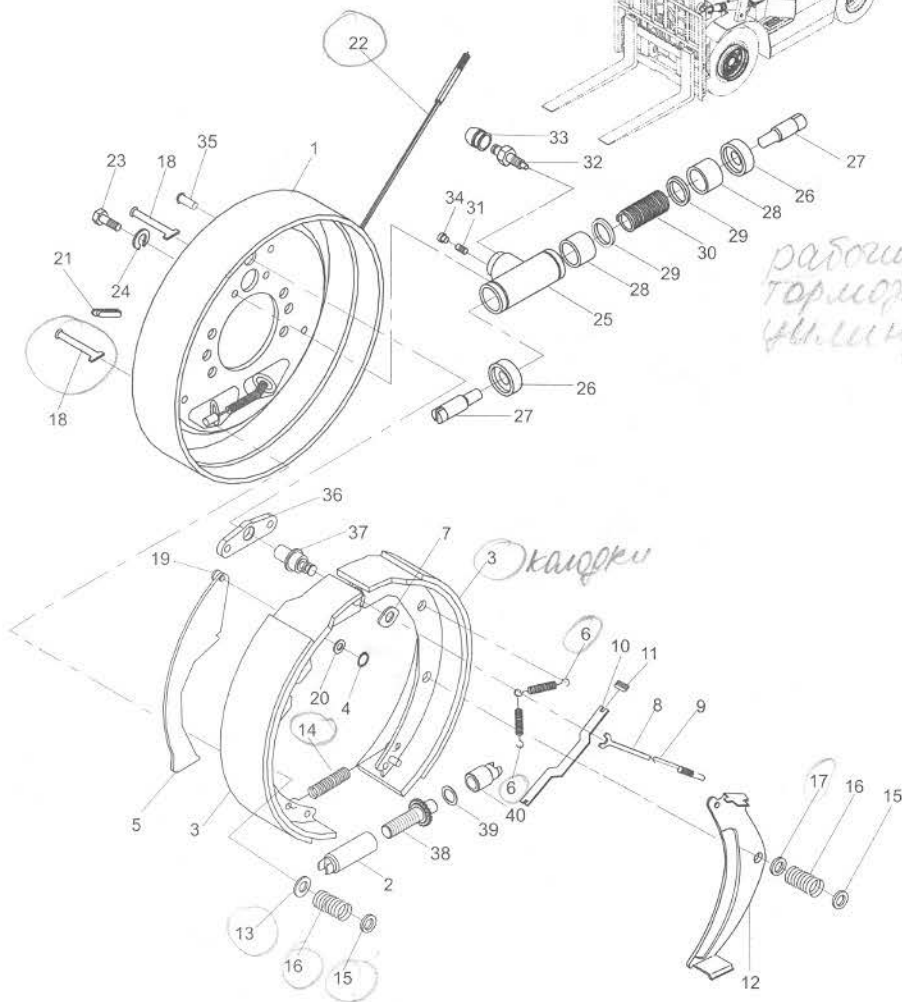

C24

轮式制动器/WHEEL BRAKE (2, 2.5t)

图81/FIG81

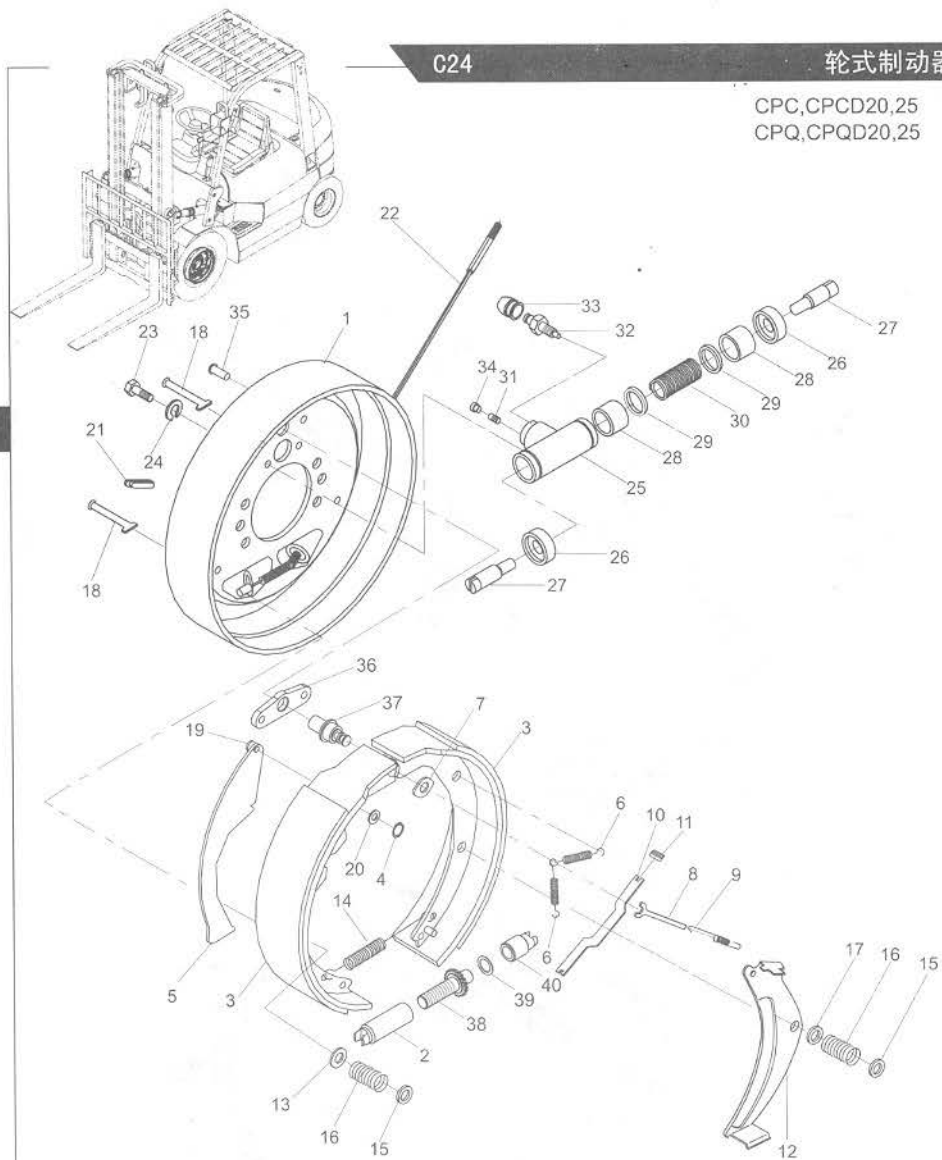
CPC, CPCD20,25
CPQ, CPQD20,25序号
Item
No图号
Part No零部件名称
Description件数
Q'ty备注
Remark

序号 Item No	图号 Part No	零部件名称 Description	件数 Q'ty	备注 Remark
27	22673-72111	Rod, piston	2	制动分泵活塞顶杆
28	22673-72071	Piston	2	活塞
29	22673-72081G	Cup, piston	2	分泵皮碗
30	22673-72091	Spring	1	制动分泵弹簧
31	24433-76070G	Seat,tube	1	制动分泵油塞
32	22673-72131	Screw, bleader	1	制动分泵放气螺钉
33	22673-72141	Cap, screw	1	分泵放气螺钉护罩
34	22492-74010G	Cap, dust	1	防尘盖
35	22493-71020G	Rivet	2	铆钉
36	22493-71010G	Plate	1	垫板
37	22493-71030G	Pin	1	支撑销
38	22493-72020G	Adjuster bolt	1	间隙调整螺栓
39	B5310-00010	Washer	10	垫圈
40	22493-72030G	Adjuster staff	1	间隙调整杆

左右旋螺纹各一
Left & right threads

图82/F1G82

轮式制动器/WHEEL BRAKE (3t, 3.5t)

C25

序号 Item No	图号 Part No	零部件名称 Description	件数 Q'ty	备注 Remark
A	REF000567 24453-70411	Wheel brake ass'y(L.H.) 制动器总成(左)	1	
-	REF000567 24453-70401	Wheel brake ass'y(R.H.) 制动器总成(右)	1	
B	24433-76000G	Wheel cylinder ass'y(Inc.1~10) 制动分泵总成	1	
01	24433-76010G	Cylinder 制动分泵缸	1	
02	24433-76020G	Piston 分泵活塞	2	
03	24433-76030G	Cup, piston 分泵皮碗	2	
04	24433-76040G	Spring 分泵弹簧	1	
05	22673-72101	Cover, dust 分泵护罩	2	
06	24433-76060G	Rod, piston 分泵活塞顶杆	2	
07	24433-76070G	Plug 制动分泵油塞	1	
08	24433-76080G	Shroud 螺纹防护罩	1	
09	24433-76090G	Screw, breather 分泵放气螺钉	1	
10	24453-76100G	Cap, screw 分泵放气螺钉帽	1	
11	24433-71000G	Pin, shoe & lining ass'y 制动蹄带摩擦片总成(前)	1	
12	24433-75000G	Pin, shoe & lining ass'y 制动蹄带摩擦片总成(后)	1	
13	24433-72100G	Back plate 底板总成	1	左右对称各一 Left & right types
14	24433-74010G	Adjuster cover 间隙调整套	1	左右旋螺纹各一 Left & right threads
15	24433-73000G	Spring & Fitting ass'y 弹簧拉线装置	1	
16	24433-70010G	Pin, shoe hold down 压簧拉杆	2	
17	24433-70020G	Cup, shoe hold down 压簧座	4	
18	24433-70030G	Spring, shoe hold down 压簧	2	
19	24433-70040G	Cover, adjusting hole 胶堵	1	
20	24433-70050G	Spring shoe 回位弹簧	1	
21	24433-70070G	Guide plate 导向板	1	
22	24433-70060G	Retrun spring, brake shoe 制动蹄回位弹簧	2	
23	24433-70080G	Guide, cable 导向块	1	
24	24433-70090G	Spring 弹簧	1	左右对称各一 Left & right helical types
25	24433-70100G	Lever 棘爪	1	左右对称各一 Left & right types
26	24433-70110G	Pin 销钉	1	
27	24433-70120G	Strut L.H. 手制动推杆	1	左右对称各一 Left & right types

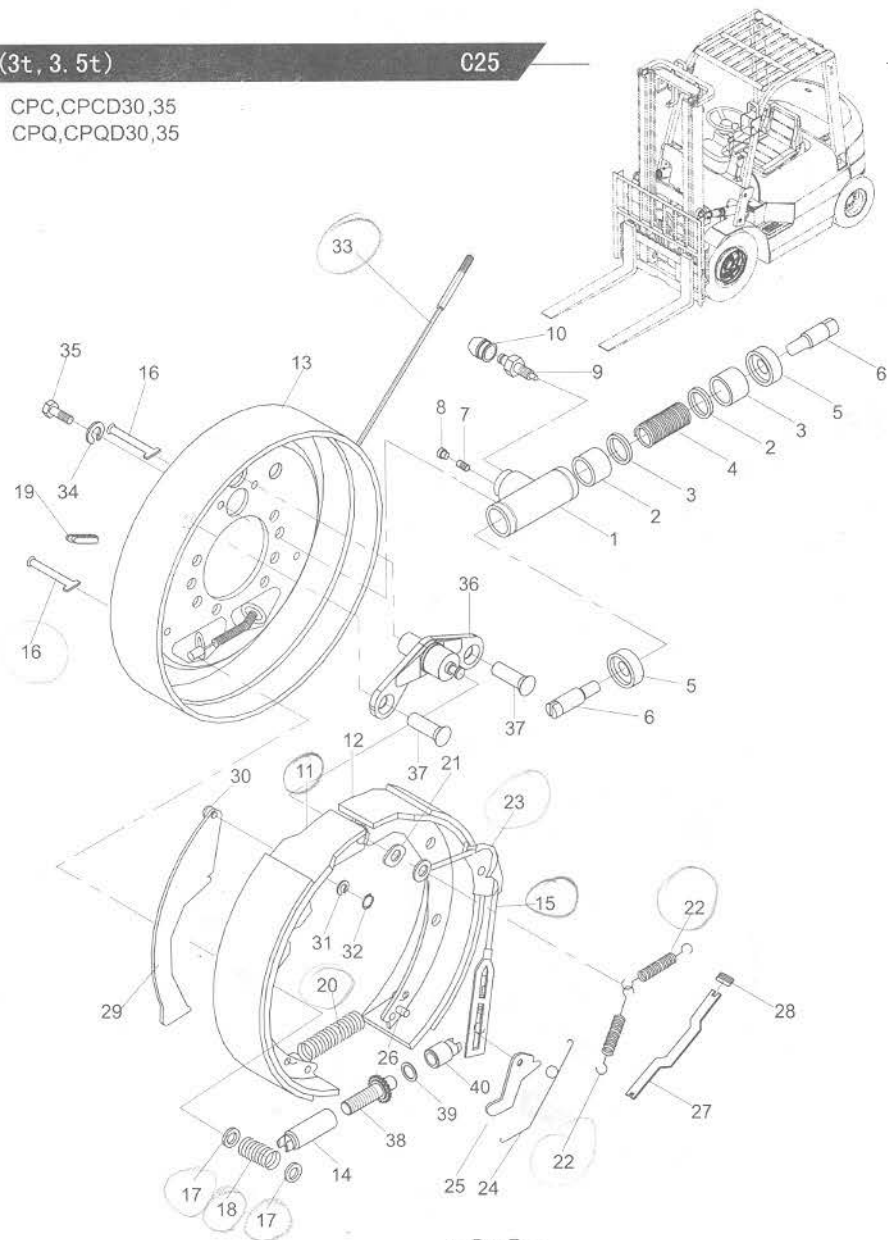

CPC, CPCD30, 35
CPQ, CPQD30, 35

序号 Item No	图号 Part No	零部件名称 Description	件数 Q'ty	备注 Remark
28	24433-70130G	Spring	1	弹簧
29	24433-70140G	Rod	1	手制动拉杆 左右对称各一 Left & right types
30	24433-70150G	Pin	1	销钉
31	24433-70160G	Washer, spring	1	弹性垫片
32	24433-70170G	Snap, ring, pin axle	1	杆销挡圈
33	OC11246-14603	Cable L.H.	1	制动钢索总成(左)
-	OC11246-24603	Cable R.H.	1	制动钢索总成(右)
34	B5050-00008	Washer, lock	2	垫圈8 GB93-87
35	B0330-08020	Bolt	2	螺栓M8X20 GB5783-86
36	24433-72020G	Pin	1	支承销
37	24433-72010G	Rivet	2	沉头铆钉
38	24433-74020G	Adjuster bolt	1	间隙调整螺丝 左右旋螺纹各一 Left & right threads
39	24433-74030G	Washer	10	垫圈10
40	24433-74040G	Adjuster staff	1	间隙调整杆



图83/FIG83

变速箱变速操纵(液力式)/TRANSMISSION CONTROL LINKAGE (TOR-CON TYPE)

C26

序号 Item No	图号 Part No	零部件名称 Description	件数 Q'ty	备注 Remark
01	A24K3-90011	Knob	手柄	1
02	B4313-00010	Nut	螺母M10×1.5	1 GB6172-86
03	H25S3-90201	Lever	操纵杆总成	1
04	A24K3-90031	Bracket(left)	支架(上)	1
05	B0320-08025	Bolt	螺栓M8×25	4 GB5783-86
06	B5050-00008	Washer	垫圈8	7 GB93-87
07	B0320-06012	Bolt	螺栓M6×12	2 GB5783-86
08	B5050-00006	Washer	垫圈6	2 GB93-87
09	A24K3-90041	Shaft	销轴总成	2
10	H25S3-90301	Link	连杆	1
11	B3220-08018	Pin	销轴8×18	2 GB882-86
12	B3010-3P220	Pin	开口销3.2×20	2 GB91-86
13	B5320-00008	Washer	垫圈8	2 GB97.1-85
14	A24K3-90071	Bracket(lower)	支架(下)	1
15	H25S3-90501	Boss	摇臂总成	1
16	HRA24K3901 A24K3-98041	Link	连杆	1
17	B4323-10008	Nut(left)	螺母M8(左)	1 GB6172-86
18	HRA23F3906/ 24357-42121G	Bearing	弯杆型球头杆端关节轴承	1
19	B4132-10008	Nut(left)	螺母M8(左)	4 GB6170-86
20	H25S3-90401	Link	连杆	1
21	B0320-08035	Bolt	螺栓M8×35	1 GB5783-86
22	HRA23F3906/ 24357-42111G	Bearing	弯杆型球头杆端关节轴承	1

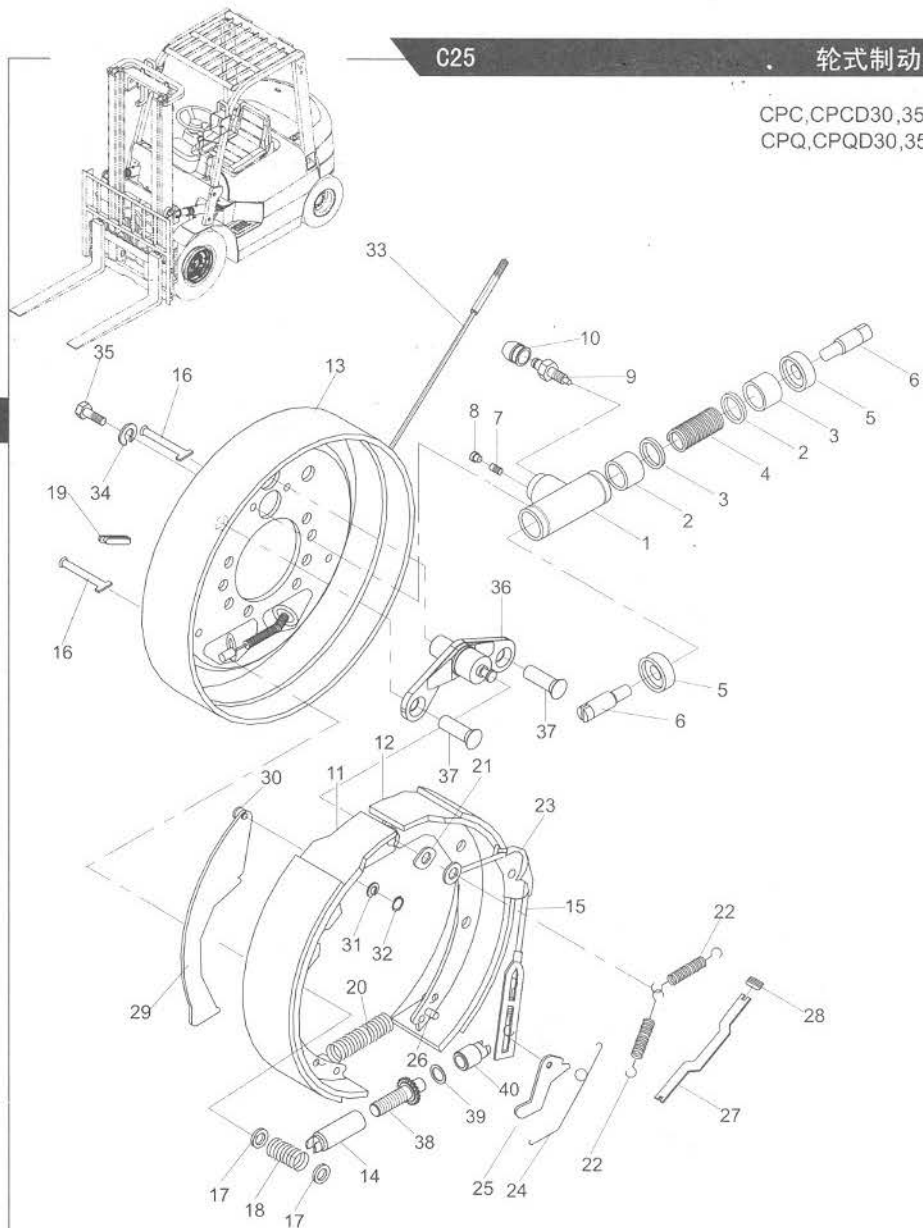
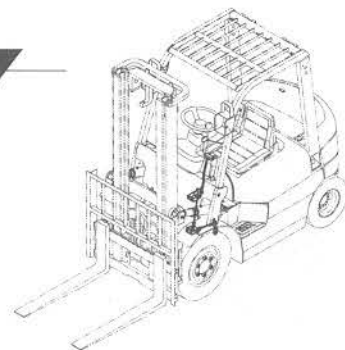
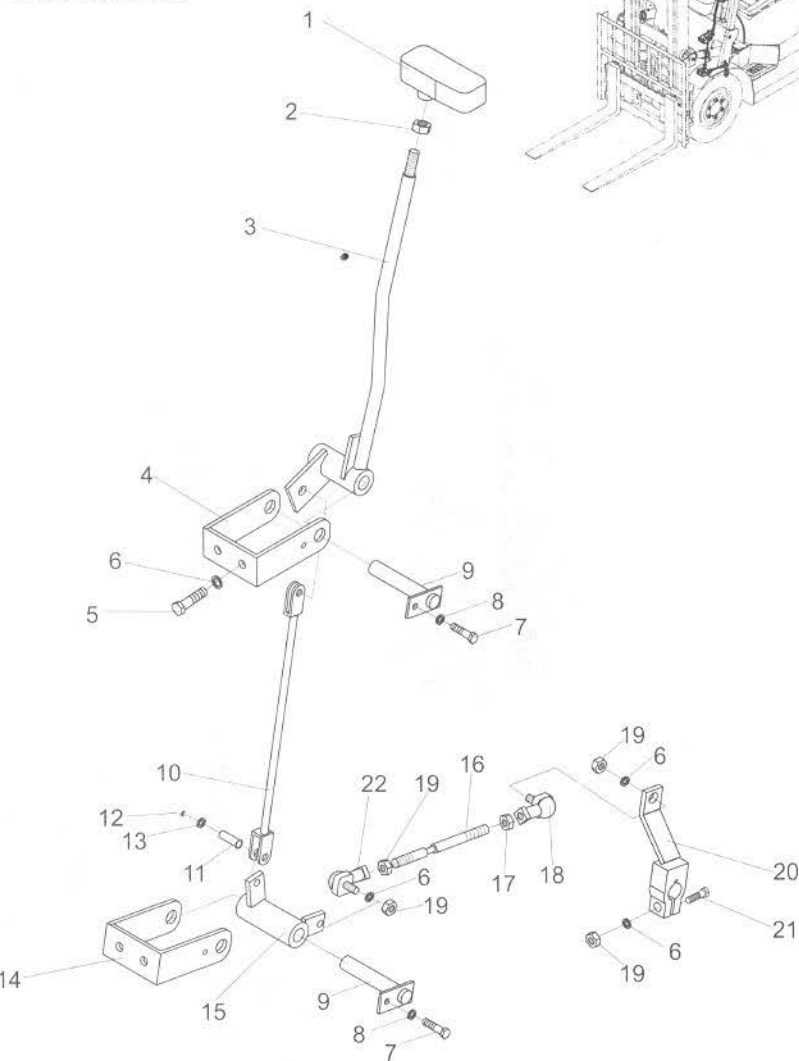

CPC, CPCD20, 25, 30, 35
CPQ, CPQD20, 25, 30, 35

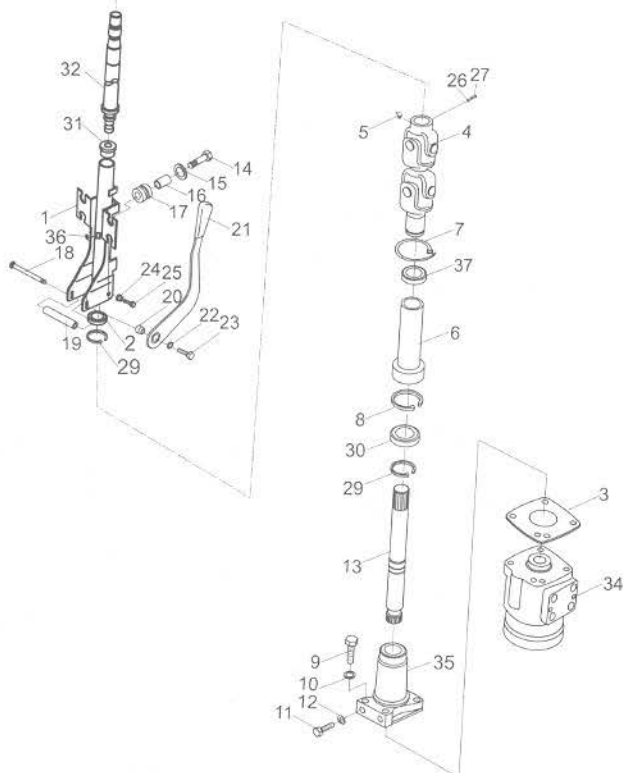
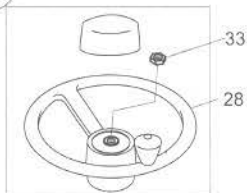
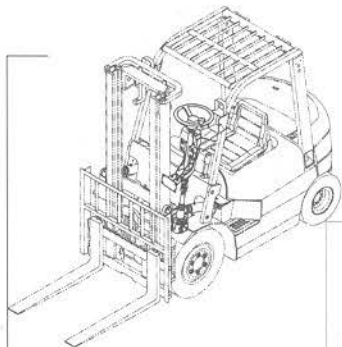

序号 Item No	图号 Part No	零部件名称 Description	件数 Qty	备注 Remark	
01	H24C4-10211	Column	转向管柱	1	
02	Z-61904-Z	Bearing	轴承61904-Z	1	GB/T276-94
03	H24C4-12231	Shim	调整垫	1	
04	H24C4-10301	Joint	万向节总成	1	
05	Z2500-01010	Titting,grease	油杯 M10×1	1	GB1152-85
06	H24C4-12101	Boot	护套	1	
07	ZD-04015	Band	捆扎带 ZD4X150	1	
08	B6050-00037	Snap ring	挡圈37	1	GB893.1-86
09	B0230-10045	Bolt	螺栓 M10×45	4	GB5782-86
10	B5050-00010	Washer	垫圈10	4	GB93-87
11	B0330-12025	Bolt	螺栓 M12×25	2	GB5783-86
12	B5050-00012	Washer	垫圈12	2	GB93-87
13	H24C4-12111	Link	连接轴	1	
14	B0230-06035	Bolt	螺栓 M6×35	4	GB5782-86
15	H24C4-12131	Washer	垫片	4	
16	A22A4-12141	Spacer	套管	4	
17	A22A4-12101	Rubber	橡胶套	4	
18	H24C4-12151	Bolt (left)	螺栓(左旋)	1	
19	H24C4-12161	Spacer	套管	1	
20	H24C4-12171	Nut	螺母	1	
21	H24C4-10501	Lever	手柄总成	1	
22	B5210-00010	Washer	垫圈10	1	GB96-85
23	H24C4-12191	Bolt (left)	螺栓 M10×16(左旋)	1	
24	H24C4-12211	Washer	垫圈	2	
25	H24C4-12221	Bolt	螺栓	2	
26	B5050-00008	Washer	垫圈8	1	GB93-87
27	B0230-08035	Bolt	螺栓M8X35	1	GB5782-86
28	A22A4-11102	Handle Shaft Ass'y	方向盘总成	1	
-	A22A4-19101	Handle Shaft Ass'y	方向盘总成	1	选用 Optin
29	B6152-00020	Snap ring	弹簧挡圈20	2	GB894.1-86

图84/FIG84

转向系统/STEERING SYSTEM

D1

序号 Item No	图号 Part No	零部件名称 Description	件数 Q'ty	备注 Remark
30	Z-61904-2Z	Bearing 轴承61904-2Z	1	GB/T276-94
31	A22A2-46001	Spacer Ass'y 上衬套总成	1	
32	A73J4-12052	Shaft 转向轴	1	
33	B4423-00016	Nut 螺母M16X1.5	1	GB6173-865
34	502-1302	Orbitrol 摆线全液压转向器BZZ-100	1	
35	H24C4-12121	Flange 连接法兰	1	
36	AO1D4-12021	Grommet 喇叭线套	1	
37	H24C4-12251	Seal,oil 旋转轴骨架油封GP20x38x8	1	

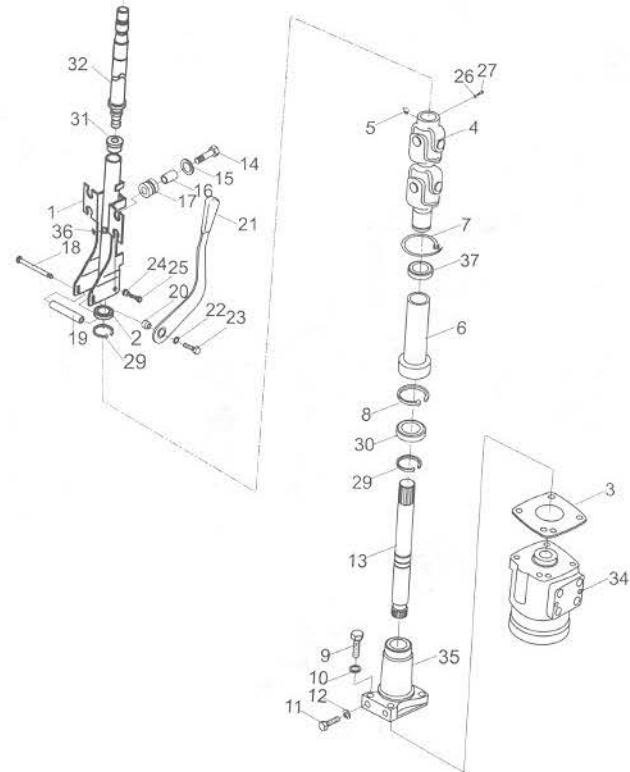
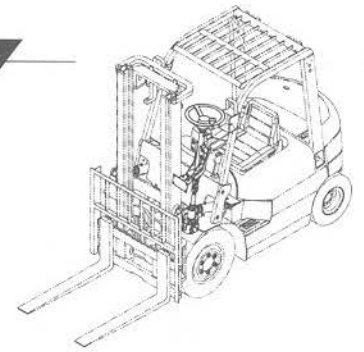
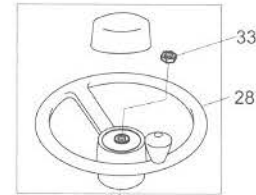
CPC, CPCD20, 25, 30, 35
CPQ, CPQD20, 25, 30, 35

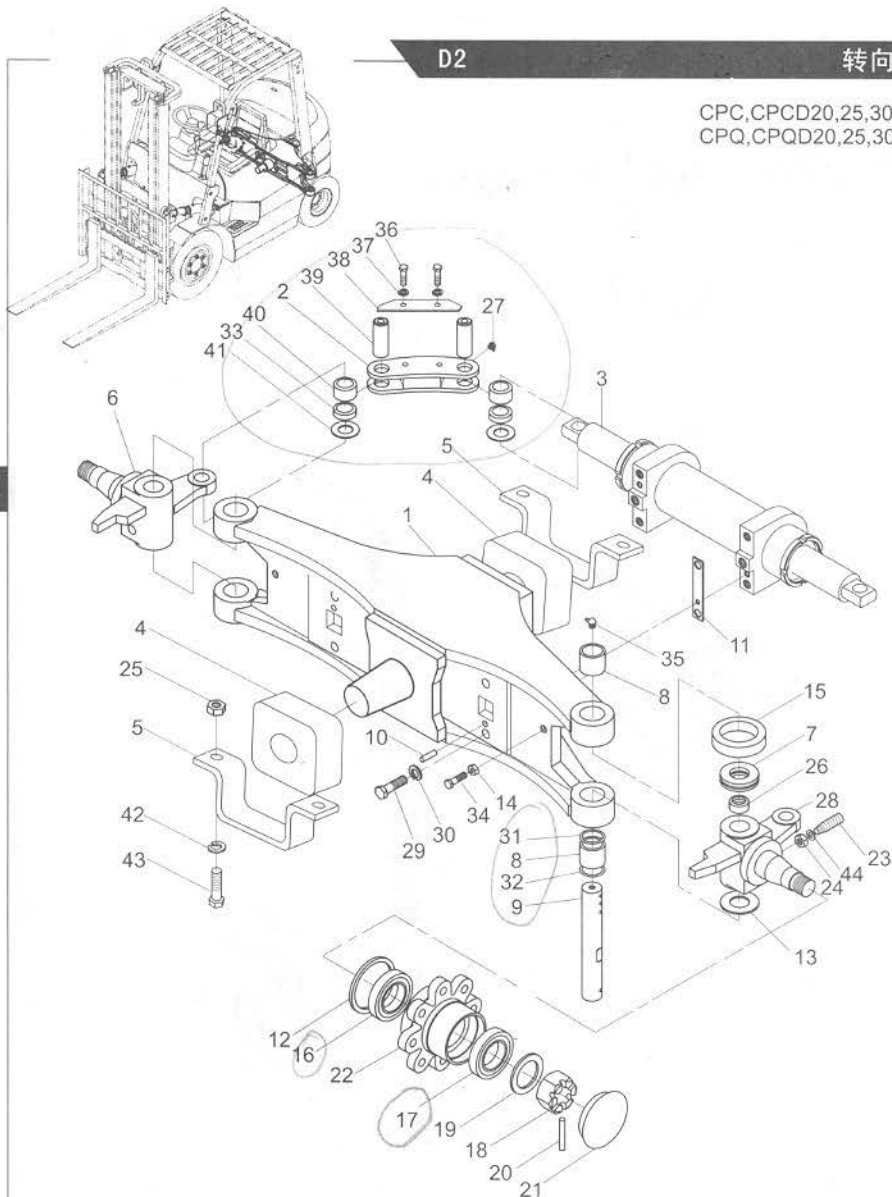
CPC, CPCD20, 25, 30, 35
CPQ, CPQD20, 25, 30, 35

序号 Item No	图号 Part No	零部件名称 Description	件数 Q'ty	备注 Remark
01	H24N4-30302	Axle ass'y	1	转向桥体总成 3t, 3.5t
-	H95C4-30301	Axle ass'y	1	转向桥体总成 2t, 2.5t
02	A21B4-32081A	Link	2	连杆
03	H24C4-50402S	Power cylinder ass'y	1	转向油缸总成 See Fig.87
04	H24N4-32451	Rubber	2	减震块
05	H24N6-12142	Bracket	2	支架
06	H24C4-32182	Knuckle R.H. ass'y	1	右转向节总成
07	Z-51208	Bearing	2	推力轴承51208 GB/T301-93
08	Z-943/32	Bearing	4	滚针轴承943/32 GB290-89
09	A21B4-32221	Pin, king	2	转向节主销
10	B3120-10020	Pin	2	销B10X20 GB119-86
11	A21B4-32251	Shim	4	调整垫
12	Z6301-08524	U-ring	2	U型密封圈B85X110X12D GB9877.1-88
13	22214-30321	Shim	2	转向节调整垫
14	B4323-00012	Nut	18	螺母M12 GB6172-86
15	A21B4-12002	Cap	2	防尘罩
16	Z-7211E	Bearing	2	轴承7211E GB297-84
17	Z-7207E	Bearing	2	轴承7207E GB297-84
18	A21B4-32311	Nut	2	螺母M30X2
19	B5310-00030	Washer	2	垫圈30 GB97.1-85
20	B3010-63055	Pin	2	销6.3X55 GB92-86
21	A21B4-32231	Cap	2	轮毂盖
22	A21B4-32241	Hub	2	轮毂
23	20314-30616	Pin	2	紧固销
24	B4223-00010	Nut	2	螺母M10X1.25 GB6171-86
25	B4130-00016	Nut	4	螺母M16 GB6170-86
26	A21B4-12001	Bushing	2	衬套
27	Q700B06	Fitting grease	4	直通式滑脂嘴M6 ZBT33001.1-88
28	H24C4-32172	Knuckle R.H. ass'y	1	左转向节总成
29	B0220-14045	Bolt	4	螺栓M14X45 GB5782-86

图85/FIG85

转向桥/STEERING AXLE

D2

序号 Item No	图号 Part No	零部件名称 Description	件数 Q'ty	备注 Remark
30	B5050-00014	Washer,lock	垫圈14	4 GB93-87
31	23654-32161	O-ring	O形圈	2
32	23654-32081	Seal,oil	油封	2
33	H24C4-12003	Bushing	衬套	4
34	B0220-12030	Bolt	螺栓M12X30	2 GB5782-86
35	Q701B90	Fitting grease	弯颈式滑脂嘴1/8"	2 ZBT33001.2-88
36	B0010-08018	Bolt	螺栓M8X18	4 GB5780-86
37	B5050-00008	Washer,lock	垫圈8	4 GB93-87
38	A21B4-32300	Baffle	挡板	2
39	A21B4-32261A	Pin	连杆销	4
40	H24C4-32061	Bearing	ES型向心关节轴承	4
41	A21B4-32281	Shim	调整垫	4
42	B5050-00016	Washer,lock	垫圈16	4 GB93-87
43	B0230-16055	Bolt	螺栓M16X55	4 GB5782-86
44	B5310-00010	Bolt	垫圈10	2 GB97.1-85

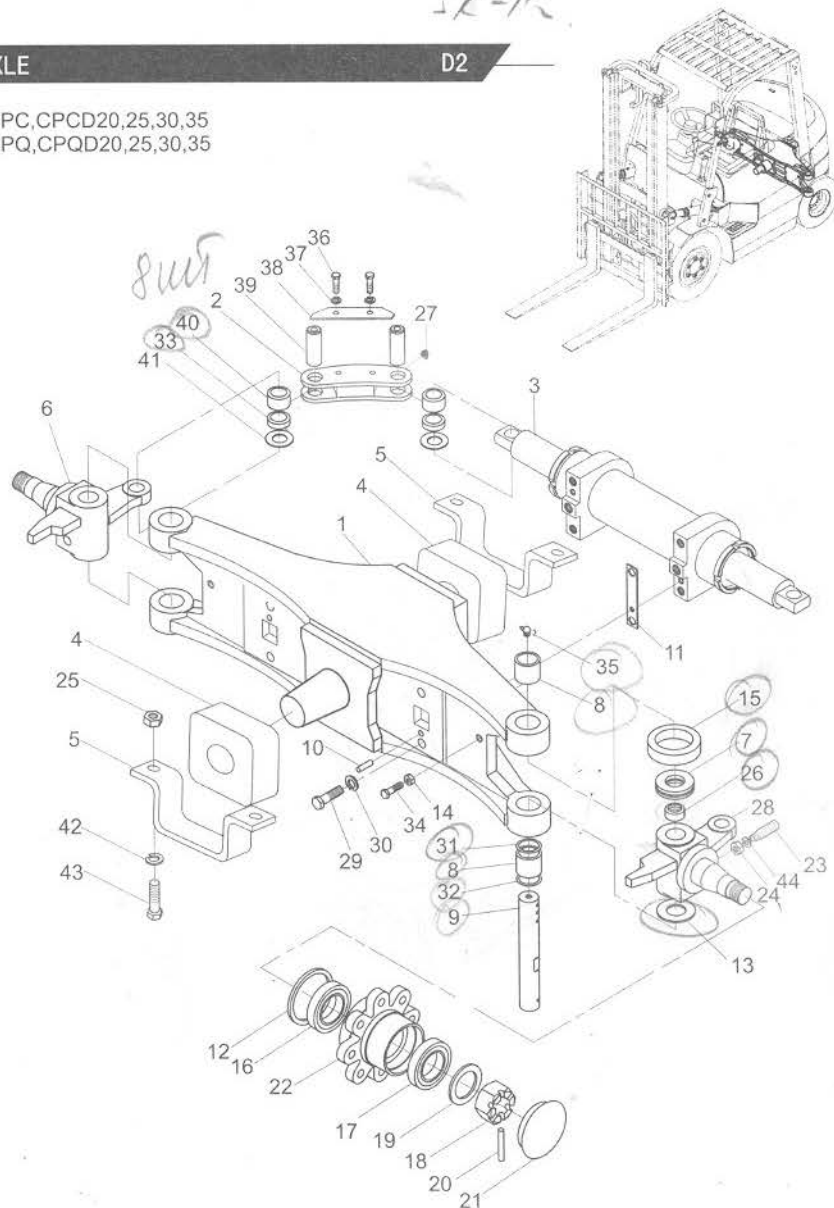
CPC,CPCD20,25,30,35
CPQ,CPQD20,25,30,35

D

D3

转向轮/ STEERING WHEEL

图86/F1886

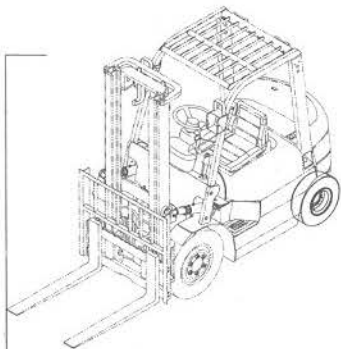
CPC, CPCD20, 25, 30, 35
CPQ, CPQD20, 25, 30, 35

序号 Item No	图号 Part No	零部件名称 Description	件数 Q'ty	备注 Remark
01	23654-43001	Rim ,inside	2	内轮辋 2-2.5t
-	22304-40312G	Rim ,inside	2	内轮辋 3t,3.5t
02	Z3003-60009	Tire	2	轮胎6.00-9-10PR 2t,2.5t GB/T 2982
-	Z3003-65010	Tire	2	轮胎6.50-10-10PR 3t,3.5t GB/T 2982
03	23654-43011G	Rim ,outside	2	外轮辋 2-2.5t
-	22304-40322G	Rim ,outside	2	外轮辋 3t,3.5t
04	23654-32041	Bolt	16	轮毂螺栓
05	23654-34051	Nut	16	轮毂螺母
06	21193-02010G	Bolt	16	轮辋螺栓
07	B4323-00012	Nut	16	螺母M12 GB6172-86
08	B5050-00012	Washer	16	垫圈12 GB93-87



图87/F1G87

转向油缸/STEERING CYLINDER

D4

序号 Item No	图号 Part No	零部件名称 Description	件数 Q'ty	备注 Remark	
A	H24C4-50402S	Steering cylinder	转向油缸	1	
01	Z1510-G0060	Steel ball	钢球 $\phi 6$	25	GB308-89
02	Z6053-05003	O-ring	O型密封圈50x3.55	3	GB3452.1-92
03	H24C4-52002S	Snap ring	孔用钢丝挡圈	2	GB/T895.2-1986
04	H24C4-52001S		肩套	2	
05	B6150-00065	Snap ring	挡圈65	2	GB/T894.1-1986
06	LBH-50	Seal,dust	防尘圈DS150X58X5/6.5	2	NOK(FQ0041D0)
07	H24C4-52153S	Piston rod	活塞杆	1	
08	Z6003-07003	O-ring	O型密封圈70x3.1	2	GB1235-76
09	24329-45591	U-ring	U型密封圈50x60x6	2	
10	22658-52301	Snap shim	挡片50x60x3	2	
11	H24C4-52171	Bearing	支承环	1	
12	60066-13030	Bearing	支承环	1	
13	H24C4-52163S	Piston	活塞	1	
14	H24C4-52003S	Cap	缸头	2	
15	H24C4-52000S	Body,cylinder	缸筒总成	1	
16	Z6053-06003	O-ring	O型密封圈60x3.55	1	GB3452.1-92

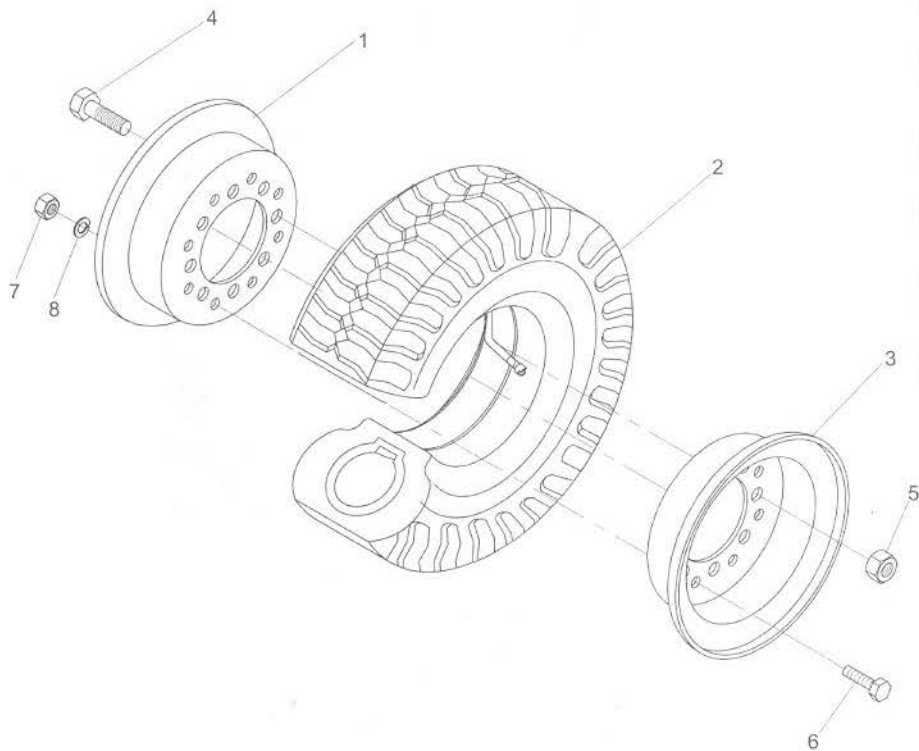
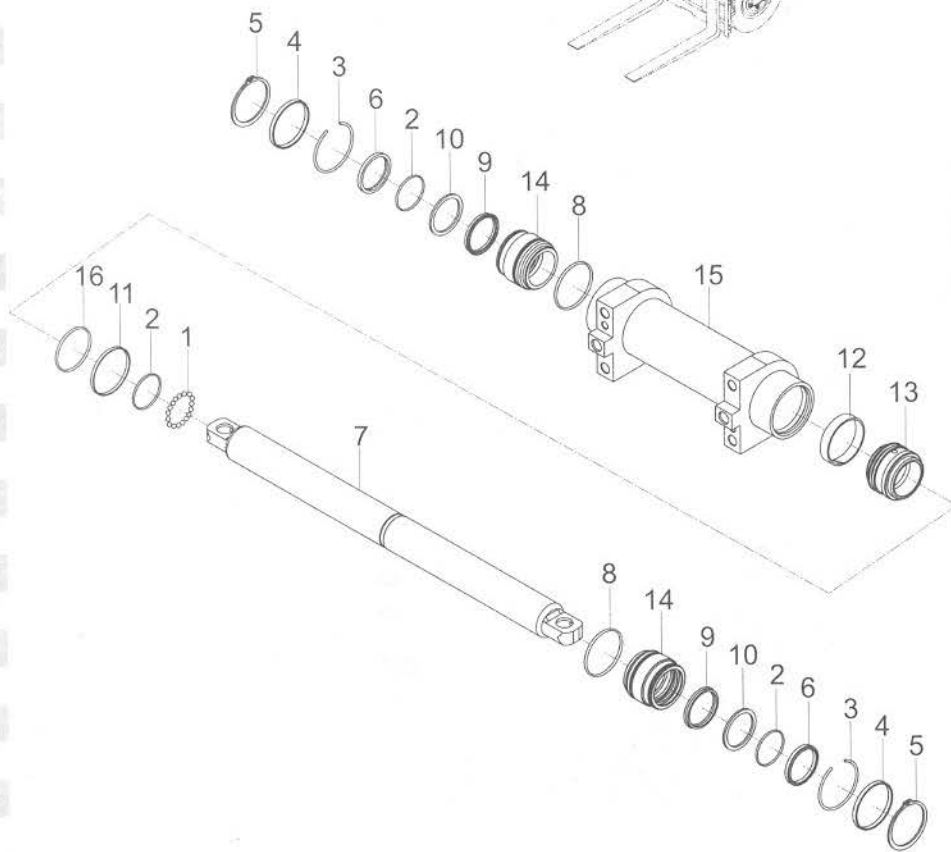
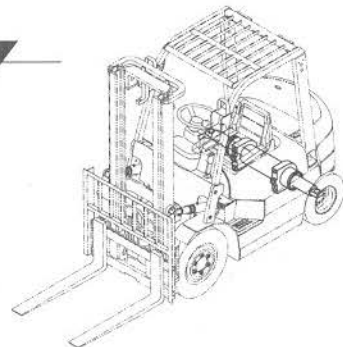
CPC, CPCD20, 25, 30, 35
CPQ, CPQD20, 25, 30, 35

D

CPQD20,25,30,35
CPCD20,25,30-W7,W8,W9,Xs1
CPCD35-W4,W5,W6,Xs1

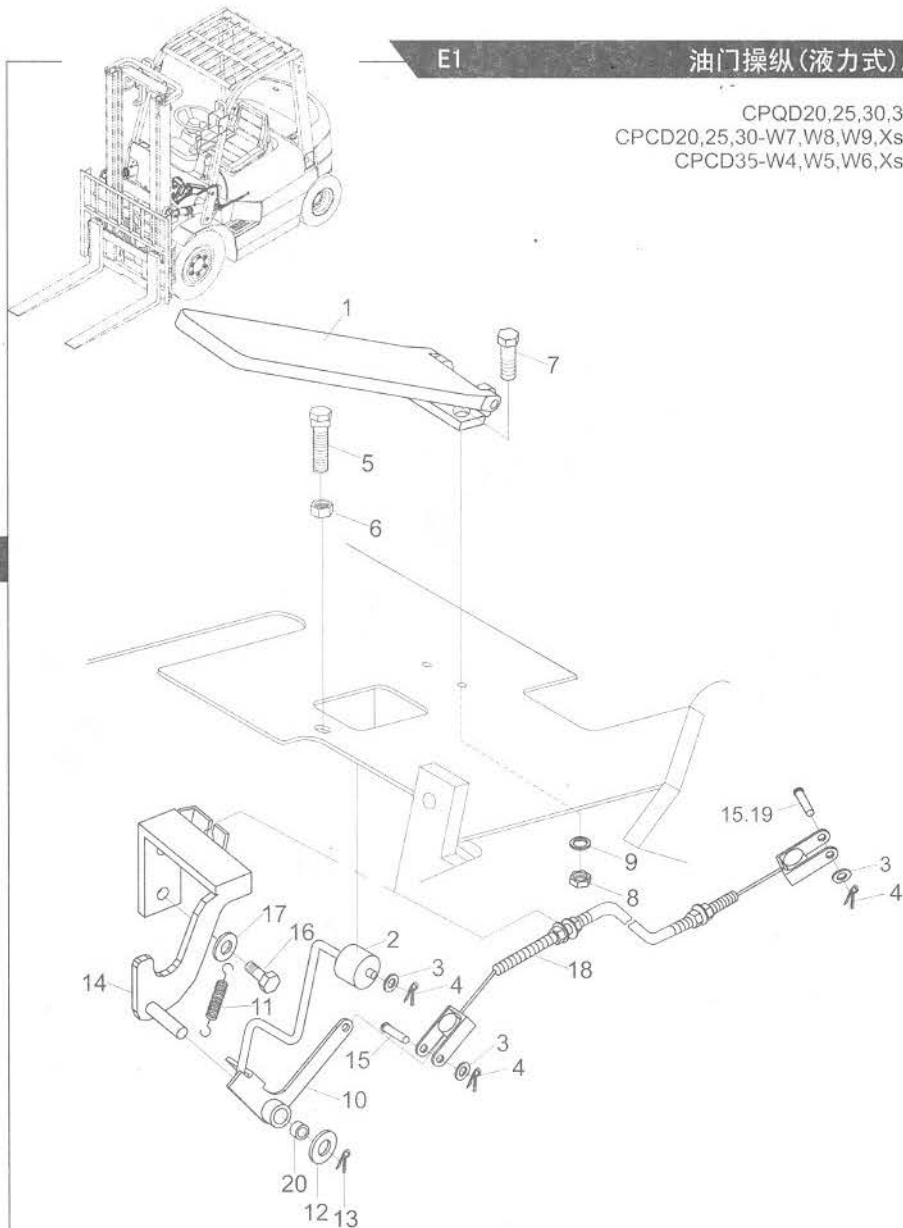

序号 Item No	图号 Part No	零部件名称 Description	件数 Q'ty	备注 Remark
01	H24C5-60201	Accelerator pedal ass'y	踏板总成	1
02	H24C5-60201	Sheave	滚轮	1
03	B5310-00006	Washer	垫圈6	1 除CPCD20~35-Xs1 外柴油车 CPQD20~35 GB97.1-85
				3 CPCD20~35-Xs1
04	B3010-02020	Pin	开口销2×20	1 CPQD20~35 GB91-86
				2 除CPCD20~35-Xs1 外柴油车
				3 CPCD20~35-Xs1
05	25785-22111	Bolt	螺栓	1
06	B4216-00012	Nut	螺母M12×1.25	1 GB6171-86
07	B0330-06020	Bolt	螺栓M6×20	2 GB5783-86
08	B4116-00006	Nut	螺母M6	2 GB6170-86
09	B5050-00006	Washer,lock	垫圈6	2 GB93-87
10	H24C5-60311	Bracket	连接轴架	1
11	25785-22031	Spring	弹簧	1
12	B5310-00010	Washer	垫圈10	1 GB97.1-85
13	B3010-3P220	Pin	销3.2×20	1 GB91-86
14	H24C5-60401	Bracket	支架	1
15	B3220-06012	Pin,axle	销轴B6×12	1 除CPCD20~35-Xs1 外柴油车 GB882-86 CPQD20~35
				2 CPCD20~35-Xs1
16	B0330-10020	Bolt	螺栓M10×20	2 GB5783-86
17	B5050-00010	Washer,lock	垫圈10	2 GB93-87
18	H24C5-60501	Soft shaft	油门拉索	1 CPQD20~35
-	H25S5-60501	Soft shaft	油门拉索	1 CPCD20~30-W7,W9 CPCD35-W5,W6
-	H25T5-60501	Soft shaft	油门拉索	1 CPCD20~30-W8 CPCD35-W4
-	H21U5-60201	Soft shaft	油门拉索	1 CPCD20~35-Xs1
19	B3220-05012	Pin,axle	销轴B5X12	1 除CPCD20~35-Xs1 外柴油车GB882-86
20	Z2131-01015	Bushing	钢背轴承1015	1

图89/FIG89

油门操纵(机械式)/ACCELERATOR PEDAL (DIESEL-CLUTCH TYPE)

E2

序号 Item No	图号 Part No	零部件名称 Description	件数 Q'ty	备注 Remark
01	H24C5-60201	Accelerator pedal ass'y	踏板总成	1
02	H24C5-62021	Sheave	滚轮	1
03	B5310-00006	Washer	垫圈6	1
				除CPC20-35-Xs1 外柴油车
				CPQ20-35 GB97.1-85
				3
				CPC20-35-Xs1
04	B3010-02020	Pin	开口销2×20	1
				CPQ20-35 GB91-86
				2
				除CPC20-35-Xs1 外柴油车
				3
				CPC20-35-Xs1
05	25785-22111	Bolt	螺栓	1
06	B4216-00012	Nut	螺母M12×1.25	1
				GB6171-86
07	B0330-06020	Bolt	螺栓M6×20	2
				GB5783-86
08	B4116-00006	Nut	螺母M6	2
				GB6170-86
09	B5050-00006	Washer, Lock	垫圈6	2
				GB93-87
10	H24C5-60611	Bracket	连接轴架	1
11	25785-22031	Spring	弹簧	1
12	B5310-00010	Washer	垫圈10	1
				GB971-85
13	B3010-3P220	Pin	销3.2×20	1
				GB91-86
14	H24C5-60701	Bracket	支架	1
15	B3220-06012	Pin, axle	销轴B6×12	1
				除CPC20-35-Xs1 外柴油车
				CPQ20-35 GB882-86
				2
				CPC20-35-Xs1
16	B0330-10020	Bolt	螺栓M10×20	2
				GB5783-86
17	B5050-00010	Washer, lock	垫圈10	2
				GB93-87
18	H24C5-60501	Soft shaft	油门拉索	1
				CPQ20-35
-	H25S5-60501	Soft shaft	油门拉索	1
				CPC20-30-W7,W9 CPC35-W5,W6
-	H25T5-60501	Soft shaft	油门拉索	1
				CPC20-30-W8 CPC35-W4
-	H21U5-60201	Soft shaft	油门拉索	1
				CPC20-35-Xs1
19	B3220-05012	Pin, axle	销轴B5X12	1
				除CPC20-35-Xs1 外柴油车GB882-86
20	Z2131-01015	Bushing	钢背轴承1015	1

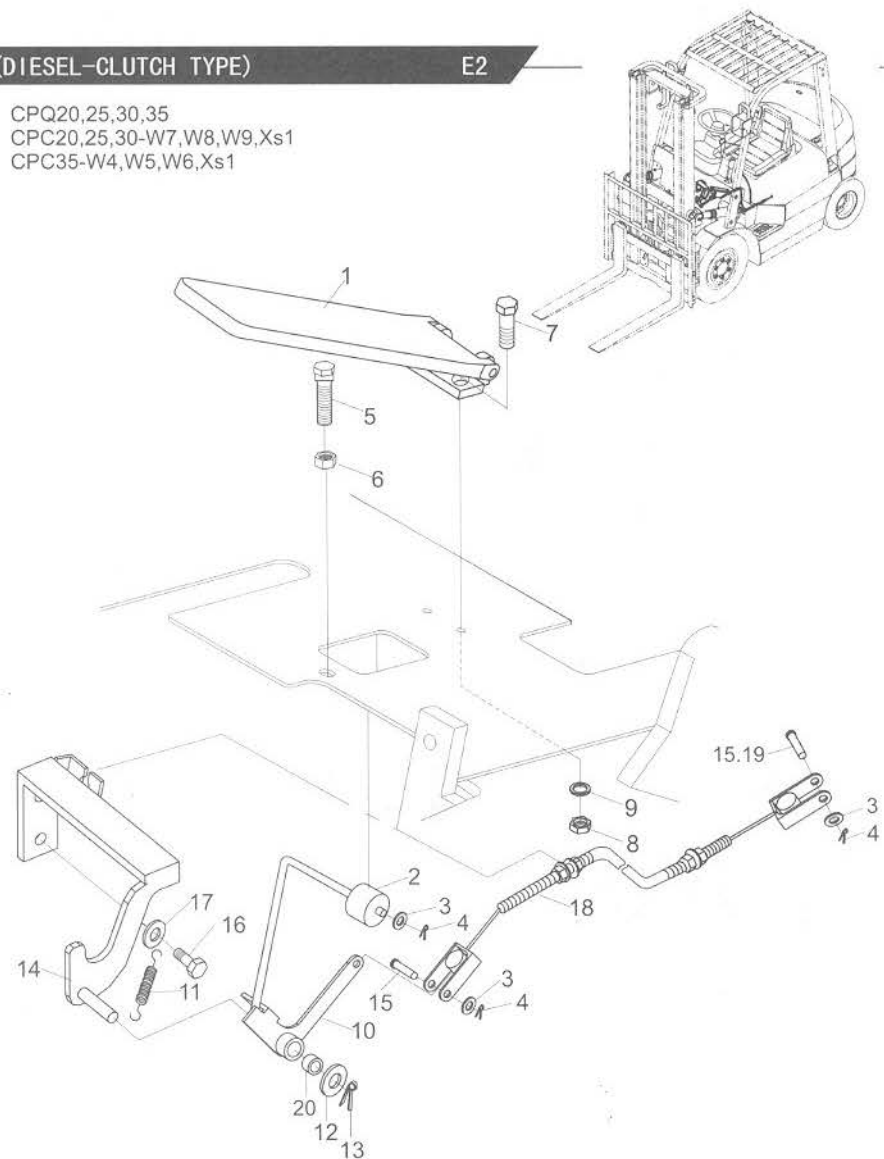

CPC,CPCD20,25,30-X6
CPC,CPCD35-X2

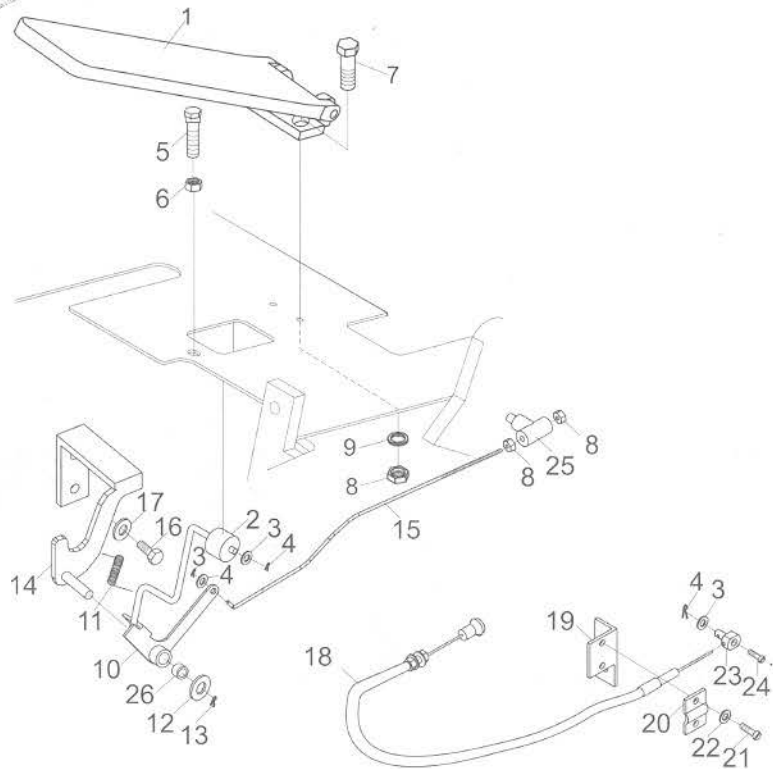
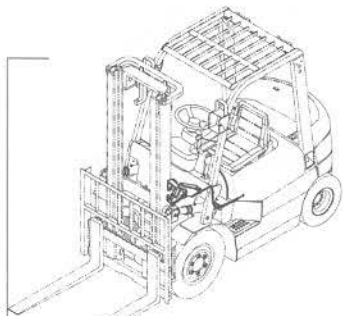

序号 Item No	图号 Part No	零部件名称 Description	件数 Qty	备注 Remark
01	H24C5-60201	Accelerator pedal ass'y	踏板总成	1
02	H24C5-62021	Sheave	滚轮	1
03	B5310-00006	Washer	垫圈6	3 GB97.1-85
04	B3010-02020	Pin	销2X20	3 GB91-86
05	25785-22111	Bolt	螺栓	1
06	B4216-00012	Nut	螺母M12X1.25	1 GB6171-86
07	B0320-06020	Bolt	螺栓M6X20	2 GB5783-86
08	B4116-00006	Nut	螺母M6	4 GB6170-86
09	B5050-00006	Washer,lock	垫圈6	2 GB93-87
10	H93C5-20211	Bracket	连接轴架	1
11	25785-22031	Spring	弹簧	1
12	B5310-00010	Washer	垫圈10	1 GB97.1-85
13	B3010-03020	Pin	销3X20	1 GB91-86
14	H93C5-20301	Bracket	支架	1
15	A97A5-22001	Link	拉杆	1
16	B0330-10020	Bolt	螺栓M10X20	2 GB5783-86
17	B5050-00010	Washer,lock	垫圈10	2 GB93-87
18	20065-23000G	Flameout control unit	熄火操纵装置	1
19	3C53-00-08	Bracket	钢丝绳固定架	1
20	3C53-00-06	Bracket	钢丝绳固定板	1
21	B1110-04016	Bolt	螺钉M4X16	2 GB67-85
22	B5050-00004	Washer,lock	垫圈4	2 GB93-87
23	20065-22000G	Pin	钢丝绳固定销	1
24	B1110-04010	Bolt	螺钉M4X10	1 GB67-85
25	3C53-00-09	Yoke	耳子	1
26	Z2131-01015	Bushing	钢背轴承1015	1

图91/FIG91

油门操纵/ACCELERATOR PEDAL

E4

序号 Item No	图号 Part No	零部件名称 Description	件数 Q'ty	备注 Remark
A	H99Y5-20001	Accelerator pedal 油门操纵装置	1	
01	H24C5-60201	Accelerator pedal ass'y 踏板总成	1	
02	H24C5-62021	Trolley 滚轮	1	
03	B5310-00006	Washer 垫圈6	3	GB97.1-85
04	B3010-02020	Pin,snap 销2X20	3	GB91-86
05	25785-22111	Bolt 螺栓	1	
06	B4216-00012	Nut 螺母M12X1.25	1	GB6171-86
07	B0320-06020	Bolt 螺栓M6X20	2	GB5783-86
08	B4116-00006	Nut 螺母M6	2	GB6170-86
09	B5050-00006	Washer,lock 垫圈6	2	GB93-87
10	H24C5-60311	Bracket 连接轴架	1	CPCD20~35-D
-	H24C5-60611	Bracket 连接轴架	1	CPC20~35-D
11	25785-22031	Spring 弹簧	1	
12	B5310-00010	Washer 垫圈10	1	GB97.1-85
13	B3010-03020	Pin,snap 销3X20	1	GB91-86
14	H24C5-60401	Bracket 支架	1	CPCD20~35-D
-	H24C5-60701	Bracket 支架	1	CPC20~35-D
15	B3220-06012	Pin 销B6X12	1	GB882-86
16	B0330-10020	Bolt 螺栓M10X20	2	GB5783-86
17	B5050-00010	Washer,lock 垫圈10	2	GB93-87
18	H99Y5-20011	Soft shaft 油门拉索	1	
19	3C53-00-08	Bracket 钢丝绳固定架	1	
20	3C53-00-06	Bracket 钢丝绳固定板	1	
21	B1110-04016	Bolt 螺钉M4X16	2	GB67-85
22	B5050-00004	Washer,lock 垫圈4	2	GB93-87
23	20065-22000G	Pin 钢丝绳固定销	1	
24	B1110-04010	Bolt 螺钉M4X10	1	GB67-85
25	20065-23000G	Flameout control unit 熄火操纵装置	1	
26	Z2131-01015	Bushing 钢背轴承1015	1	

CPC,CPCD20,25,30,35-D

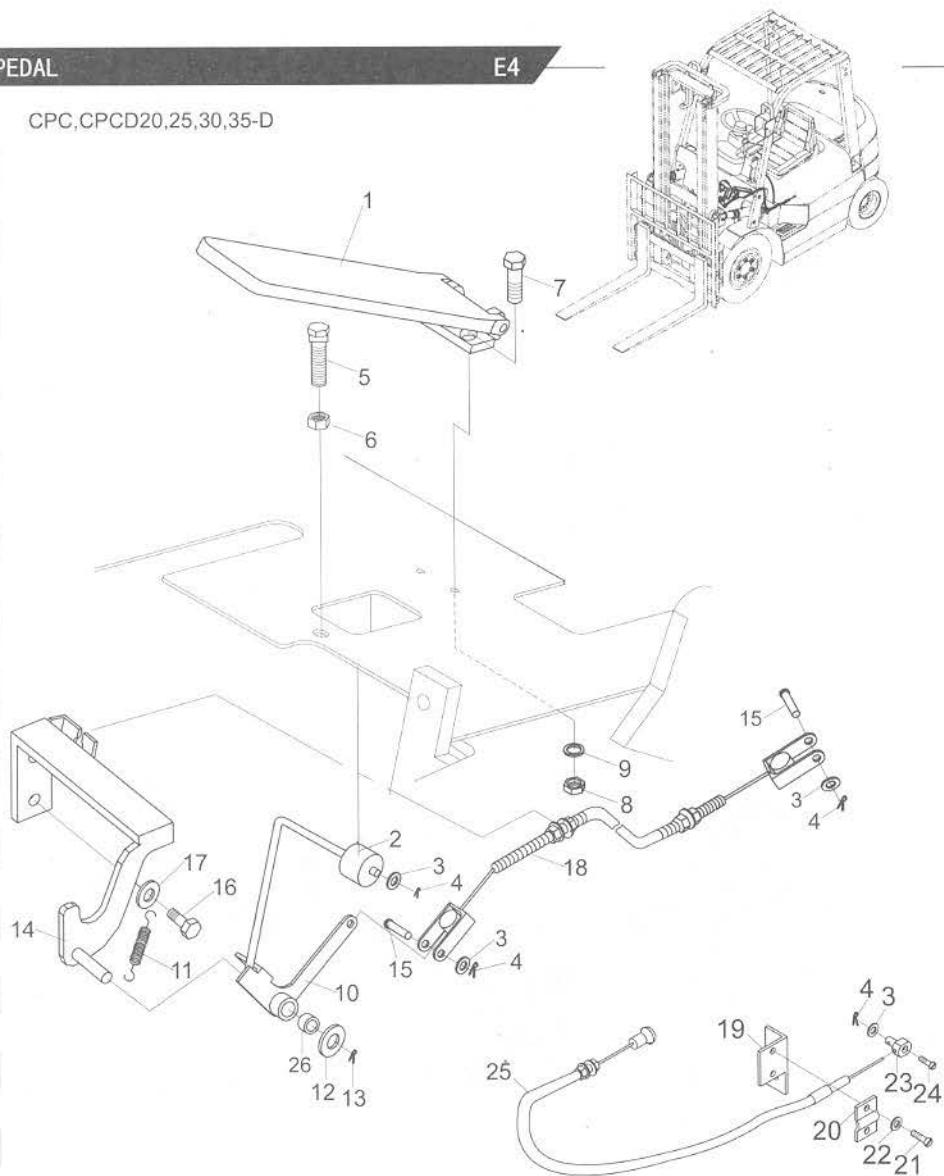

CPC,CPCD20,25,30,35-HJ

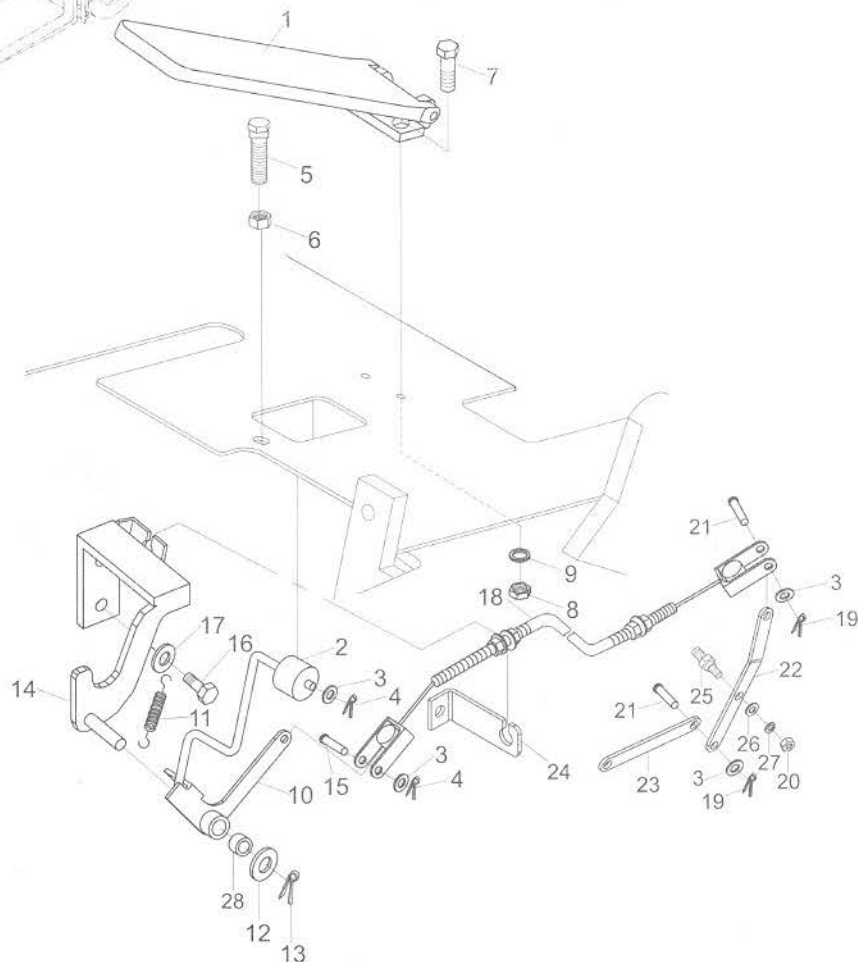
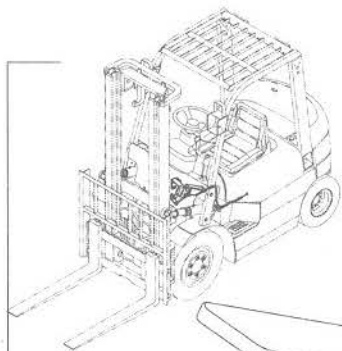

序号 Item No	图号 Part No	零部件名称 Description	件数 Q'ty	备注 Remark
01	H24C5-60201	Accelerator pedal ass'y	踏板总成	1
02	H24C5-62021	Sheave	滚轮	1
03	B5310-00006	Washer	垫圈6	4 GB97.1-85
04	B3010-02020	Pin	销2×20	1 GB91-86
05	25785-22111	Bolt	螺栓	1
06	B4216-00012	Nut	螺母M12×1.25	1 GB6171-86
07	B0320-06020	Bolt	螺栓M6×20	2 GB5783-86
08	B4116-00006	Nut	螺母M6	2 GB6170-86
09	B5050-00006	Washer,lock	垫圈6	2 GB93-87
10	H24C5-60311	Bracket	连接轴架	1 CPCD20~30
-	H24C5-60611	Bracket	连接轴架	1 CPC20~30
11	25785-22031	Spring	弹簧	1
12	B5310-00010	Washer	垫圈10	1 GB97.1-85
13	B3010-03020	Pin,cotter	销3×20	1 GB91-86
14	H24C5-60401	Bracket	支架	1 CPCD20~30
-	H24C5-60701	Bracket	支架	1 CPC20~30
15	B3220-06012	Pin,axle	销B6×12	1 GB882-86
16	B0330-10020	Bolt	螺栓M10×20	2 GB5783-86
17	B5050-00010	Washer,lock	垫圈10	2 GB93-87
18	H97Y5-20011	Soft shaft	油门拉索	1
19	B3030-02020	Pin,cotter	销2X20	3 GB91-86
20	B4123-00004	Nut	螺母M4	1 GB6170-86
21	B3220-06012	Pin,axle	销B6X12	3 GB882-86
22	P62A5-22111	Link	摇臂	1
23	P62A5-22121	Link	摇臂	1
24	P62A5-22131	Clip	夹板	1
25	P62A5-22141	Bolt	螺栓	1
26	B5713-00004	Washer	垫圈4	1 GB848-85
27	B5050-00004	Washer,lock	垫圈4	1 GB93-87
28	Z2131-01015	Bushing	钢背轴承1015	1

图93/FIG93

油门操纵/ACCELERATOR PEDAL

E6

序号 Item No	图号 Part No	零部件名称 Description	件数 Q'ty	备注 Remark
A	H2B95-60001	Accelerator pedal 油门操纵装置	1	
01	H24C5-60201	Accelerator pedal ass'y 踏板总成	1	
02	H24C5-62021	Sheave 滚轮	1	
03	B5310-00006	Washer 垫圈6	2	GB97.1-85
04	B3010-02020	Pin 销2×20	2	GB91-86
05	25785-22111	Bolt 螺栓	1	
06	B4216-00012	Nut 螺母M12×1.25	1	GB6171-86
07	B0330-06020	Bolt 螺栓M6×20	2	GB5783-86
08	B4116-00006	Nut 螺母M6	2	GB6170-86
09	B5050-00006	Washer,lock 垫圈6	2	GB93-87
10	H24C5-60311	Bracket 连接轴架	1	
11	25785-22031	Spring 弹簧	1	
12	B5310-00010	Washer 垫圈10	1	GB971-85
13	B3010-3P220	Pin 销3.2×20	1	GB91-86
14	H24C5-60401	Bracket 支架	1	
15	B3220-06012	Pin,axle 销B6×12	1	GB882-86
16	B0330-10020	Bolt 螺栓M10×20	2	GB5783-86
17	B5050-00010	Washer,lock 垫圈10	2	GB93-87
18	H25S5-60501	Soft shaft 油门拉索	1	
19	B3220-05012	Pin,axle 销B5×12	1	GB882-86
20	H2B95-62011	Bracket 油门支架	1	
21	Z2131-01015	Bushing 钢背轴承1015	1	

CPCD20,25,30-Ku1

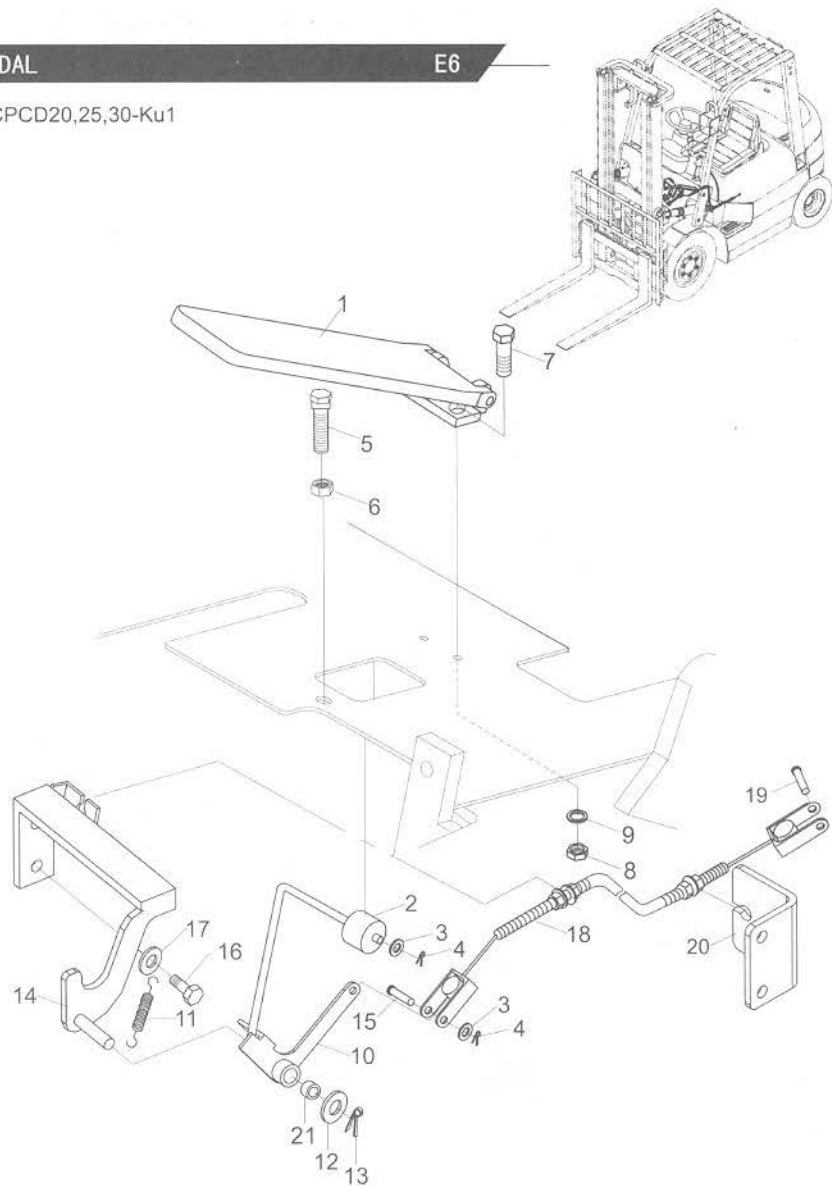

CPC20,25,30-Ku1

序号 Item No	图号 Part No	零部件名称 Description	件数 Q'ty	备注 Remark
A	H2A95-60001	Accelerator pedal 油门操纵装置	1	
01	H24C5-60201	Accelerator pedal ass'y 踏板总成	1	
02	H24C5-62021	Sheave 滚轮	1	
03	B5310-00006	Washer 垫圈6	2	GB97.1-85
04	B3010-02020	Pin 销2×20	2	GB91-86
05	25785-22111	Bolt 螺栓	1	
06	B4216-00012	Nut 螺母M12×1.25	1	GB6171-86
07	B0330-06020	Bolt 螺栓M6×20	2	GB5783-86
08	B4116-00006	Nut 螺母M6	2	GB6170-86
09	B5050-00006	Washer,lock 垫圈6	2	GB93-87
10	H24C5-60611	Bracket 连接轴架	1	
11	25785-22031	Spring 弹簧	1	
12	B5310-00010	Washer 垫圈10	1	GB971-85
13	B3010-3P220	Pin 销3.2×20	1	GB91-86
14	H24C5-60701	Bracket 支架	1	
15	B3220-06012	Pin,axle 销B6×12	1	GB882-86
16	B0330-10020	Bolt 螺栓M10×20	2	GB5783-86
17	B5050-00010	Washer,lock 垫圈10	2	GB93-87
18	H25S5-60501	Soft shaft 油门拉索	1	
19	B3220-05012	Pin,axle 销B5×12	1	GB882-86
20	H2B95-62011	Bracket 油门支架	1	
21	Z2131-01015	Bushing 钢背轴承1015	1	



图95/FIG95

行车制动与微动操纵(液力式)/BRAKE & INCHING CONTROL (TOR-CON TYPE)

E8

序号 Item No	图号 Part No	零部件名称 Description	件数 Q'ty	备注 Remark
A	H25S5-40001	Inching & Brake pedal ass'y 行车制动与微动操纵装置	1	CPCD20,25
-	H24S5-40001	Inching & Brake pedal ass'y 行车制动与微动操纵装置	1	CPQD20,25
-	H25T5-40001	Inching & Brake pedal ass'y 行车制动与微动操纵装置	1	CPQD30,35 CPCD30,35
01	Z3775-42102	Tank, reserve 制动液储油罐	1	
02	B0330-08020	Bolt 螺栓M8X20	2	GB5783-86
03	B5310-00008	Washer 垫圈8	6	GB97.1-85
04	B5050-00008	Washer, lock 垫圈8	2	GB93-87
05	H24C5-31901	Clip 储油罐夹	1	
06	Z7302-10110	Hose 胶管 $\varnothing 9.5$ L=1100	1	
07	Z4590-00016	Clip 双钢丝卡箍 $\varnothing 16$	2	
08	H25S5-40202	Hose 油管总成(右)	1	CPCD20,25 CPQD20,25
-	H25T5-40201	Hose 制动油管(右)	1	CPQD30,35 CPCD30,35
09	Z4455-42211	Clip 管夹	1	
10	Z2505-42121G	Hose 油管总成	1	CPCD20,25 CPQD20,25
-	H25T5-40301	Hose 制动油管(左)	1	CPQD30,35 CPCD30,35
11	H24C5-32041	Clip 管夹	1	
12	Z4245-42201	Clip 管夹	1	
13	Z4245-42301	Clip 管夹	1	
14	H25S5-40401	Inching pedal 微动踏板	1	
15	H25S5-40501	Brake pedal 制动踏板	1	
16	B0330-10025	Bolt 螺栓M10X25	2	GB5783-86
17	B5050-00010	Washer, lock 垫圈10	2	GB93-87
18	B3230-08030	Pin, clevis 销B8X30	4	GB882-86
19	B3010-2P516	Pin 销2.5X16	5	GB91-86
20	Z3235-40091	Rubber 橡皮顶轴	1	
21	Z2505-42001	Link 连接杆	1	
22	B5310-00016	Washer 垫圈16	1	GB97.1-85
23	B3010-04026	Pin 销4X26	1	GB91-86
24	Z2135-01625	Bushing 钢背轴承1625	1	
25	B0330-10020	Bolt 螺栓M10X20	2	GB5783-86

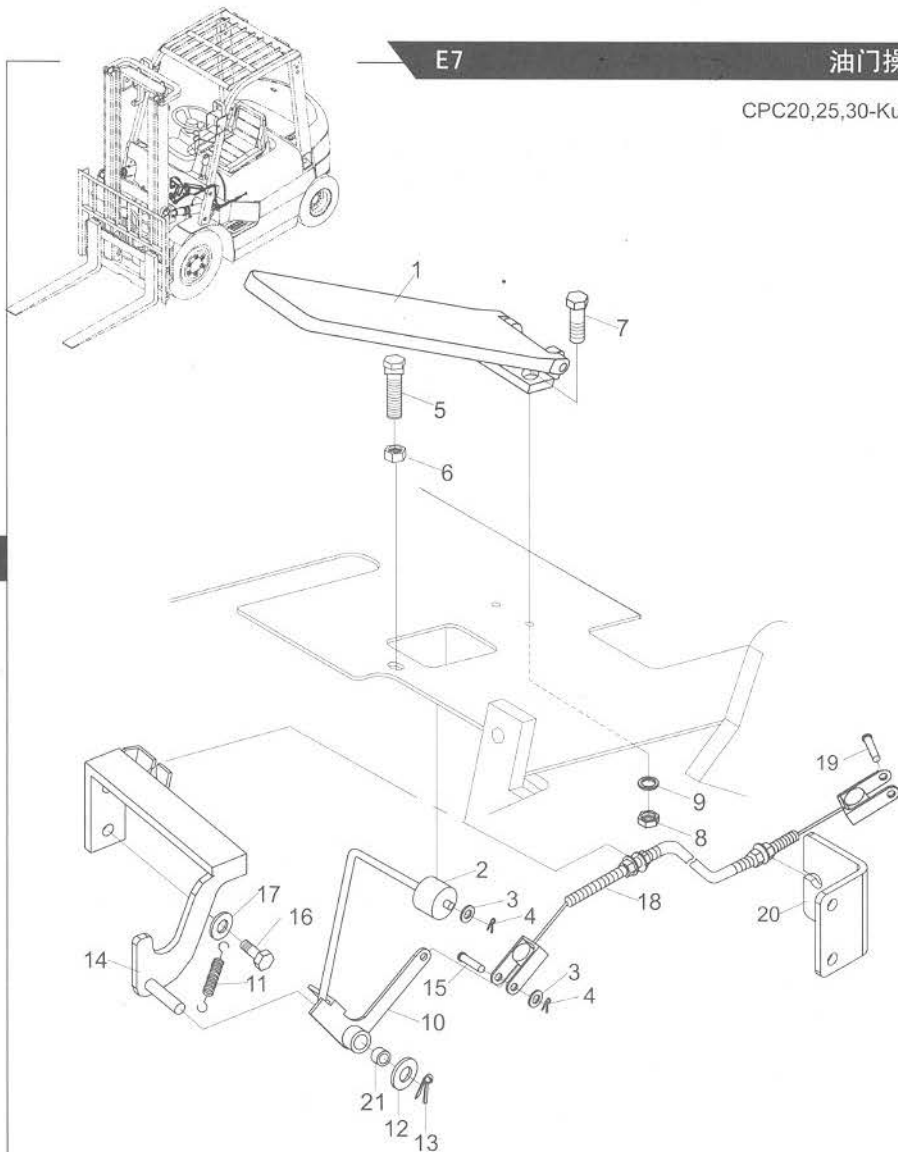
CPCD,CPQD20,25,30,35

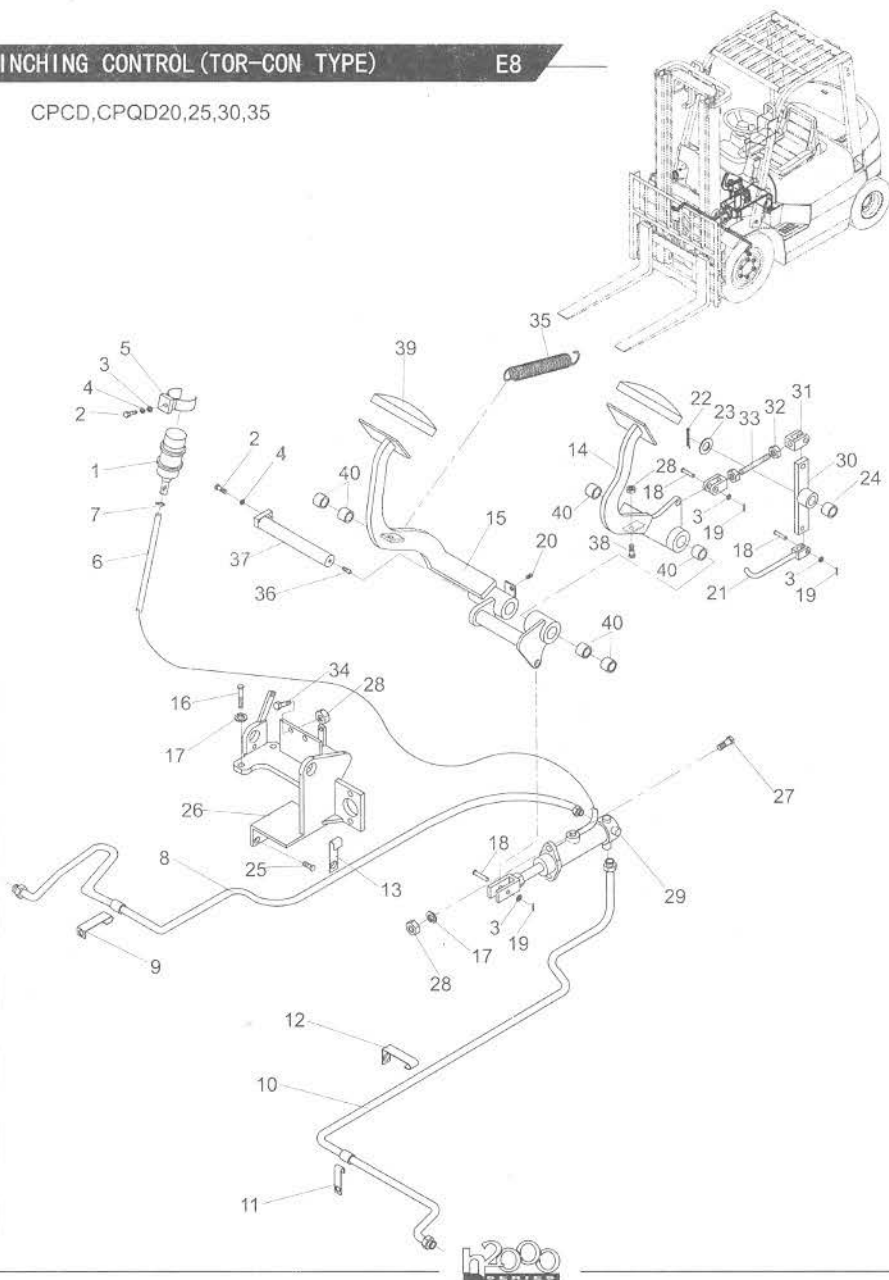

E

h2000

CPCD,CPQD20,25,30,35

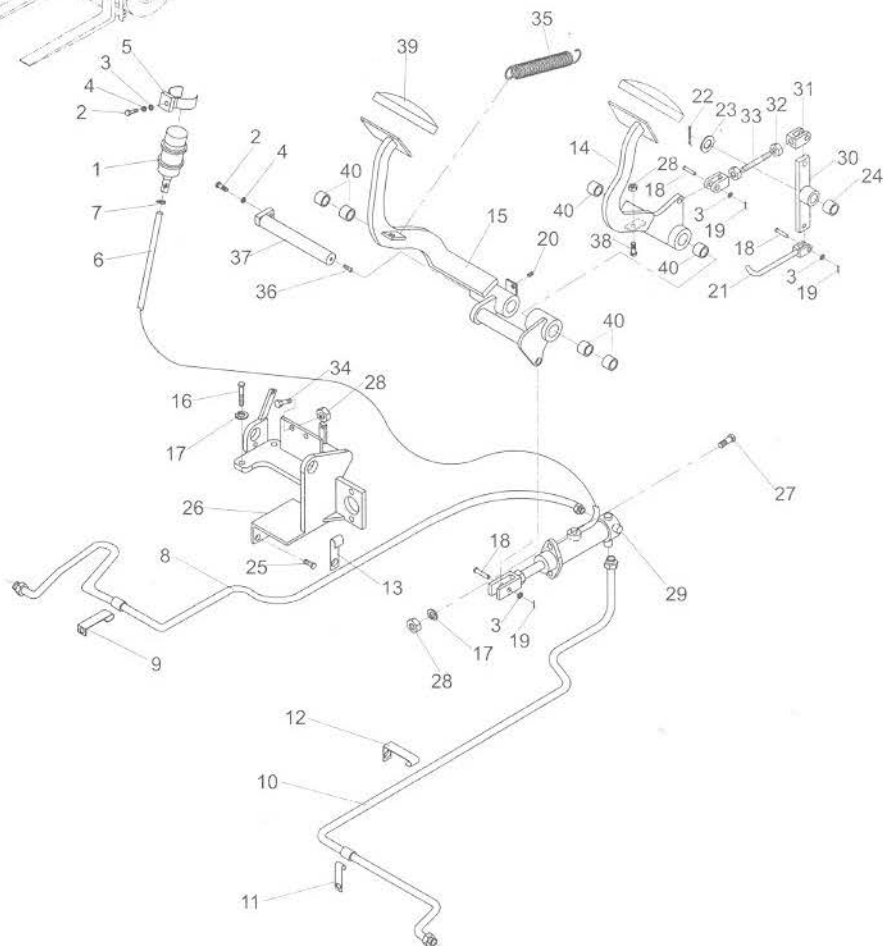
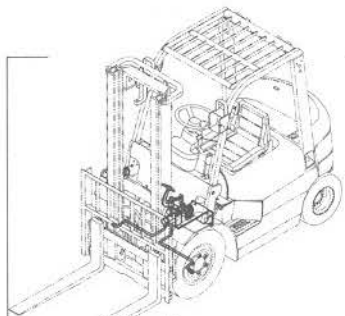

序号 Item No	图号 Part No	零部件名称 Description	件数 Q'ty	备注 Remark	
26	H24S5-40601	Bracket	支架	1	
27	B0330-10035	Bolt	螺栓M10×35	2	GB5783-86
28	B4116-00010	Nut	螺母M10	4	GB6170-86
29	25595-40302	Master cylinder	制动总泵	1	See Fig.98
30	H25S5-40701	Link	摇臂	1	
31	H25S5-42221	Clevis	支耳M10-6H(左旋)	1	
-	H25S5-42211	Clevis	支耳M10-6H(右旋)	1	
32	B4123-10010	Nut	螺母M10(左)	1	GB6170-86
33	23745-42031	Rod	螺杆	1	
34	B0330-10030	Bolt	螺栓M10×30	1	GB5783-86
35	20155-30061	Spring	拉簧	2	
36	Z2513-01010	Fitting	油杯90M10×1	1	GB1153-74
37	25595-42182	Shaft	油轴	1	
38	B0330-10040	Bolt	螺栓M10×40	1	GB5783-86
39	25595-42071	Head cover	踏板垫	2	
40	Z2135-02525	Bushing	钢背轴承2525	6	

图96/FIG96

行车制动与离合操纵(机械式)/BRAKE & CLUTCH CONTROL (CLUTCH TYPE)

E9

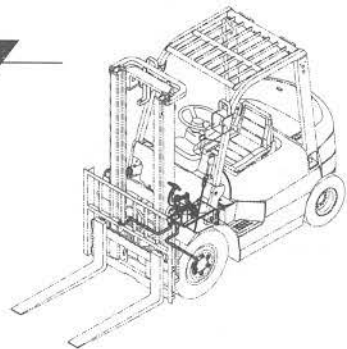

序号 Item No	图号 Part No	零部件名称 Description	件数 Q'ty	备注 Remark
A	H24C5-30001	Clutch&Breake pedal ass'y	1	CPC20,25 CPQ20,25
-	H24N5-30001	Clutch&Breake pedal ass'y	1	CPC30,35 CPQ30,35
01	B0330-08020	Bolt	2	GB5783-86
02	B5310-00008	Washer	4	GB97.1-85
03	B5050-00008	Washer, lock	2	GB93-87
04	H24C5-31901	Clip	1	储油罐夹
05	H24C5-30301	Tank, reserve	1	制动液储油罐
06	Z2131-02525	Bushing	2	钢背轴承2525
07	Z4590-00016	Clip	4	双钢丝卡箍∅16
08	Z7302-10050	Hose	2	制动油管∅9.5 L=500 GB/T7127.1-2000
09	25595-40302	Master cylinder	1	制动总泵 See Fig.98
10	H24C5-30401	Master cylinder	1	离合总泵
11	H24C5-30501	Hose	1	离合油管
12	24455-42211	Clip	1	管夹
13	H24C5-30601	Hose(right)	1	制动油管(右) CPC20,25 CPQ20,25
-	H24N5-30201	Hose(right)	1	制动油管(右) CPC30,35 CPQ30,35
14	H24C5-32041	Clip	1	管夹
15	H24C5-30701	Hose(left)	1	制动油管(左) CPC20,25 CPQ20,25
-	H24N5-30301	Hose(left)	1	制动油管(左) CPC30,35 CPQ30,35
16	H24C5-30801	Clutch pedal (Inc.23)	1	离合踏板
17	B0330-10035	Bolt	4	螺栓M10X35 GB5783-86
18	B4116-00010	Nut	8	螺母M10 GB6170-86
19	B5050-00010	Washer,lock	6	垫圈10 GB93-87
20	B0330-10035	Bolt	2	螺栓M10X35 GB5783-86
21	B3220-10026	Pin, clevis	3	销B10X26 GB882-86
22	B3010-2P516	Pin, snap	3	销2.5X16 GB91-86
23	Z2132-02525	Bushing	2	钢背轴承2525
24	23235-40091	Rubber	1	橡皮顶轴
25	H24C5-30901	Pin, clevis	1	销轴
26	H24C5-31001	Brake pedal (Inc.6)	1	制动踏板

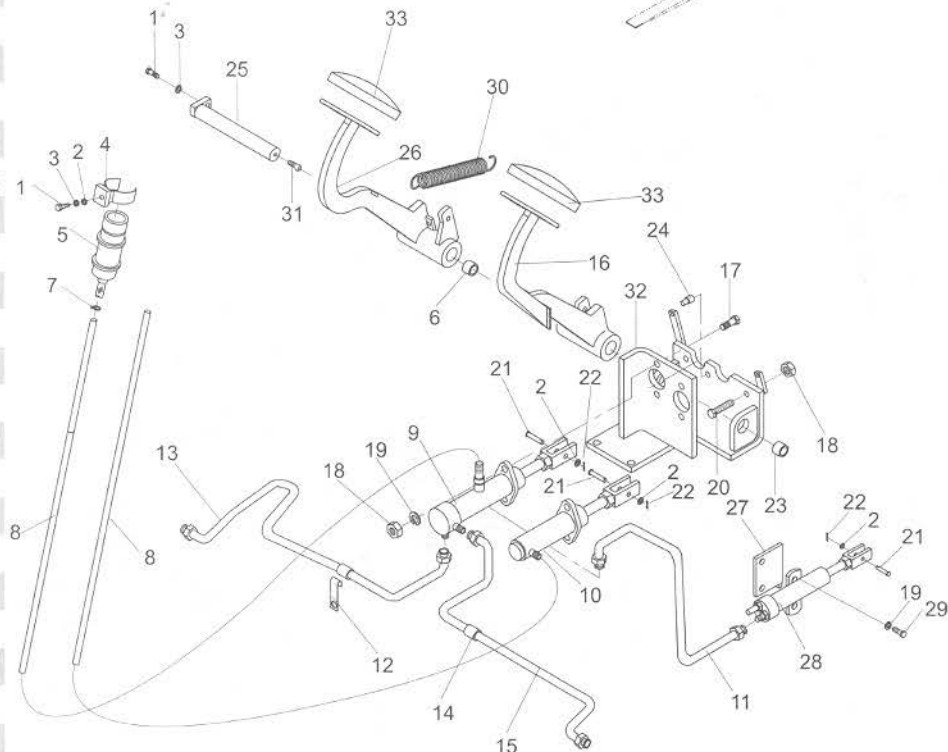

CPQ20,25,30,35
CPC20,25,30-W7,W8
CPC20,25,30-W9,Xs1,HJ
CPC35-W4,W5,W6,Xs1,HJ

CPQ20,25,30,35
CPC20,25,30-W7,W8
CPC20,25,30-W9,Xs1,HJ
CPC35-W4,W5,W6,Xs1,HJ

序号 Item No	图号 Part No	零部件名称 Description	件数 Qty	备注 Remark
27	H24C5-31101	Bracket	支承架	1
28	H24C5-31201	Release cylinder	离合助力泵	1
29	B0330-10030	Bolt	螺栓 M10 X30	2 GB5783-86
30	20155-30061	Spring	拉簧	2
31	Z2513-01010	Fitting	油杯90M10X1	1 GB1153-74
32	H24C5-31301	Bracket	支架	1
33	25595-42071	Head cover	踏板垫	2



图97/FIG97

行车制动与离合操纵/BRAKE & CLUTCH CONTROL

E10

序号 Item No	图号 Part No	零部件名称 Description	件数 Q'ty	备注 Remark
A	HRH93C5301	Clutch&Breake pedal ass'y	1	2t,2.5t
-	H93C5-30001	Clutch&Breake pedal ass'y	1	3t,3.5t
1	B0330-08020	Bolt	2	GB5783-86
2	B5310-00008	Washer	2	GB97.1-85
3	B5050-00008	Washer,lock	2	GB93-87
4	H24C5-31901	Clip	1	储油罐夹
5	23775-42102	Tank,reserve	1	储油罐
6	Z4590-00016	Clip	4	双钢丝卡箍 \varnothing 16
7	Z7302-10050	Hose	1	胶管 \varnothing 9.5 L=500
8	25595-40302	Master cylinder	1	制动总泵 See Fig. 98
9	H24C5-30601	Hose(right)	1	制动油管(右) 2t,2.5t
-	H24N5-30201	Hose(right)	1	制动油管(右) 3t,3.5t
10	24455-42211	Clip	1	管夹
11	H24C5-30701	Hose(left)	1	制动油管(左) 2t,2.5t
-	H24N5-30301	Hose(left)	1	制动油管(左) 3t,3.5t
12	H24C5-32041	Clip	1	管夹
13	H93C5-30211	Clutch pedal	1	离合踏板
14	B3010-2P530	Snap pin	1	销2.5X30 GB91-86
15	B5310-00010	Washer	1	垫圈10 GB97.1-85
16	H93C5-32041	Rod	1	分离杆
17	23655-32521	Washer	1	垫圈
18	23655-32512	Spring	1	压簧
19	22215-30042	Nut	1	螺母
20	B4123-00012	Nut	1	螺母M12 GB6170-86
21	23235-40091	Rubber	1	橡皮顶轴
22	H24C5-30901	Pin,clevis	1	销轴
23	H24C5-31001	Brake pedal(包含35)	1	制动踏板
24	20155-30061	Spring	2	拉簧
25	Z2513-01010	Fitting	1	油杯90° M10X1
26	H93C5-30201	Bracket	1	支架

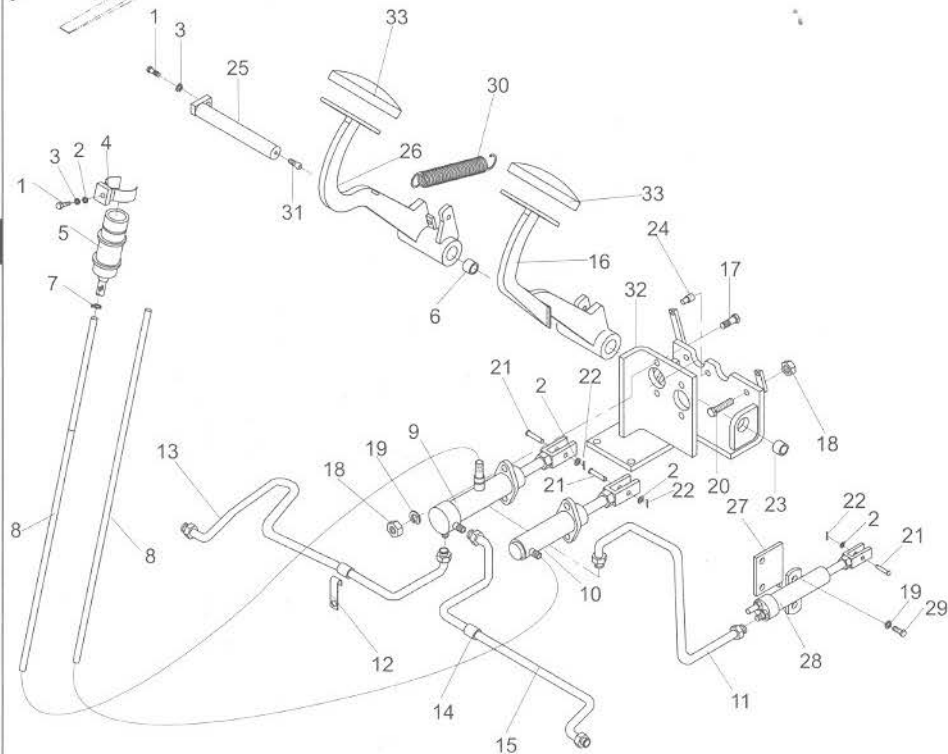
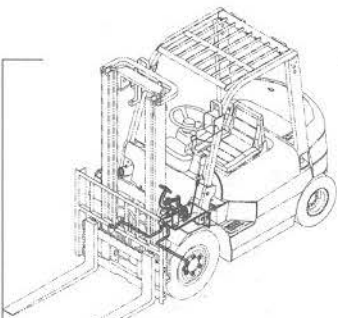
CPC20,25,30-X6,S2,D,Ku1
CPC35-X2,S1,D
CPQ20,25,30,35-ZJ2,ZJ3

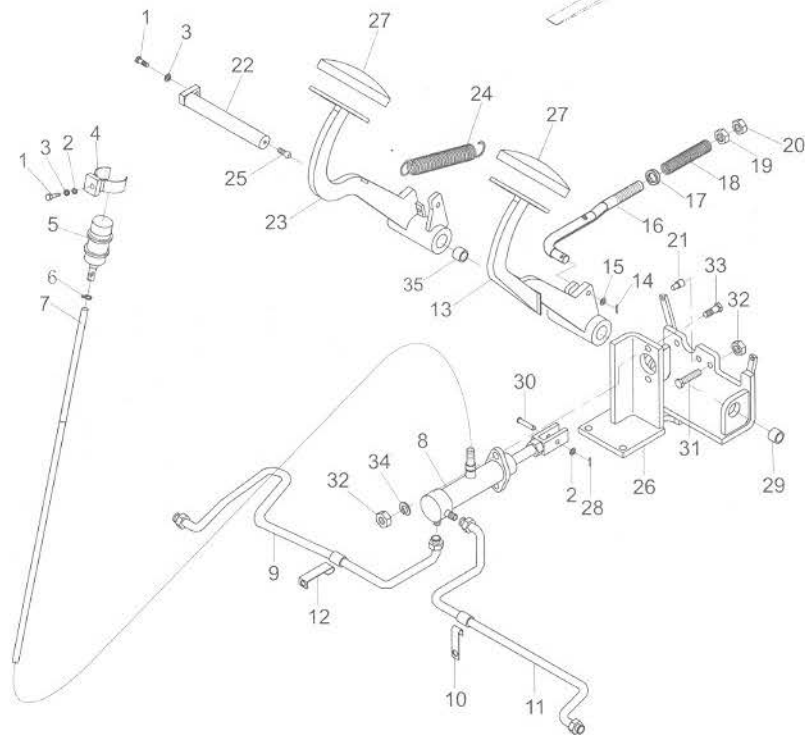

CPC20,25,30-X6,S2,D,Ku1
CPC35-X2,S1,D
CPQ20,25,30,35-ZJ2,ZJ3

序号 Item No	图号 Part No	零部件名称 Description	件数 Q'ty	备注 Remark	
27	25595-42071	Head cover	踏板垫	2	
28	B3010-2P516	Pin,snap	销 2.5X16	1	GB91-86
29	Z2132-02525	Bushing	钢背轴承2525	2	
30	B3220-10026	Pin,clevis	销B10X26	1	GB882-86
31	B0330-10030	Bolt	螺栓M10X30	2	GB5783-86
32	B4116-00010	Nut	螺母M10	4	GB6170-86
33	B0330-10035	Bolt	螺栓M10X35	2	GB5783-86
34	B5050-00010	Washer,lock	垫圈10	2	GB93-87
35	Z2131-02525	Bushing	钢背轴承2525	2	



图98/FIG98

制动总泵/MASTER CYLINDER

E11

序号 Item No	图号 Part No	零部件名称 Description	件数 Q'ty	备注 Remark
A	25595-40302	Master cylinder	制动总泵	1
01	25595-42301	Body	阀体	1
02	25595-42311	Ring, stopper	止动环	1
03	25595-42332	Piston	活塞	1
B	25595-40402	Cup groupware (Inc.04-06)	皮碗组件	1
04	25595-42322	Cup, secondary	前皮碗	1
05	25595-42341	Spacer, cup	衬套皮碗	1
06	25595-42351	Cup, primary	主皮碗	1
07	25595-42361	Sear, spring	弹簧座	1
08	25595-42371	Spring	弹簧	1
09	25595-42381	Valve, check	切断阀	1
10	25595-42391	Seat, valve	阀座	1
11	25595-42431	Boots	保护罩	1
12	25595-42441	Rod, push	推杆	1
13	25595-42451	Clevis	支耳	1
14	B5050-00008	Nut	螺母M8	1 GB6170-86
15	25595-42421	Bushing, rubber	胶皮衬套	1
16	25595-42411	Union	接头	1

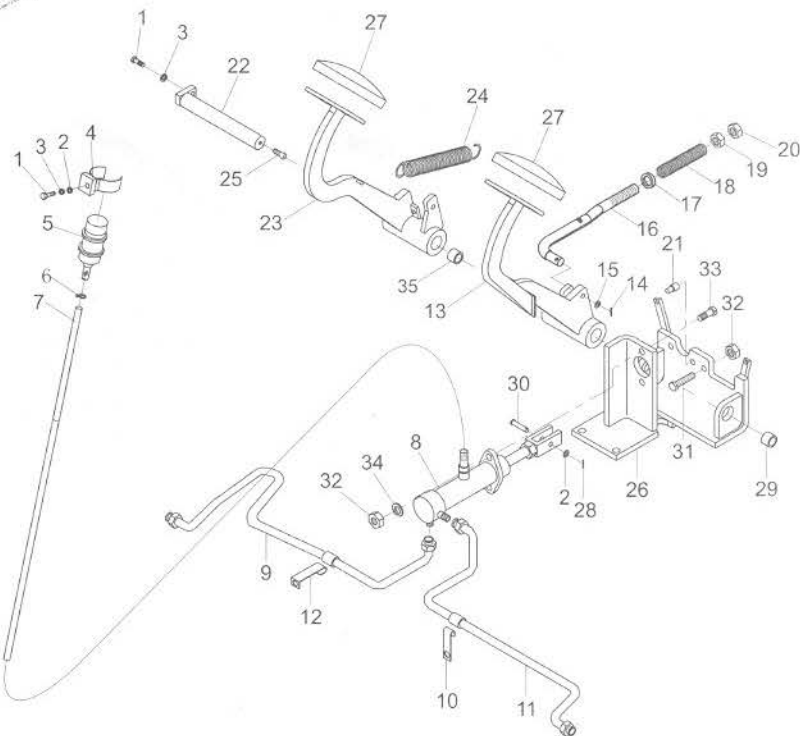
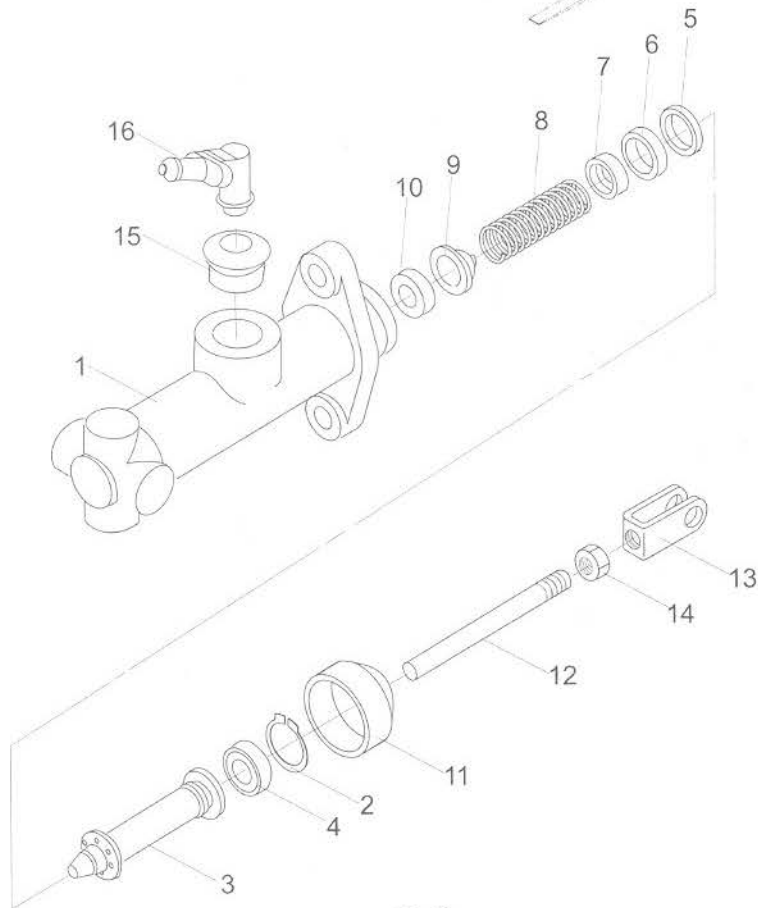
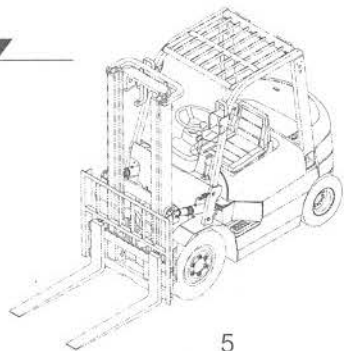
CPC, CPCD20, 25, 30, 35
CPQ, CPQD20, 25, 30, 35

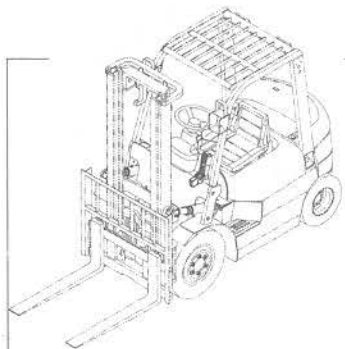

CPC, CPCD20, 25, 30, 35
CPQ, CPQD20, 25, 30, 35

序号
Item
No

图号
Part No

零部件名称
Description

件数
Q'ty

备注
Remark

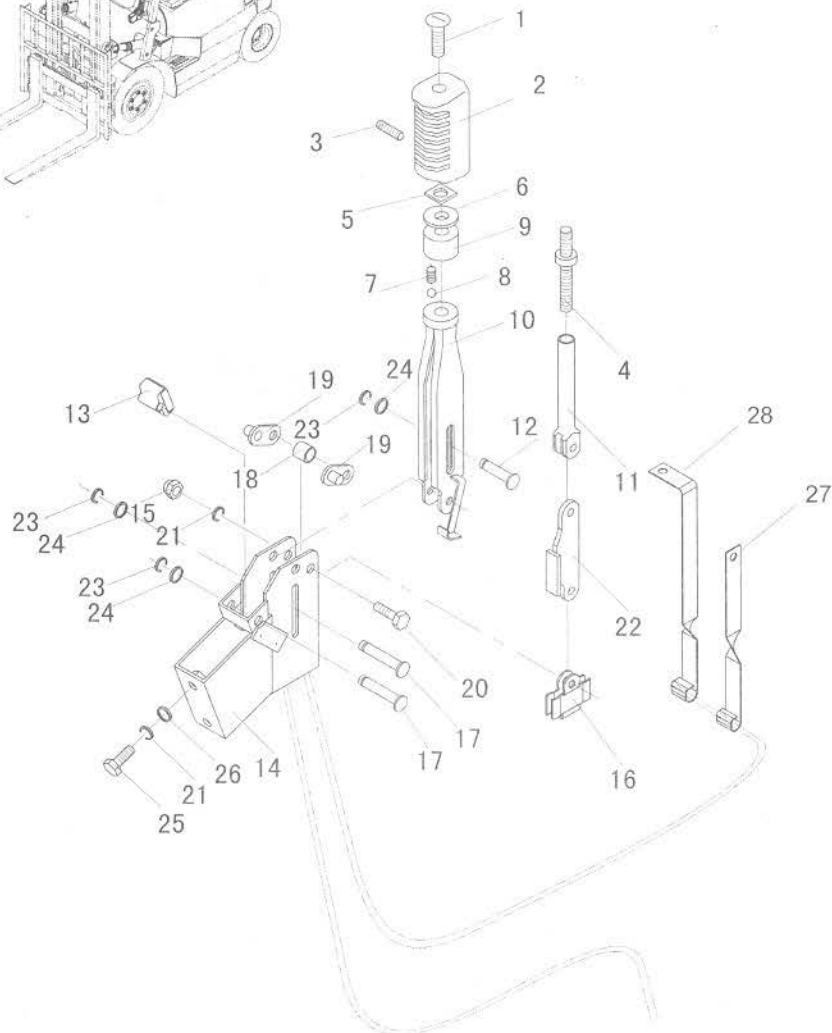

序号 Item No	图号 Part No	零部件名称 Description	件数 Q'ty	备注 Remark
A	REF105325G	Brake lever	1	停车制动装置
01	THN-111	Over head	1	调节杆
02	THN-110	Grip	1	手柄头
03	B1830-04004	Screw	1	内六角凹端紧定螺钉M4X3.7 GB80-85
04	THN-500	Screw rod	1	螺杆
05	B7810-00008	Nut	1	方螺母M8 GB39-88
06	B5210-00008	Washer	1	大垫圈 GB96-85
07	THN-200	Spring	1	弹簧1X5.5X10.8
08	GB308-64	Ball	1	钢球Ø6
09	THN-101	Seat	1	手柄座
10	THN-060	Lever	1	闸把体
11	THN-600	Rod	1	拉杆体
12	B3220-08035	Pin	1	平头销B8X35 GB882-86
13	THN-098A	Stopper	1	限位块
14	THN-050	Bracket	1	支架总成
15	B7910-00010	Nut	1	组合式盖形螺母M10 GB923-88
16	21235-52171G	Bracket	1	挂线架
17	B3220-08045	Pin	1	平头销B8X45 GB882-86
18	25785-52261	Washer	1	垫圈II
19	THN-40-00	Plate	2	支撑板总成
20	B0220-10045	Bolt	1	螺栓M10X45 GB5782-86
21	B5050-00010	Washer,lock	3	垫圈10 GB93-87
22	THN-900-00	Link	1	拉板总成
23	B6250-00008	Washer	3	垫圈8 GB896-86
24	B5310-00008	Washer	6	垫圈8 GB97.1-85
25	B0220-10040	Bolt	2	螺栓M10X40 GB5782-86
26	B5310-00010	Washer	2	垫圈10 GB97.1-85
27	22495-55611	Pothook	1	手制动管托 CPCD, CPQD
28	22495-55621G	Pothook	1	机械车拉索吊钩 CPC, CPQ

图100/FIG100

车架与平衡重/FRAME & COUNTER WEIGHT

F1

序号 Item No	图号 Part No	零部件名称 Description	件数 Qty	备注 Remark
01	HRH24C6121 H24C6-10004	Frame	车架 1	CPC(D)20,25-R6 CPQ(D)20H,25H-R11
-	HRH24N6101 H24N6-10001	Frame	车架 1	CPC(D)30-R6,R12 CPQ(D)35-R3,R4
-	HRH24N6101 H25T6-10001	Frame	车架 1	CPC(D)30-W8 CPC(D)35-W4
-	HRH24C6121 H25S6-10004	Frame	车架 1	CPC,CPCD20,25- W7,W9
-	HRH24N6101 H27N6-10001	Frame	车架 1	CPC,CPCD30-W7,W9 CPC(D)35-W5,W6
-	H99U6-10001	Frame	车架 1	CPC(D)20,25-Ku1
-	H99Y6-10001	Frame	车架 1	CPC(D)30-Ku1
-	H27C6-10001	Frame	车架 1	CPC(D)20,25-WS
-	H9A16-10001	Frame	车架 1	CPC(D)20,25-X6
-	H9E16-10001	Frame	车架 1	CPC(D)30-X6 CPC(D)35-X2
-	H2B16-10001	Frame	车架 1	CPC(D)20,25-Xs1
-	H2F16-10001	Frame	车架 1	CPC(D)30,35-Xs1
-	HRH24C6121 H97U6-10001	Frame	车架 1	CPC(D)20,25-HJ
-	HRH24N6101 H97Y6-10001	Frame	车架 1	CPC(D)30,35-HJ
-	H99U6-10001	Frame	车架 1	CPC(D)20,25-D
-	H99Y6-10001	Frame	车架 1	CPC(D)30,35-D
-	H94C6-10001	Frame	车架 1	CPQ(D)20,25-ZJ2
-	H94N6-10001	Frame	车架 1	CPQ(D)30,35-ZJ2
-	H96C6-10001	Frame	车架 1	CPQ(D)20,25-ZJ3
-	H96N6-10001	Frame	车架 1	CPQ(D)30,35-ZJ3
02	B0230-30120	Bolt	螺栓M30X120	1 2t GB5782-86
-	B0230-30180	Bolt	螺栓M30X180	1 2.5t,3t,3.5t GB5782-86
03	B5050-00030	Washer,lock	垫圈30	1 GB93-87
04	22216-30051	Washer	平垫圈	1
05	H24C6-32003	Counter weight	平衡重体	1 2t
-	H25S6-32003	Counter weight	平衡重体	1 2.5t
-	H24N6-32001	Counter weight	平衡重体	1 3t
-	H05A6-32001	Counter weight	平衡重体	1 3.5t
06	A24K6-32011	Cap	平衡重饰盖	2
07	25596-32051	Pin	牵引销	1

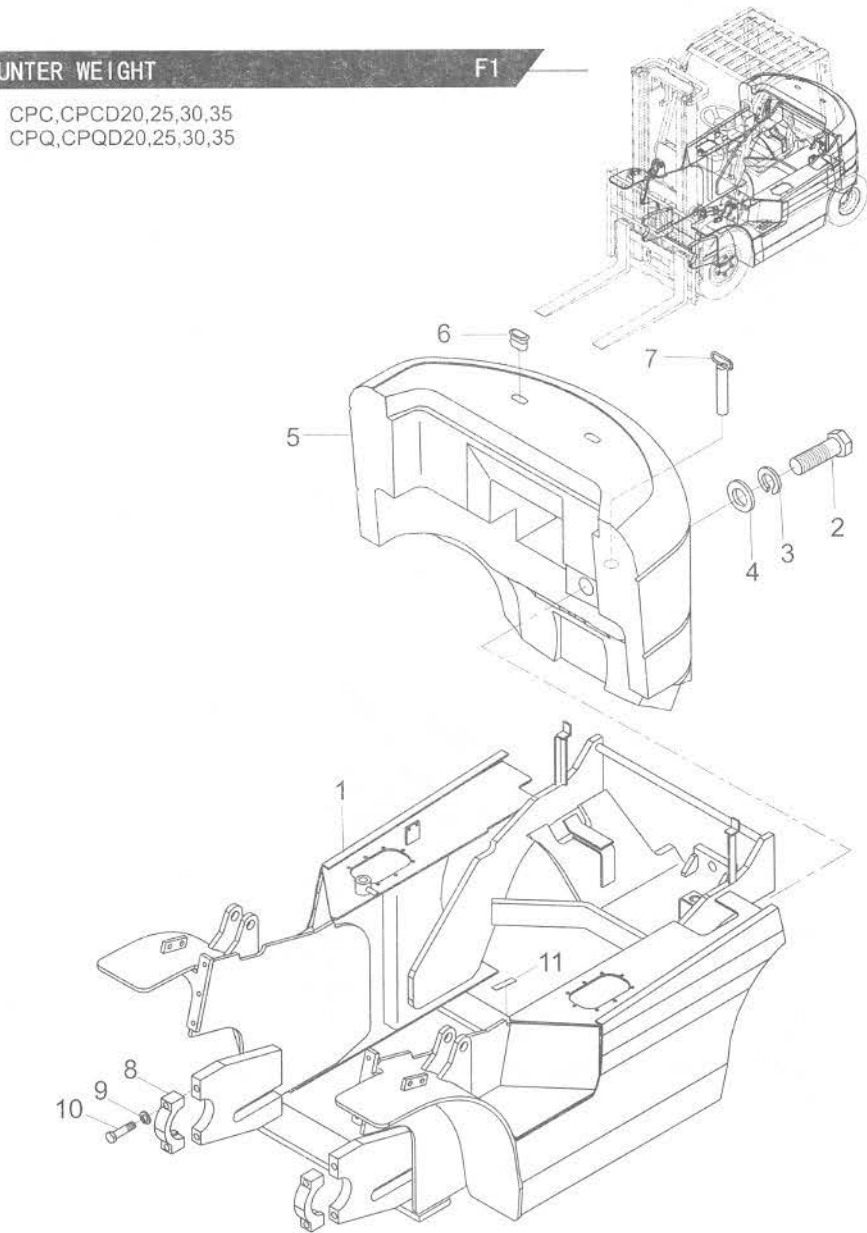

F1

车架与平衡重/FRAME & COUNTER WEIGHT

图100/FIG100

CPC,CPCD20,25,30,35
CPQ,CPQD20,25,30,35

序号 Item No	图号 Part No	零部件名称 Description	件数 Q'ty	备注 Remark
08	22018-30064	Cap,front axle support	支座盖 2	
09	B5050-00016	Washer,lock	垫圈16 4	GB93-87
10	B0430-16070	Bolt	螺栓M16X1.5X70 4	GB5785-86
11	H24C6-42951	Rubber	橡胶条(2X20X100) 2	



图101/FIG101

机罩、底板及座椅/HOOD, FLOOR BOARD & SEAT

F2

序号 Item No	图号 Part No	零部件名称 Description	件数 Q'ty	备注 Remark
01	B5310-00008	Washer	垫圈8	14 GB97.1-85
02	B6250-00006	Snap ring	挡圈6	2 GB896-86
03	B4116-00010	Nut	螺母M10	4 GB6170-86
04	B0530-10020	Bolt	螺栓M10X1.25X20	7 GB5786-86
05	B5050-00010	Washer,lock	垫圈10	11 GB93-87
06	H93C6-40201	Cabinet	仪表架	1 2t.2.5t
-	H05A6-40201	Cabinet	仪表架	1 3.5t
07	H24C6-42311	Rubber	橡胶垫	4
08	B0230-10040	Bolt	螺栓M10X40	4 GB5782-86
09	B5210-00010	Washer	垫圈10	4 GB96-85
10	H24C6-42321	Pipe	衬管 \varnothing 13X1.2 L=19	4
11	H24C6-40322	Bracket	转向支架	1
12	H24C6-40403	Bonnet	内燃机罩	1
13	P3220	Shock,absorber	气弹簧	1
14	B4413-00008	Nut	螺母M8X1	2 GB6173-86
15	B0330-08016	Bolt	螺栓M8X16	16 GB5783-86
16	B5050-00008	Washer,lock	垫圈8	14 GB93-87
17	H24C6-80001	Seat	座椅	1
18	HRH24C6512 H25S6-50102	Floor board	后底板总成	1 除CPCD20~35-D CPQD20~35-ZJ3
-	HRH24C6512 H24C6-50102	Floor board	后底板总成	1 CPC20~35-D CPQ20~35-ZJ3
-	HRH99Y6502 H99Z6-50201	Floor board	后底板总成	1 CPCD20~35-D CPQD20~35-ZJ3
-	HRH99Y6502 H99Y6-50201	Floor board	后底板总成	1 CPC20~35-D CPQ20~35-ZJ3
19	A22A6-42511	Screw	螺钉	2
20	H24C6-42032	Cover	水箱盖板	1
21	HRH24C6402 H24C6-42041	Gasket L.H.	垫(左)	1
22	HRH24C6402 H24C6-42051	Gasket R.H.	垫(右)	1
23	HRH24C6513 H25S6-50302	Floor board	前底板总成	1 CPCD、CPQD
-	HRH24C6513 H24C6-50302	Floor board	前底板总成	1 CPC、CPQ
24	Z7500-051P3	Pipe	套管 \varnothing 5X2X13	4
25	HRH24C6518 H24C6-52552	Gasket	密封垫(左)	1

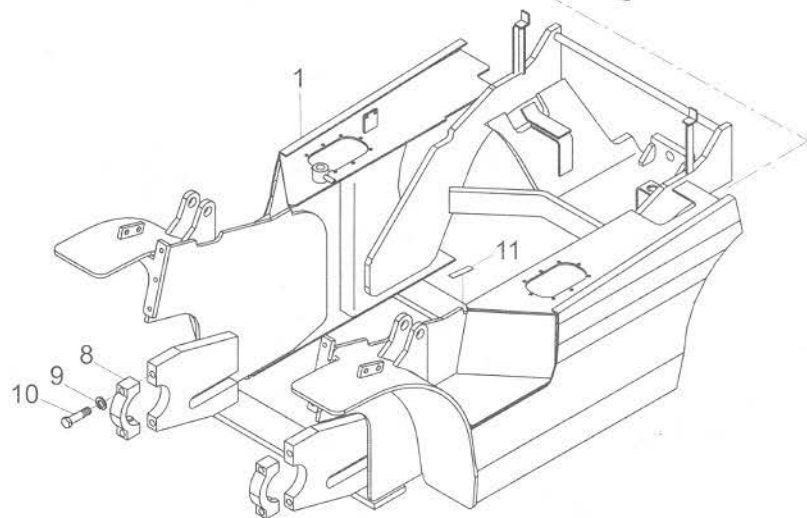
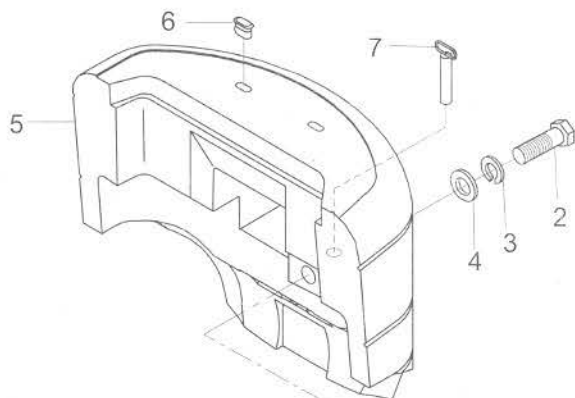
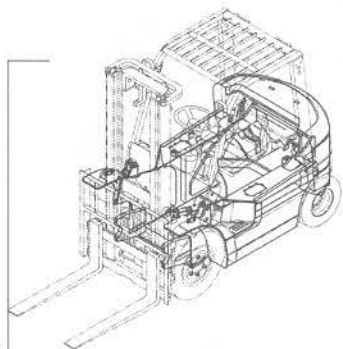
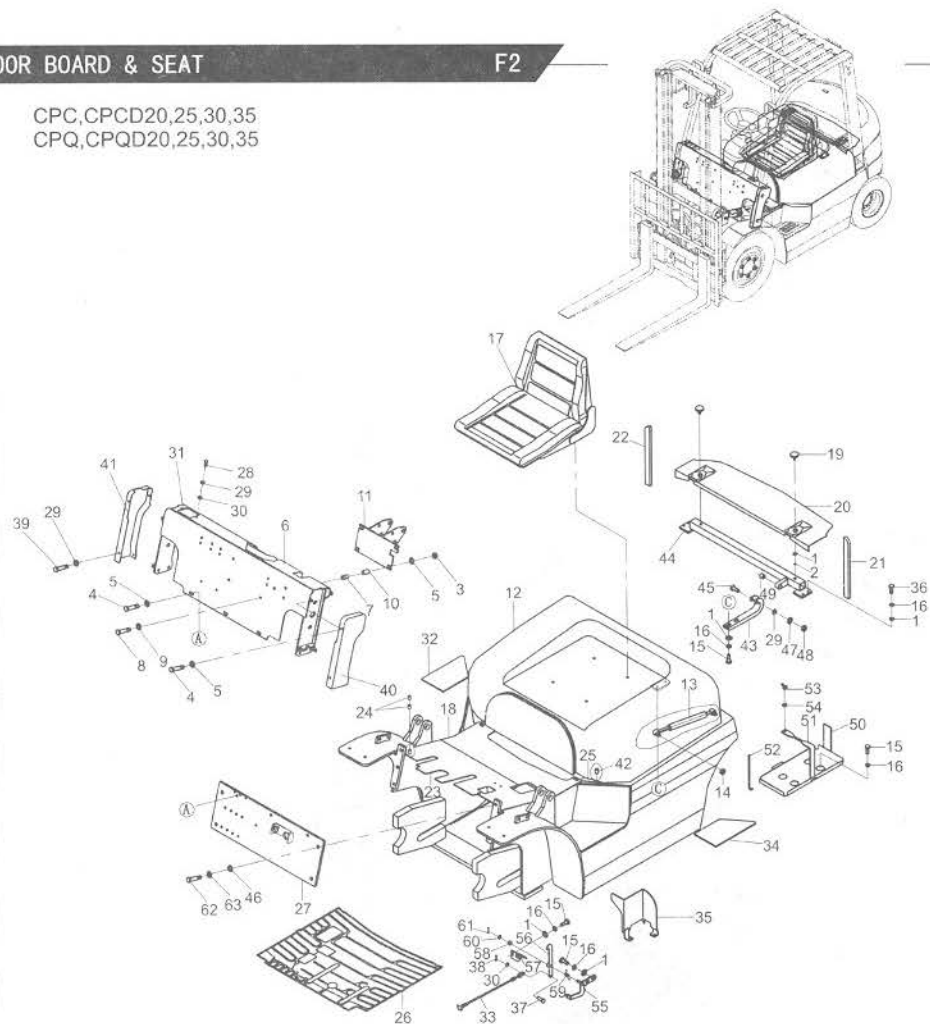

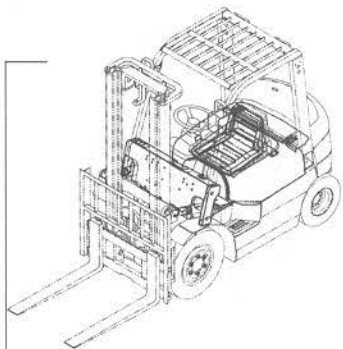

F2

机罩、底板及座椅/HOOD, FLOOR BOARD & SEAT

图101/FIG101

CPC, CPCD20, 25, 30, 35
CPQ, CPQD20, 25, 30, 35

序号 Item No	图号 Part No	零部件名称 Description	件数 Q'ty	备注 Remark
-	HRH24C6518 H24C6-52562	Gasket	1	密封垫(右)
26	HRH24C6514 H25S6-52012	Gasket	1	底板垫
-	HRH24C6514 H24C6-52012	Gasket	1	底板垫
-	HRH99Y6506 H99Z6-50601	Gasket	1	底板垫
-	HRH99Y6506 H99Y6-50601	Gasket	1	底板垫
27	H24C6-40902	Plate	1	前板总成
28	B1210-06016	Screw	2	螺钉M6X16
29	B5050-00006	Washer, lock	4	垫圈6
30	B5310-00006	Washer	3	垫圈6
31	H24C6-42072	Box	1	工具箱
32	HRH24C6416 H24C6-43223	Treadboard R.H.	1	橡胶垫(右)
33	A24K6-40901	Cable	1	拉索总成
34	HRH24C6416 H24C6-43123	Treadboard L.H.	1	橡胶垫(左)
35	H24C6-41303	Panel	1	电气板总成
-	H25S6-41303	Panel	1	电气板总成
-	H93C6-40302	Panel	1	电气板总成
-	H97Y6-42001	Panel	1	电气板总成
-	H2B16-41201	Panel	1	电气板总成
36	B0330-10025	Bolt	4	螺栓M10X25
37	B3220-06016	Pin clevis	1	销B6X16
38	B3010-02010	Pin	1	销2X10
39	B1410-06012	Screw	4	螺钉M6X12
40	HRA73J6402 A73J6-42052	Cap	1	护罩(左)
41	HRA73J6402 A73J6-42062	Cap	1	护罩(右)
42	Z7400-08002	Pipe	2	套管∅8X1X20
43	H24C6-42511	Hinge	2	铰链
44	H24C6-40512	Bracket	1	支架
45	A24K6-42411	Bolt	2	螺栓
46	B5310-00016	Washer	6	垫圈16

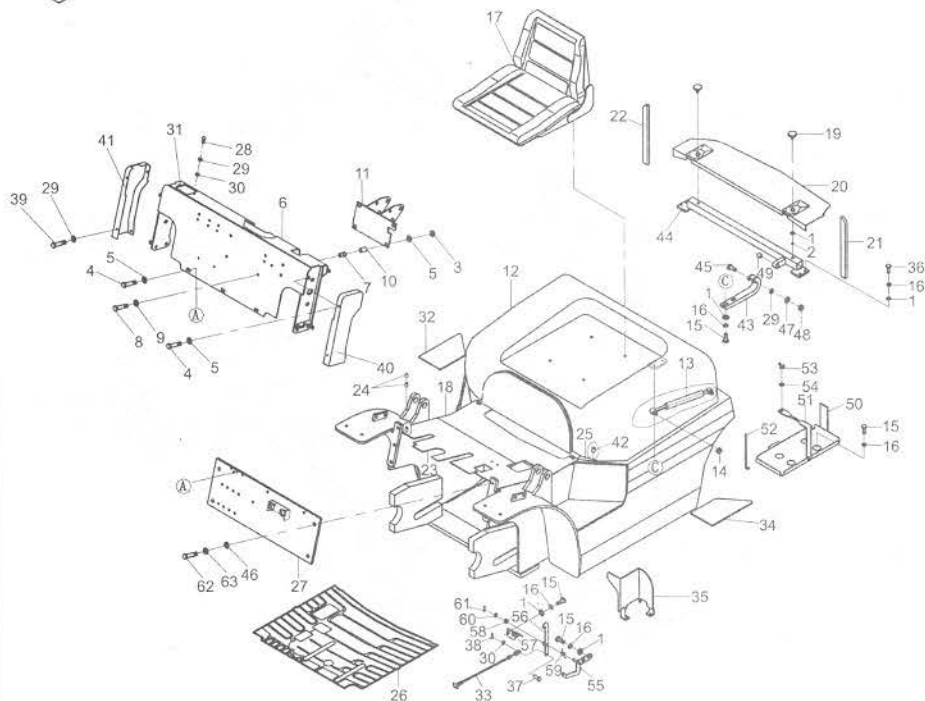

F

图101/FIG101

机罩、底板及座椅/HOOD, FLOOR BOARD & SEAT

F2

序号 Item No	图号 Part No	零部件名称 Description	件数 Q'ty	备注 Remark
47	B5310-00006	Washer	垫圈6	2 GB97.1-85
48	B4313-00006	Nut	螺母M6	2 GB6172-86
49	A24K6-42421	Bushing	衬套	2
50	HRH24C6404 H24C6-40612	Bracket	电瓶支架	1 进口柴油机 CPC(D)20-35-HJ,D,Ku1
-	HRH24C6404 H24C6-40622	Bracket	电瓶支架	1 CPQ(D)20-35
-	H93C6-40411	Bracket	电瓶箱体	1 CPC(D)20-30-X6 CPC(D)35-X2
51	REF338624G	Bracket	电瓶固定支架	1 汽油机 进口柴油机 CPC(D)20-35-HJ,D,Ku1
-	20186-40230G	Bracket	电瓶固定支架	1 CPC(D)20-30-X6 CPC(D)35-X2
52	23652-42041G	Rod	螺杆	1
53	B4910-00006	Nut	碟形螺母M6X1	1 GB62-88
54	B5210-00006	Washer	垫圈6	1 GB96-85
55	A24K6-40811	Bracket	支架	1
56	H24C6-40811	Rod,connecting	连杆	1
57	A24K6-40831	Bracket	锁环支架	1
58	Z2131-01010	Bushing	钢背轴承1010	1
59	A24K6-42511	Spring	弹簧	1
60	B5310-00010	Washer	垫圈10	1 GB97.1-85
61	B3010-04020	Pin	销4X20	1 GB91-86
62	B0430-16035	Bolt	螺栓M16X1.5X35	6 GB5785-86
63	B5050-00016	Washer,lock	垫圈16	6 GB93-87

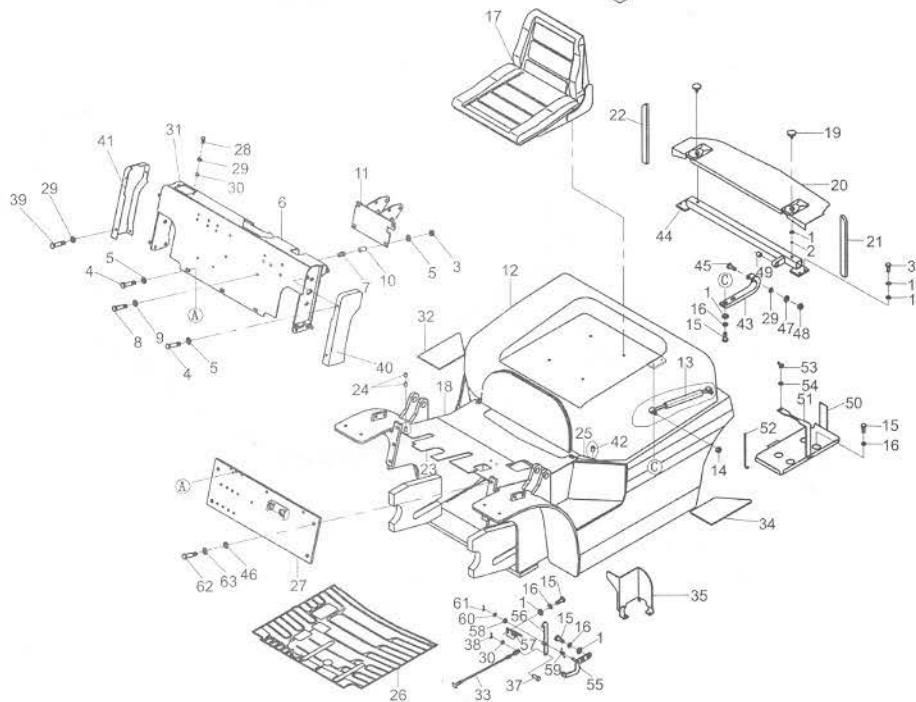
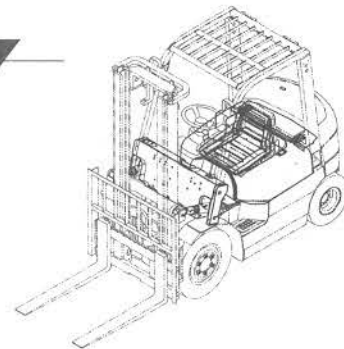
CPC,CPD20,25,30,35
CPQ,CPQD20,25,30,35

F

F3

隔热垫及垫/SEAL & INSULATOR

图102/FIG102

CPC, CPCD20, 25, 30, 35
CPQ, CPQD20, 25, 30, 35

序号 Item No	图号 Part No	零部件名称 Description	件数 Q'ty	备注 Remark
01	HRH24C6517	Insulator, rear	1	除CPC20~35-D
	H24C6-52512			CPQ20~35-ZJ3
-	HRH24C6517	Insulator, rear	1	除CPCD20~35-D
	H25S6-52512			CPQD20~35-ZJ3
-	HRH99Y6505	Insulator, rear	1	CPC20~35-D
	H99Y6-52021			CPQ20~35-ZJ3
-	HRH99Y6505	Insulator, rear	1	CPCD20~35-D
	H99Z6-52021			CPQD20~35-ZJ3
02	H24C6-52522	Insulator, front, L.H.	1	前底板隔音垫 (左)
03	H24C6-52531	Insulator, front, R.H.	1	前底板隔音垫 (右)
04	H24C6-52541	Insulator, rear, cover	1	围板隔音垫
05	HRA22A6407	Edging	1	密封条L=870
06	A24K6-43021	Edging	1	密封条L=820
07	HRA22A6408	Edging	1	密封条L=1080
08	H24C6-40711	Edging	1	密封条
09	H24C6-42722	Insulator	1	隔热垫
10	H24C6-42731	Clip	10	卡子



图103/FIG103

液压油箱/OIL TANK

G1

序号 Item No	图号 Part No	零部件名称 Description	件数 Q'ty	备注 Remark
01	H24C7-52101	Oiling cap · 加油盖	1	
02	H24C7-50102	Cover plate ass'y 盖板总成	1	除CPC(D)20-35- HJ,Ku1外车型
-	H97Y7-50201	Cover plate ass'y 盖板总成	1	CPC(D)20-35-HJ,Ku1
03	H24C2-22021	Cover gasket 盖板垫	1	
04	B0330-10020	Bolt 螺栓M10x20	8	GB5783-86
05	B5050-00010	Washer,lock 垫圈10	8	GB93-87
06	H24C7-50201	Strainer 回油滤油器	1	
07	H24C7-50302	Strainer 吸油滤油器	1	
08	Z6700-03027	Washer 垫圈30	1	JB982-77
09	Z2197-52081	Drain plug 放油螺塞	1	
10	H24C7-50402	Breather 呼吸器	1	
11	Z7400-12005	Hose 胶管	1	
12	Z4710-00016	Clip 钢带型弹性环箍	2	QC/T621-1997

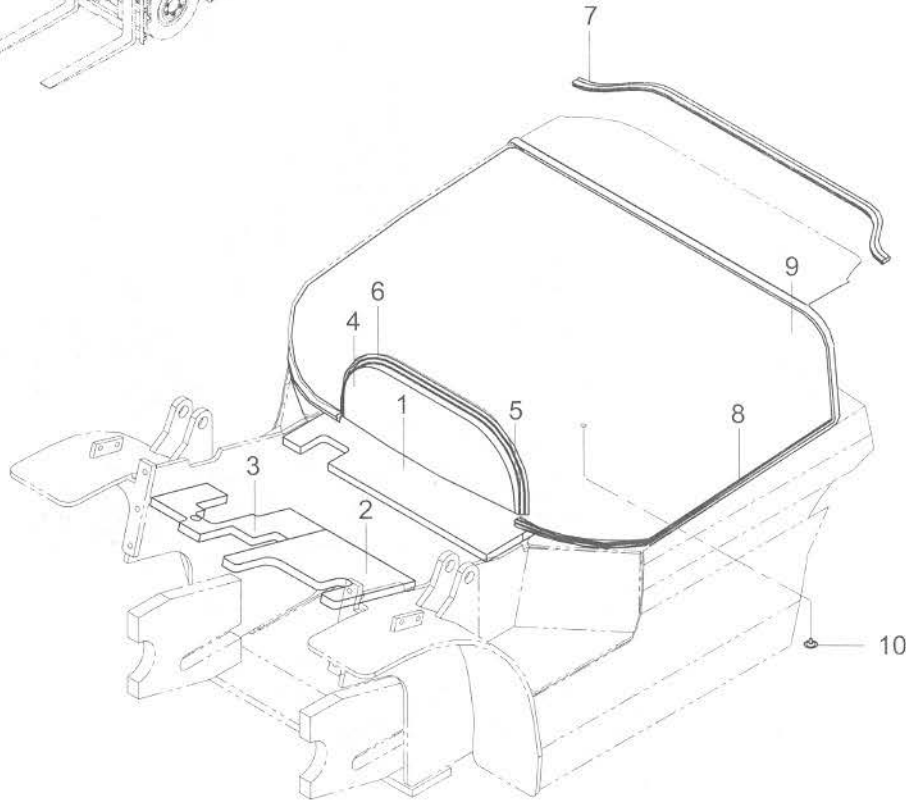
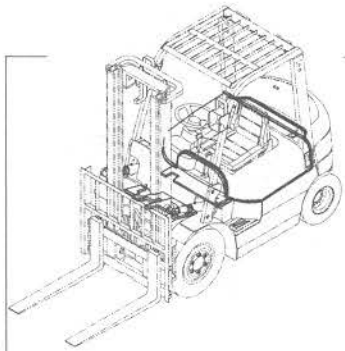
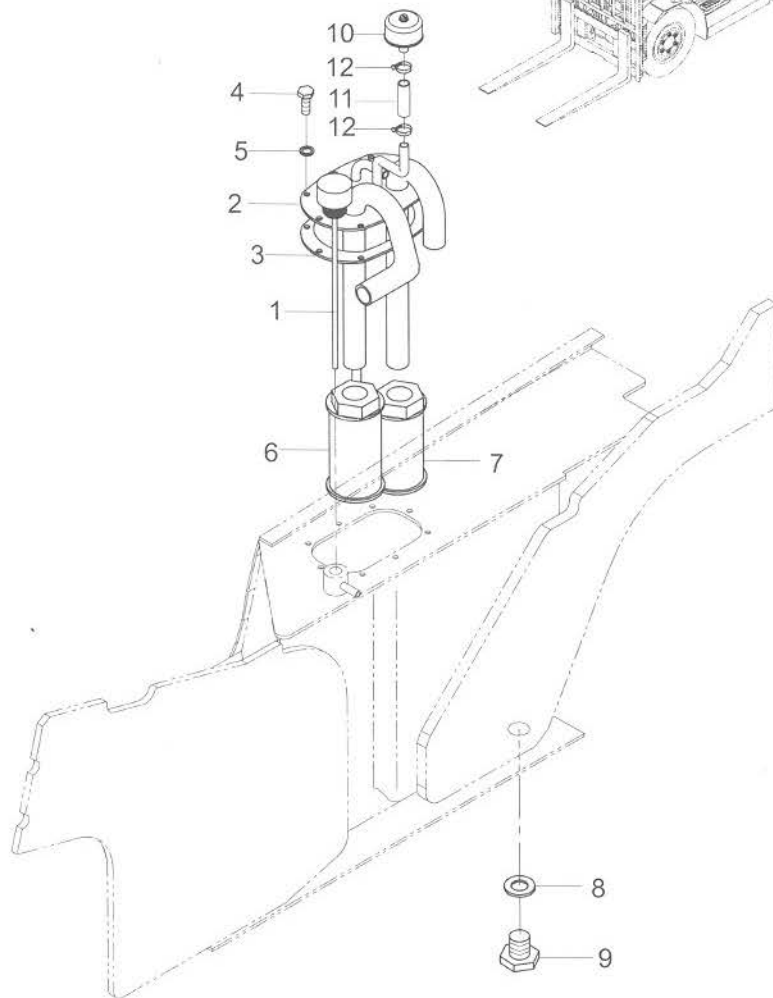
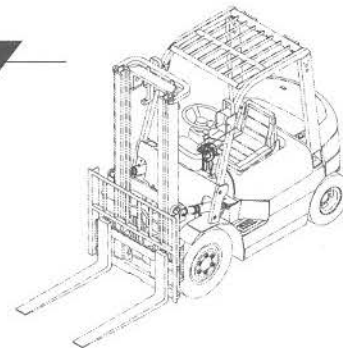
CPC, CPCD20, 25, 30, 35
CPQ, CPQD20, 25, 30, 35

G

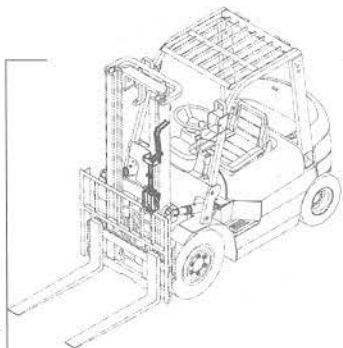

CPC, CPCD20, 25, 30, 35
CPQ, CPQD20, 25, 30, 35

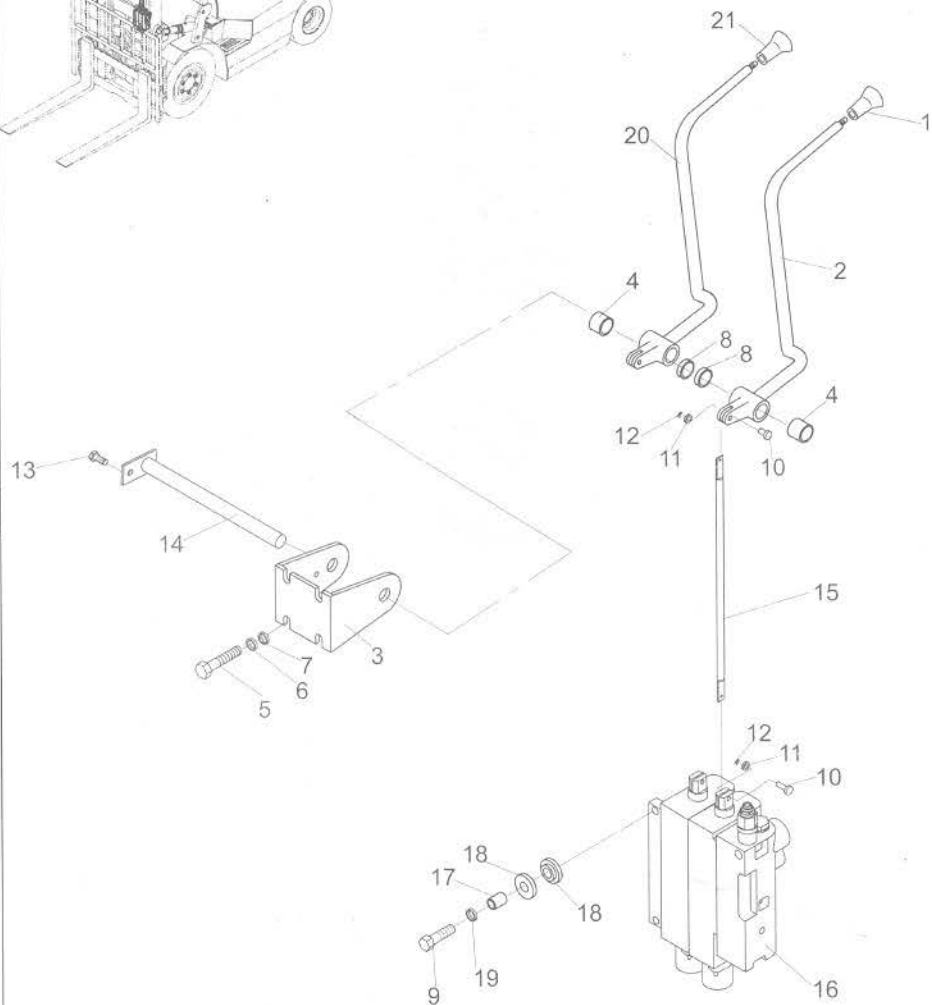

序号 Item No	图号 Part No	零部件名称 Description	件数 Q'ty	备注 Remark
01	HRA22A7406 214A7-42001	Knob, lift	升降手柄	1
02	HRH24C7403 H24C7-40101	Lever, lift	升降阀杆	1
03	HRH24C7402 H24C7-42011	Bracket, valve lever	阀杆支架	1
04	23457-42101	Bushing	衬套	2
05	B0220-08020	Bolt	螺栓M8×20	4 GB5782-86
06	B5050-00008	Washer, lock	垫圈	4 GB93-87
07	B5210-00008	Washer	垫圈	4 GB97.1-85
08	22517-40051	Shim	垫片	2
09	B0310-10035	Bolt	螺栓M10×1.25×35	3 GB5783-86
10	22717-40061	Pin	销钉	4
11	B5050-00006	Washer	垫圈	4 GB93-87
12	B3011-02012	Pin, cotter	开口销∅2×12	4 GB91-86
13	B1110-60012	Bolt	螺钉M6×12	4 GB67-85
14	23647-40041	Shaft, valve	连接轴	1
15	H24C7-42001	Joint	连接杆	2
16	HRA20A7302 A20A7-30421	Control valve	多路阀	1
17	H24C7-42101	Collar	套管	3
18	H24C7-42121	Rubber	减振垫	6
19	B5210-00010	Washer	大垫圈	3 GB96-85
20	HRH24C7403 H24C7-40201	Lever, tilt	倾斜阀杆	1
21	HRA22A7406 214A7-42011	Knob, tilt	倾斜手柄	1

序号 Item No	图号 Part No	零部件名称 Description	件数 Q'ty	备注 Remark
01	HRA22A7406 214A7-42001	Knob, lift	升降手柄	1
02	HRH24C7403 H24C7-40101	Lever, lift	升降调杆	1
03	HRH24C7402 H24C7-42021	Bracket, valve lever	阀杆支架	1
04	23457-42101	Bushing	衬套	3
05	B0220-08020	Bolt	螺栓M8×20	4 GB5782-86
06	B5050-00008	Washer, lock	垫圈8	4 GB93-87
07	B5210-00008	Washer	垫圈8	4 GB97.1-85
08	22517-40051	Shim	垫片	4
09	B0310-10035	Bolt	螺栓M10×1.25×35	3 GB5783-86
10	22717-40061	Pin	销钉	6
11	B5050-00006	Washer	垫圈6	6 GB93-87
12	B3011-02012	Pin, cotter	开口销∅2×12	6 GB91-86
13	B1110-60012	Bolt	螺钉M6×12	1 GB67-85
14	23647-40041	Shaft, valve	连接轴	1
15	H24C7-42001	Joint	连接杆	3
16	HRA20A7302 A20A7-30431	Control valve	多路阀	1
17	H24C7-42101	Coller	套管	3
18	H24C7-42121	Rubber	减振垫	6
19	B5210-00010	Washer	大垫圈10	3 GB96-85
20	23657-42131	Coller	调节套	1
21	HRH24C7403 H24C7-40201	Lever, tilt	倾斜阀杆	1
22	HRA22A7406 214A7-42011	Knob, tilt	倾斜手柄	1
23	HRH24C7403 H24C7-40301	Lever, third	第三片阀杆	1
24	HRA22A7406 514A2-72401	Knob	手柄	1

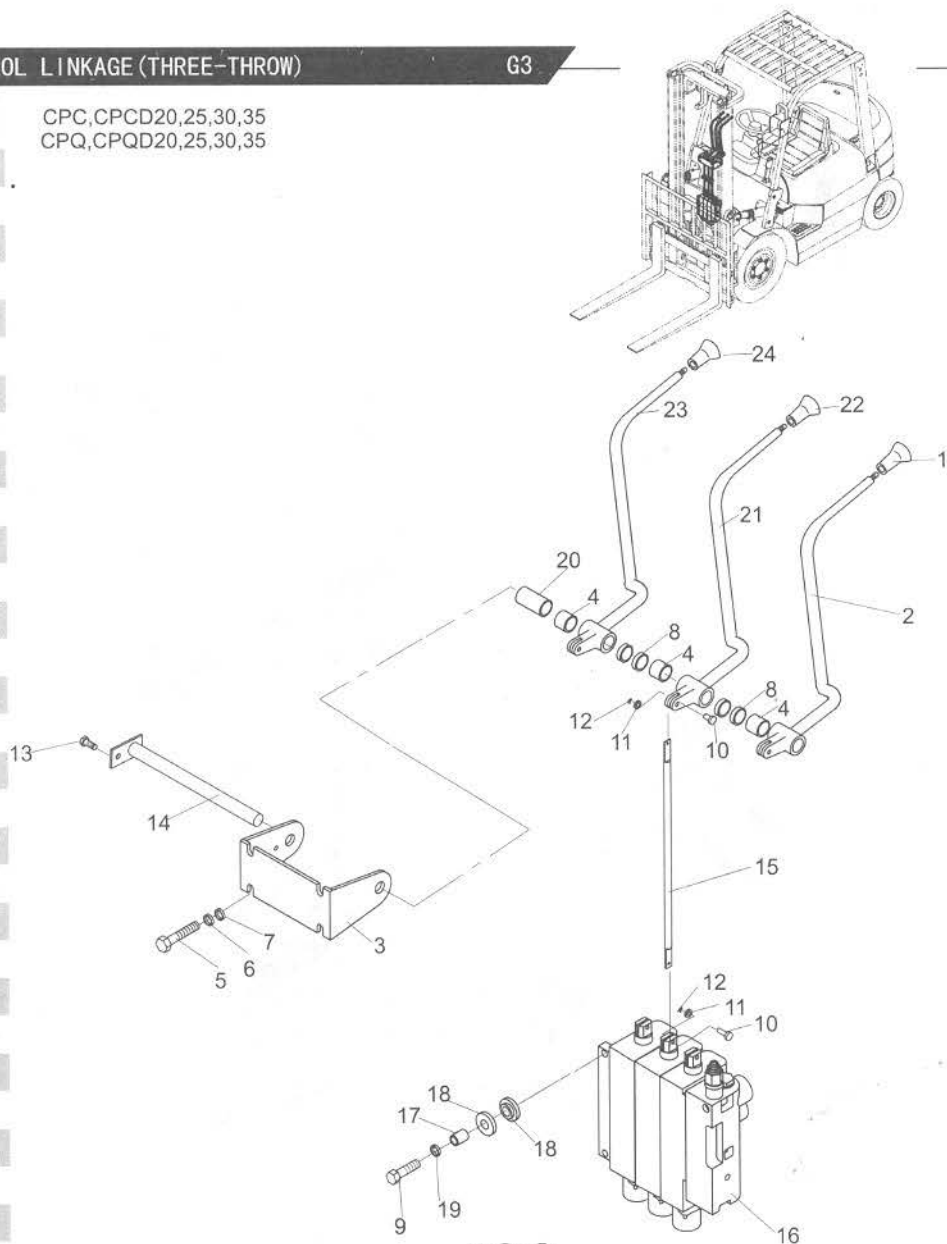
CPC, CPCD20, 25, 30, 35
CPQ, CPQD20, 25, 30, 35

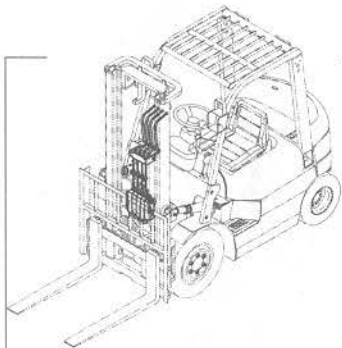

CPC,CPCD20,25,30,35
CPQ,CPQD20,25,30,35

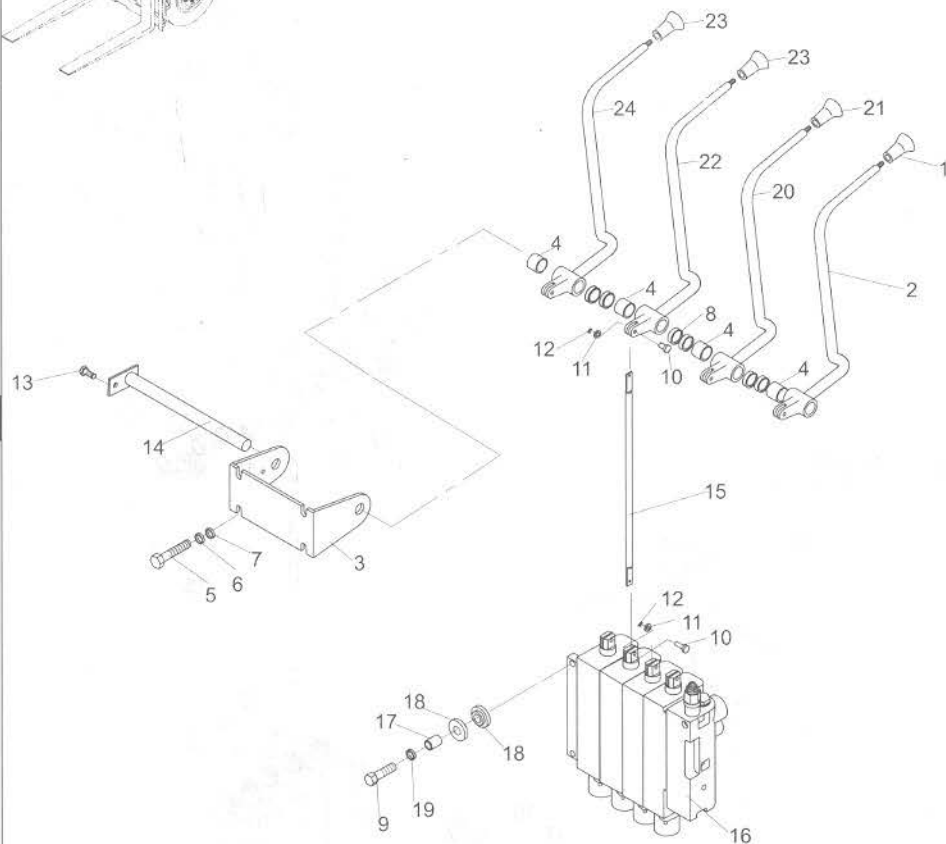

序号 Item No	图号 Part No	零部件名称 Description	件数 Q'ty	备注 Remark
01	HRA22A7406 214A7-42001	Knob, lift	升降手柄	1
02	HRH24C7403 H24C7-40101	Lever, lift	升降阀杆	1
03	HRH24C7402 H24C7-42021	Bracket, valve lever	阀杆支架	1
04	23457-42101	Bushing	衬套	4
05	B0220-08020	Bolt	螺栓M8×20	4 GB5782-86
06	B5050-00008	Washer, lock	垫圈8	4 GB93-87
07	B5210-00008	Washer	垫圈8	4 GB97.1-85
08	22517-40051	Shim	垫片	6
09	B0310-10035	Bolt	螺栓M10×1.25×35	3 GB5783-86
10	22717-40061	Pin	销钉	8
11	B5050-00006	Washer	垫圈6	8 GB93-87
12	B3011-02012	Pin, cotter	开口销∅2×12	8 GB91-86
13	B1110-60012	Bolt	螺钉M6×12	1 GB67-85
14	23647-40041	Shaft, valve	连接轴	1
15	H24C7-42001	Joint	连接杆	4
16	HRA20A7302 A20A7-30441	Control valve	多路阀	1
17	H24C7-42101	Coller	套管	3
18	H24C7-42121	Rubber	减振垫	6
19	B5210-00010	Washer	大垫圈10	3 GB96-85
20	HRH24C7403 H24C7-40201	Lever, tilt	倾斜阀杆	1
21	HRA22A7406 214A7-42011	Knob, tilt	倾斜手柄	1
22	HRH24C7403 H24C7-40301	Lever, third	第三片阀杆	1
23	HRA22A7406 514A2-72401	Knob	手柄	2
24	HRH24C7403 H24C7-40401	Lever, fourth	第四片阀杆	1

图107/FIG107

操纵杆总成(五片)/VALVE CONTROL LINKAGE (FIVE-THROW)

G5

序号 Item No	图号 Part No	零部件名称 Description	件数 Q'ty	备注 Remark
01	HRA22A7406 214A7-42001	Knob, lift	升降手柄 1	
02	HRH24C7403 H24C7-40101	Lever, lift	升降阀杆 1	
03	HRH24C7402 H24C7-42031	Bracket, valve lever	阀杆支架 1	
04	23457-42101	Bushing	衬套 5	
05	B0220-08020	Bolt	螺栓M8×20 4	GB5782-86
06	B5050-00008	Washer, lock	垫圈8 4	GB93-87
07	B5210-00008	Washer	垫圈8 4	GB97.1-85
08	22517-40051	Shim	垫片 8	
09	B0310-10035	Bolt	螺栓M10×1.25×35 3	GB5783-86
10	22717-40061	Pin	销钉 10	
11	B5050-00006	Washer	垫圈6 10	GB93-87
12	B3011-02012	Pin, cotter	开口销∅2×12 10	GB91-86
13	B1110-60012	Bolt	螺钉M6×12 1	GB67-85
14	23647-40041	Shaft, valve	连接轴 1	
15	H24C7-42001	Joint	连接杆 5	
16	HRA20A7302 A20A7-30451	Control valve	多路阀 1	
17	H24C7-42101	Coller	套管 3	
18	H24C7-42121	Rubber	减振垫 6	
19	B5210-00010	Washer	大垫圈10 3	GB96-85
20	HRH24C7403 H24C7-40201	Lever, tilt	倾斜阀杆 1	
21	HRA22A7406 214A7-42011	Knob, tilt	倾斜手柄 1	
22	HRH24C7403 H24C7-40301	Lever, third	第三片阀杆 1	
23	HRA22A7406 514A2-72401	Knob	手柄 3	
24	HRH24C7403 H24C7-40401	Lever, fourth	第四片阀杆 1	
25	HRH24C7403 H24C7-40501	Lever, fifth	第五片阀杆 1	

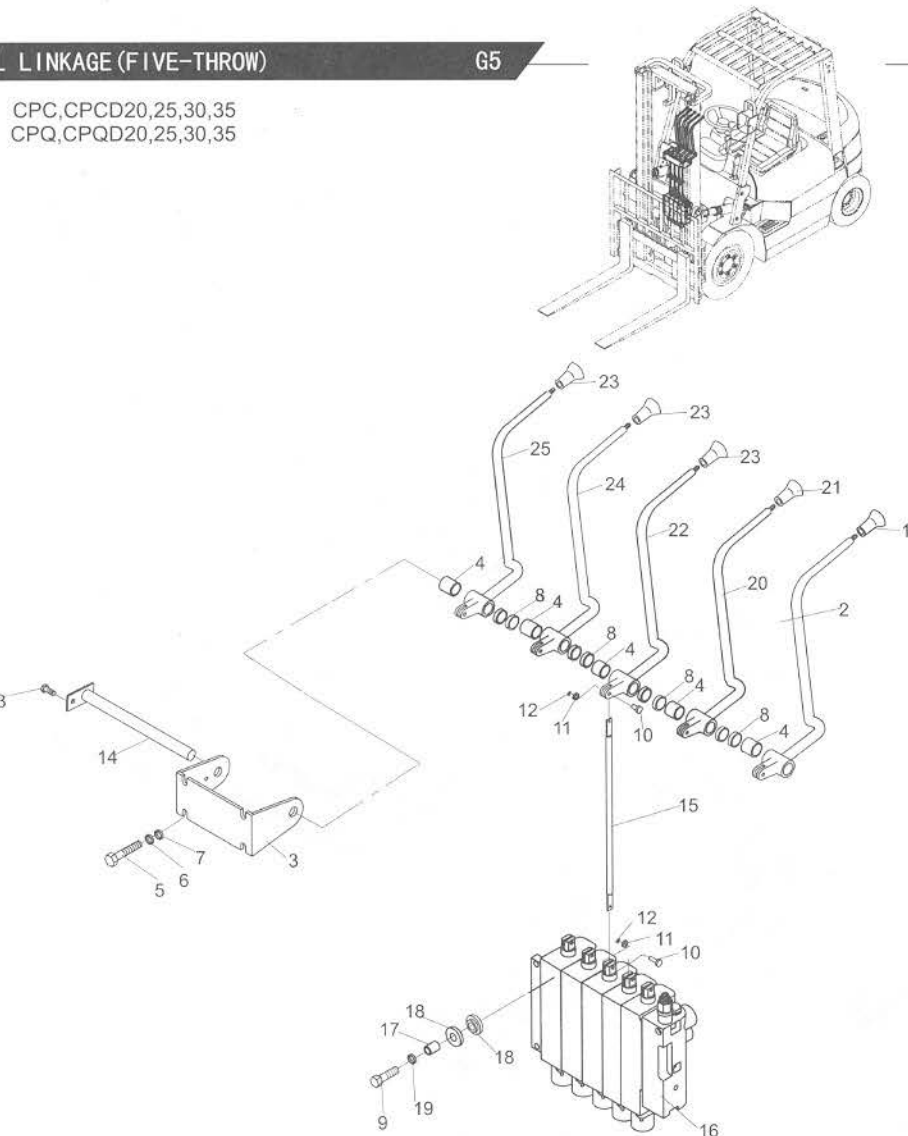

G

CPQ, CPQD20, 25, 30-R6
 CPQ, CPQD20H, 25H-R11
 CPQ, CPQD30-R12
 CPQ, CPQD35-R3, R4
 CPC, CPCD20, 25, 30, 35-W7, W8, W9
 CPC, CPCD20, 25, 30, 35-HJ, D
 CPC, CPCD35-W4, W5, W6

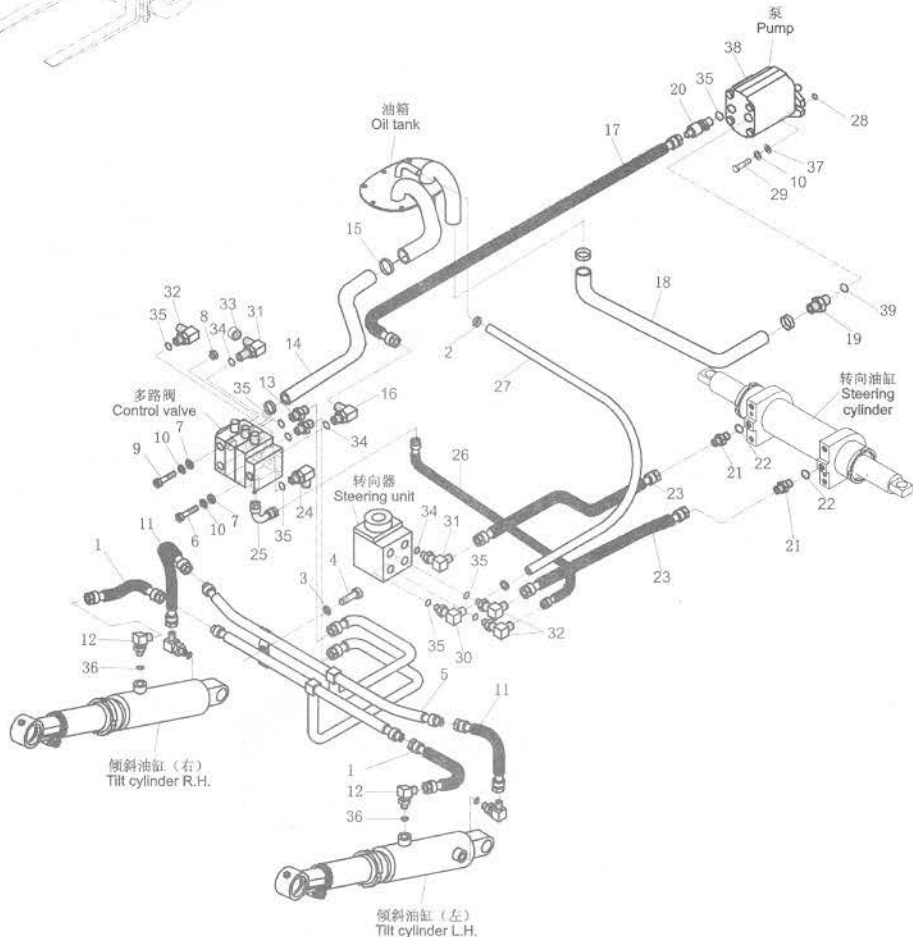
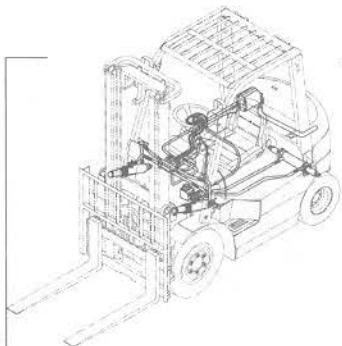

序号 Item No	图号 Part No	零部件名称 Description	件数 Q'ty	备注 Remark
A	HRE24C7601 E24C7-60002	Hydraulic system	1	2L, 2.5l
-	HRE24C7601 E24N7-60001	Hydraulic system	1	3L, 3.5l
01	E24C7-60271	Hose H.P.	2	高压胶管总成
02	Z4503-16025	Clip	2	双钢丝卡箍
03	B5050-00006	Washer, lock	9	垫圈6
04	B0330-06025	Bolt	2	螺栓M6X25
05	E24C7-60251	Steel pipe ass'y	1	倾斜缸钢管总成
06	B0530-10025	Bolt	1	螺栓M10X1.25X25
07	B5310-00010	Washer	10	垫圈10
08	B4223-00010	Nut	4	螺母M10
09	B0330-10040	Bolt	4	螺栓M10X40
10	B5050-00010	Washer, lock	12	垫圈10
11	Z7801-0603312	Hose H.P.	2	高压胶管
12	JT8022-96051	Elbow (Inc.36)	4	直角接头 (包括36)
13	JT6021-20021	Nipple (Inc.35)	2	直通接头 (包括35)
14	H24C7-60231	Hose	1	多路阀回油管 二至四片阀 Two to four-throw
-	H24C7-60241	Hose	1	多路阀回油管 五片阀 Five-throw
15	Z4590-00045	Clip	8	双钢丝卡箍
16	JT8022-34011	Elbow (Inc.34)	1	直角接头 (包括34)
17	Z7802-13117	Hose H.P.	1	高压胶管
18	H24C7-60251	Hose	1	吸油管
-	H24C7-60261	Hose	1	吸油管
				CPC(D)35-W5, W6 CPC(D)20-30-W7, W9 CPQ(D)30-R12 CPQ(D)20H, 25H-R11 CPQ(D)35-R3, R4 CPC(D)35-W4 CPC(D)20, 25-D, HJ CPC(D)30, 35-D, HJ CPQ(D)20-30-R6 CPC(D)20-30-W8
19	JT7021-10011	Nipple (Inc.39)	2	直通接头 (包括39)
20	E24C7-60291	Elbow (Inc.35)	1	齿轮油泵接头 (包括35)
-	E24C7-60321	Elbow (Inc.35)	1	齿轮油泵接头 (包括35)
				CPC(D)35-W6 CPC(D)20-30-W7, W9 CPQ(D)30-R12 CPQ(D)20H, 25H-R11 CPQ(D)35-R3, R4 CPC(D)35-W4

图108/FIG108

液压系统/HYDRAULIC SYSTEM (EX-A)

G6

序号 Item No	图号 Part No	零部件名称 Description	件数 Q'ty	备注 Remark
20	E24C7-60321	Elbow(Inc.35) 齿轮油泵接头(包括35)	1	CPC(D)20,25-D,HJ CPC(D)30,35-D,HJ CPQ(D)20~30-R6 CPC(D)20~30-W8
21	JT8025-96031	Nipple 直通接头	1	
22	Z6003-01802	O-ring 0型密封圈18X2.4	2	
23	Z7801-08208	Hose H.P. 高压胶管	2	2t,2.5t
-	Z7801-08216	Hose H.P. 高压胶管	2	3t,3.5t
24	JT8022-34031	Elbow(Inc.35) 直角接头(包括35)	1	
25	JT8022-96021	Nipple 过渡接头	1	
26	HRE22A7605 E22A7-60501	Hose H.P. 高压胶管	1	
27	Z7300-13160	Hose 低压胶管	1	
28	Z3657-12001	Packing 垫	2	柴油机
-	Z6053-08253	O-ring 0型密封圈82.5X3.55	2	汽油机 GB3452.1-82
29	B0330-10030	Bolt 螺栓M10X30	2	柴油机 GB5783-86
-	B0430-10030	Bolt 螺栓M10X1.25X30	2	汽油机 GB5785-86
30	JT6022-22041	Elbow(Inc.35) 直角接头(包括35)	1	
31	JT8022-96041	Elbow(Inc.34) 直角接头(包括34)	2	三片阀Three-throw
-			3	四片阀Four-throw
-			4	五片阀Five-throw
32	JT8022-96031	Elbow(Inc.35) 直角接头(包括35)	1	三片阀Three-throw
-			2	四片阀Four-throw
-			3	五片阀Five-throw
33	E12A7-60251	Plug 堵头	2	三片阀Three-throw
-			4	四片阀Four-throw
-			6	五片阀Five-throw
34	Z6003-02202	O-ring 0型密封圈22X2.4	9	GB1235-76 三片阀Three-throw
-			10	GB1235-76 四片阀Four-throw
-			11	GB1235-76 五片阀Five-throw
35	Z6004-02202	O-ring 0型密封圈22X2.4	9	GB1235-76 三片阀Three-throw
-			10	GB1235-76 四片阀Four-throw
-			11	GB1235-76 五片阀Five-throw

CPQ,CPQD20,25,30-R6
CPQ,CPQD20H,25H-R11
CPQ,CPQD30-R12
CPQ,CPQD35-R3,R4
CPC,CPCD20,25,30-W7,W8,W9
CPC,CPCD20,25,30,35-HJ,D
CPC,CPCD35-W4,W5,W6

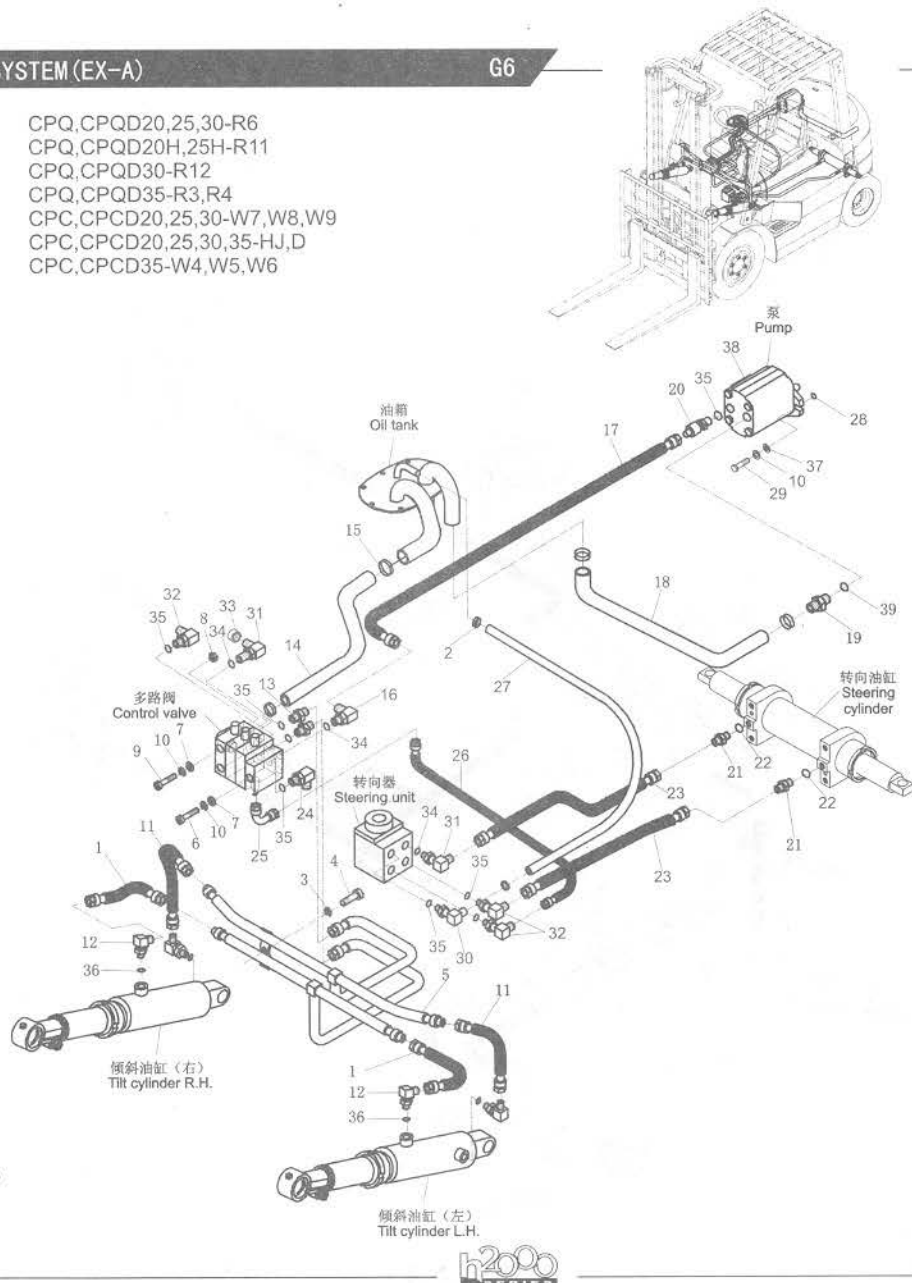

CPQ,CPQD20,25,30-R6
CPQ,CPQD20H,25H-R11
CPQ,CPQD30-R12
CPQ,CPQD35-R3,R4
CPC,CPCD20,25,30-W7,W8,W9
CPC,CPCD20,25,30,35-HJ,D
CPC,CPCD35-W4,W5,W6

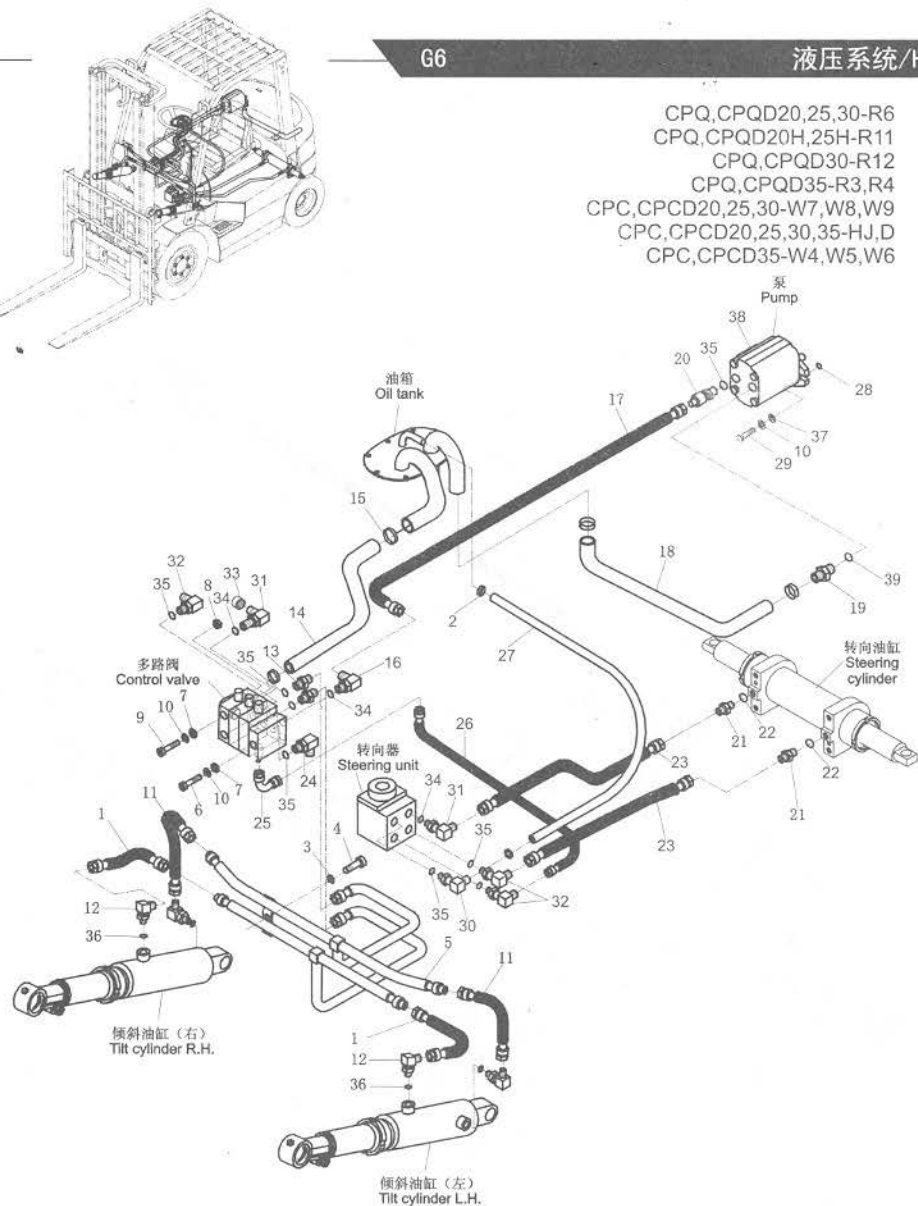

序号 Item No	图号 Part No	零件名称 Description	件数 Q'ty	备注 Remark
36	Z6003-01502	O-ring O型密封圈15X2.4	4	GB1235-76
37	B5320-00010	Washer 垫圈10	2	GB97.1-85
38	HRH24C7101 H24C7-10001	Gear pump 泵	1	CPQ(D)20,25-R6 CPC(D)20-30-W8 CPC(D)20,25-D,HJ
-	HRH24C7101 H24C7-10011	Gear pump 泵	1	CPQ(D)20H,25H-R11 CPC(D)30-R6,R12 CPC(D)30-D,HJ CPQ(D)35-R3,R4 CPC(D)35-W4,D,HJ
-	HRH24C7101 H25S7-10001	Gear pump 泵	1	CPC(D)20,25-W7,W9
-	HRH24C7101 H25S7-10011	Gear pump 泵	1	CPC(D)30-W7,W9 CPC(D)35-W5,W6
39	Z6051-02804	O-ring O型密封圈28X3.55	1	GB1235-76

图109/FIG109

液压系统/HYDRAULIC SYSTEM (EX-B)

G7

序号 Item No	图号 Part No	零部件名称 Description	件数 Q'ty	备注 Remark
A	HRH24C7601	Hydraulic system	1	2t,2.5t
-	H24C7-60002	Hydraulic system	1	3t,3.5t
-	HRH24C7601	Hydraulic system	1	3t,3.5t
-	H24N7-60001	Hydraulic system	1	3t,3.5t
01	H24C7-63021	Hose H.P.	2	
02	Z6051-02804	O-ring	1	GB1235-76
03	B5050-00006	Washer,lock	9	GB93-87
04	B0330-06025	Bolt	2	GB5783-86
05	H24C7-60601	Steel pipe ass'y	1	
06	B0530-10025	Bolt	1	GB5786-86
07	B5310-00010	Washer	10	GB97.1-85
08	B4223-00010	Nut	4	GB6171-86
09	B0330-10040	Bolt	4	GB5783-86
10	B5050-00010	Washer,lock	12	GB93-87
11	Z9501-8a03214	Hose H.P.	2	
12	JT7022-14021	Elbow(Inc.37)	4	
13	JT6021-20021	Nipple(Inc.38)	2	
14	H24C7-60231	Hose	1	二至四片阀 Two to four-throw
-	H24C7-60241	Hose	1	五片阀Five-throw
15	Z4590-00045	Clip	8	
16	JT6022-22061	Elbow(Inc.39)	1	
17	Z9502-13117	Hose H.P.	1	
18	H24C7-60251	Hose	1	CPC(D)35-W5,W6 CPC(D)20-30-W7,W9 CPQ(D)30-R12 CPQ(D)20H,25H-R11
-	H24C7-60261	Hose	1	CPQ(D)35-R3,R4 CPC(D)35-W4 CPC(D)20,25-HJ CPC(D)30,35-HJ CPQ(D)20-30-R6 CPC(D)20-30-W8
-	H24C7-60701	Hose	1	CPC(D)20-35-D
19	JT7021-10011	Nipple(Inc.02)	1	
20	H24C7-60301	Elbow(Inc.38)	1	CPC(D)35-W5,W6 CPC(D)20-30-W7,W9 CPQ(D)30-R12 CPQ(D)20H,25H-R11
-	H24C7-60221	Elbow(Inc.38)	1	CPQ(D)35-R3,R4 CPC(D)35-W4

CPQ,CPQD20,25,30-R6
CPQ,CPQD20H,25H-R11
CPQ,CPQD30-R12
CPQ,CPQD35-R3,R4
CPC,PCPD20,25,30-W7,W8,W9
CPC,PCPD20,25,30,35-HJ,D
CPC,PCPD35-W4,W5,W6

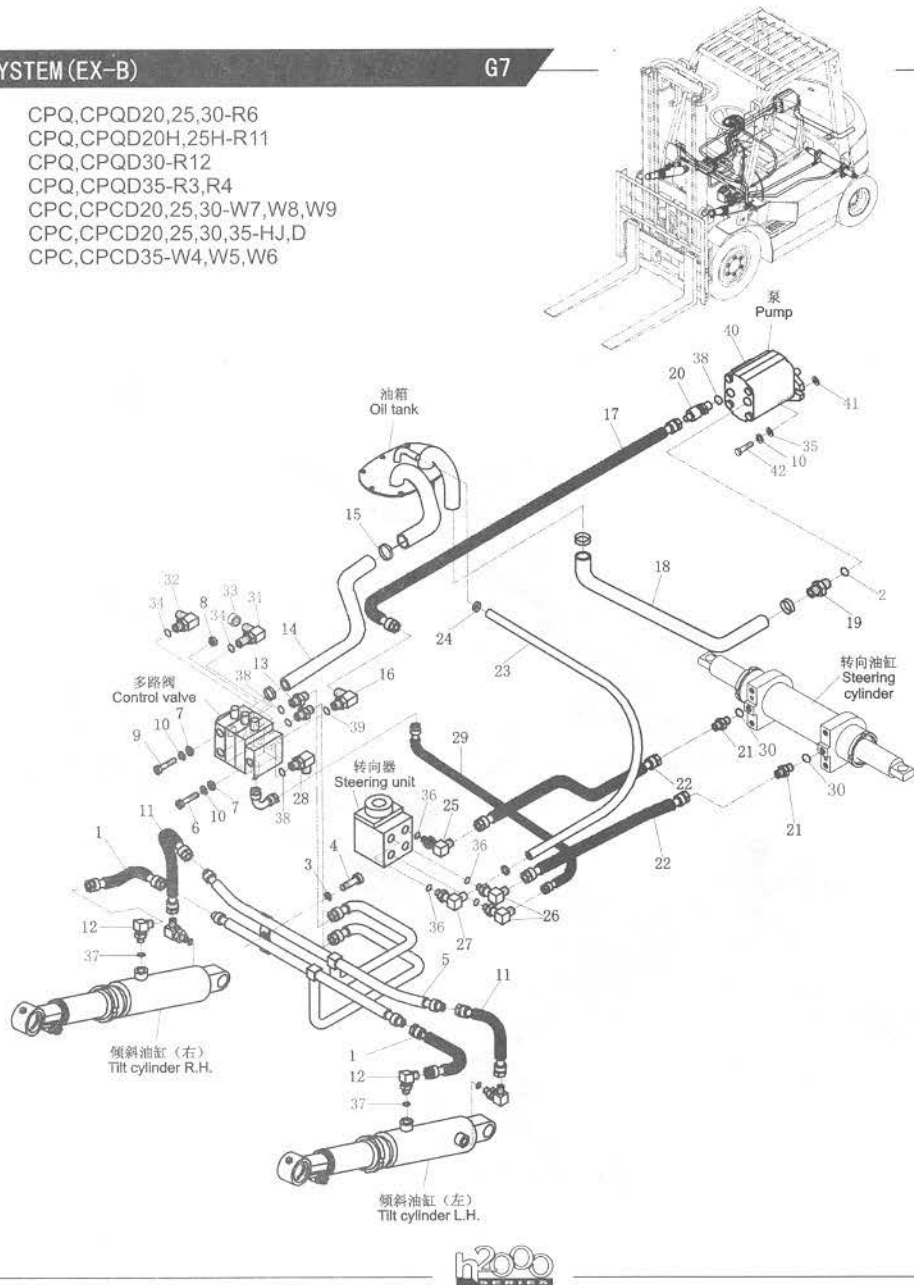

CPQ, CPQD20, 25, 30-R6
 CPQ, CPQD20H, 25H-R11
 CPQ, CPQD30-R12
 CPQ, CPQD35-R3, R4
 CPC, CPCD20, 25, 30-W7, W8, W9
 CPC, CPCD20, 25, 30, 35-HJ, D
 CPC, CPCD35-W4, W5, W6

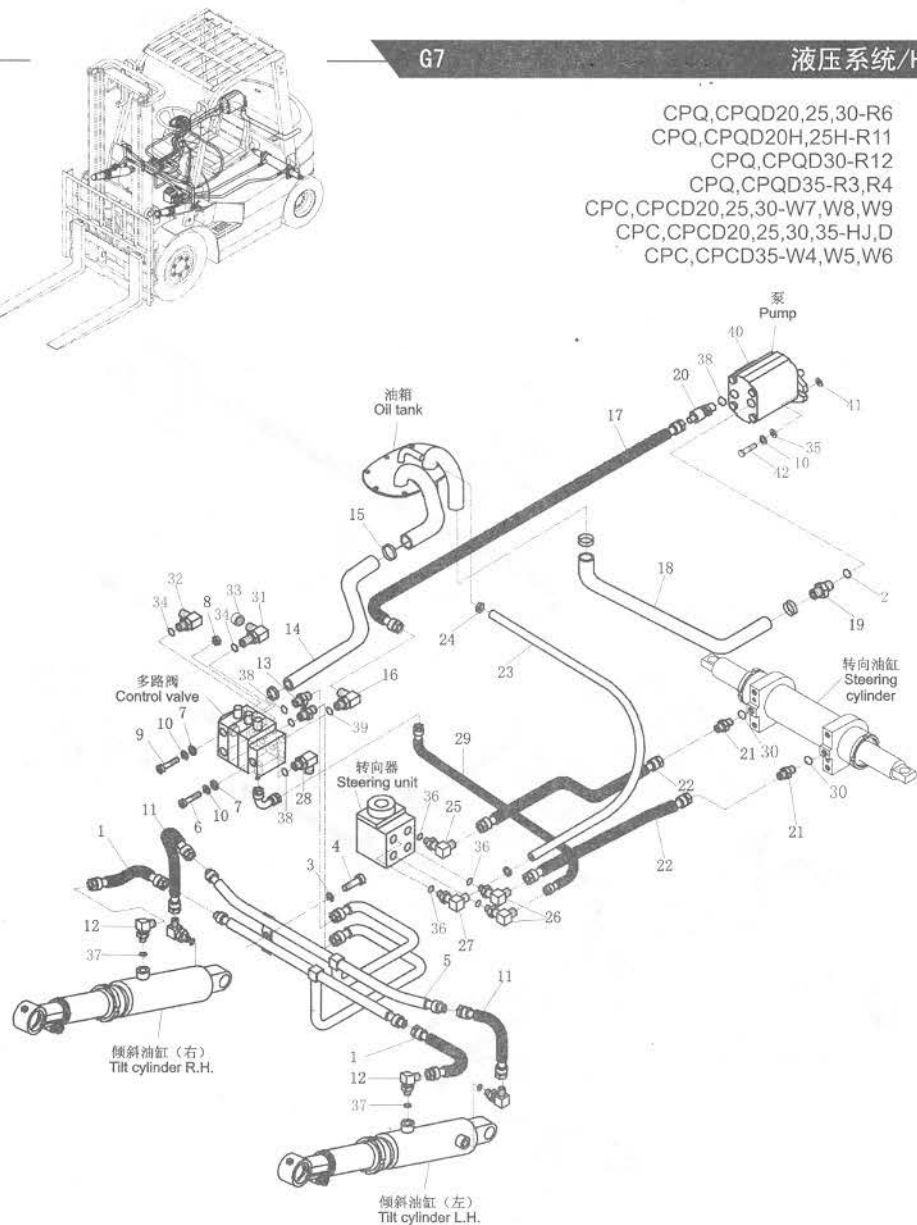

序号 Item No	图号 Part No	零部件名称 Description	件数 Q'ty	备注 Remark	
				CPC(D)20,25-D,HJ CPC(D)30,35-D,HJ CPC(D)20-30-R6 CPC(D)20-30-W8	
21	JT6025-16071	Nipple(Inc.44)	直通接头 (包括44)	2	
22	Z9501-08208	Hose H.P.	高压胶管	2	2t,2.5t
-	Z9501-08216	Hose H.P.	高压胶管	2	3t,3.5t
23	Z7300-13160	Hose	低压胶管 ϕ 13X1600	1	
24	Z4503-16025	Clip	双钢丝卡箍	2	
25	JT6022-20031	Elbow(Inc.36)	直角接头 (包括36)	1	
26	JT6022-20051	Elbow(Inc.36)	直角接头 (包括36)	2	
27	JT6022-22041	Elbow(Inc.36)	直角接头 (包括36)	1	
28	JT6026-22011	Elbow(Inc.38)	直角接头 (包括38)	1	
29	A12A7-60401	Hose H.P.	高压胶管	1	
30	B5320-00010	Washer	垫圈10	2	GB97.1-85
31	JT6022-20061	Elbow(Inc.34)	直角接头 (包括34)	1	三片阀Three-throw
-				2	四片阀Four-throw
-				3	五片阀Five-throw
32	JT6022-20071	Elbow(Inc.34)	直角接头 (包括34)	1	三片阀Three-throw
-				2	四片阀Four-throw
-				3	五片阀Five-throw
33	22497-61010	Plug	堵头	2	三片阀Three-throw
-				4	四片阀Four-throw
-				6	五片阀Five-throw
34	Z6004-01101	Ball	O型密封圈11X1.9	2	三片阀Three-throw GB1235-76
-				4	四片阀Three-throw GB1235-76
-				6	五片阀Three-throw GB1235-76
35	Z6003-01802	O-ring	O型密封圈18X2.4	2	GB1235-76
36	Z6003-02202	O-ring	O型密封圈22X2.4	1	GB1235-76
37	Z6003-01502	O-ring	O型密封圈15X2.4	4	GB1235-76
38	Z6004-02202	O-ring	O型密封圈22X2.4	8	GB1235-76
39	Z6003-02402	O-ring	O型密封圈24X2.4	1	GB1235-76

图109/FIG109

液压系统/HYDRAULIC SYSTEM (EX-B)

G7

序号 Item No	图号 Part No	零部件名称 Description	件数 Q'ty	备注 Remark
40	HRH24C7101 H24C7-10001	Gear pump	泵 1	CPQ(D)20,25-R6 CPC(D)20-30-W8 CPC(D)20,25-D,HJ
-	HRH24C7101 H24C7-10011	Gear pump	泵 1	CPQ(D)20H,25H-R11 CPQ(D)30-R6,R12 CPC(D)30-D,HJ CPQ(D)35-R3,R4 CPC(D)35-W4,D,HJ
-	HRH24C7101 H25S7-10001	Gear pump	泵 1	CPC(D)20,25-W7,W9
-	HRH24C7101 H25S7-10011	Gear pump	泵 1	CPC(D)30-W7,W9 CPC(D)35-W5,W6
41	23657-12001	Packing	垫 1	柴油机
-	Z6053-08253	O-ring	0型密封圈82.5X3.55	汽油机 GB3452.1-82
42	B0330-10030	Bolt	螺栓M10X30	柴油机 GB5783-86
-	B0430-10030	Bolt	螺栓M10X1.25X30	汽油机 GB5785-86

CPQ,CPQD20,25,30-R6
CPQ,CPQD20H,25H-R11
CPQ,CPQD30-R12
CPQ,CPQD35-R3,R4
CPC,CPCD20,25,30-W7,W8,W9
CPC,CPCD20,25,30,35-HJ,D
CPC,CPCD35-W4,W5,W6

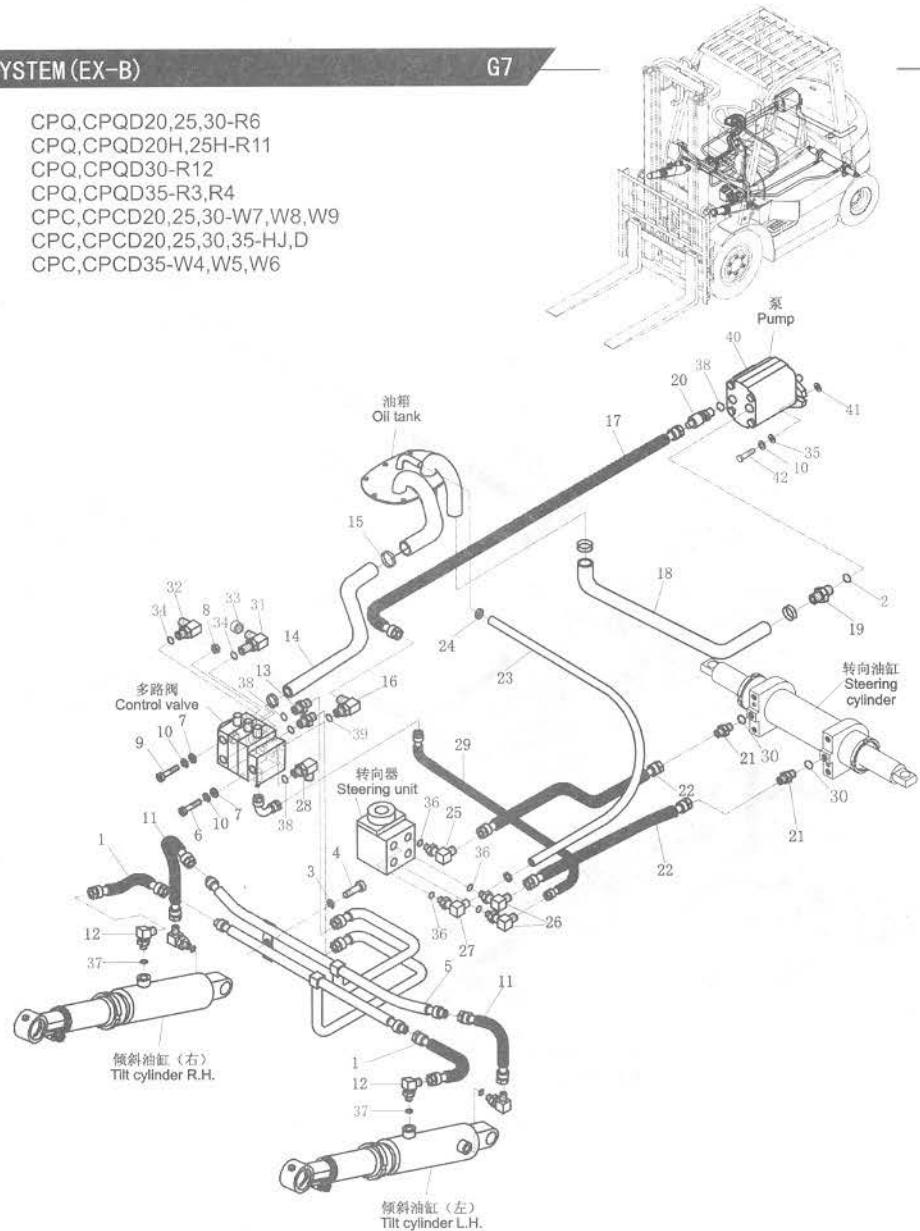

CPQ,CPQD20,25,30,35-ZJ2,ZJ3

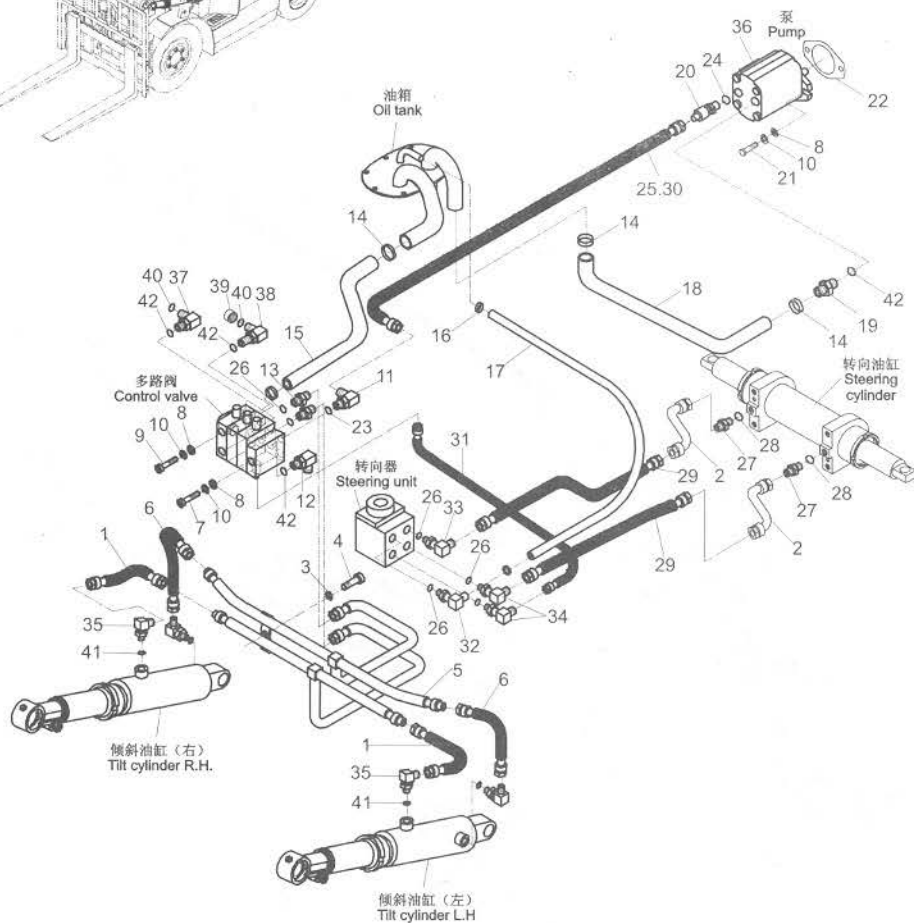
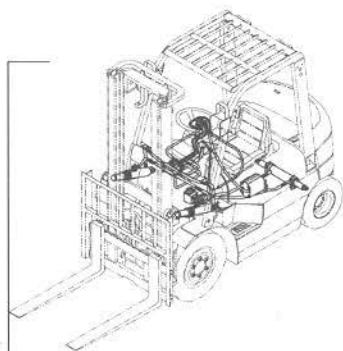

序号 Item No	图号 Part No	零部件名称 Description	件数 Q'ty	备注 Remark
A	H90Z7-60001	Hydraulic system 液压管路系统	1	
01	H24C7-63021	Hose H.P. 高压胶管	2	
02	H24N7-60201	Steering steel pipe 转向缸钢管	2	2t,2.5t
03	B5050-00006	Washer,lock 垫圈6	9	GB93-87
04	B0330-06025	Bolt 螺栓M6X25	2	GB5783-86
05	H24C7-60601	Steel pipe ass'y 倾斜缸钢管总成	1	
06	Z9501-8a03214	Hose H.P. 高压胶管	2	
07	B0530-10025	Bolt 螺栓M10X1.25X25	1	GB5786-86
08	B5310-00010	Washer 垫圈10	5	GB97.1-85
09	B0530-10030	Bolt 螺栓M10X1.25X30	2	GB5786-86
10	B5050-00010	Washer,lock 垫圈10	5	GB93-87
11	JT6022-22061	Elbow(Inc.23) 直角接头(包括23)	1	
12	JT6022-22011	Elbow(Inc.42) 直角接头(包括42)	1	
13	JT6021-20021	Nipple(Inc.26) 直通接头(包括26)	2	
14	Z4590-00045	Clip 双钢丝卡箍∅45	6	
15	H24C7-60231	Hose 多路阀回油管	1	二至四片阀 Two to four-throw
-	H24C7-60241	Hose 多路阀回油管	1	五片阀Five-throw
16	Z4590-00022	Clip 双钢丝卡箍∅22	2	
17	Z7300-13160	Hose H.P. 胶管∅13X1600	1	
18	H90Z7-62001	Hose L.P. 吸油管	1	
19	H24C7-60221	Nipple(Inc.42) 油泵接头(包括42)	1	
20	H90Z7-60201	Nipple(Inc.24) 油泵吸油接头(包括24)	1	
21	B0330-10030	Bolt 螺栓M10X30	2	GB5783-86
22	Z3657-12001	Packing 垫	1	
23	Z6003-02402	O-ring 0型密封圈24X2.4	1	GB1235-76
24	Z6053-02803	O-ring 0型密封圈28X3.55	1	GB3452.1-92
25	Z9502-13122	Hose H.P. 高压胶管13IIX1220	1	
26	Z6003-02202	O-ring 0型密封圈22X2.4	6	GB1235-76
27	JT6021-16201	Nipple(Inc.28) 直通接头(包括28)	2	
28	Z6052-01322	O-ring 0型密封圈13.2X2.65	2	GB3452.1-92

图110/FIG110

液压系统/HYDRAULIC SYSTEM

G8

序号 Item No	图号 Part No	零部件名称 Description	件数 Q'ty	备注 Remark
29	Z9501-08208	Hose H.P. 高压胶管81X2080	2	2t,2.5t
-	Z9501-08216	Hose H.P. 高压胶管81X2160	2	3t,3.5t
30	Z1197-60130	Sleeve,rubber 橡胶套	3	
31	A12A7-60401	Hose H.P. 高压胶管	1	
32	JT6022-22041	Elbow(Inc.26) 直角接头(包括26)	1	
33	JT6022-20031	Elbow(Inc.26) 直角接头(包括26)	1	
34	JT6022-20051	Elbow(Inc.26) 直角接头(包括26)	2	
35	JT7022-14021	Elbow(Inc.41) 直角接头(包括41)	4	
36	H98D7-10001	Gear pump 油泵	1	2t,2.5t
-	H90Z7-10001	Gear pump 油泵	1	3t,3.5t
37	JT6022-20061	Elbow(Inc.40,42) 直角接头(包括40,42)	1	三片阀Three-throw
			2	四片阀Four-throw
			3	五片阀Five-throw
38	JT6022-20071	Elbow(Inc.40,42) 直角接头(包括40,42)	1	三片阀Three-throw
			2	四片阀Four-throw
			3	五片阀Five-throw
39	Z2497-61010	Plug 堵头	2	三片阀Three-throw
			4	四片阀Four-throw
			6	五片阀Five-throw
40	Z6004-01101	O-ring 0型密封圈11X1.9	2	GB1235-76
			4	三片阀Three-throw
			4	四片阀Four-throw
			6	五片阀Five-throw
41	Z6003-01502	O-ring 0型密封圈15X2.4	4	GB1235-76
42	Z6004-02202	O-ring 0型密封圈22X2.4	2	GB1235-76
			4	二片阀Two-throw
			4	三片阀Three-throw
			6	四片阀Four-throw
			8	五片阀Five-throw

CPQ,CPQD20,25,30,35-ZJ2,ZJ3

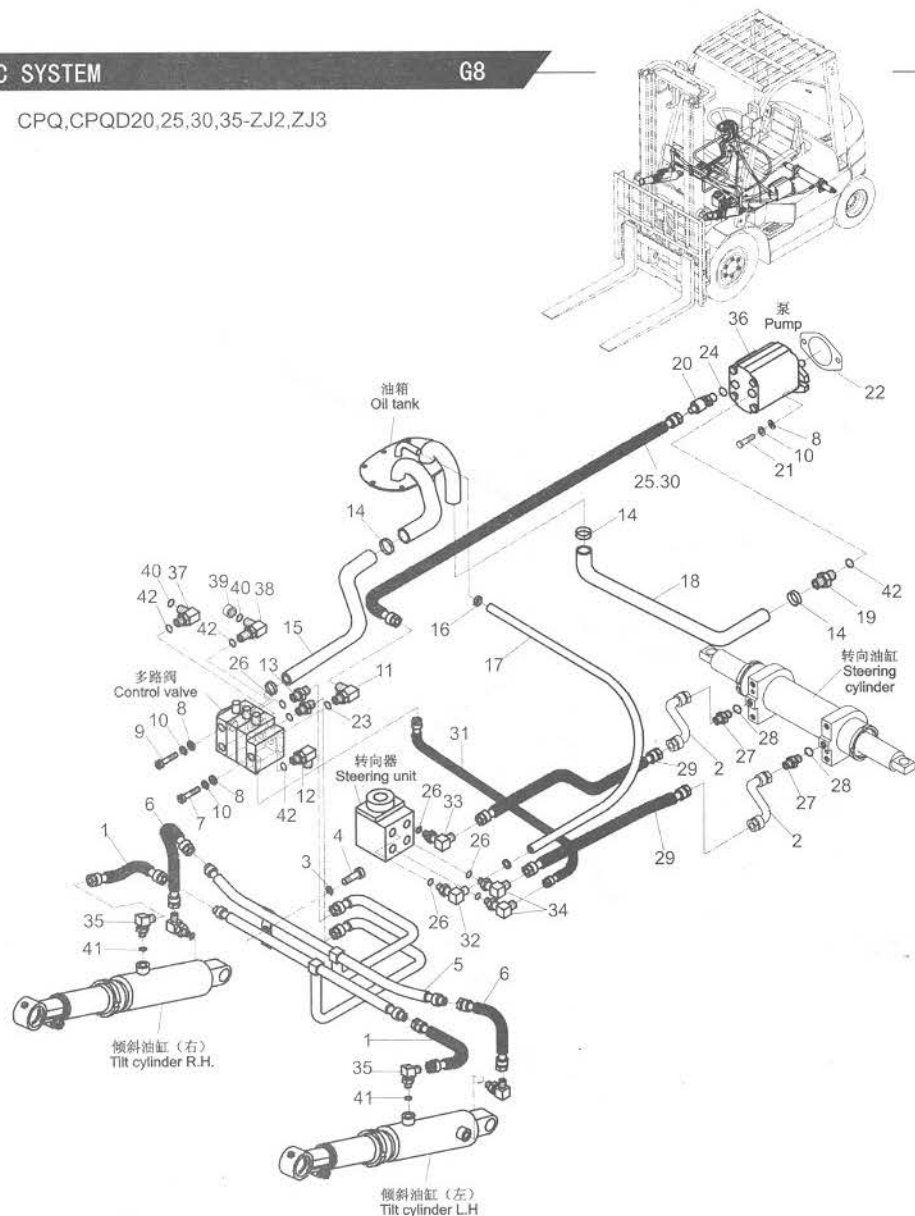

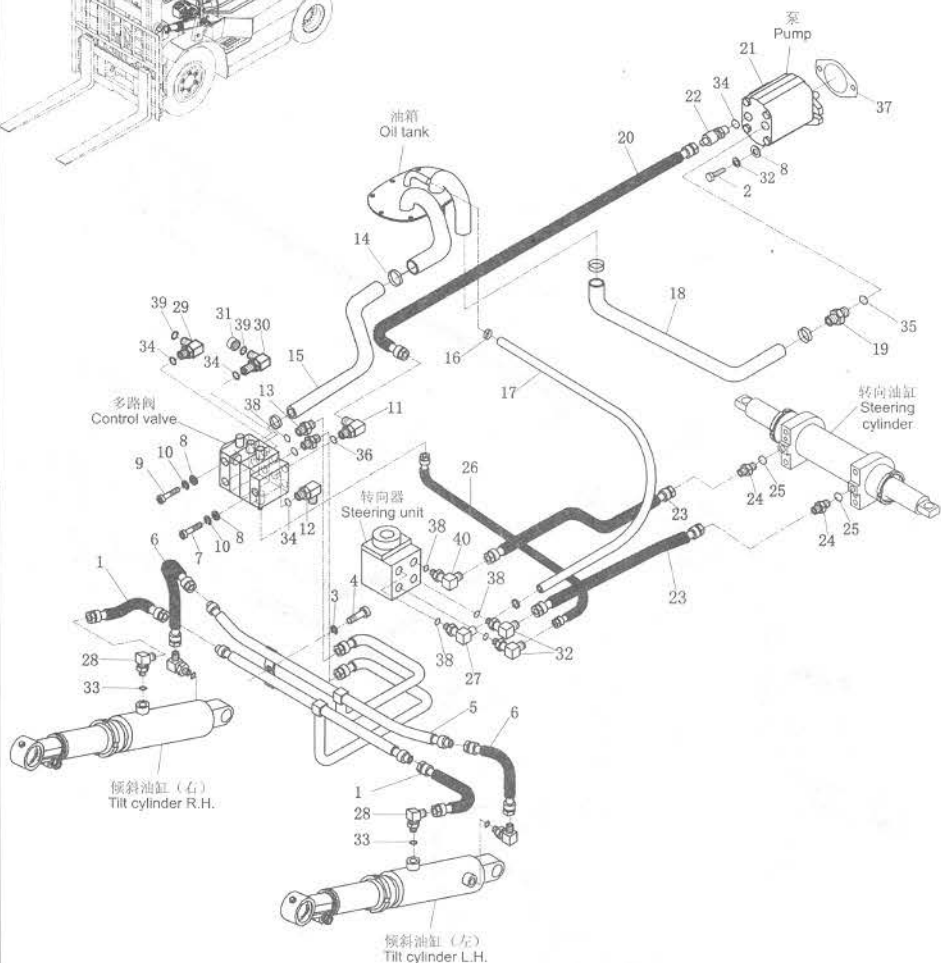
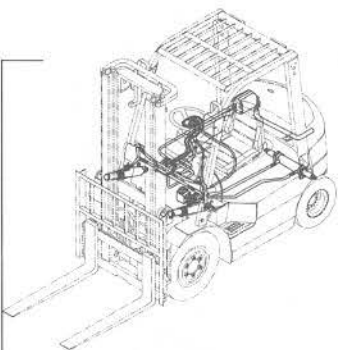
CPC,CPCD20,25,30-X6
CPC,CPCD35-X2

序号 Item No	图号 Part No	零件名称 Description	件数 Q'ty	备注 Remark
A	HRH93C7601 H93C7-60001 HRH93C7601 H93N7-60001	Hydraulic system 液压管路系统	1	2t,2.5t
-		Hydraulic system 液管管路系统	1	3t,3.5t
01	H24C7-63021	Hose H.P. 高压胶管总成	2	
02	B0330-10030	Bolt 螺栓M10X30	2	GB5783-86
03	B5050-00006	Washer,lock 垫圈6	9	GB93-87
04	B0330-06025	Bolt 螺栓M6X25	2	GB5783-86
05	H24C7-60601	Steel pipe ass'y 倾斜缸钢管总成	1	
06	Z9501-8a03614	Hose H.P. 高压胶管(玛努利管)	2	
07	B0530-10025	Bolt 螺栓M10X1.25X25	1	GB5786-86
08	B5310-00010	Washer 垫圈10	5	GB97.1-85
09	B0530-10030	Bolt 螺栓M10X1.25X30	2	GB5786-86
10	B5050-00010	Washer,lock 垫圈10	5	GB93-87
11	JT6022-22061	Elbow(Inc.36) 直角接头(包括36)	1	
12	JT6026-22011	Elbow(Inc.34) 直角接头(包括34)	1	
13	JT6021-20021	Nipple(Inc.38) 直通接头(包括38)	2	
14	Z4590-00045	Clip 双钢丝卡箍∅45	6	
15	H24C7-60231	Hose 多路阀回油管	1	二至四片阀 Two to four-throw
-	H24C7-60241	Hose 多路阀回油管	1	五片阀Five-throw
16	Z4590-00022	Clip 双钢丝卡箍∅22	2	
17	Z7300-13160	Hose L.P. 低压胶管∅13X1600	1	
18	H93C7-62021	Hose 吸油管	1	
19	JT7021-10011	Elbow(Inc.35) 直角接头(包括35)	1	
20	HRA22A7603*117	Hose H.P. 高压胶管811X1170	1	
21	H93C7-10001	Pump 泵	1	2t,2.5t
-	H93N7-10001	Pump 泵	1	3t,3.5t
22	H24C7-60301	Elbow(Inc.34) 油泵接头(包括34)	1	
23	HRA20A7652*208	Hose H.P. 高压胶管81X2080	2	2t,2.5t
-	HRA20A7652*216	Hose H.P. 高压胶管81X2160	2	3t,3.5t
24	JT6025-16071	Nipple 直角接头体	2	
25	Z6003-01802	O-ring O型密封圈18X2.4	2	GB1235-76

图111/FIG111

液压系统/HYDRAULIC SYSTEM

G9

序号 Item No	图号 Part No	零部件名称 Description	件数 Qty	备注 Remark
26	A12A7-60401	Hose H.P. 高压胶管	1	
27	JT6022-22041	Elbow(Inc.38) 直角接头(包括38)	1	
28	JT7022-14021	Elbow(Inc.33) 直角接头(包括33)	4	
29	JT6022-20061	Elbow(Inc.34,39) 直角接头(包括34, 39)	1	三片阀Three-throw
			2	四片阀Four-throw
			3	五片阀Five-throw
30	JT6022-20071	Elbow(Inc.34,39) 直角接头(包括34, 39)	1	三片阀Three-throw
			2	四片阀Four-throw
			3	五片阀Five-throw
31	22497-61010	Plug 堵头	2	三片阀Three-throw
			4	四片阀Four-throw
			6	五片阀Five-throw
32	JT6022-20051	Elbow(Inc.38) 直角接头(包括38)	2	
33	Z6003-01502	O-ring 0型密封圈15X2.4	4	GB1235-76
34	Z6004-02202	O-ring 0型密封圈22X2.4	2	GB1235-76
			4	三片阀Three-throw GB1235-76
			6	四片阀Four-throw GB1235-76
			8	五片阀Five-throw GB1235-76
35	Z6051-02804	O-ring 0型密封圈28X3.55	1	GB3452.1-92
36	Z6003-02402	O-ring 0型密封圈24X2.4	1	GB1235-76
37	23657-12001	Packing 垫	1	
38	Z6003-02202	O-ring 0型密封圈22X2.4	6	GB1235-76
39	Z6004-01101	O-ring 0型密封圈11X1.9	2	GB1235-76
			4	三片阀Three-throw GB1235-76
			6	四片阀Four-throw GB1235-76
			6	五片阀Five-throw GB1235-76
40	JT6022-20031	Elbow(Inc.38) 直角接头(包括38)	1	

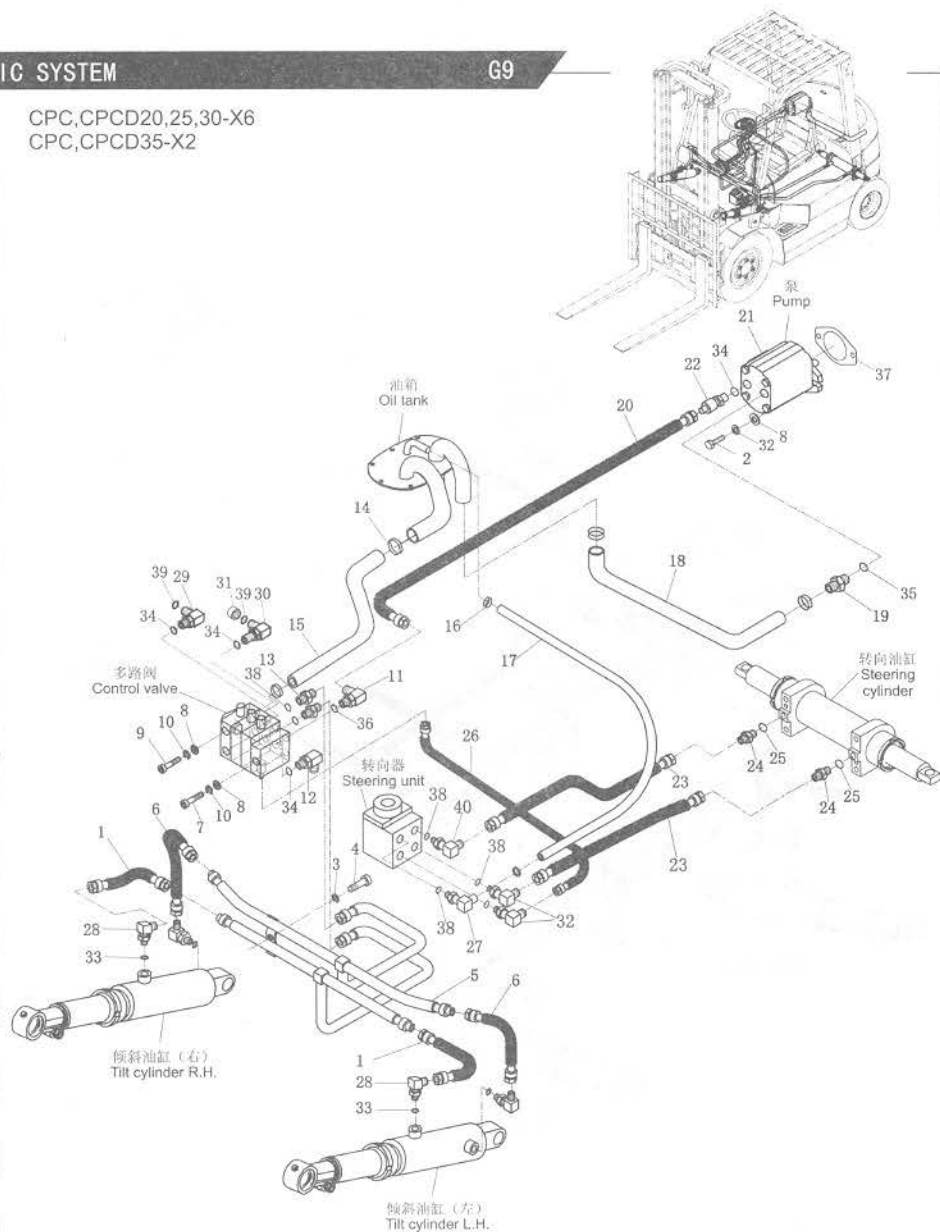
CPC,CPCD20,25,30-X6
CPC,CPCD35-X2

h2000

CPC, CPCD20, 25, 30, 35-Xs1

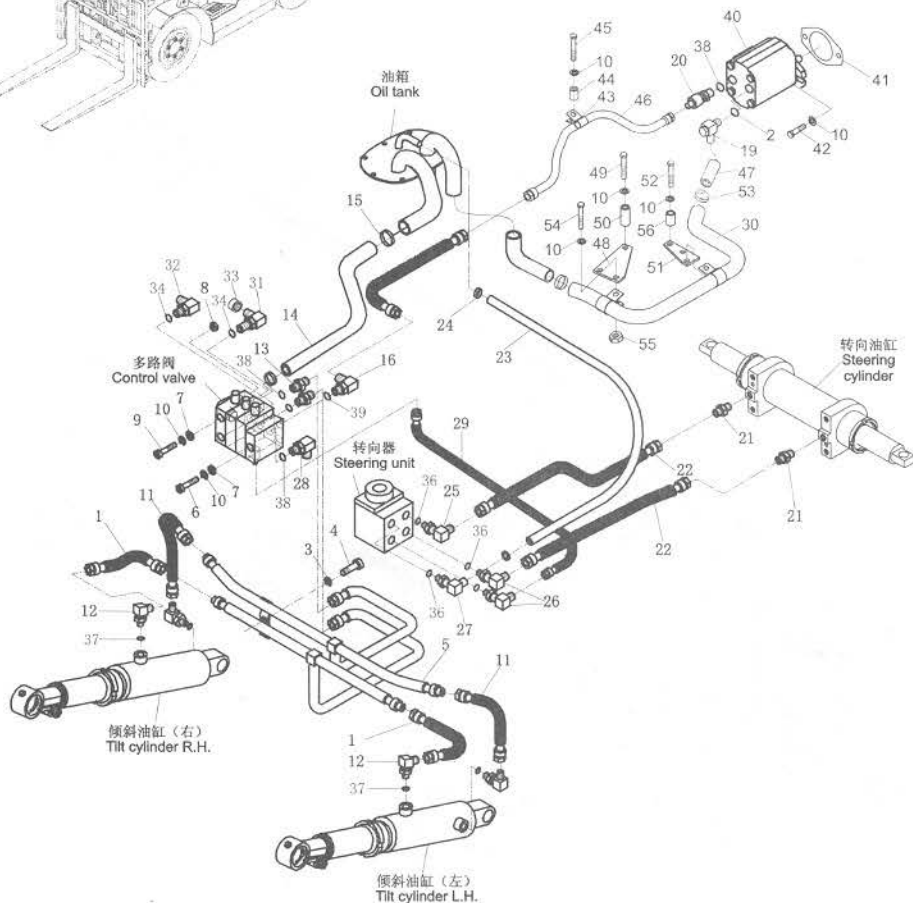
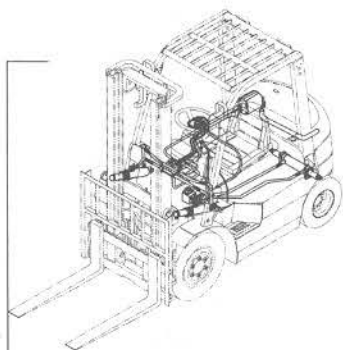

序号 Item No	图号 Part No	零部件名称 Description	件数 Q'ty	备注 Remark
A	HRH2A17601	Hydraulic system	1	2t, 2.5t
-	H2A17-60001	Hydraulic system	1	3t, 3.5t
-	HRH2A17601	Hydraulic system	1	3t, 3.5t
-	H2F17-60001	Hydraulic system	1	3t, 3.5t
01	H24C7-63021	Hose H.P.	2	高压胶管
02	Z6053-02803	O-ring	1	O型密封圈 GB3452.1-92
03	B5050-00006	Washer, lock	9	垫圈 GB93-87
04	B0330-06025	Bolt	2	螺栓 M6X25 GB5783-86
05	H24C7-60601	Steel pipe ass'y	1	倾斜斜钢管总成
06	B0530-10025	Bolt	1	螺栓 M10X1.25X25 GB5786-86
07	B5310-00010	Washer	10	垫圈 GB97.1-85
08	B4223-00010	Nut	4	螺母 M10 GB6171-86
09	B0330-10040	Bolt	4	螺栓 M10X40 GB5783-86
10	B5050-00010	Washer, lock	12	垫圈 GB93-87
11	Z9501-8a03214	Hose H.P.	2	高压胶管
12	JT7022-14021	Elbow(Inc.37)	4	直角接头(包括37)
13	JT6021-20021	Nipple(Inc.36)	2	直通接头(包括36)
14	H24C7-60231	Hose	1	多路阀回油管 二至四片阀 Two to four-throw
-	H24C7-60241	Hose	1	多路阀回油管 五片阀 Five-throw
15	Z4590-00045	Clip	8	双钢丝卡箍 $\phi 45$
16	JT6022-22061	Elbow(Inc.39)	1	直角接头(包括39)
17	Z9502-13082	Hose H.P.	1	高压胶管
18	H21U7-62001	Hose	1	吸油管
19	JT7022-10031	Elbow(Inc.02)	1	直角接头(包含02)
20	JT7021-12051	Nipple(Inc.36)	1	直通接头(包含36)
21	JT6025-16071	Nipple	2	直通接头
22	Z9501-08208	Hose H.P.	2	高压胶管 2t, 2.5t
-	Z9501-08216	Hose H.P.	2	高压胶管 2.8t, 3.5t
23	Z7300-13160	Hose	1	
24	Z4503-16025	Clip	2	双钢丝卡箍
25	JT6022-20031	Elbow(Inc.36)	1	直角接头(包含36)
26	JT6022-20051	Elbow(Inc.36)	2	直角接头(包含36)

图112/FIG112

液压系统/HYDRAULIC SYSTEM

G10

序号 Item No	图号 Part No	零部件名称 Description	件数 Q'ty	备注 Remark
27	JT6022-22041	Elbow(Inc.36) 直角接头(包括36)	1	
28	JT6022-22011	Elbow(Inc.38) 直角接头(包括38)	1	
29	A12A7-60401	Hose H.P. 高压胶管	1	
30	H2A17-62001	Steel pipe 吸油钢管	1	
31	JT6022-20061	Elbow(Inc.34,38) 直角接头(包含34, 38)	1	三片阀Three-throw
-			2	四片阀Four-throw
-			3	五片阀Five-three
32	JT6022-20071	Elbow(Inc.34,38) 直角接头(包含34, 38)	1	三片阀Three-throw
-			2	四片阀Four-throw
-			3	五片阀Five-three
33	22497-61010	Plug 堵头	2	三片阀Three-throw
-			4	四片阀Four-throw
-			6	五片阀Five-three
34	Z6004-01101	Ball 0型密封圈11X1.9	2	三片阀Three-throw GB1235-76
-			4	四片阀Three-throw GB1235-76
-			6	五片阀Three-throw GB1235-76
35	Z6003-01802	O-ring 0型密封圈18X2.4	2	GB1235-76
36	Z6003-02202	O-ring 0型密封圈22X2.4	1	GB1235-76
37	Z6003-01502	O-ring 0型密封圈15X2.4	4	GB1235-76
38	Z6004-02202	O-ring 0型密封圈22X2.4	8	GB1235-76
39	Z6003-02402	O-ring 0型密封圈22X2.4	1	GB1235-76
40	HRH24C7101 H25S7-10001	Gear pump 齿轮油泵	1	2.2.5t
-	HRH24C7101 H25S7-10011	Gear pump 齿轮油泵	1	3.3.5t
41	23657-12001	Packing 垫	1	
42	B0330-10030	Bolt 螺栓M10X30	2	GB5783-86
43	H2A17-62111	Clip 卡箍	2	
44	H2A17-62101	Block 垫块(三)	2	
45	B0230-10045	Bolt 螺栓M10X45	2	GB5782-86
46	H2A17-60201	Steel pipe ass'y,output 出油钢管总成	1	
47	Z7353-32070	Hose 胶管 \varnothing 32X70	1	

CPC,CPCD20,25,30,35-Xs1

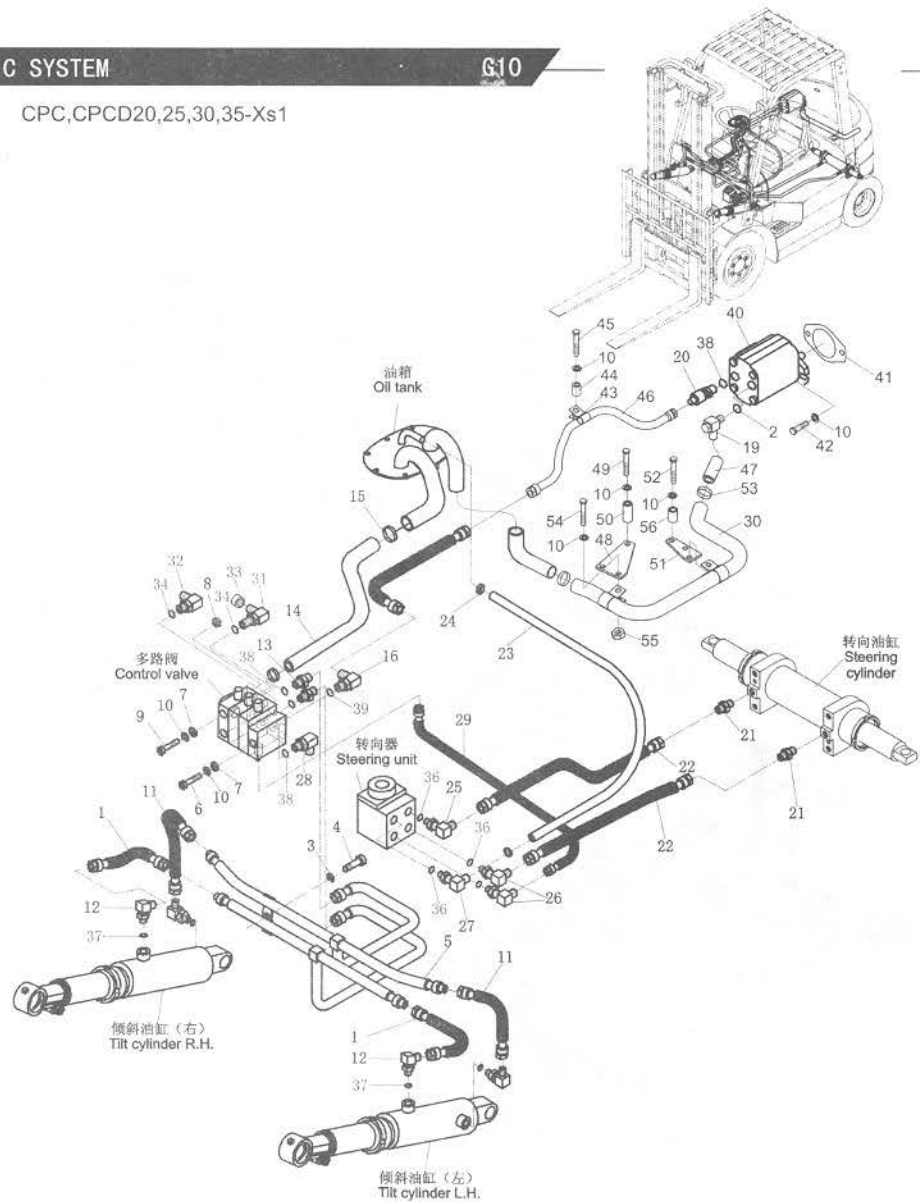

h2000

CPC,CPCD20,25,30,35-Xs1

序号 Item No	图号 Part No	零部件名称 Description	件数 Q'ty	备注 Remark
48	H2A17-62061	Plate 板(二)	1	
49	B0230-10070	Bolt 螺栓M10X70	2	GB5782-86
50	H2A17-62071	Block 垫块(二)	2	
51	H2A17-62011	Plate 板(一)	1	
52	B0230-10050	Bolt 螺栓M10X50	2	GB5782-86
53	H2A17-62051	Clip 卡箍	2	
54	B0330-10020	Bolt 螺栓M10X20	2	GB5783-86
55	B4116-00010	Nut 螺母M10	4	GB6170-86
56	H2A17-62031	Block 垫块	2	



图113/FIG113

液压系统/HYDRAULIC SYSTEM(EX-B)

G11

序号 Item No	图号 Part No	零部件名称 Description	件数 Q'ty	备注 Remark
A	HRH2B97601 H2F97-60001	Hydraulic system	1	2t
-	HRH2B97601 H2F97-60001	Hydraulic system	1	2.5t
-	HRH2B97601 H2F97-60001	Hydraulic system	1	3t
01	H24C7-63021	Hose H.P.	1	高压胶管总成
02	Z6051-02804	O-ring	2	0型密封圈28X3.55 GB1235-76
03	B5050-00006	Washer,lock	9	垫圈6 GB93-87
04	B0330-06025	Bolt	2	螺栓M6X25 GB5783-86
05	H24C7-60601	Steel pipe ass'y	1	倾斜缸钢管总成
06	B0530-10025	Bolt	1	螺栓M10X1.25X25 GB5786-86
07	B5310-00010	Washer	10	垫圈10 GB97.1-85
08	B4223-00010	Nut	4	螺母M10X1.25 GB6171-86
09	B0330-10040	Bolt	4	螺栓M10X40 GB5783-86
10	B5050-00010	Washer,lock	10	垫圈10 GB93-87
11	Z9501-8a03614	Hose H.P.	2	高压胶管
12	JT7022-14021	Elbow(Inc.37)	4	直角接头(包括37)
13	JT6021-20021	Nipple(Inc.38)	2	直通接头(包括38)
14	H24C7-60231	Hose	1	多路阀回油管 二至四片阀
-	H24C7-60241	Hose	1	多路阀回油管 五片阀Five-throw
15	Z4590-00045	Clip	8	双钢丝卡箍 \varnothing 45
16	JT6022-22061	Elbow(Inc.39)	1	直角接头(包括39)
17	Z9502-13117	Hose H.P.	1	高压胶管13 \square X1170
18	H2B97-62004	Hose	1	吸油管
19	JT7021-10011	Nipple(Inc.02)	1	直通接头(包括02)
20	H24C7-60221	Elbow(Inc.38)	1	油泵接头(包括38)
21	JT6025-16071	Nipple	2	直通接头
22	Z9501-08208	Hose H.P.	2	高压胶管 2t,2.5t
-	Z9501-08216	Hose H.P.	2	高压胶管 3t
23	Z7300-13160	Hose H.P.	1	低压胶管 \varnothing 13X1600
24	Z4503-16025	Clip	2	喉箍16-25
25	JT6022-20031	Elbow(Inc.36)	1	直角接头(包括36)

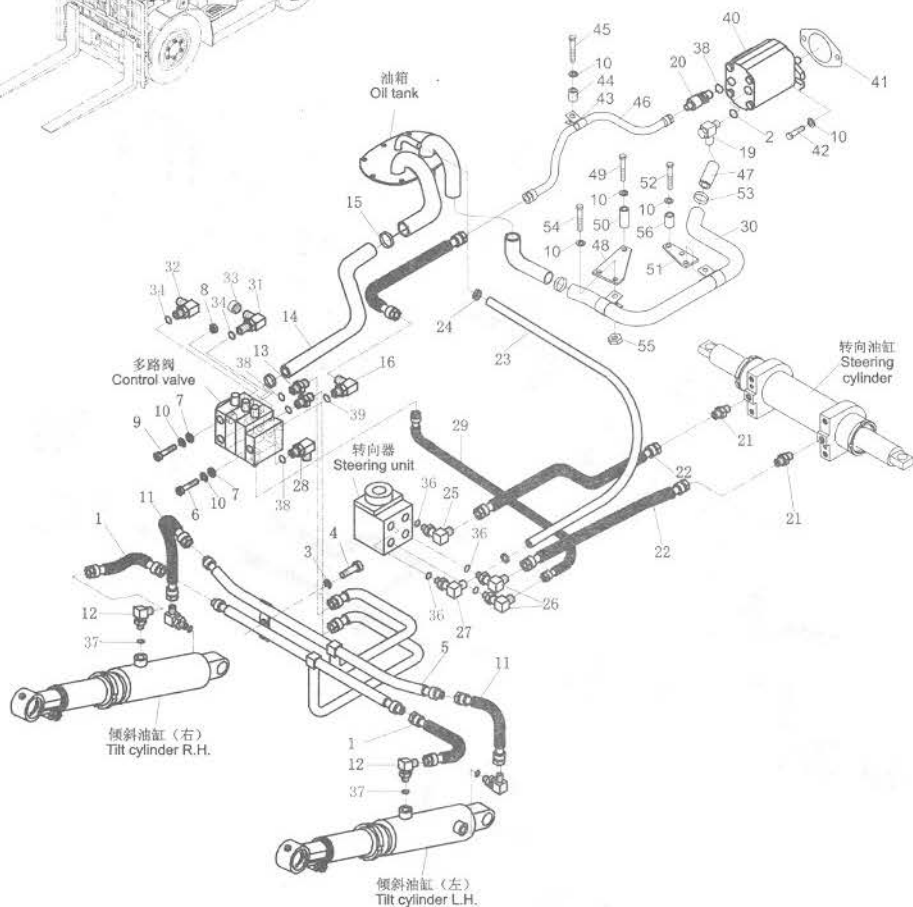
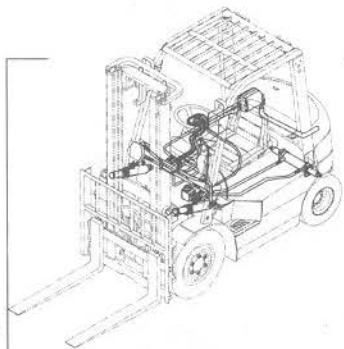
CPC, CPCD20, 25, 30-Ku1

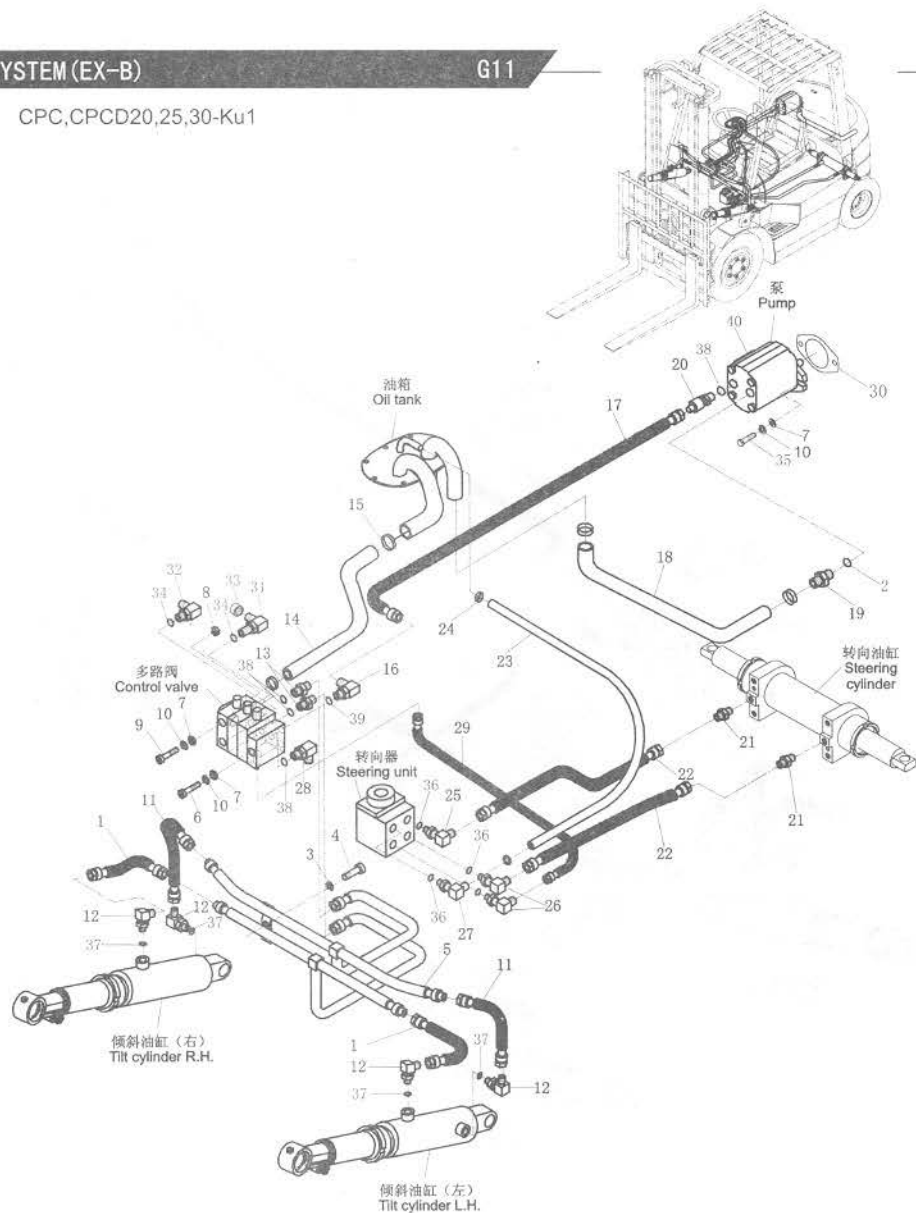

CPC, CPCD20, 25, 30-Ku1

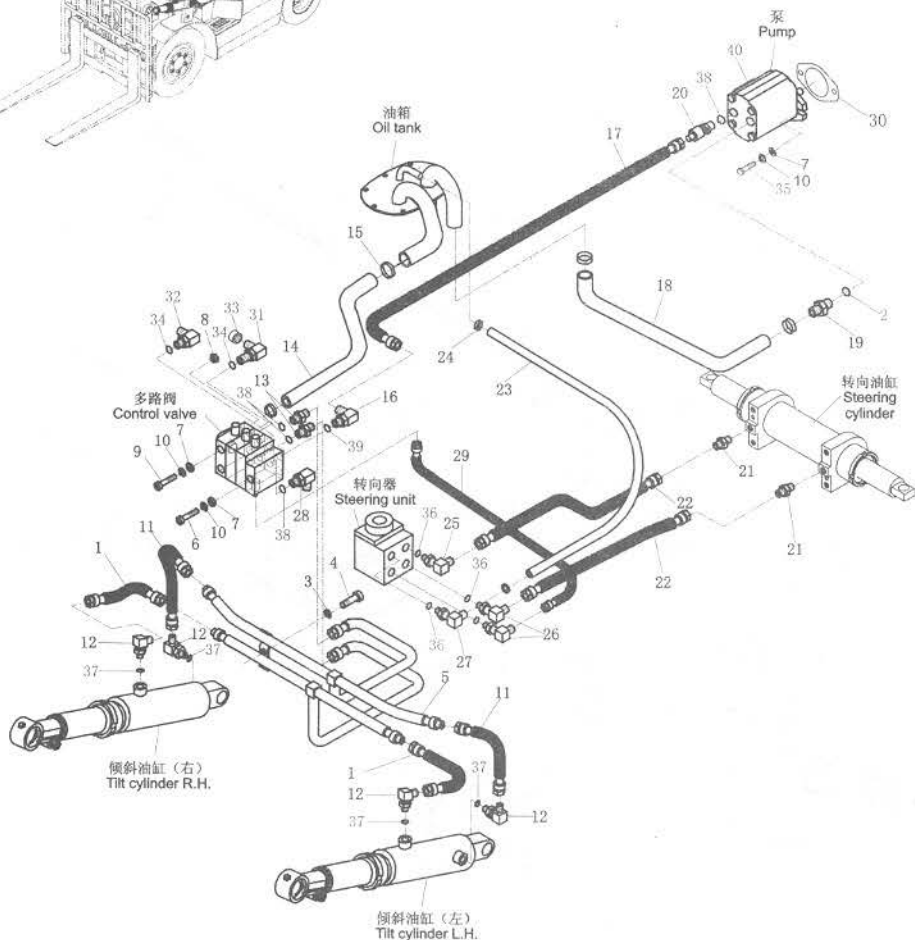
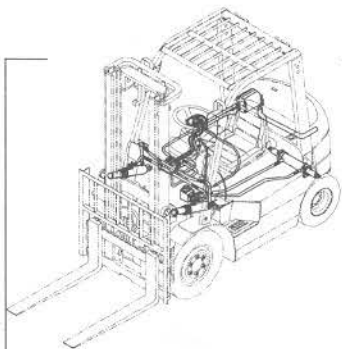

序号 Item No	图号 Part No	零部件名称 Description	件数 Q'ty	备注 Remark
26	JT6022-20051	Elbow(Inc.36) 直角接头(包括36)	2	
27	JT6022-22041	Elbow(Inc.36) 直角接头(包括36)	1	
28	JT6022-22011	Elbow(Inc.38) 直通接头(包括38)	1	
29	A12A7-60401	Hose H.P. 高压胶管	1	
30	23657-12001	Packing 垫	2	
31	JT6022-20061	Elbow(Inc.34) 直角接头(包括34)	1	三片阀Three-throw
			2	四片阀Four-throw
			3	五片阀Five-three
32	JT6022-20071	Elbow(Inc.34) 直角接头(包括34)	1	三片阀Three-throw
			2	四片阀Four-throw
			3	五片阀Five-three
33	22497-61010	Plug 堵头	2	三片阀Three-throw
			4	四片阀Four-throw
			6	五片阀Five-three
34	Z6004-01101	O-ring 0型密封圈11X1.9	2	三片阀Three-throw GB1235-76
			4	四片阀Three-throw GB1235-76
			6	五片阀Three-throw GB1235-76
35	B0430-10,110	Bolt 螺栓M10X1.25X110	2	GB5785-86
36	Z6003-02202	O-ring 0型密封圈22X2.4	4	GB1235-76
37	Z6003-01502	O-ring 0型密封圈15X2.4	4	GB1235-76
38	Z6004-02202	O-ring 0型密封圈22X2.4	4	GB1235-76
39	Z6003-02402	O-ring 0型密封圈24X2.4	1	GB1235-76
40	H14S7-10001	Gear pump 泵	1	21,2.5t
-	H2F97-10001	Gear pump 泵	1	3t

图114/FIG114

液压系统/HYDRAULIC SYSTEM (EX-A)

G12

序号 Item No	图号 Part No	零部件名称 Description	件数 Q'ty	备注 Remark
A	HRE2B97601 E2B97-60001	Hydraulic system 液压管路系统	1	2t
-	HRE2B97601 E2D97-60001	Hydraulic system 液压管路系统	1	2.5t
-	HRE2B97601 E2F97-60001	Hydraulic system 液压管路系统	1	3t
01	E24C7-60271	Hose H.P. 高压胶管总成	1	
02	Z6051-02804	O-ring O型密封圈28X3.55	2	GB1235-76
03	B5050-00006	Washer,lock 垫圈6	9	GB93-87
04	B0330-06025	Bolt 螺栓M6X25	2	GB5783-86
05	E24C7-60231	Steel pipe ass'y 倾斜缸钢管总成	1	
06	B0530-10025	Bolt 螺栓M10X1.25X25	1	GB5786-86
07	B5310-00010	Washer 垫圈10	10	GB97.1-85
08	B4223-00010	Nut 螺母M10X1.25	4	GB6171-86
09	B0330-10040	Bolt 螺栓M10X40	4	GB5783-86
10	B5050-00010	Washer,lock 垫圈10	10	GB93-87
11	Z7801-8a03614	Hose H.P. 高压胶管	2	
12	JT8022-96051	Elbow(Inc.37) 直角接头(包括37)	4	
13	JT6021-20021	Nipple(Inc.38) 直通接头(包括38)	2	
14	H24C7-60231	Hose 多路阀回油管	1	二至四片阀 Two to four-throw
-	H24C7-60241	Hose 多路阀回油管	1	五片阀Five-throw
15	Z4590-00045	Clip 双钢丝卡箍 \varnothing 45	8	
16	JT8022-34011	Elbow(Inc.36) 直角接头(包括36)	1	
17	Z7802-13117	Hose H.P. 高压胶管13 \square X1170	1	
18	H2B97-62004	Hose 吸油管	1	
19	JT7021-10011	Nipple(Inc.02) 直通接头(包括02)	1	
20	E24C7-60321	Elbow(Inc.38) 油泵接头(包括38)	1	
21	JT8025-96031	Nipple 直通接头体	2	
22	Z7801-08208	Hose H.P. 高压胶管	2	2t,2.5t
-	Z7801-08216	Hose H.P. 高压胶管	2	3t
23	Z7300-13160	Hose H.P. 低压胶管 \varnothing 13X1600	1	
24	Z4503-16025	Clip 喉箍16-25	2	
25	JT8022-96041	Elbow(Inc.36) 直角接头(包括36)	1	

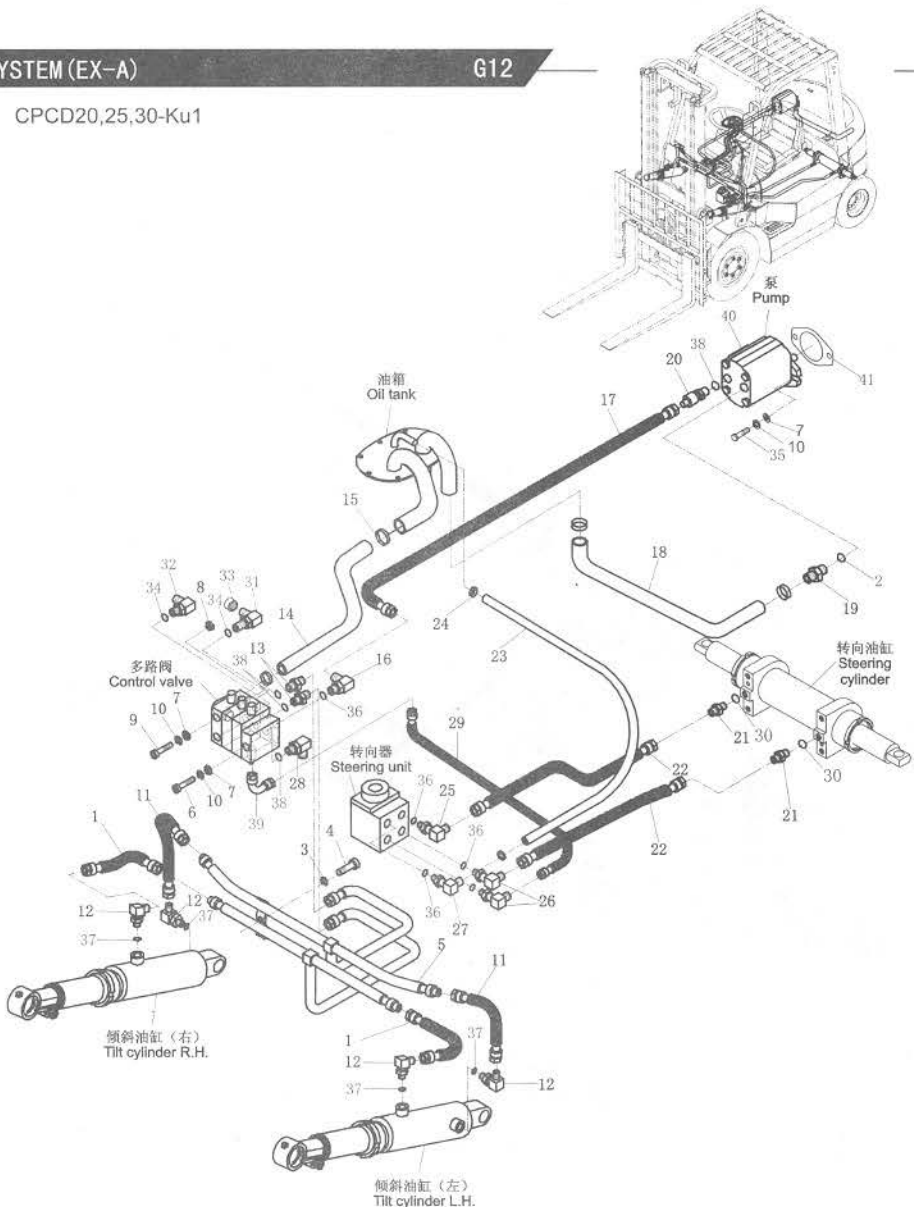

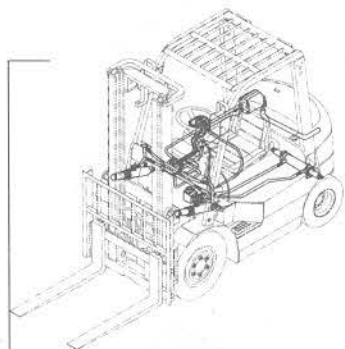

CPCD20,25,30-Ku1

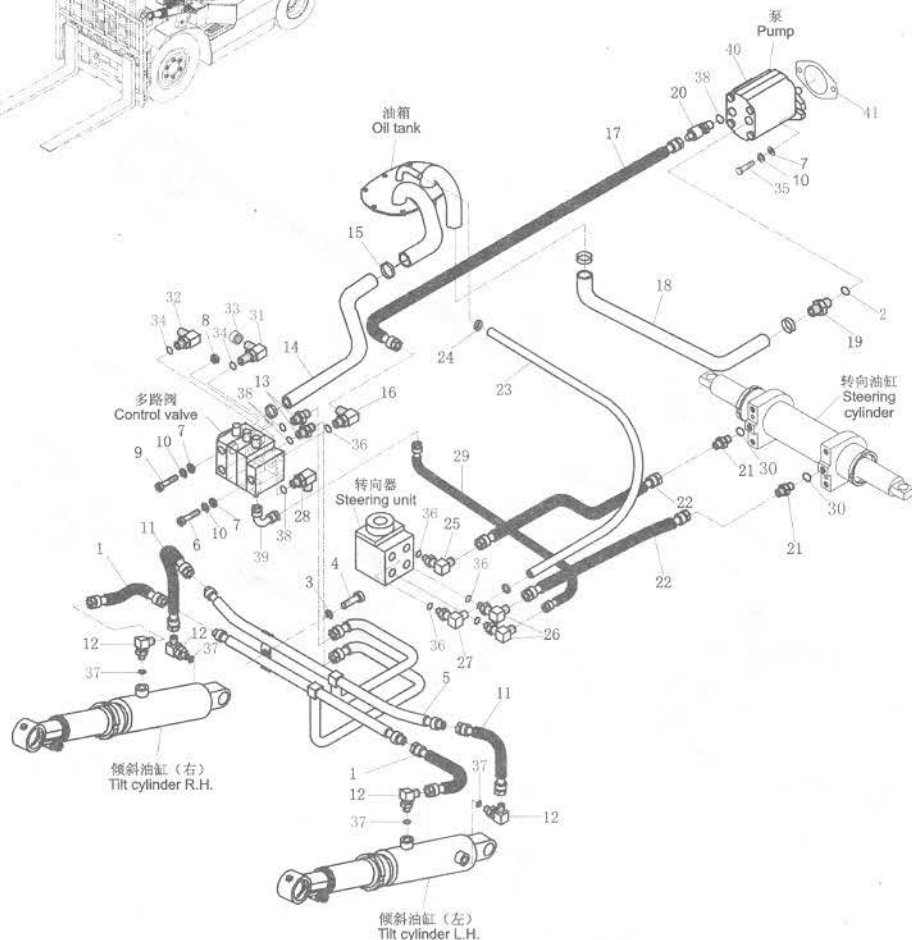

序号 Item No	图号 Part No	零部件名称 Description	件数 Q'ty	备注 Remark
26	JT8022-96031	Elbow(Inc.36) 直角接头(包括36)	2	
27	JT6022-22041	Elbow(Inc.36) 直角接头(包括36)	1	
28	JT8022-34031	Elbow(Inc.38) 直通接头(包括38)	1	
29	HRE22A7605 E22A7-60501	Hose H.P. 高压胶管	1	
30	Z6003-01802	O-ring 0型密封圈18X2.4	2	GB1235-76
31	JT6022-20061	Elbow(Inc.34) 直角接头(包括34)	1	三片阀Three-throw
			2	四片阀Four-throw
			3	五片阀Five-throw
32	JT6022-20071	Elbow(Inc.34) 直角接头(包括34)	1	三片阀Three-throw
			2	四片阀Four-throw
			3	五片阀Five-throw
33	22497-61010	Plug 堵头	2	三片阀Three-throw
			4	四片阀Four-throw
			6	五片阀Five-throw
34	Z6004-01101	O-ring 0型密封圈11X1.9	2	三片阀Three-throw GB1235-76
			4	四片阀Three-throw GB1235-76
			6	五片阀Three-throw GB1235-76
35	B0430-10110	Bolt 螺栓M10X1.25X110	2	GB5785-86
36	Z6003-02202	O-ring 0型密封圈22X2.4	5	GB1235-76
37	Z6003-01502	O-ring 0型密封圈15X2.4	4	GB1235-76
38	Z6004-02202	O-ring 0型密封圈22X2.4	4	GB1235-76
39	JT8022-96021	Elbow 直角接头	1	
40	H14S7-10001	Gear pump 泵	1	21,2.5t
-	H2F97-10001	Gear pump 泵	1	3t
41	23657-12001	Packing 垫	2	

图115/FIG115

变矩器油冷却系统/TOR-CON OIL COOLING SYSTEM

G13

序号 Item No	图号 Part No	零部件名称 Description	件数 Q'ty	备注 Remark
A	HRH25S7801 H24D7-80001	Tor-con oil cooling system 变矩器油冷却系统	1	CPQD20-35 CPCD20-35-Xs1
-	HRH25S7801 H25S7-80001	Tor-con oil cooling system 变矩器油冷却系统	1	其余柴油车 The rest of the diesel
-	H99Z7-80001	Tor-con oil cooling system 变矩器油冷却系统	1	CPQD20-35-D CPCD20-30-Ku1
01	Z4690-00018	Clip 双钢丝卡箍 \varnothing 18	4	除CPCD20-35-D CPCD20-30-Ku1外
-	Z4590-00022	Clip 双钢丝卡箍 \varnothing 22	4	CPCD20-35-D CPCD20-30-Ku1
02	HRH25S7802 H24D7-82001	Hose 油冷却胶管	1	CPQD20-35 CPCD20-35-Xs1
-	HRH25S7802 H25S7-82001	Hose 油冷却胶管	1	其余柴油车 The rest of the diesel
-	Z7300-13220	Hose 油管 \varnothing 13x2200	1	CPQD20-35-D CPCD20-30-Ku1
03	HRH25S7803 H24D7-82011	Hose 油冷却胶管	1	CPQD20-35 CPCD20-35-Xs1
-	HRH25S7803 H25S7-82011	Hose 油冷却胶管	1	其余柴油车 The rest of the diesel
-	Z7300-13190	Hose 油管 \varnothing 13x1900	1	CPCD20-35-D CPCD20-30-Ku1
04	A23F7-83001	Band 捆扎带ZD200x8	2	
05	JT6025-14011	Nipple 直通接头体	2	除CPCD20-35-D CPCD20-30-Ku1外
-	H99Z7-82001	Nipple 直通接头	2	CPQD20-35-D CPCD20-30-Ku1
06	Z6700-01427	Washer 组合垫圈14	2	J6982-77

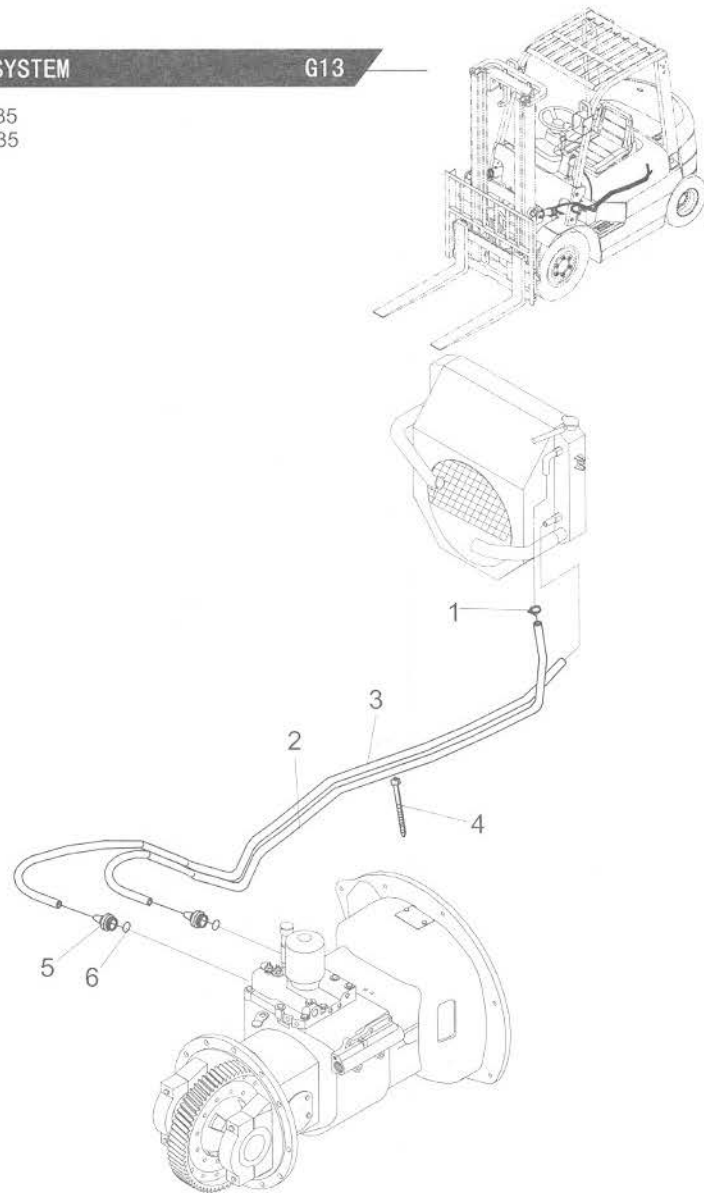
CPCD20,25,30,35
CPQD20,25,30,35

G

CPC, CPCD20, 25, 30
CPQ, CPQD20, 25, 30序号
Item
No图号
Part No零部件名称
Description件数
Q'ty备注
Remark

序号 Item No	图号 Part No	零部件名称 Description	件数 Q'ty	备注 Remark
A	HRE22A8601	Mast hydraulic system 门架管路系统	1	EX-A
-	HRD24C8601	Mast hydraulic system 门架管路系统	1	EX-B 2t, 2.5t
-	HRD24N8601	Mast hydraulic system 门架管路系统	1	EX-B 3t
01		Plastic hose 塑料回油管	1	见选用件表 See op. Parts
02	Z4500-10016	Clip 夹箍10-16	6	
03	24239-44311	Band 回油管管夹片	4	
04	JT6031-08011	Three way 升降缸回油接头	1	
05		Plastic hose 塑料回油管	1	见选用件表 See op. Parts
06	23659-40010G	Clip 卡箍	4	
07	Z7400-12112	Plastic hose 塑料回油管	4	
08	Z7802-13050GS	Hose H.P. 高压胶管 \varnothing 13X500	1	EX-A
-	Z9502-13050GS	Hose H.P. 高压胶管	1	EX-B
09	HRD20B8604 D20B8-60201	Flow regulator 限速阀	1	2t, 2.5t
-	HRD20B8604 D28B8-60201	Flow regulator 限速阀	1	3t
10	Z6700-02227	Washer 组合垫圈22	1	JB982-77
11	E20B8-60401	Three way (Inc.15) 三通接头(包括15)	1	EX-A
-	JT6031-22021	Three way (Inc.15) 三通接头(包括15)	1	EX-B
12	Z7802-13039	Hose H.P. 高压胶管	1	EX-A
-	Z9502-13039	Hose H.P. 高压胶管	1	EX-B
13	E22A8-60211	Valve, check (Inc.15) 切断阀(包括15)	1	EX-A
-	H22A8-60211	Valve, check (Inc.15) 切断阀(包括15)	1	EX-B
14	E20B8-60201	Connector 过渡接头	1	EX-A
15	Z6004-02202	O-ring 0型密封圈22X2.4	2	GB1235-76

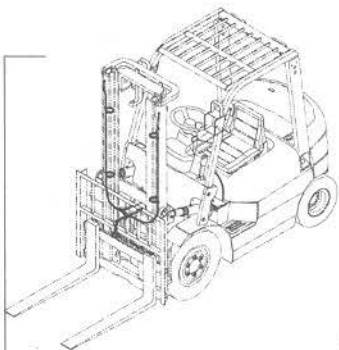
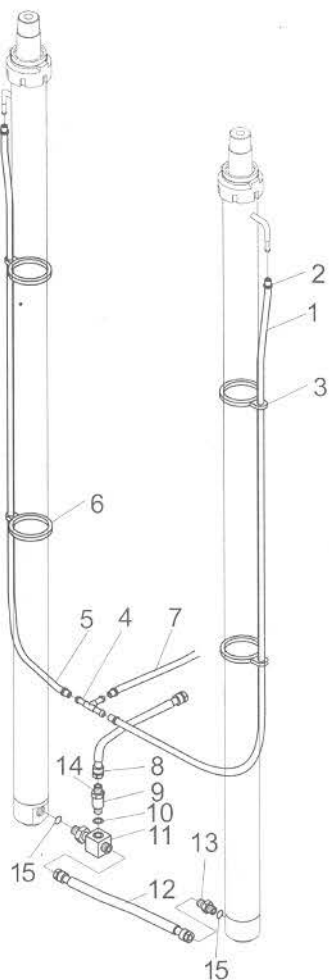

管路系统选用件 Mast Piping Optional Parts

起升高度 LIFTING HEIGHT	件5塑料回油管长度 PLASTIC HOSE		件1塑料回油管长度 PLASTIC HOSE		备注 REMARK
	图号 PART NO	长度 LENGTH	图号 PART NO	长度 LENGTH	
M200	Z7400-12085	850	Z7400-12100	1000	
250	-12110	1100	-12120	1200	
270	-12120	1200	-12130	1300	
300	-12135	1350	-12140	1400	标准(STD)
330	-12150	1500	-12160	1600	
350	-12160	1600	-12170	1700	
370	-12170	1700	-12180	1800	
380	-12175	1750	-12185	1850	
400	-12190	1900	-12200	2000	
425	-12200	2000	-12210	2100	
450	-12215	2150	-12230	2300	
475	-12230	2300	-12240	2400	
500	-12240	2400	-12250	2500	
550	-12270	2700	-12280	2800	
600	-12295	2950	-12310	3100	

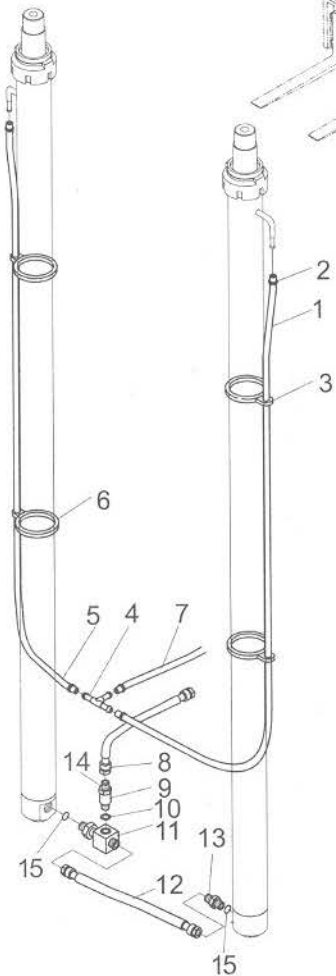
CPC,CPCD20,25,30
CPQ,CPQD20,25,30

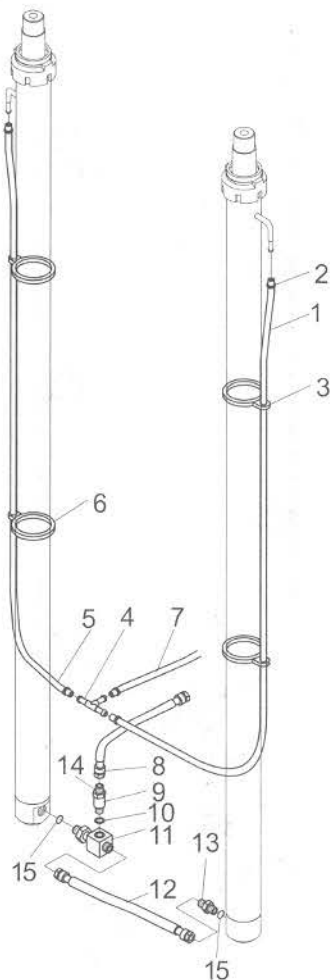
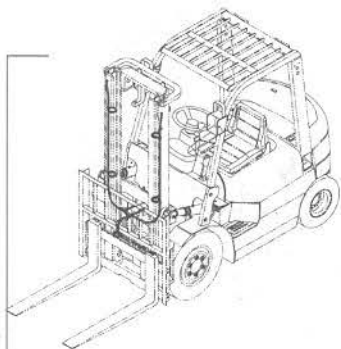

CPC, CPCD 35
CPQ, CPQD 35

序号 Item No	图号 Part No	零部件名称 Description	件数 Q'ty	备注 Remark
A	HRD30A8602	Mast hydraulic system 门架管路系统	1	EX-A
-	HRD30A8601	Mast hydraulic system 门架管路系统	1	EX-B
01	HRD20B8602	Plastic hose 塑料回油管	1	见选用件表 See op. Parts
02	Z4500-10016	Clip 夹箍10-16	6	
03	24239-44311	Band 回油管管夹片	4	
04	JT6031-08011	Three way 升降缸回油接头	1	
05	HRD20B8603	Plastic hose 塑料回油管	1	见选用件表 See op. Parts
06	23659-40010G	Clip 卡箍	4	
07	Z7400-14112	Plastic hose 塑料回油管	4	EX-A
-	Z7400-12112	Plastic hose 塑料回油管	4	EX-B
08	Z7802-13050GS	Hose H.P. 高压胶管	1	EX-A
-	D20B8-62032	Hose H.P. 高压胶管	1	EX-B
09	HRD20B8604 D28B8-60201	Flow regulator 限速阀	1	
10	Z6700-02227	Washer 组合垫圈	22	JB982-77
11	D30A8-60271	Three way (Inc.15) 三通接头(包括15)	1	EX-A
-	D30A8-60201	Three way (Inc.15) 三通接头(包括15)	1	EX-B
12	Z7802-13037	Hose H.P. 高压胶管	1	EX-A
-	Z7212-13036	Hose H.P. 高压胶管	1	EX-B
13	E40B8-60151	Through type connector (Inc.15) 直通接头	1	EX-A
-	A40B7-60151	Through type connector (Inc.15) 直通接头	1	EX-B
14	E20B8-60201	Connector 过渡接头	1	EX-A
15	Z6003-03004	O-ring 0型密封圈30X3.5	2	GB1235-76

管路系统选用件 Mast Piping Optional Parts

起升高度 IFTING HEIGHT	件5塑料回油管长度 PLASTIC HOSE		件1塑料回油管长度 PLASTIC HOSE		备注 REMARK
	图号 PART NO HRD20B8602	长度 LENGTH	图号 PART NO HRD20B8603	长度 LENGTH	
M200	Z7400-12085	850	Z7400-12120	1200	
225	-12095	950	-12130	1300	
250	-12110	1100	-12140	1400	
270	-12120	1200	-12150	1500	
275	-12120	1200	-12150	1500	
300	-12125	1250	-12175	1750	标准(STD)
325	-12135	1350	-12190	1900	
330	-12140	1400	-12195	1950	
350	-12160	1600	-12190	1900	
366	-12160	1600	-12215	2150	
370	-12160	1600	-12215	2150	
375	-12160	1600	-12215	2150	
400	-12180	1800	-12235	2350	
425	-12190	1900	-12245	2450	
450	-12205	2050	-12260	2600	
475	-12215	2150	-12270	2700	
500	-12230	2300	-12285	2850	
550	-12260	2600	-12315	3150	
600	-12285	2850	-12340	3400	

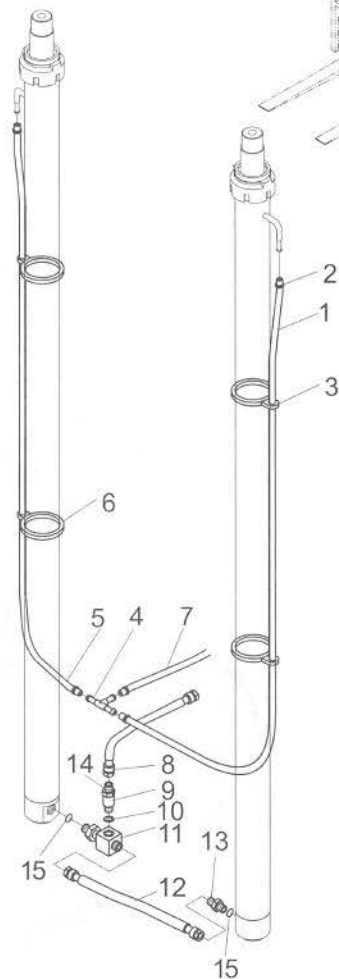
CPC, CPCD35
CPQ, CPQD35

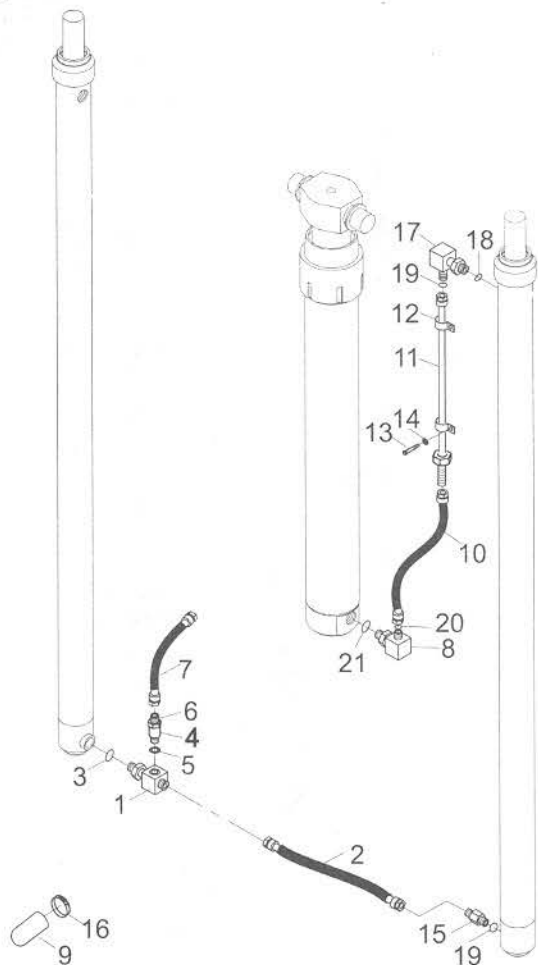
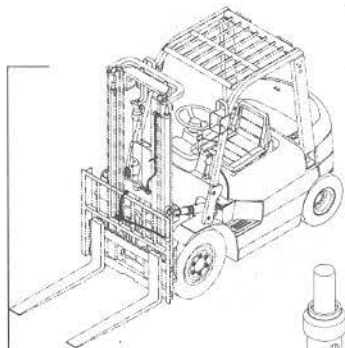

CPC, CPCD20, 25, 30
CPQ, CPQD20, 25, 30

序号 Item No	图号 Part No	零部件名称 Description	件数 Qty	备注 Remark
A	HRD20L0603	Mast pipe-line system	1	2t, 2.5t, EX-B
-	HRE20L0603	Mast pipe-line system	1	2t, 2.5t, EX-A
-	HRD28L0603	Mast pipe-line system	1	3t, EX-B
-	HRE28L0603	Mast pipe-line system	1	3t, EX-A
01	JT6031-22021	Three-way (Inc.03)	1	EX-B
-	E20B8-60401	Three-way (Inc.03)	1	EX-A
02	Z9502-13039	Hose, H.P.	1	EX-B
-	Z7802-13039	Hose, H.P.	1	EX-A
03	Z6004-02202	O-ring seal	4	GB1235-76
04	HRD20B8604	Flow regulator	1	2t, 2.5t
-	D20B8-60201	Flow regulator	1	3t
-	HRD20B8604	Flow regulator	1	3t
-	D28B8-60201	Flow regulator	1	3t
05	Z6700-02227	Washer	1	JB982-77
06	E20B8-60201	Connector	1	EX-A
07	Z9502-13050GS	Hose, H.P.	1	EX-B
-	Z7802-13065GS	Hose, H.P.	1	EX-A
08	JT6022-27071	Elbow (Inc.20, 21)	1	EX-B
-	JT8022-34021	Elbow (Inc.21)	1	EX-A
09	23650-89901	Sleeve	1	封头套管
10	REF339337G	Hose	1	2t, 2.5t, EX-B
-		Hose, H.P.	1	2t, 2.5t, EX-A
-	REF339337G	Hose	1	3t, EX-B
-	Z7802-13054	Hose, H.P.	1	3t, EX-A
11	REF208232	Steel pipe ass'y	1	2t, 2.5t, EX-B
-	HRD26D8605	Steel pipe ass'y	1	2t, 2.5t, EX-A
-	REF208232	Steel pipe ass'y	1	3t, EX-B
-	HRE28L0605	Steel pipe ass'y	1	3t, EX-A
12	23670-62201	Clip	2	管夹
13	B0330-06016	Bolt	2	螺栓M6X16
14	B5050-00006	Washer, lock	2	垫圈6
15	JT6021-22101	Through type connector (Inc.19)	1	直通接头

图118/FIG118

门架管路系统(二级全自由)/HYDRAULIC SYSTEM MAST (FULL FREE 2-STAGE MAST ZM)

G16

序号 Item No	图号 Part No	零部件名称 Description	件数 Q'ty	备注 Remark
-	D26D0-90751	Through type connector (Inc.19)直通接头	1	EX-A
16	Z4590-00019	Clip 双钢丝卡箍 \varnothing 19	1	
17	JT6022-27021	Elbow (Inc.18,19) 直角接头	1	
18	Z6004-02402	O-ring seal 0型密封圈24X2.4	1	GB1235-76
19	Z6003-02202	O-ring seal 0型密封圈22X2.4	2	GB1235-76
20	Z6003-01602	O-ring seal 0型密封圈16X2.4	1	GB1235-76
21	Z6004-03004	O-ring seal 0型密封圈30X3.5	1	GB1235-76

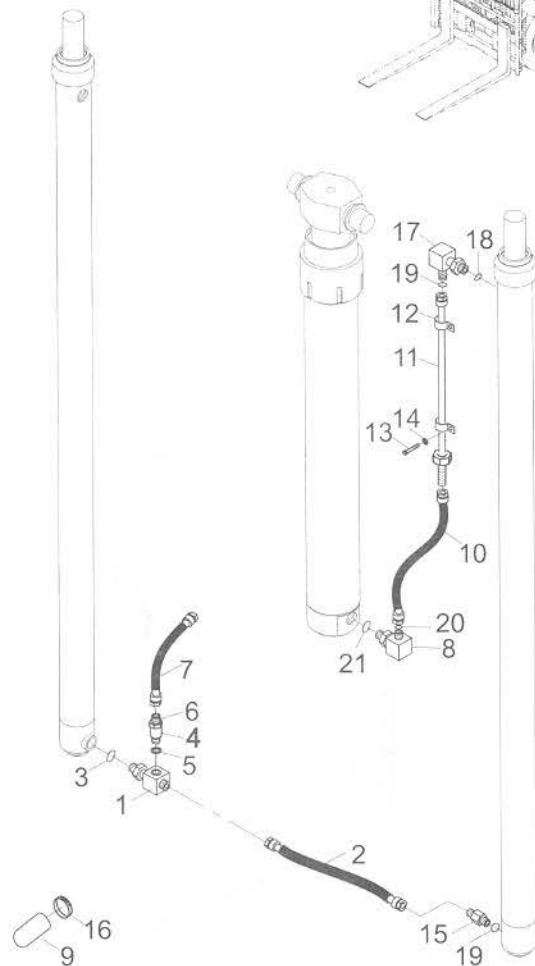
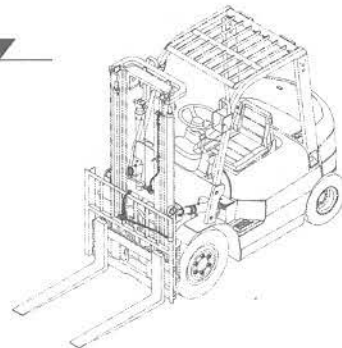
CPC, CPCD20, 25, 30
CPQ, CPQD20, 25, 30

G

CPC,CPCD20,25,30
CPQ,CPQD20,25,30

门架管路选用件 (EX-B) (二级全自由门架)
MAST PIPE-LINE SYSTEM (EX-B) (FULL FREE 2-STAGE MAST)

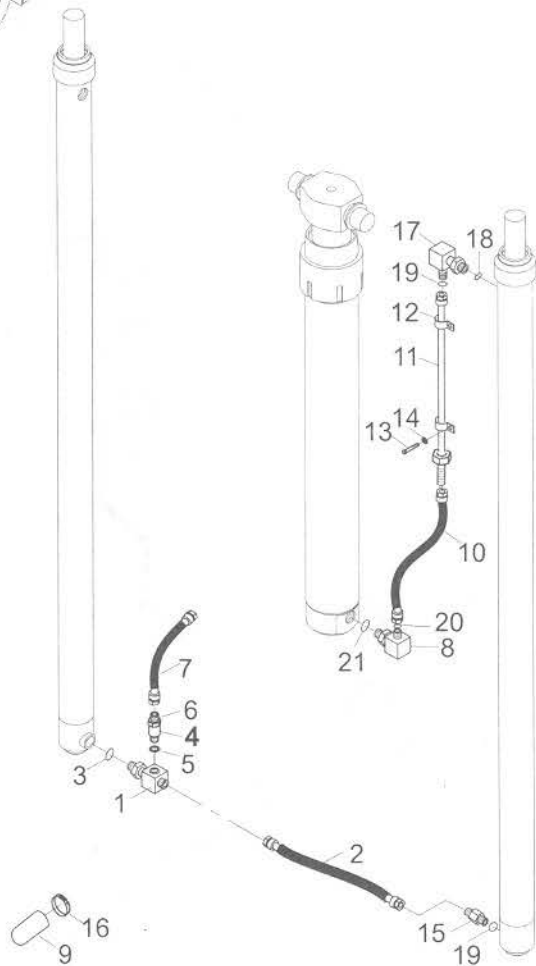
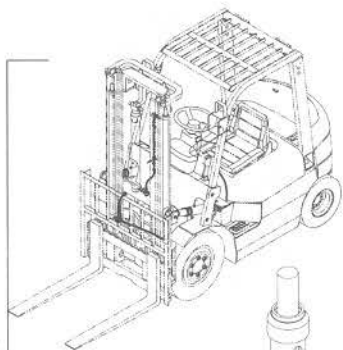

起升高度 IFTING HEIGHT	门架管路系统 HYDRAULIC SYSTEM	件10高压胶管 HOSE H. P.		钢管 HOSE		备注 REMARK
		2t, 2.5t	3t	2t, 2.5t	3t	
ZM	23657	Z7002	Z7002	23657	23657	
200	-60111	-13057GS	-13075GS	-66301a	-66261b	
225	-60121	-13042GS	-13042GS	-66201	-66201	
250	-60131	-13055GS	-13055GS	-66201	-66201	
270	-60141	-13040GS	-13040GS	-66211	-66211	
275	-60151	-13042GS	-13042GS	-66211	-66211	
300	-60101	-13055GS	-13055GS	-66211	-66211	标准 STD
325	-60161	-13052GS	-13052GS	-66271	-66271	
330	-60171	-13055GS	-13055GS	-66271	-66271	
350	-60181	-13042GS	-13042GS	-66311a	-66221	
366	-60191	-13050GS	-13050GS	-66221	-66221	
370	-60211	-13052GS	-13052GS	-66221	-66311a	
375	-60221	-13055GS	-13055GS	-66221	-66221	
400	-60231	-13055GS	-13055GS	-66281	-66281	
425	-60241	-13042GS	-13042GS	-66231	-66231	
450	-60251	-13055GS	-13055GS	-66231	-66231	
475	-60261	-13042GS	-13042GS	-66241	-66241	
500	-60271	-13055GS	-13055GS	-66241	-66241	
550	-60281	-13055GS	-13055GS	-66291	-66291	
600	-60291	-13055GS	-13055GS	-66251	-66251	

门架管路选用件 (EX-A) (二级全自由门架)
 MAST PIPE-LINE SYSTEM (EX-A) (FULL FREE 2-STAGE MAST)

起升高度 IFTING HEIGHT	门架管路系统 HYDRAULIC SYSTEM		件10高压胶管 HOSE H.P.		钢 管 HOSE		备注 REMARK
	2t, 2.5t	3t	2t, 2.5t	2t, 2.5t	3t		
ZM 200	E20L0 -60501	E28L0 -60501	Z7802 -13040	D26D0 -60271	E28L0 -62011		
225	-60511	-60511	-13042	-60211	-62021		
250	-60521	-60521	-13042	-60211	-62031		
270	-60531	-60531	-13055	-60221	-62041		
275	-60541	-60541	-13042	-60221	-62051		
300	-60551	-60551	-13042	-60221	-62061	标准 (STD)	
325	-60561	-60561	-13052	-60281	-62071		
330	-60571	-60571	-13055	-60281	-62081		
350	-60581	-60581	-13042	-60231	-62091		
366	-60591	-60591	-13050	-60231	-62101		
370	-60601	-60601	-13052	-60231	-62111		
375	-60611	-60611	-13055	-60231	-62121		
400	-60621	-60621	-13055	-60291	-62131		
425	-60631	-60631	-13042	-60241	-62141		
450	-60641	-60641	-13055	-60241	-62151		
475	-60651	-60651	-13042	-60251	-62161		
500	-60661	-60661	-13055	-60251	-62171		
550	-60671	-60671	-13055	-60301	-62181		
600	-60681	-60681	-13055	-60261	-62191		

CPC, CPCD20, 25, 30
 CPQ, CPQD20, 25, 30

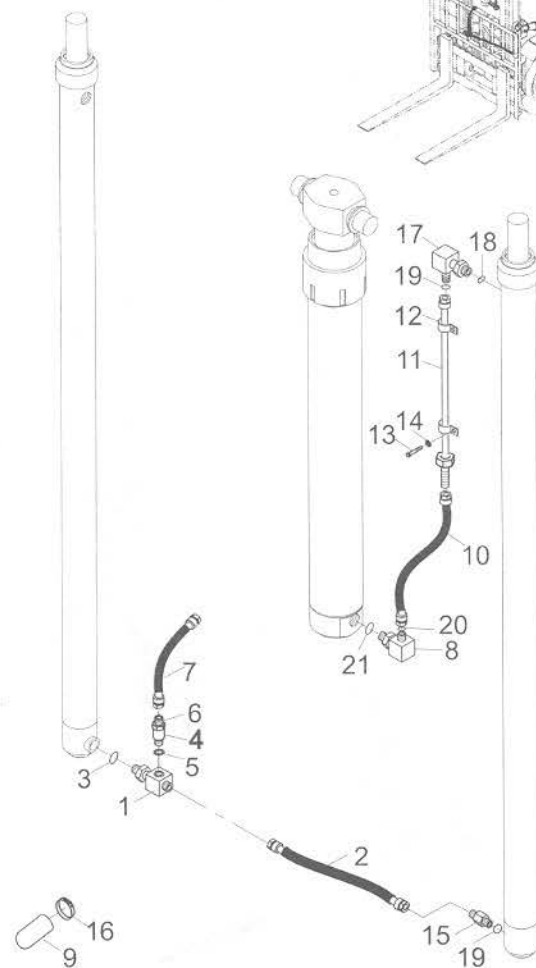

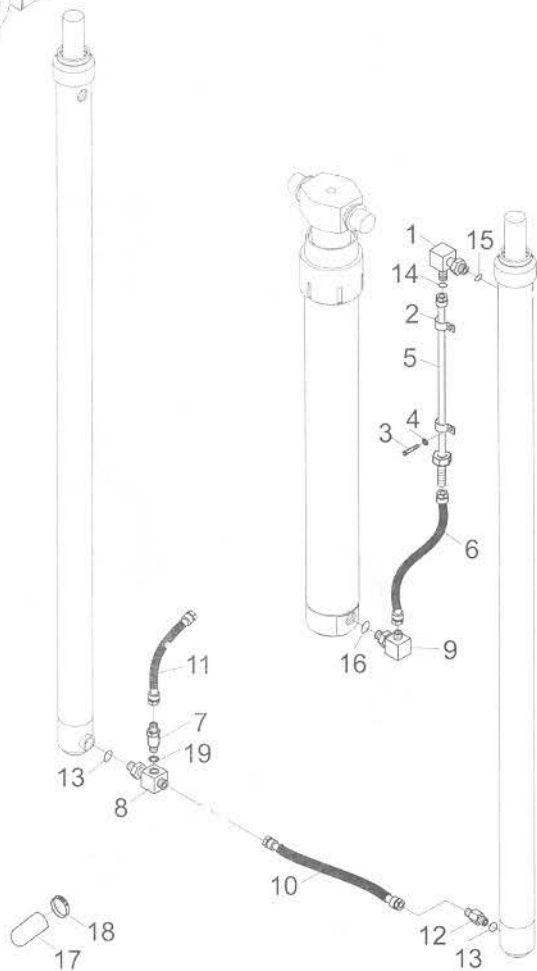
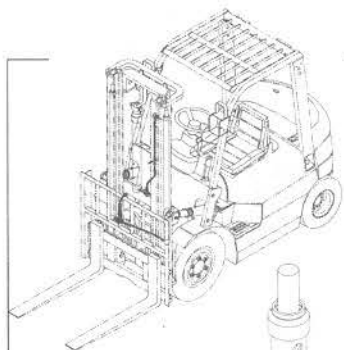
CPC, CPCD35
CPQ, CPQD35

序号 Item No	图号 Part No	零部件名称 Description	件数 Q'ty	备注 Remark
A	HRD30K0608	Mast hydraulic system 门架管路系统	1	见选用件表 See Op. Parts
01	JT6022-27021	Elbow (Inc.14,15) 直角接头(包含14,15)	5	
02	D30K0-62811	Clip 管夹	1	
03	B5050-00006	Bolt 螺栓M6X16	5	GB5781-86
04	B0110-06016	Washer 垫圈6	1	GB93-87
05	REF208232	Steel tube ass'y 钢管总成	1	见选用件表 See Op. Parts
06	Z9502-1300GS	Hose H.P. 高压胶管	1	见选用件表 See Op. Parts
07	HRD20B8604 D28B8-60201	Flow regulator 限速阀	1	
08	JT6031-22021	Three-way(Inc.13) 三通接头(包含13)	1	
09	JT6022-27081	Elbow(Inc.16) 直角接头(包含16)	1	
10	Z9502-13060	Hose 胶管接头13HX360	1	
11	Z7002-13050GS	Hose 胶管接头13HX500	1	JB1885-77
12	H22A8-60211	Valve,check(Inc.13) 切断阀(包含13)	1	
13	Z6004-02202	O-ring 0型密封圈22X2.4	2	GB1235-76
14	Z6003-02202	O-ring 0型密封圈22X2.4	1	GB1235-76
15	Z6004-02402	O-ring 0型密封圈24X2.4	1	GB1235-76
16	Z6004-03004	O-ring 0型密封圈30X3.5	1	GB1235-76
17	Z3650-89901	Hose 封头套管	1	
18	Z4590-00019	Clip 双钢丝夹箍	2	
19	Z6700-02227	Washer 组合垫圈22	2	JB982-77

管路系统选用件
MAST PIPING OPTIONAL PARTS

CPC, CPCD35
CPQ, CPQD35

起升高度 LIFTING HEIGHT	门架管路系统 MAST HYDRAULIC SYSTEM	件6高压胶管 HOSE H. P.	件5钢管总成 STEEL TUBE ASS'Y	备注 REMARK
ZM200	HRD30K0608 D30K0-61111	Z9502-13064GS	REF208232 23657-66301A	
250	-61121	-13064GS	-66201	
270	-61131	-13039GS	-66211	
300	-61101	-13064GS	-66211	标准 (STD)
330	-61141	-13064GS	-66271	
350	-61151	-13064GS	-66271	
370	-61161	-13064GS	-66311a	
400	-61171	-13064GS	-66281	
425	-61181	-13064GS	-66281	
450	-61191	-13064GS	-66231	
475	-61201	-13064GS	-66231	
500	-61211	-13064GS	-66241	
550	-61221	-13064GS		
600	-61231	-13064GS		

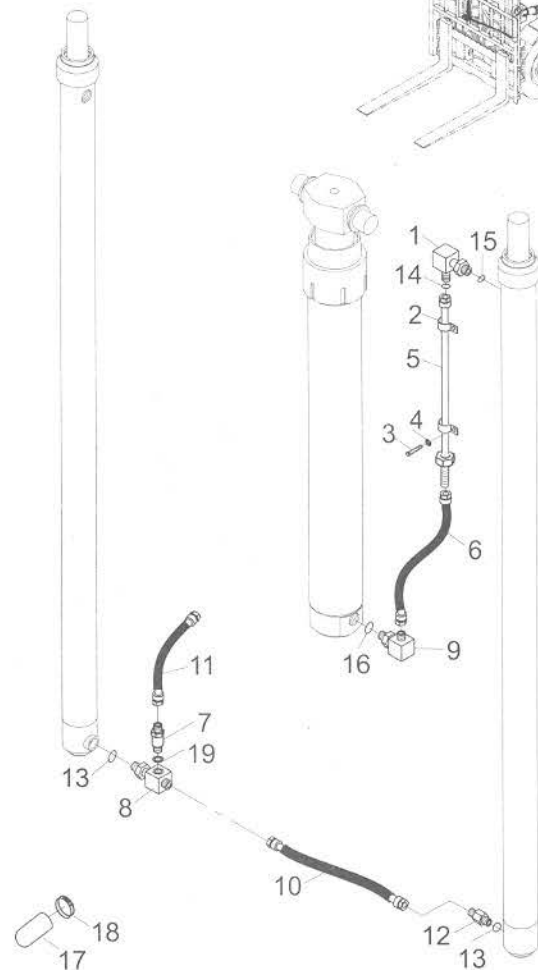

货叉选用件表Fork optional parts

型式 MODEL			长度	货叉总成代号 PART NO.			备注
2t, 2.5t	3t	3.5t	LENGTH	2t, 2.5t	3t	3.5t	REMARK
LF92-14A			920	D20B8 -10001			2t STD
		LF100-32A	1000			A32A8 -10001	
LF107-14A	LF107-14J	LF107-32A	1070	-10011	D28B8 -10001	-10011	2.5t,3t, 3.5t STD
		LF110-32A	1100			-10021	
		LF120-32A	1200			-10031	
LF122-14A	LF122-14J	LF122-32A	1220	-10021	-10011	-10041	
LF137-14A	LF137-14J	LF137-32A	1370	-10031	-10021	-10051	
LF152-14A	LF152-14J	LF152-32A	1520	-10041	-10031	-10061	
LF167-14A	LF167-14J	LF167-32A	1670	-10051	-10041	-10071	
LF182-14A	LF182-14J	LF182-32A	1820	-10061	-10051	-10081	
	LF197-14J	LF197-32A	1970		-10061	-10091	
	LF212-14J	LF212-32A	2120		-10071	-10101	
LF90-14A			900	-10071			
LF100-14A	LF100-14J		1000	-10081	-10081		
LF110-14A	LF110-14J		1100	-10091	-10091		
LF120-14A	LF120-14J		1200	-10101	-10111		
LF130-14A	LF130-14J		1300	-10111	-10121		
LF140-14A	LF140-14J		1400	-10121	-10131		
LF150-14A	LF150-14J		1500	-10131	-10141		
LF160-14A	LF160-14J		1600	-10141	-10151		
LF170-14A	LF170-14J		1700	-10151	-10161		
LF180-14A	LF180-14J		1800	-10161	-10171		
LF190-14A	LF190-14J		1900	-10171	-10181		
LF200-14A	LF200-14J		2000	-10181	-10191		

CPQ,CPQD20,25,30,35
CPC,CPCD20,25,30,35

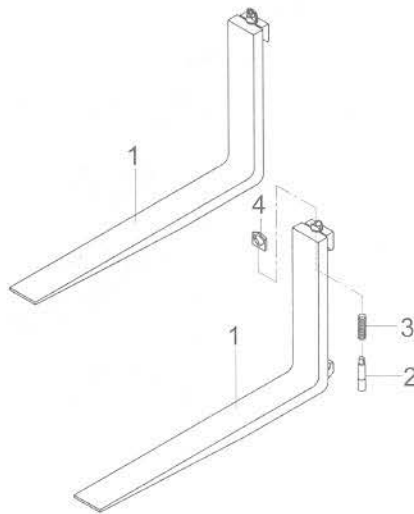
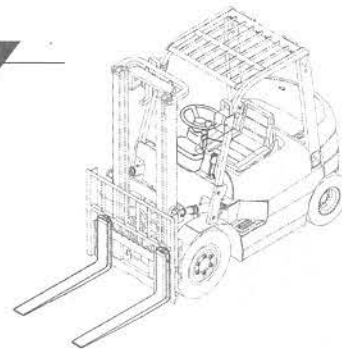

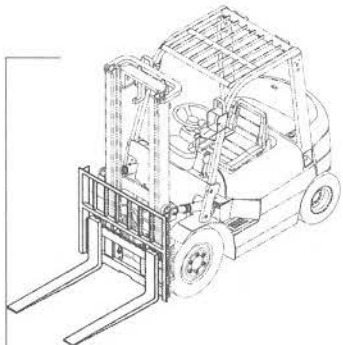

H2

货叉架(基本)/LIFT BRACKET (NORMAL MAST M)

图121/FIG121

CPQ,CPQD20,25,30
CPC,PCD20,25,30

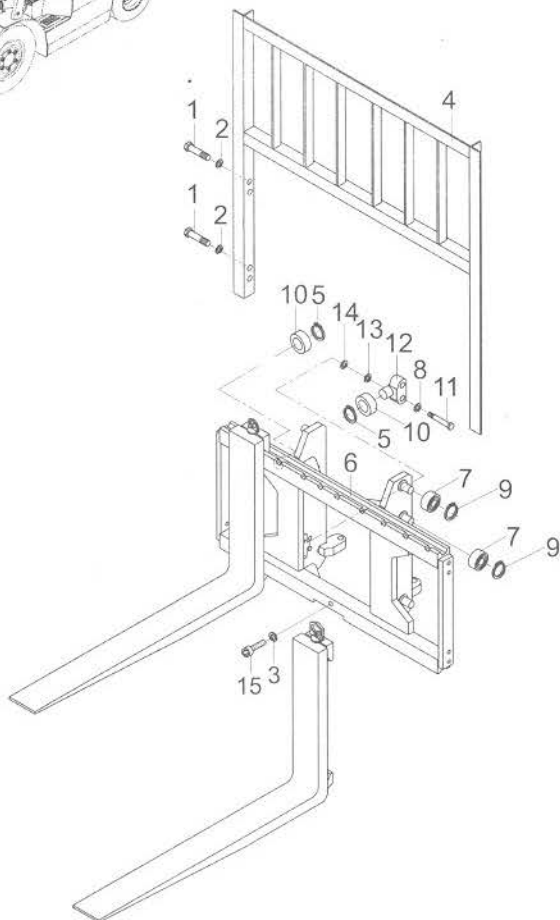

序号 Item No	图号 Part No	零部件名称 Description	件数 Q'ty	备注 Remark
01	B0330-14030	Bolt	螺栓M14X30	8 GB5783-86
02	B5050-00014	Washer,lock	垫圈14	8 GB93-87
03	B5050-00012	Washer,lock	垫圈12	1 GB93-87
04	HRD20B8206 D20B8-20701	Backrest	挡货架	1 2t,2.5t
-	D28B8-20301	Backrest	挡货架	1 3t
05	B6152-00025	Snap ring	挡圈25	4 GB894.1-86
06	D24C8-20201	Lift bracket	货叉架总成	1 2t,2.5t
-	D24N8-20201	Lift bracket	货叉架总成	1 3t
07	980811N-00	End roller	主滚轮 $\varnothing 119.2 \times 55-34$	6
08	B5050-00016	Washer,lock	垫圈16	4 GB93-87
09	B6152-00055	Snap ring	挡圈55	6 GB894.1-86
10	22578-22401	Spacing roller	限位滚轮	4
11	B0332-16045	Bolt	螺栓M16X45	4 GB5783-86
12	22679-43761	Shaft,spacing roller	限位滚轮轴	2
13	22679-43831	Washer	垫圈	AR
14	23917-42191	Washer	垫圈	AR
15	B8030-12020	Screw	螺钉M12X20	1 GB70-85

H

CPC, CPCD20,25
CPQ, CPQD20,25

序号 Item No	图号 Part No	零部件名称 Description	件数 Q'ty	备注 Remark
01	23917-42191	Washer	垫圈 12	
02	B5050-00014	Washer,lock	垫圈 14	8 GB93-87
03	B0330-14030	Bolt	螺栓 M14X30	8 GB5783-86
04	HRD20B8206 D20B8-20701	Backrest	挡货架	1
05	B6150-00025	Snap ring	挡圈 25	4 GB894.1-86
06	D20L0-60201	Lift bracket	货叉架	1
07	980811N-00	End roller	主滚轮 $\varnothing 119.2 \times 55-34$	6
08	B5050-00016	Washer,lock	垫圈 16	4 GB93-87
09	B6150-00055	Snap ring	挡圈 55	6 GB894.1-86
10	22578-22401	Spacing roller	限位滚轮	4
11	B0330-16040	Bolt	螺栓 M16X40	4 GB5783-86
12	22679-43761	Shaft,spacing roller	限位滚轮轴	2
13	22679-43831	Washer	垫圈	32



图124/FIG124

货叉架(二级全自由)/LIFT BRACKET (FULL FREE 2-STAGE MAST ZM)

H5

序号 Item No	图号 Part No	零部件名称 Description	件数 Q'ty	备注 Remark
01	B0330-16040	Bolt 螺栓M16X40	4	GB5783-86
02	B5050-00016	Washer,lock 垫圈16	4	GB93-87
03	B5050-00014	Washer,lock 垫圈14	8	GB93-87
04	B0330-14030	Bolt 螺栓M14X30	8	GB5783-86
05	HRD30A8203 D28B8-20301	Backrest 挡货架	1	
06	D28L0-60201	Lift bracket 货叉架	1	
07	B6150-00030	Snap ring 挡圈30	2	GB894.1-86
08	22198-22341	End roller 滚轮 $\varnothing 91.5$	2	
09	980811N-00	End roller 滚轮 $\varnothing 119.2 \times 55-34$	6	
10	B6150-00055	Snap ring 挡圈55	6	GB894.1-86
11	24609-42131	Shaft 侧滚轮轴	2	
12	24609-42151	Shim 调整垫片1	6	
13	24609-42161	Shim 调整垫片0.2	8	
14	20037-42191	Shim 垫块3	4	

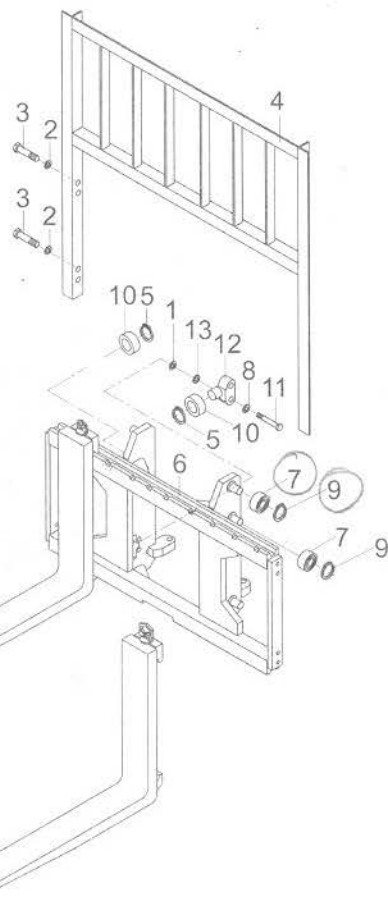
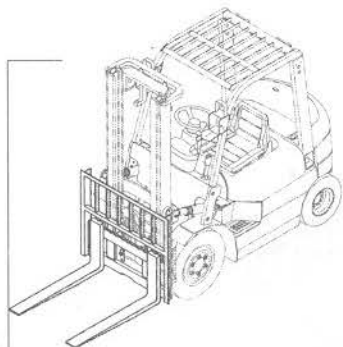
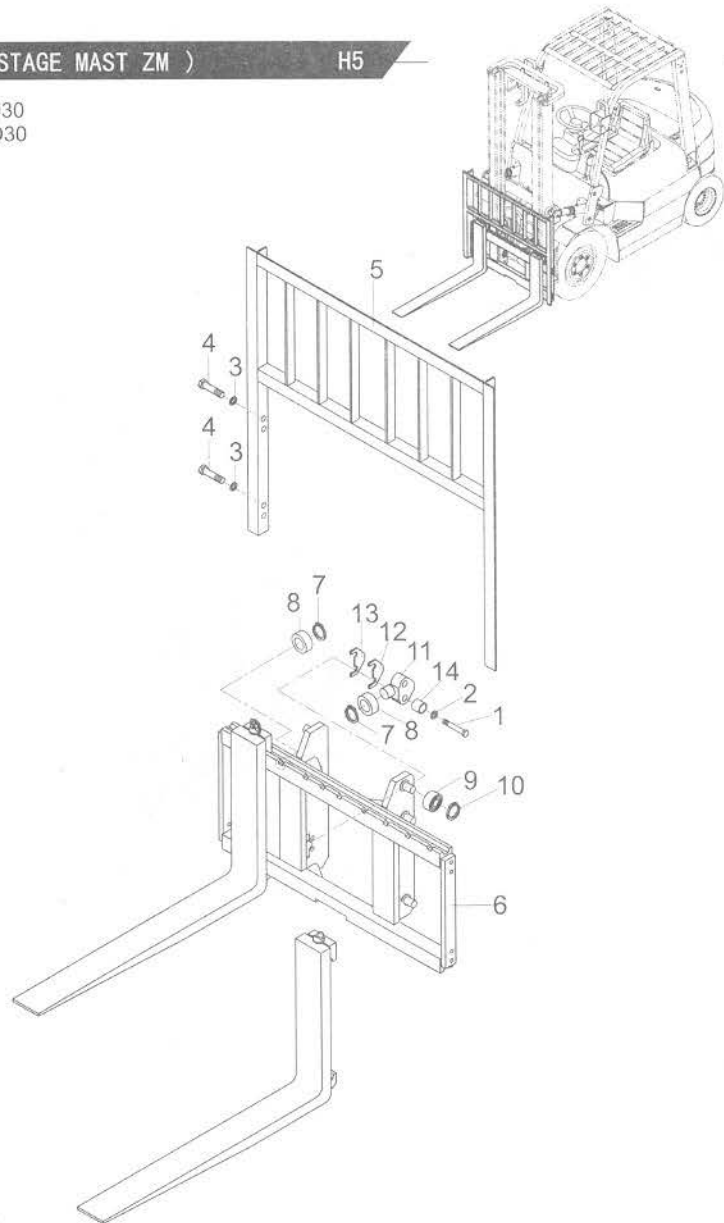
CPC, CPCD30
CPQ, CPQD30

H

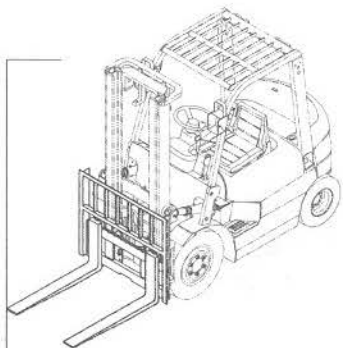

H6

货叉架(二级全自由)/LIFT BRACKET (FULL FREE 2-STAGE MAST ZM)

图125/FIG125

CPC, CPCD35
CPQ, CPQD35

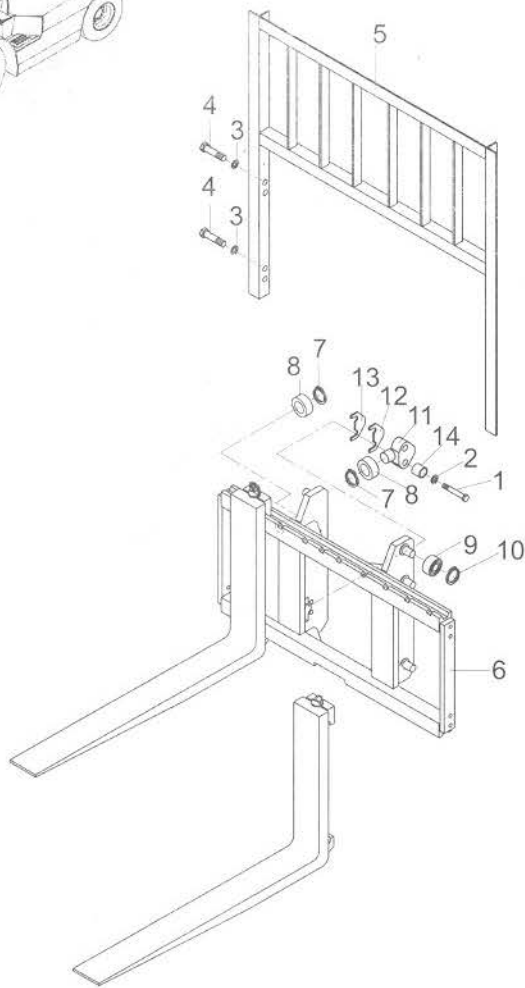

序号 Item No	图号 Part No	零部件名称 Description	件数 Q'ty	备注 Remark
01	B0430-16065	Bolt 螺栓M16X1.5X65	4	GB5785-86
02	B5050-00016	Washer 垫圈16	4	GB93-87
03	B5050-00014	Washer 垫圈14	8	GB93-87
04	B0330-14030	Bolt 螺栓M14X30	8	GB5783-86
05	HRD30A8203 D28B8-20301	Backrest 挡货架	1	标准 STD
-	HRD30A8203 D30A8-20222	Backrest 挡货架	1	选用 Option
-	HRD30A8203 D30A8-20332	Backrest 挡货架	1	选用 Option
06	HRD30K0601 D30K0-60211	Lift bracket 货叉架	1	标准 STD
-	HRD30K0601 D30K0-60271	Lift bracket 货叉架	1	选用 Option
07	B6150-00030	Snap ring 挡圈30	2	GB894.1-86
08	22198-22341	End roller 滚轮 $\varnothing 91.5$	2	
09	980811N-00	End roller 滚轮 $\varnothing 119.2 \times 55-34$	6	
10	B6150-00055	Snap ring 挡圈55	6	GB894.1-86
11	24609-42131	Shaft 侧滚轮轴	2	
12	24609-42151	Shim 调整垫片1	6	
13	24609-42161	Shim 调整垫片0.2	8	
14	20037-42191	Shim 垫块3	4	

H

图126/FIG126

门架(基本型)/MAST (NORMAL MAST M)

H7

序号 Item No	图号 Part No	零部件名称 Description	件数 Q'ty	备注 Remark
01	22018-30064	Cap 支座盖	2	
02	D20B8-02001	Bushing 轴衬	4	
03	B0430-16065	Bolt 螺栓M16x1.5x65	4	GB5785-86
04	B5050-00016	Washer 垫圈16	2	GB93-87
05	Q701B45	Fitting 弯颈式滑脂嘴45°	2	ZBT33001.2-88 21.2.5t
-	Q700B01	Fitting 直通式滑脂嘴	2	ZBT33001.1-88 3t
06	HRH22A8309 H22A8-00201L	Pin 倾斜缸销轴	2	
07	B0530-10020	Bolt 螺栓M10x1.25x20	2	GB5786-86
08	B5050-00010	Washer 垫圈10	2	GB93-87
09	HRD24C8301A	Outer mast 外门架总成	1	2t,2.5t
-	HRD24N8301A	Outer mast 外门架总成	1	3t
10	HRD24C8303A	Inner mast 内门架总成	1	2t,2.5t
-	HRD24N8303A	Inner mast 内门架总成	1	3t
11	23458-32051	Shaft 侧滚轮组II	4	
12	22548-34051	Shim 调整垫圈	选用	
13	23818-30071	Spacer 垫块	8	
14	B0330-12040	Bolt 螺栓M12x40	8	GB5783-86
15	B5050-00012	Washer ,lock 垫圈12	8	GB93-87
16	23658-33001	Roller 滚轮2 ϕ 109.7	2	
17	B6152-00040	Snap ring 挡圈40	2	GB894.1-86
18	980811N-00	Roller 主滚轮 ϕ 119.2X55-34	2	
19	22548-34061	Shim 调整垫圈	8	
20	20028-32001*G	Slipper 限位滑块	2	
21	20029-43231*1	Shim 调整垫片0.5	AR	
-	20029-43231*2	Shim 调整垫片1.0	AR	
22	B4116-00010	Nut 螺母M10	2	GB6170-86
23	D24C8-62001	Shaft 限位轴	2	
24	B8030-10040	Screw 螺钉M10X40	2	GB70-85
25	B6152-00055	Snap ring 挡圈55	2	GB894.1-86

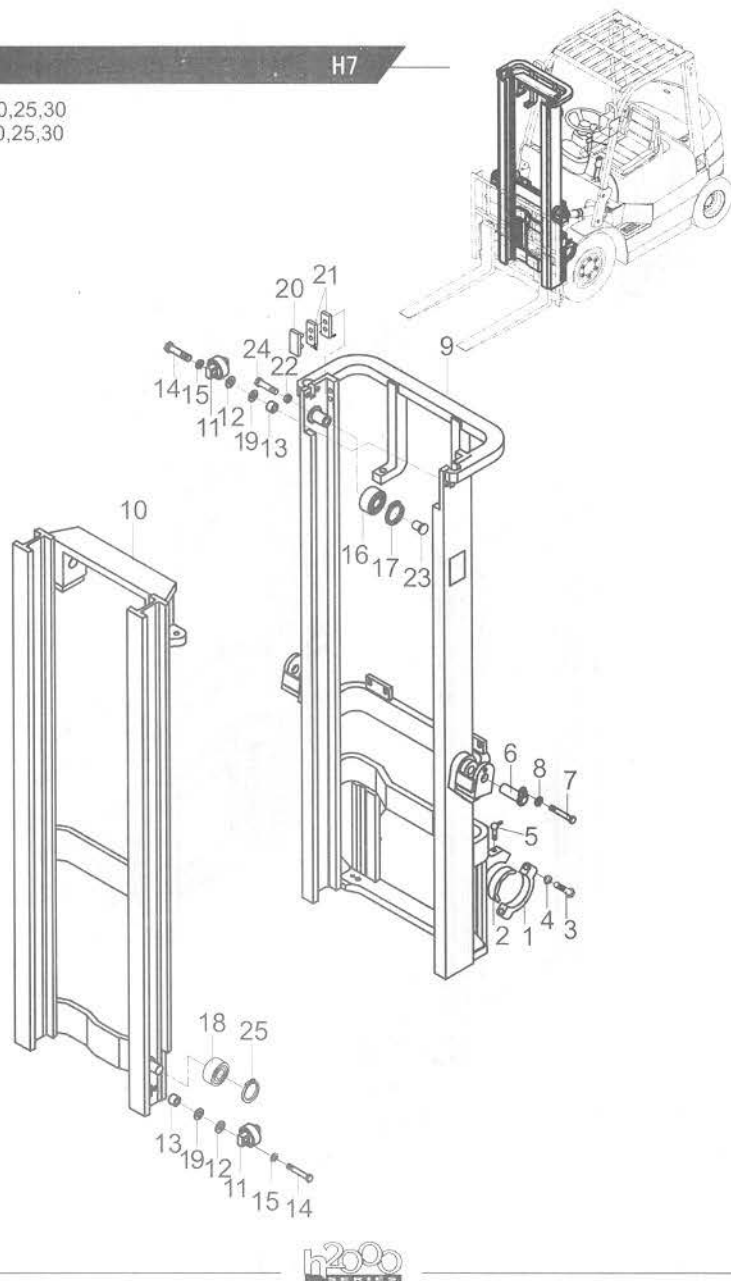
CPQ,CPQD20,25,30
CPC,CPCD20,25,30

H

图127/FIG127

门架(基本型)/MAST (NORMAL MAST)

H8

序号 Item No	图号 Part No	零部件名称 Description	件数 Q'ty	备注 Remark
01	HRD30A8301A	Mast ass'y,outer 外门架总成	1	见选用件表 See op.parts
02	27419-43321	Rubber,cushion 缓冲垫	1	
03	D20B8-31201	Bracket,cushion 缓冲支架	1	
04	B0530-16035	Bolt 螺栓M16X1.5X35	2	GB5786-86
05	B5050-00016	Washer,lock 垫圈16	6	GB93-87
06	B1210-06010	Screw 螺钉M6X10	2	GB818-85
07	B5310-00006	Washer 垫圈6	2	GB97.1-85
08	Q700B01	Grease port 直通式滑脂嘴	2	ZBT33001.1-88
09	HRD30A8304A	Mast ass'y,inner 内门架总成	1	见选用件表 See op.parts
10	980811N-00	End roller 主滚轮 $\varnothing 119.2 \times 55-34$	2	
11	B6150-00055	Snap ring 挡圈55	2	GB894.1-86
12	23658-33001	Roller 滚轮2	2	
13	B6150-00040	Snap ring 挡圈40	2	GB894.1-86
14	B0430-16065	Bolt 螺栓M16X1.5X65	4	GB5785-86
15	20028-34071	Spacer 垫块	4	
16	D20B8-02001	Bushing 轴衬	2	
17	22548-34051	Shim 调整垫圈	AR	
18	22548-34061	Shim 调整垫圈	AR	
19	B0530-12035	Bolt 螺栓M12X1.25X35	4	GB5786-86
20	B5050-00012	Washer,lock 垫圈12	8	GB93-87
21	23458-32051	Side roller 侧滚轮组II	2	
22	23818-30071	Spacer 垫块	4	
23	D20B8-02021	Pin axle 销轴	2	
24	23648-50161	Plate,stopper 卡板	2	
25	B0530-12040	Bolt 螺栓M12X1.25X40	4	GB5786-86
26	B0530-10020	Bolt 螺栓M10X1.25X20	4	GB5786-86
27	20028-32001*G	Slipper 限位滑块	2	
28	20029-43231*1	Shim 调整垫片0.5	AR	
-	20029-43231*2	Shim 调整垫片1.0	AR	
29	22018-30064	Cap 支座盖	2	GB93-87

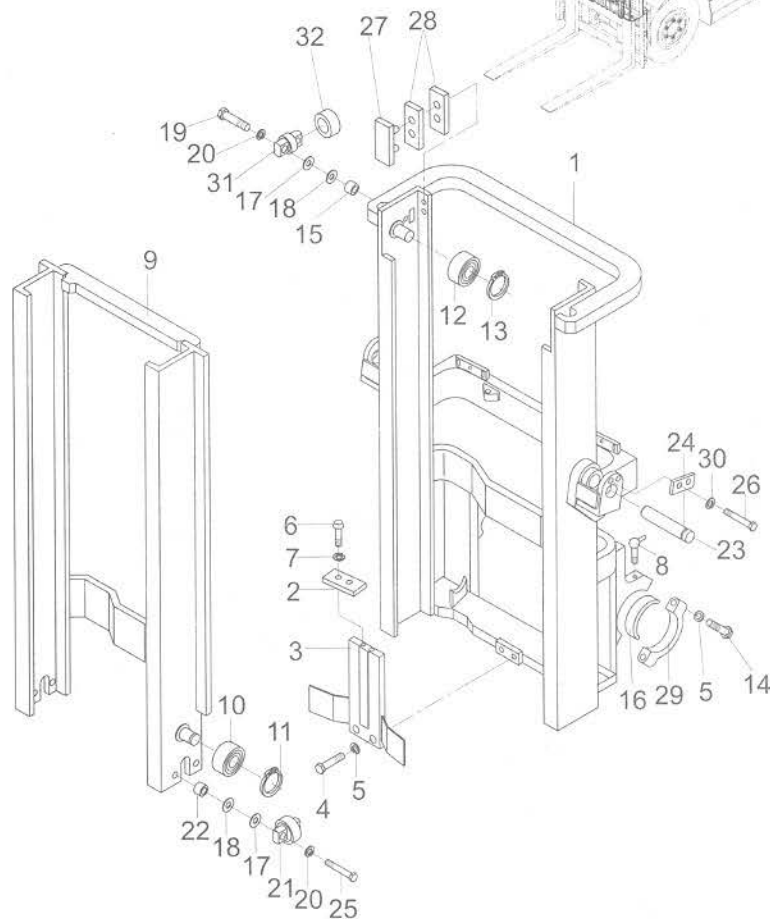
CPQ,CPQD35
CPC,PCPD35

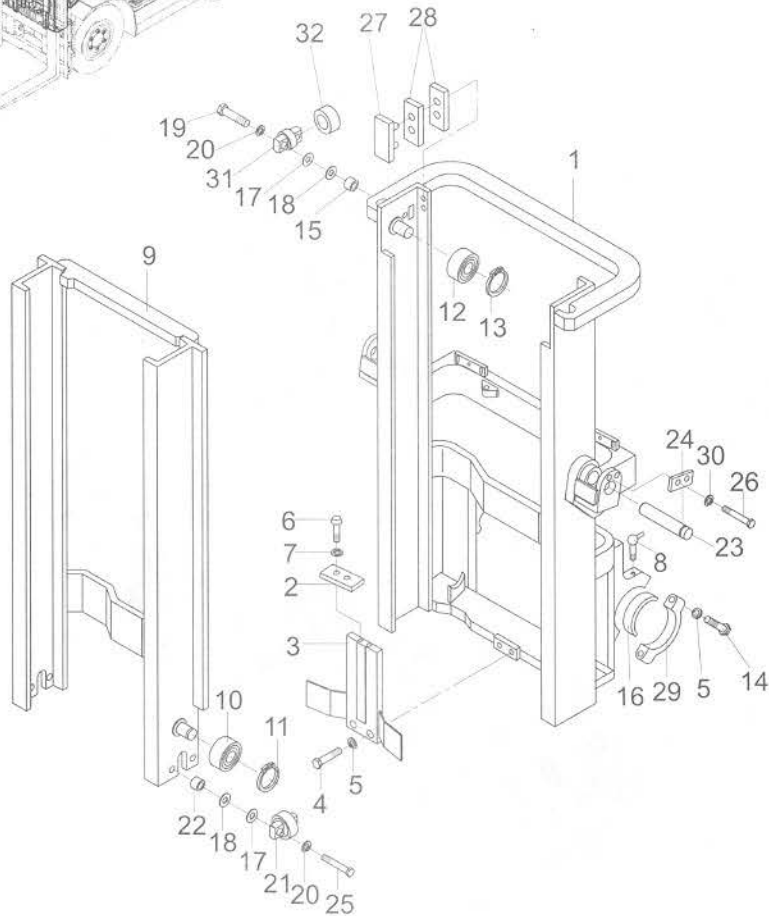
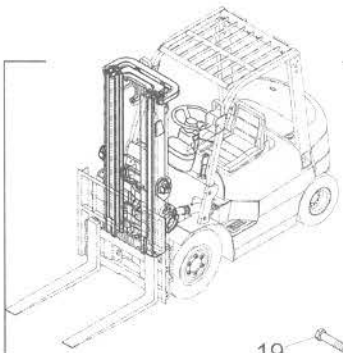

CPQ,CPQD35
CPC,CPCD35

序号
Item
No

图号
Part No

零部件名称
Description

件数
Q'ty

备注
Remark

30	B5050-00010	Washer,lock	垫圈10	4	
A	22548-30601	Side roller(Inc.31,32)	侧滚轮组1∅80	2	
31	22548-34021	Shaft	轴	2	
32	22578-22401	Roller	限位滚轮	2	

门架选用件表 Mast Optional Parts

起升高度 IFTING HEIGHT	外门架总成 OUTER MAST	内门架总成 INNER MAST	备注 REMARK
M200	D30A8-30212	H30A8-30412	
250	-30222	-30422	
270	-30232	-30432	
300	-30202	-30402	标准 STD
330	-30242	-30442	
350	-30252	-30452	
370	-30262	-30462	
400	-30272	-30472	
425	-30282	-30482	
450	-30292	-30492	
475	-30312	-30512	
500	-30322	-30522	
550	-30332	-30532	
600	-30342	-30542	

CPQ,CPQD35
CPC,CPCD35

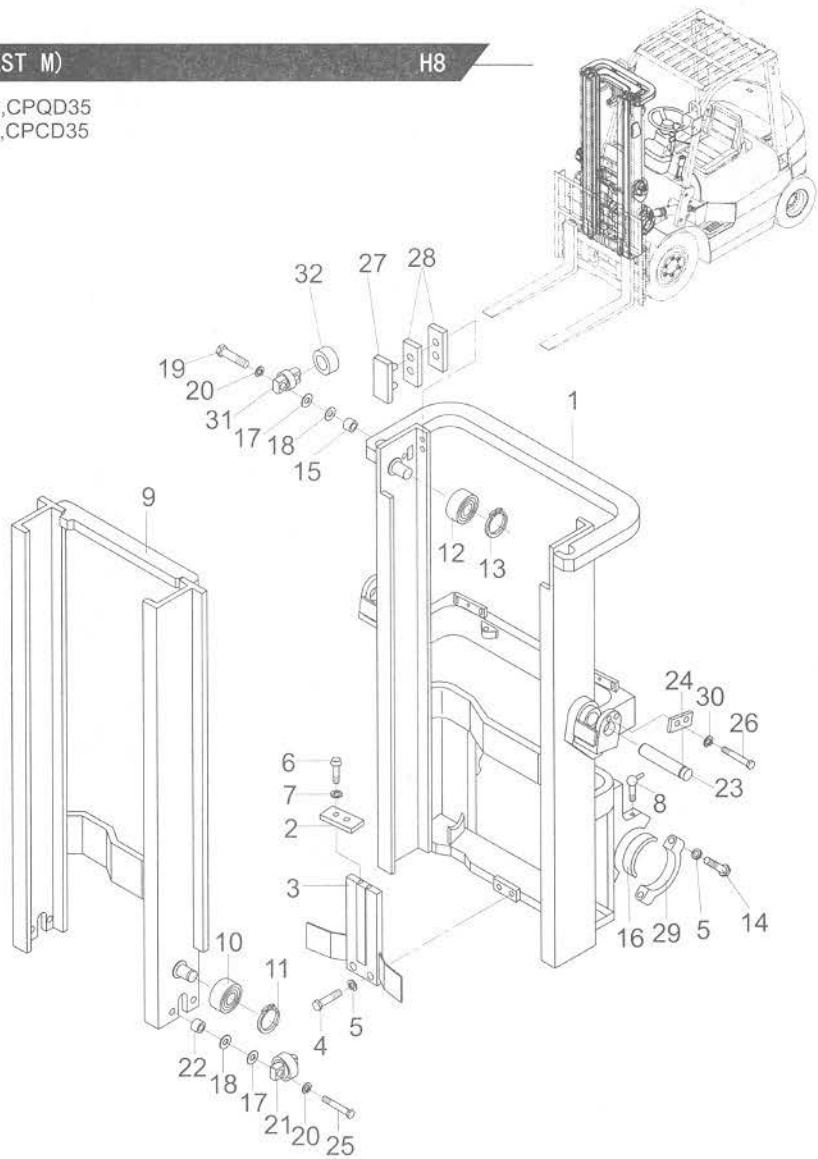

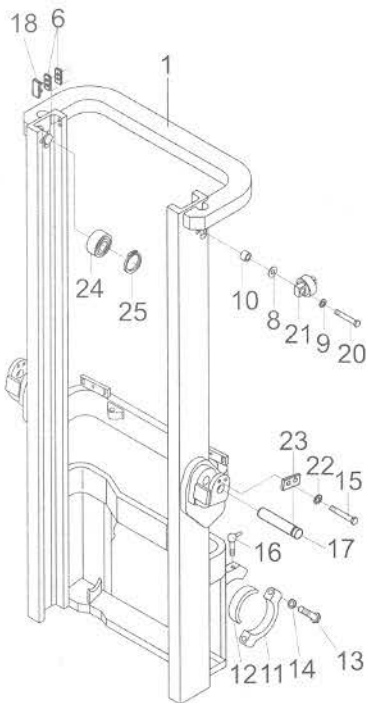
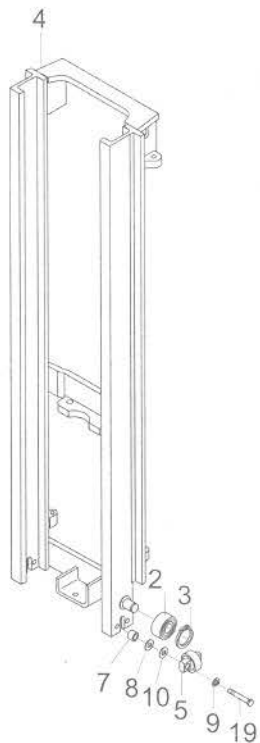
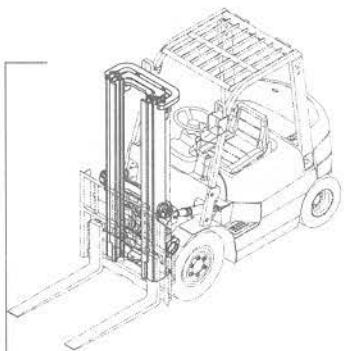

H9

门架(二级全自由)/MAST (FULL FREE 2-STAGE MAST ZM)

图128/FIG128

CPQ,CPQD20,25
CPC,PCPD20,25

序号 Item No	图号 Part No	零部件名称 Description	件数 Q'ty	备注 Remark
01	HRD20L0401A	Mast ass'y,outer 外门架总成	1	
02	980811N-00	End roller 主滚轮 \varnothing 119. 2X55-34	2	
03	B6150-00055	Snap ring 挡圈55	2	GB894.1-86
04	HRD20L0402A	Mast ass'y,inner 内门架总成	1	
05	23458-32051	Side roller 侧滚轮组II \varnothing 58	2	
06	20029-43231*1	Shim 调整垫片0.5	AR	
-	20029-43231*2	Shim 调整垫片1.0	AR	
07	23818-30071	Spacer 垫块	4	
08	22548-34061	Shim 调整垫圈	4	
09	B5050-00012	Washer,lock 垫圈12	8	GB93-87
10	22548-34051	Shim 调整垫圈	4	
11	22018-30064	Cap 支座盖	2	
12	D20B8-02001	Bushing 轴衬	2	
13	B0430-16065	Bolt 螺栓M16X1. 5X65	4	GB5785-86
14	B5050-00016	Washer,lock 垫圈16	4	GB93-87
15	B0530-10020	Bolt 螺栓M10X1. 25X20	4	GB5786-86
16	Q701B45	Grease port 弯颈式滑脂嘴	2	ZBT33001.2-88
17	D20B8-02021	Pin axle 销轴	2	
18	20028-32001*G	Slipper 限位滑块	2	
19	B0330-12040	Bolt 螺栓M12X40	4	GB5783-86
20	B0530-12035	Bolt 螺栓M12X1. 25X35	4	GB5786-86
21	D20B8-31211	Side roller 侧滚轮组I	2	
22	B5050-00010	Washer,lock 垫圈10	4	GB93-87
23	23648-50161	Plate,stopper 卡板	2	
24	23658-33001	Roller 滚轮2 \varnothing 109.7	2	
25	B6150-00040	Snap ring 挡圈40	2	GB894.1-86

门架选用件表 MAST OPTIONAL PARTS

CPQ,CPQD20,25
CPC,CPCD20,25

起升高度 LIFTING HEIGHT	外门架总成 OUTER MAST	内门架总成 INNER MAST	备注 REMARK
ZM200	HRD20L0401A D20L0-40212	HRD20L0402A D20L0-40512	
225	-40222	-40522	
250	-40232	-40532	
275	-40242	-40542	
270	-40252	-40552	
300	-40202	-40502	标准 (STD)
325	-40262	-40662	
330	-40272	-40772	
350	-40282	-40882	
366	-40292	-40792	
370	-40312	-40812	
375	-40322	-40822	
400	-40332	-40832	
425	-40342	-40842	
450	-40352	-40852	
475	-40362	-40862	
500	-40372	-40872	
550	-40382	-40682	
600	-40392	-40892	

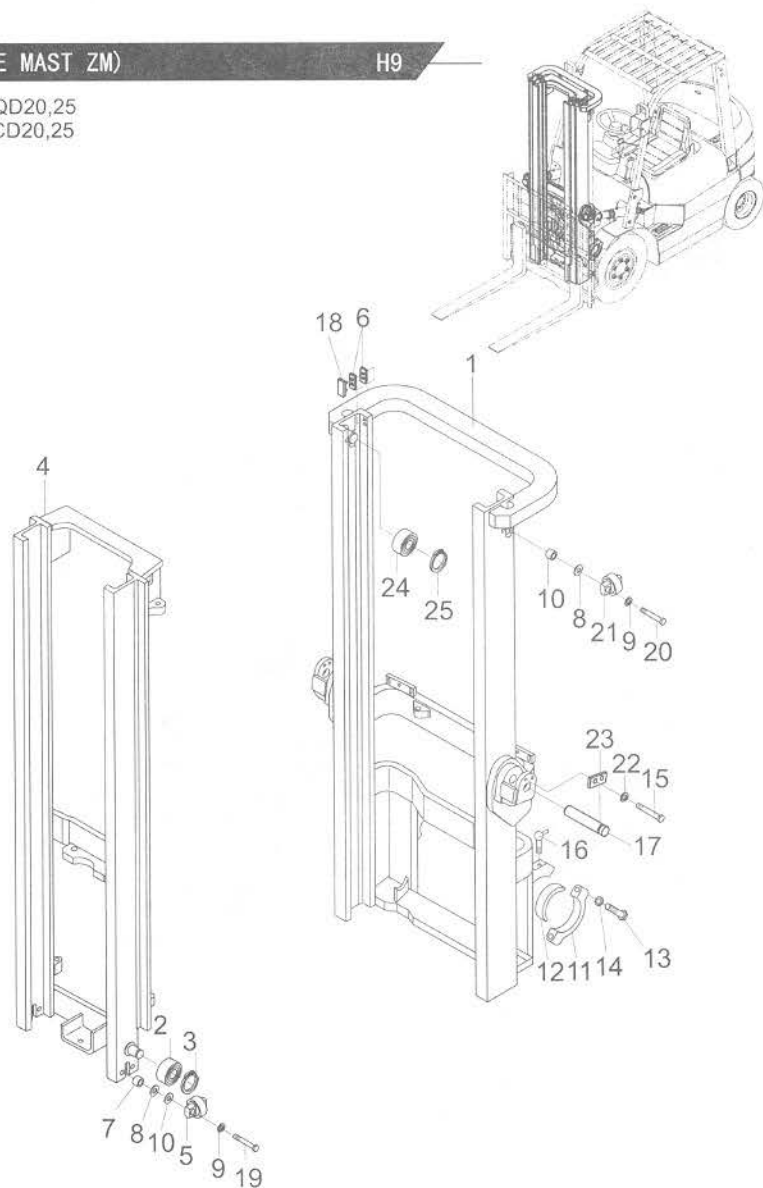

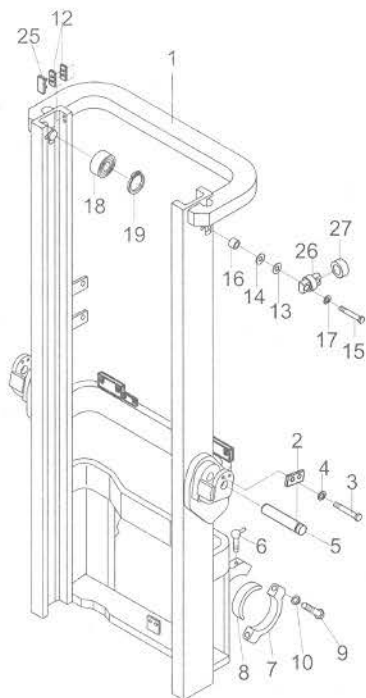
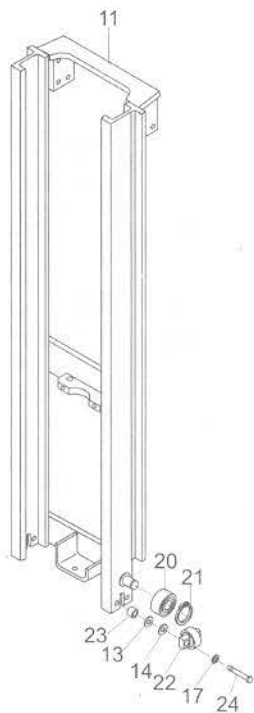
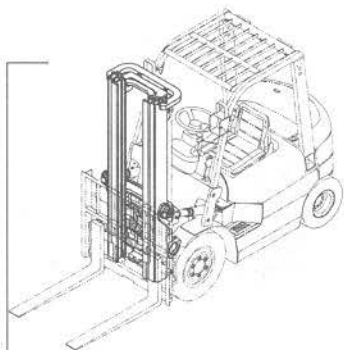

H10

门架(二级全自由)/MAST(FULL FREE 2-STAGE MAST ZM)

图129/FIG129

CPC,CPD30
CPQ,CPQD30

序号 Item No	图号 Part No	零部件名称 Description	件数 Qty	备注 Remark
01	HRD28L0401A	Outer mast	1	外门架总成 见选用件表 See Op. Parts
02	23648-50161	Plate,stopper	2	卡板
03	B0530-10020	Bolt	4	螺栓M10X1.25X20 GB5786-86
04	B5050-00010	Washer,lock	4	垫圈10 GB93-87
05	D20B8-02021	Pin	2	销轴
06	Q700B01	Fitting	2	直通式滑脂嘴 GB1152-76
07	22018-30064	Cap	2	支座盖
08	D20B8-02001	Bushing	2	轴衬
09	B0430-16070	Bolt	4	螺栓M16X1.5X70 GB5785-86
10	B5050-00016	Washer,lock	6	垫圈16 GB93-87
11	HRD28L0402A	Inner mast	1	内门架总成 见选用件表 See Op. Parts
12	20029-43231*1	Shim	0.5	调整垫片0.5 AR
-	20029-43231*2	Shim	1.0	调整垫片1.0 AR
13	22548-34051	Shim	10	调整垫圈
14	22548-34061	Shim	14	调整垫圈
15	B0530-12035	Bolt	4	螺栓M12X1.25X35 GB5786-86
16	20028-34071	Spacer	4	垫块
17	B5050-00012	Washer,lock	8	垫圈12 GB93-87
18	23658-33001	Roller	2	滚轮 $\varnothing 109.5$
19	B6152-00040	Snap ring	2	挡圈40 GB894.1-86
20	980811N-00	Roller	2	滚轮 $\varnothing 119.2 \times 55-34$
21	B6150-00055	Snap ring	2	挡圈55 GB894.1-86
22	23458-32051	Side roller	2	侧滚轮组 $\varnothing 58$
23	23818-30071	Spacer	4	垫块
24	B0330-12040	Bolt	4	螺栓M12X40 GB5783-86
25	20028-32001	Slipper	2	限位滑块
A	22548-30601	Side roller(Inc.26,27)	2	侧滚轮组 $1 \varnothing 80$
26	22548-34021	Shaft	2	轴
27	22578-22401	Roller	2	限位滚轮

门架选用件表 MAST OPTIONAL PARTS

CPC, CPCD30
CPQ, CPQD30

起升高度 LIFTING HEIGHT	外门架总成 OUTER MAST	内门架总成 INNER MAST	备注 REMARK
ZM200	HRD28L0401A D28L0-40212	HRD28L0402A D28L0-40512	
225	-40222	-40522	
250	-40232	-40532	
270	-40242	-40542	
275	-40252	-40552	
300	-40202	-40502	
325	-40262	-40662	
330	-40272	-40772	
350	-40282	-40882	
366	-40292	-40792	
370	-40312	-40812	
375	-40322	-40822	
400	-40332	-40832	
425	-40342	-40842	
450	-40352	-40852	
475	-40362	-40862	
500	-40372	-40872	
550	-40382	-40902	
600	-40392	-40892	

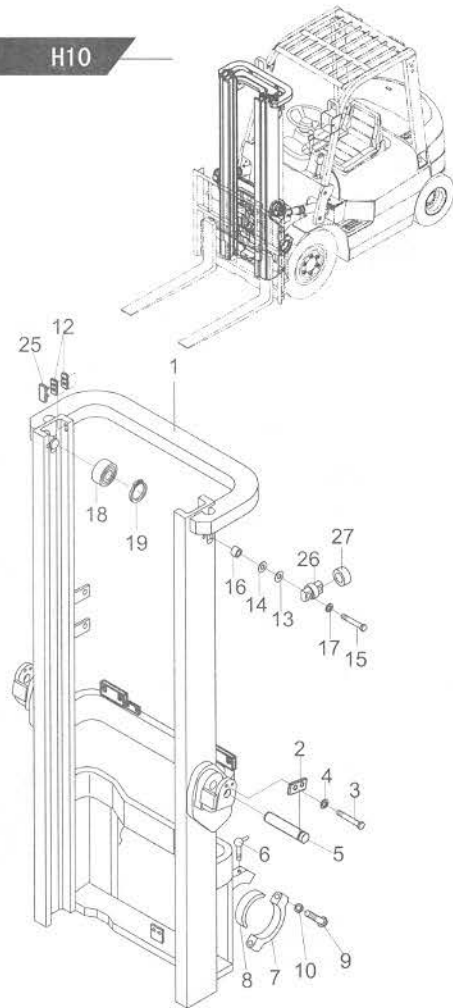
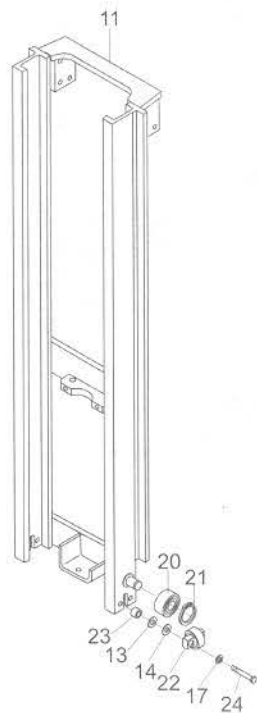

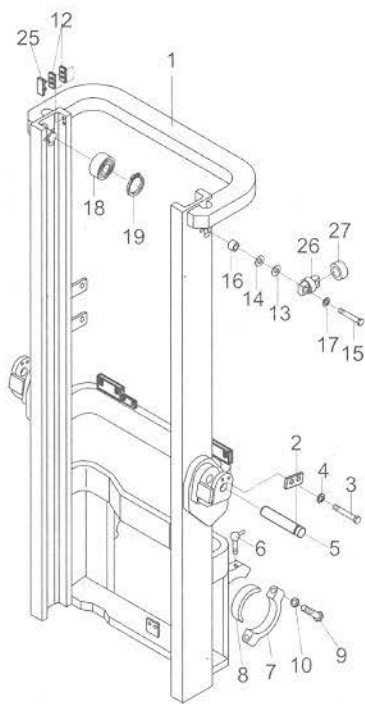
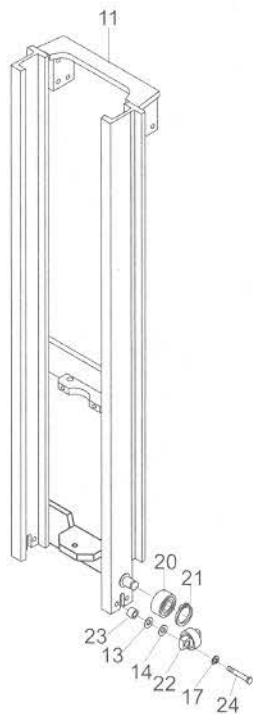
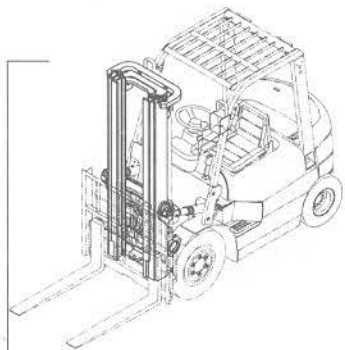

H11

门架(二级全自由)/MAST(FULL FREE 2-STAGE MAST ZM)

图130/FIG130

CPC,CPD35
CPQ,CPQD35

序号 Item No	图号 Part No	零部件名称 Description	件数 Q'ty	备注 Remark
01	HRD30K0402A	Outer mast	1	外门架总成 见选用件表 See Op. Parts
02	23648-50161	Plate,stopper	2	卡板
03	B0530-10020	Bolt	4	螺栓M10X1.25X20 GB5786-86
04	B5050-00010	Washer,lock	4	垫圈10 GB93-87
05	D20B8-02021	Pin	2	销轴
06	Q700B01	Fitting	2	直通式滑脂嘴 GB1152-76
07	22018-30064	Cap	2	支座盖
08	D20B8-02001	Bushing	2	轴衬
09	B0430-16065	Bolt	4	螺栓M16X1.5X65 GB5785-86
10	B5050-00016	Washer,lock	6	垫圈16 GB93-87
11	HRD30K0403A	Inner mast	1	内门架总成 见选用件表 See Op. Parts
12	20029-43231*1	Shim	AR	调整垫片0.5
-	20029-43231*2	Shim	AR	调整垫片1.0
13	22548-34051	Shim	10	调整垫圈
14	22548-34061	Shim	14	调整垫圈
15	B0530-12035	Bolt	4	螺栓M12X1.25X35 GB5786-86
16	20028-34071	Spacer	4	垫块
17	B5050-00012	Washer,lock	8	垫圈12 GB93-87
18	23658-33001	Roller	2	滚轮 $\varnothing 109.5$
19	B6150-00040	Snap ring	2	挡圈40 GB894.1-86
20	980811N-00	Roller	2	滚轮 $\varnothing 119.2 \times 55-34$
21	B6150-00055	Snap ring	2	挡圈55 GB894.1-86
22	23458-32051	Side roller	2	侧滚轮组 $\varnothing 58$
23	23818-30071	Spacer	4	垫块
24	B0530-12040	Bolt	4	螺栓M12X1.25X40 GB5786-86
25	20028-32001*G	Slipper	2	限位滑块
A	22548-30601	Side roller(Inc.26,27)	2	侧滚轮组I $\varnothing 80$
26	22548-34021	Shaft	2	轴
27	22578-22401	Roller	2	限位滚轮

门架选用件表 MAST OPTIONAL PARTS

CPC, CPCD35
CPQ, CPQD35

起升高度 LIFTING HEIGHT	外门架总成 OUTER MAST	内门架总成 INNER MAST	备注 REMARK
KM200	HRD30K0402A D30K0-30212	HRD30K0403A D30K0-30412	
250	-30222	-30422	
270	-30232	-30432	
300	-30202	-30402	标准 (STD)
330	-30242	-30442	
350	-30252	-30452	
370	-30262	-30462	
400	-30272	-30472	
425	-30282	-30482	
450	-30292	-30492	
475	-30312	-30512	
500	-30322	-30522	
550	-30332	-30532	
600	-30342	-30542	

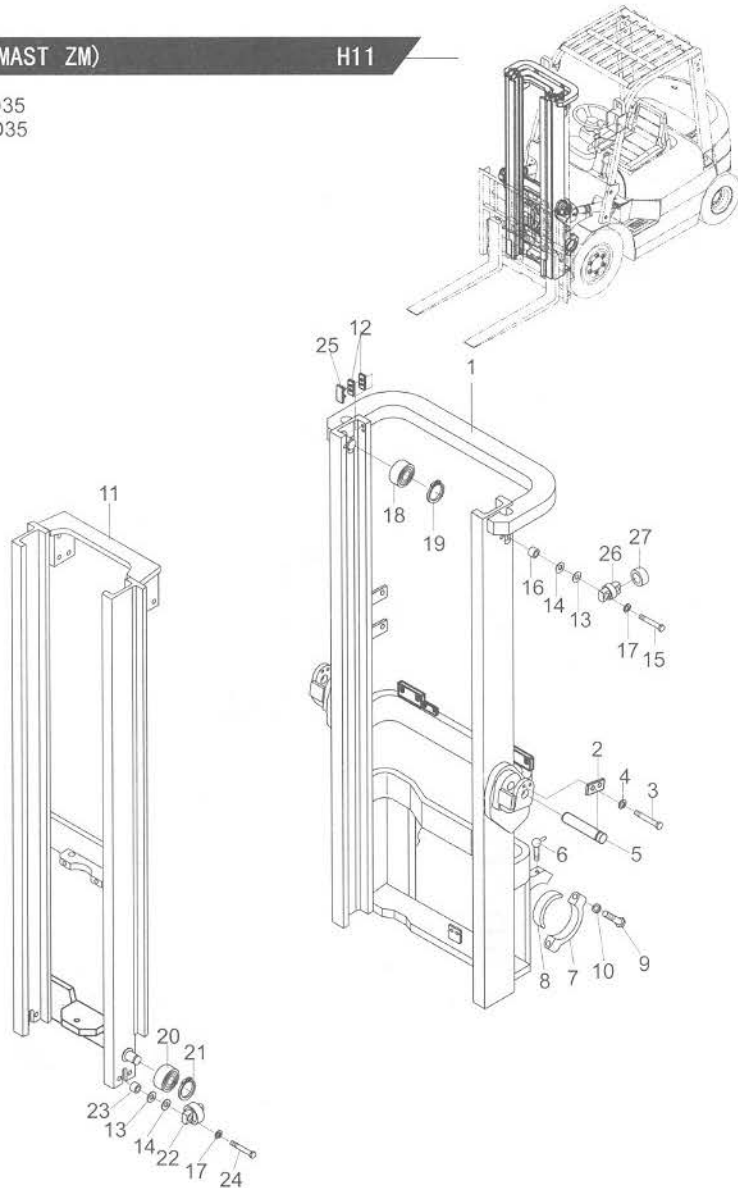

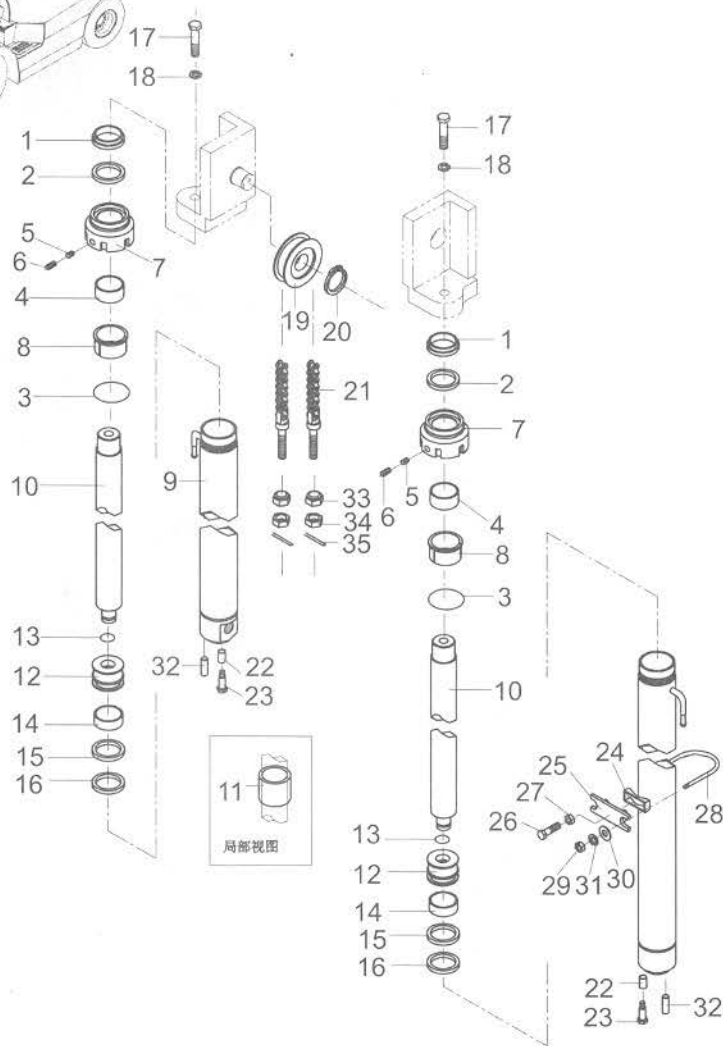
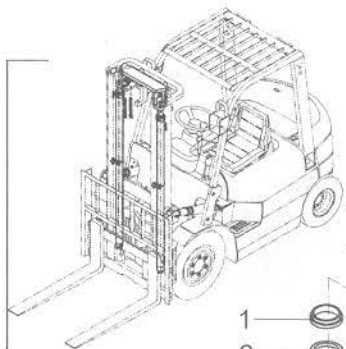

CPQ,CPQD20,25,30
CPC,CPCD20,25,30

序号 Item No	图号 Part No	零部件名称 Description	件数 Q'ty	备注 Remark
A	HRD24C8402	Lift cylinder (Inc.1~16) 起升油缸总成	2	2t,2.5t 见选用件表 See op.parts
-	HRH26A8402	Lift cylinder (Inc.1~16) 起升油缸总成	2	3t 见选用件表 See op.parts
01	HRD20A8508 D20B8-42321	Seal 防尘圈	2	2t,2.5t
-	HRD20A8508 D28B8-42441	Seal 防尘圈	2	3t
02	HRD20B8406 D20B8-42331	Packing 密封圈	2	2t,2.5t
-	HRD20B8406 D28B8-42611	Packing 密封圈	2	3t
03	D20B8-42391	Bushing 钢背轴承	2	2t,2.5t
-	D28B8-42461	Bushing 钢背轴承(4530)	2	3t
04	Z6053-05302	O-ring 0形圈53x2.65	2	GB3452.1-92 2t,2.5t
-	Z6003-06803	O-ring 0形圈68x3.1	2	GB1235-76 3t
05	D20B8-42341	Plug 塞子	4	
06	B1830-08008	Screw 螺钉M8x8	4	GB80-85
07	H22A8-42001	Cap 导向套	2	2t,2.5t
-	H26A8-42001	Cap 导向套	2	3t
08	H22A8-42011	sleeve 衬套	2	2t,2.5t
-	H26A8-42011	sleeve 衬套	2	3t
09	HRH22A8403	Cylinder 缸体	2	2t,2.5t 见选用件表 See op.parts
-	HRH26A8403	Cylinder 缸体	2	3t 见选用件表 See op.parts
10	HRD24C8403	Rod 活塞杆	2	2t,2.5t 见选用件表 See op.parts
-	HRD28B8405	Rod 活塞杆	2	3t 见选用件表 See op.parts
11	HRD20A8405 D20A8-42451	Spacer 调整套	见	表 2t,2.5t
-	HRD20A8405 D28A8-43131	Spacer 调整套	见	表 3t
12	D20B8-42371	Piston 活塞	2	2t,2.5t
-	D28B8-42411	Piston 活塞	2	3t
13	D20B8-42381	snap ring 钢丝挡圈	2	
14	HRD20A8409 D20A8-42531	Wearing 支承环	2	2t,2.5t
-	HRD20A8409 D28A8-43171	Wearing 支承环	2	3t
15	HRD20A8509 D20A8-42541	Snap ring 挡片	2	2t,2.5t
-	HRD20A8509 D28A8-43181	Snap ring 挡片	2	3t
16	HRD20A8505 D20A8-42551	U-ring U形密封圈	<	2t,2.5t

图131/FIG131

起升油缸 (基本型)/LIFT CYLINDER (NORMAL MAST M)

H12

序号 Item No	图号 Part No	零部件名称 Description	件数 Q'ty	备注 Remark
-	HRD20A8405 D28A8-43191	U-ring U形密封圈	2	3t
17	B0530-16040	Bolt 螺栓M16x1.5x40	2	GB5786-86
18	B5050-00016	Washer 垫圈16	2	GB93-87
19	Z3659-44842	Sheave 链轮	2	
20	B6150-00040	Snap ring 弹性挡圈40	2	GB894.1-86
21	HRLH1234021	Chain (Inc.33~35) 链条总成	2	2t,2.5t 见选用件表 See op.parts
-	HRLH1623011	Chain (Inc.33~35) 链条总成	2	3t 见选用件表 See op.parts
22	HRD20B8407 D20B8-42031	Sleeve 隔套	2	
23	B0530-12025	Bolt 螺栓M12x1.25x25	2	GB5786-86
24	D20B8-42051	Spacer 调整块	2	
25	D20B8-42041	Support 油缸支撑块	2	
26	B0530-12050	Bolt 螺栓M12x1.25x50	2	GB5786-86
27	B4223-00012	Nut 螺母M12x1.25	2	GB6171-86
28	HRD208408 D20B8-42061	U-bolt U型螺栓	2	
29	B4413-00010	Nut 螺母M12x1.25	4	GB6173-86
30	B5310-00010	Washer 垫圈10	4	GB97.1-85
31	B5050-00010	Washer 弹簧垫圈10	4	GB93-87
32	B3130-10026	Pin 销B10x26	2	GB119-86
33	Z2198-40192G	Nut 螺母	4	
34	B4230-00018	Nut 螺母M18x1.5	4	GB6171-86
35	B3010-03030	Pin 开口销3x30	4	GB91-86

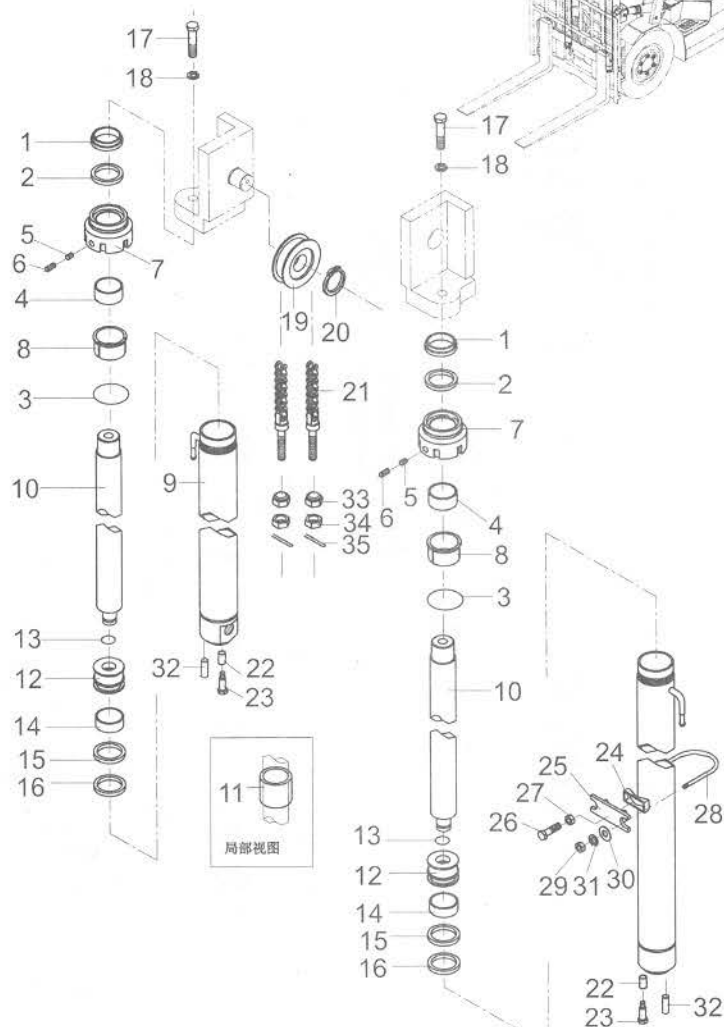
CPQ,CPQD20,25,30
CPC,CPCD20,25,30

H

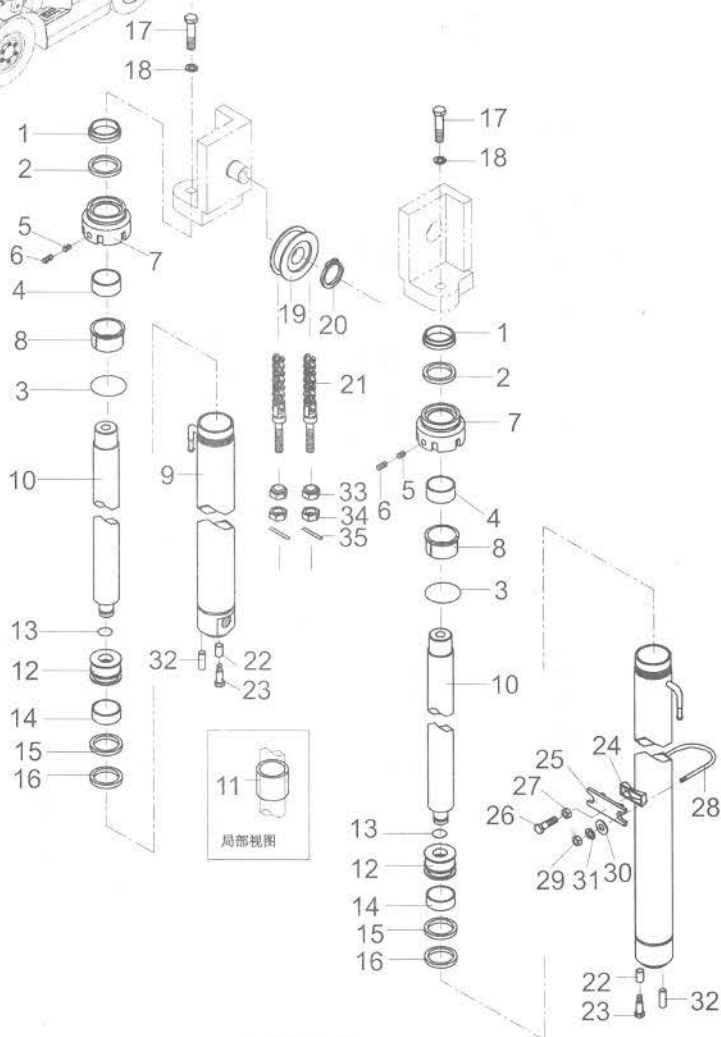
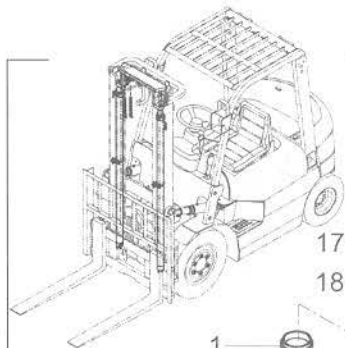

起升油缸选用件 OPTION TABLE FOR LIFT CYLINDER

起升高度 IFTING HEIGHT	起升油缸总成 LIFT CYL	缸体 LYL. BODY	活塞杆 RID. PISTON	链条总成 CHAIN ASS'Y	调整套(个) SPACER(N)
M200	D24C8 -40411	H22A8 -40611	D24C8 -42311	HRLH1234021 -75	
250	-40421	-40621	-42321	-87	
270	-40431	-40631	-42331	-93	
标准 (STD)	-40401	-40601	-42301	-101	
330	-40441	-40641	-42341	-109	
350	-40451	-40651	-42351	-115	
370	-40461	-40661	-42361	-119	
400	-40471	-40671	-42371	-129	1
425	-40481	-40681	-42381	-137	1
450	-40491	-40691	-42391	-143	1
475	-40511	-40711	-42411	-149	1
500	-40521	-40721	-42421	-157	1
550	-40531	-40731	-42431	-171	2
600	-40541	-40741	-42441	-185	2

起升油缸选用件 OPTION TABLE FOR LIFT CYLINDER

起升高度 IFTING HEIGHT	起升油缸总成 LIFT CYL	缸体 LYL. BODY	活塞杆 RID. PISTON	链条总成 CHAIN ASS'Y	调整套(个) SPACER (N)
M200	H26A8	H26A8	D28B8	HRLH1623011	
	-40411	-40611	-42211	-57	
250	-40421	-40621	-42231	-67	
270	-40431	-40631	-42241	-71	
标准 (STD)	300	-40401	-42201	-77	
	330	-40441	-42271	-83	
	350	-40451	-42281	-87	
	370	-40461	-42311	-91	
	380	-40551	-42991	-93	
	400	-40471	-42331	-99	1
	425	-40481	-42341	-103	1
	450	-40491	-42351	-109	1
	475	-40511	-42361	-113	1
	500	-40521	-42371	-119	1
	550	-40531	-42381	-131	2
	600	-40541	-42391	-151	2

CPQ,CPQD30
CPC,CPCD30

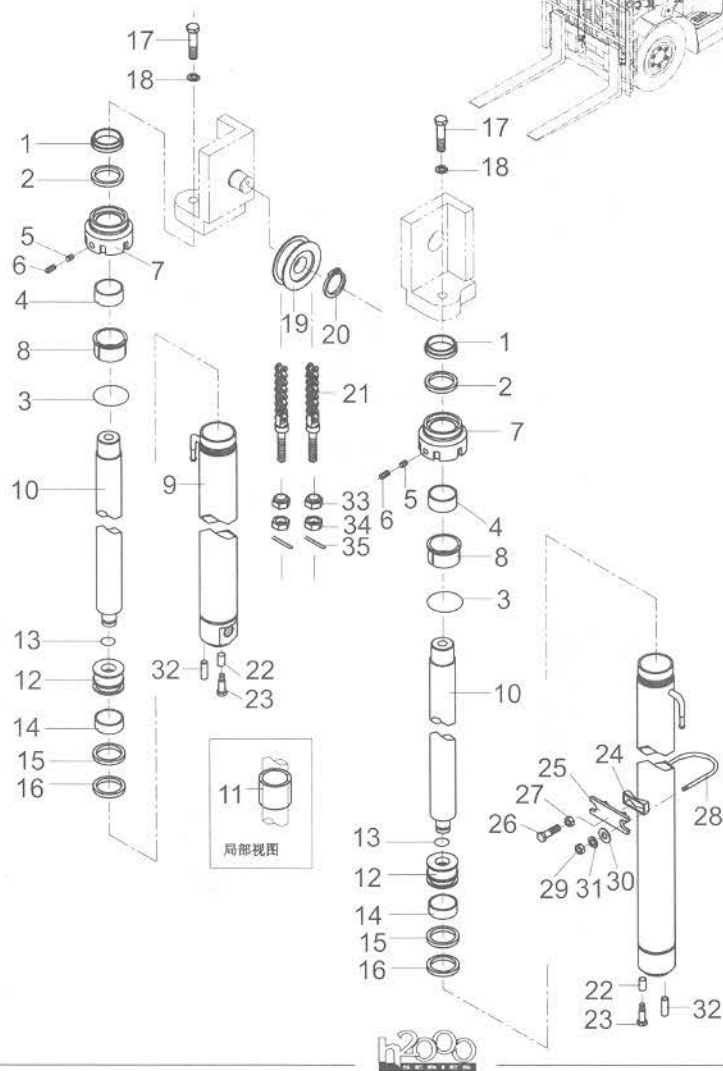

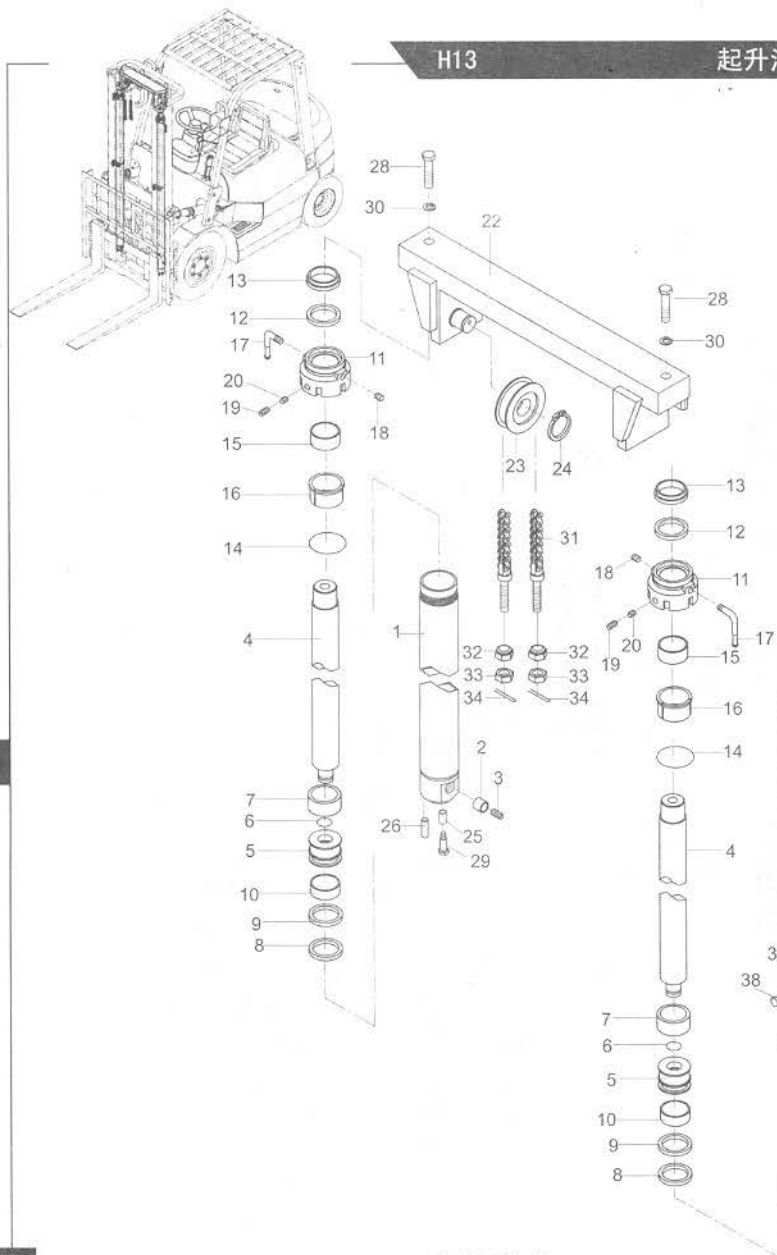
CPQ,CPQD35
CPC,PCPD35序号
Item
No图号
Part No零部件名称
Description件数
Q'ty备注
Remark

序号 Item No	图号 Part No	零部件名称 Description	件数 Q'ty	备注 Remark
A	HRD30A8406	Lift cylinder L.H. (Inc.01~20,26)	1	见选用件表 See op.parts
B	HRD30A8405	Lift cylinder R.H. (Inc.01~20,26)	1	见选用件表 See op.parts
01	HRD30A8409	Cylinder body L.H.	1	见选用件表 See op.parts
-	HRD30A8408	Cylinder body L.H.	1	见选用件表 See op.parts
02	24389-46011	Spool	1	右缸用 cylinder R.H.
03	REF339431 24389-46021	Spring	1	右缸用 cylinder R.H.
04	HRD30A8411	Piston rod	2	见选用件表 See op.parts
05	D42K0-52551	Piston	2	
06	D42K0-52541	Steel thread	2	
07	HRD30A8413 D30A8-42371	Sleeve, adjusted	2	用于M400,M425, M450,M470,M500
-	HRD30A8413 D30A8-42391	Sleeve, adjusted	2	用于M550,M600
08	REF340214 22439-43711	U-ring Seal	2	U型密封圈
09	24238-42031	Ring, backup	2	挡片
10	REF341311 24248-52251	Wearing	2	支承环
11	D30A8-42341	Cap	2	缸盖
12	REF340858 24329-45591	Ring seal	2	U型密封圈
13	ME-350A	Dust ring	2	防尘圈
14	Z6004-75003	O-ring seal	2	O型密封圈75X3.1 GB1235-76
15	D30A8-42361	Bushing	2	钢背轴承5040 GS-1
16	D30A8-42351	Bushing	2	衬套
17	D20A8-42421	Elbow	2	管接头
18	D20A8-42511	Plug	2	螺塞
19	B1830-08012	Screw	4	螺钉M8X12 GB80-85
20	D20B8-42341	Plug	4	塞子
21	B5311-00010	Washer	4	垫圈10 GB97.1-85
22	D30A8-40211	Active beam	1	活动梁
23	24609-41241	Sheave	2	链轮
24	B6150-00050	Snap ring	2	挡圈50 GB894.1-86
25	HRD20B8407 D20B8-42031	Spacer	2	隔套
26	23679-40050G	Pin	2	销

图132/FIG132

起升油缸(基本型)/LIFT CYLINDER(NORMAL MAST)

H13

序号 Item No	图号 Part No	零部件名称 Description	件数 Q'ty	备注 Remark
27	B5050-00010	Washer, lock 垫圈10	4	GB93-87
28	B0530-20055	Bolt 螺栓M20X1.5X55	2	GB5786-86
29	B0430-12025	Bolt 螺栓M12X1.25X25	2	GB5786-86
30	B5050-00020	Washer, lock 垫圈20	2	GB93-87
31	HRLH1634011	Chain ass'y(Inc.32~34) 链条总成	2	见选用件表 See op.parts
32	23818-30271	Nut 球形螺母	4	
33	B4230-00022	Nut 螺母M22X1.5	4	GB6171-86
34	B3010-02540	Pin 销2.5X40	4	GB91-86
35	D42K0-62111	Support 油缸支承块	2	
36	D42K0-62431	Rubber 调整块	2	
37	D30A8-42111	U-bolt U型螺栓	2	
38	B0520-12040	Bolt 螺栓M12X1.25X40	2	GB5786-86
39	B4218-00012	Nut 螺母M12X1.25	4	GB6171-86
40	B4218-00010	Nut 螺母M10X1.25	2	GB6171-86

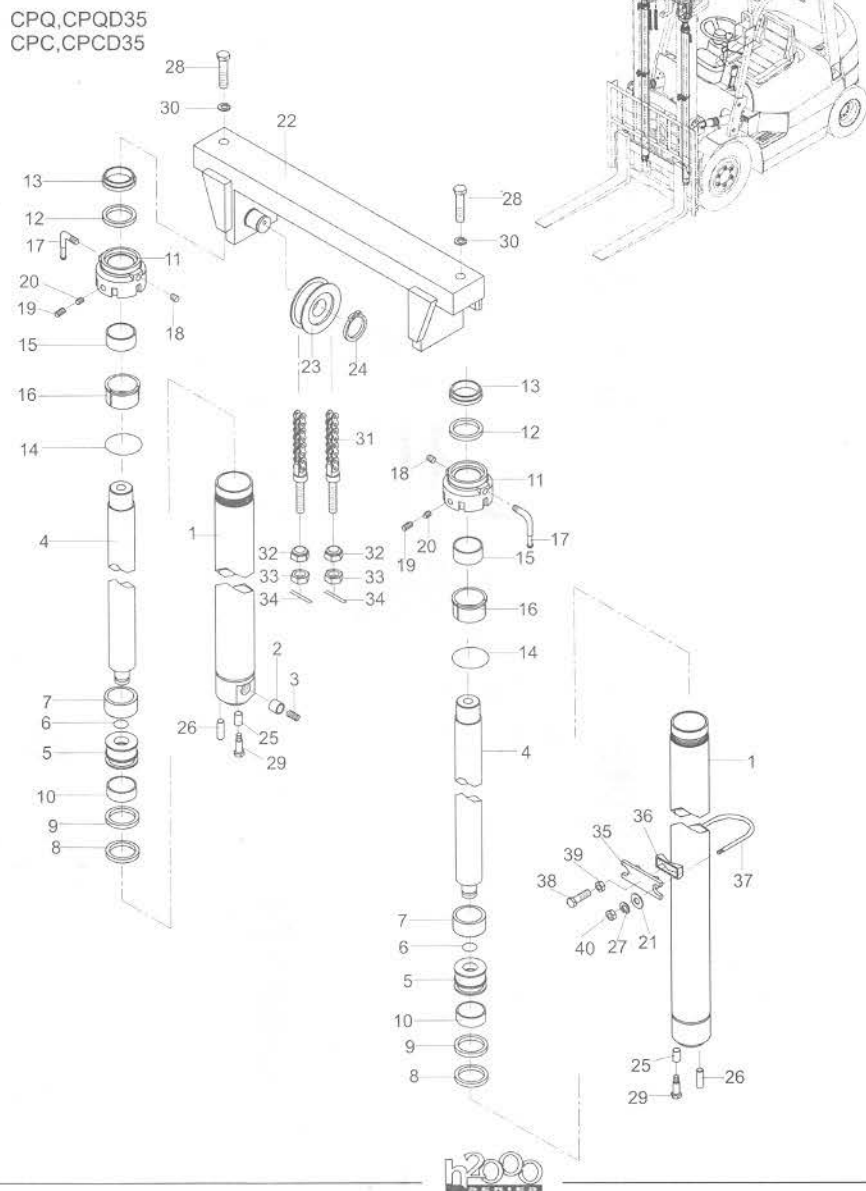

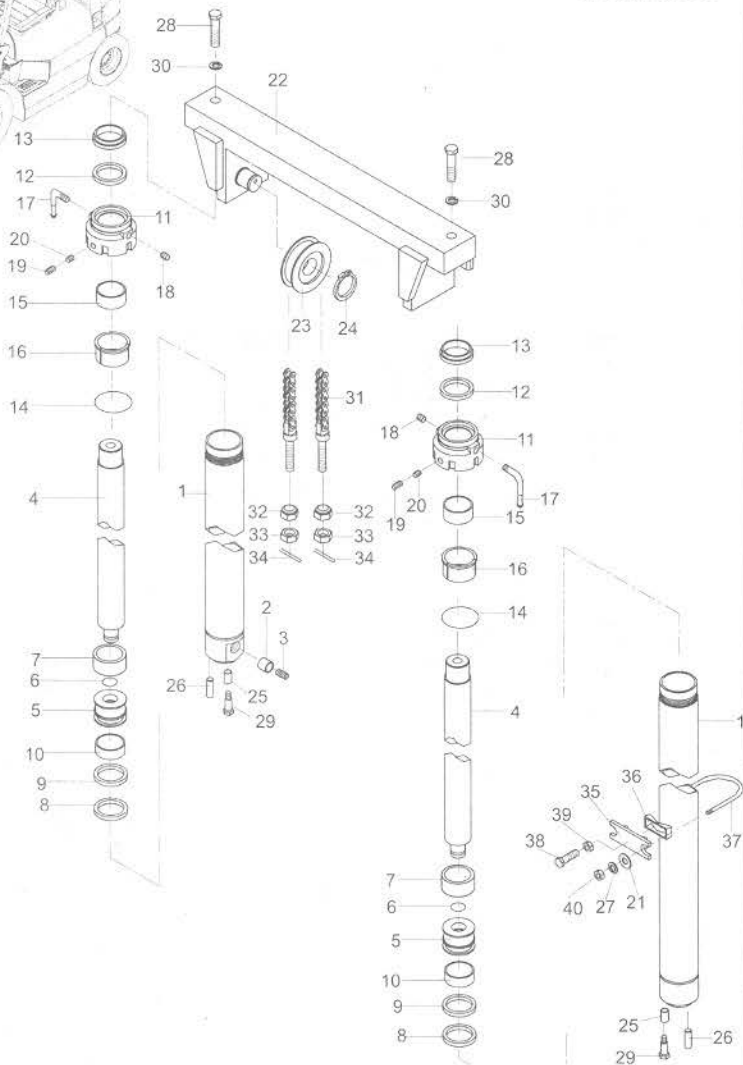
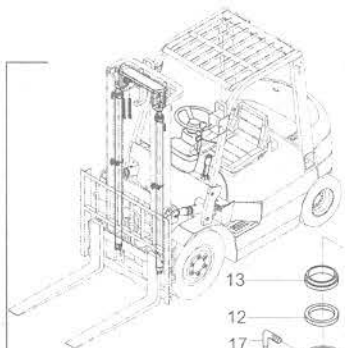

3.5t起升油缸选用件 (基本型)
LIFT CYLINDER OPTION TABLE (NORMAL MAST)

起升高度 IFTING HEIGHT	起升油缸 LIFT CYLINDER		缸体 CYLINDER BODY		柱塞杆 PISTON ROD	链条总成 CHAIN ASS'Y	备注 REMARKS
	左 L. H.	右 R. H.	左 L. H.	右 R. H.			
M200	D30A8 -40411	D30A8 -40351	D30A8 -40811	D30A8 -40611	D30A8 -42011	HRLH1634011 -59	
250	-40421	-40221	-40821	-40621	-42021	-69	
270	-40431	-40231	-40831	-40631	-42031	-73	
300	-40401	-40201	-40801	-40601	-42001	-79	标准 (STD)
330	-40441	-40241	-40841	-40641	-42041	-85	
350	-40451	-40251	-40851	-40651	-42051	-89	
370	-40461	-40261	-40861	-40661	-42061	-93	
400	-40471	-40271	-40871	-40671	-42071	-99	
425	-40481	-40281	-40881	-40681	-42081	-105	
450	-40491	-40291	-40891	-40691	-42091	-109	
475	-40511	-40311	-40911	-40711	-42101	-115	
500	-40521	-40321	-40921	-40721	-42141	-119	
550	-40531	-40331	-40931	-40731	-42121	-131	
600	-40541	-40341	-40941	-40741	-42131	-141	

图133/FIG133

前起升油缸(二级全自由)/FRONT LIFT CYLINDER(FULL FREE 2-STAGE MAST ZM)

H14

序号 Item No	图号 Part No	零部件名称 Description	件数 Q'ty	备注 Remark
A	REF103316G	Lift cylinder (front) (Inc.01~13,18,22~24)	前升降缸 1	2t,2.5t 见选用件表 See op.parts
-	REF480010	Lift cylinder (front) (Inc.01~13,18,22,23)	前升降缸 1	3t 见选用件表 See op.parts
01	23650-82402	Cap, lift cylinder	前缸盖 1	2t, 2.5t
-	64460-48201a	Cap, lift cylinder	前缸盖 1	3t
02	REF339093 23650-82111	Dust ring	防尘圈75 1	2t, 2.5t
-	REF339093 24450-82231	Dust ring	防尘圈85 1	3t
03	REF340213 23650-82121	Yx-ring seal	Yx密封圈d75 1	2t, 2.5t
-	REF340213 24450-82241	Yx-ring seal	Yx密封圈d85 1	3t
04	23650-82131	Snap ring	挡圈 1	2t, 2.5t
-	25908-42471	Snap ring	挡圈(一) 1	3t
05	Z6004-10003	O-ring seal	O型密封圈100X3.1 1	GB1235-76 2t, 2.5t
-	64460-00002G	O-ring seal	O型密封圈 1	3t
06	23650-82141	Snap ring	挡圈 1	2t, 2.5t
-	REF340216 24450-82281	Snap ring	挡圈(二) 1	3t
07	22518-40151	Plug	螺塞 2	
08	22438-42641	Wearing	支承环 1	2t, 2.5t
-	REF340369 23878-52101	Wearing	支承环 1	3t
09	B1830-06010	Screw	螺钉M6X10 2	GB80-85 2t, 2.5t
-	B1830-06008	Screw	螺钉M6X8 2	GB80-85 3t
10	90662-63401G	Plug	塞子 2	
11	REF341084 53658-42011	Seal ring	密封环90X82.4X4.5 1	2t, 2.5t
-	REF341084 54458-42011	Seal ring	密封环100X92.4X4.3 1	3t
12	REF209336	Piston rod ass'y	柱塞杆总成 1	2t,2.5t 见选用件表 See op.parts
-	REF481010	Piston rod ass'y	柱塞体 1	3t 见选用件表 See op.parts
13	REF207154G	Cylinder body(front)	前缸体 1	2t,2.5t 见选用件表 See op.parts
-	REF482010	Cylinder body(front)	前缸体 1	3t 见选用件表 See op.parts
14	B0230-16080	Bolt	螺栓M16X80 1	GB5782-86
15	B5050-00016	Washer, lock	垫圈16 1	GB93-87
16	23650-82501	Sheave seat	链轮座 1	
17	20028-00280	Stopper, chain	护链板 1	

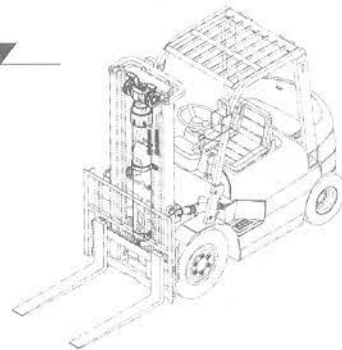
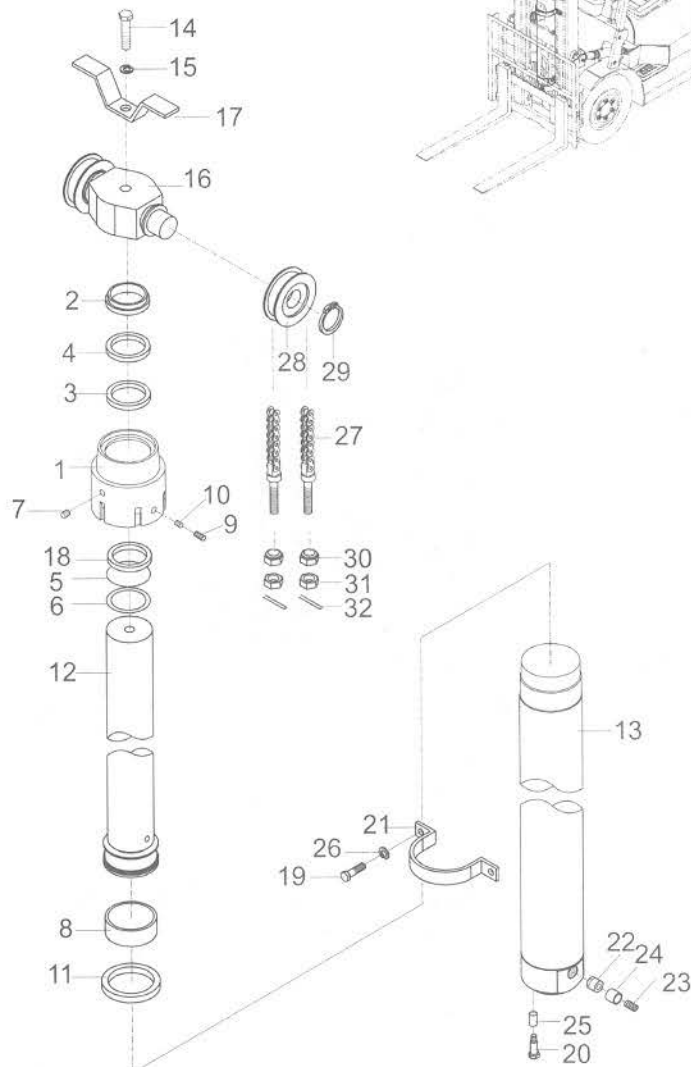
CPQ,CPQD20,25,30
CPC,CPCD20,25,30

H

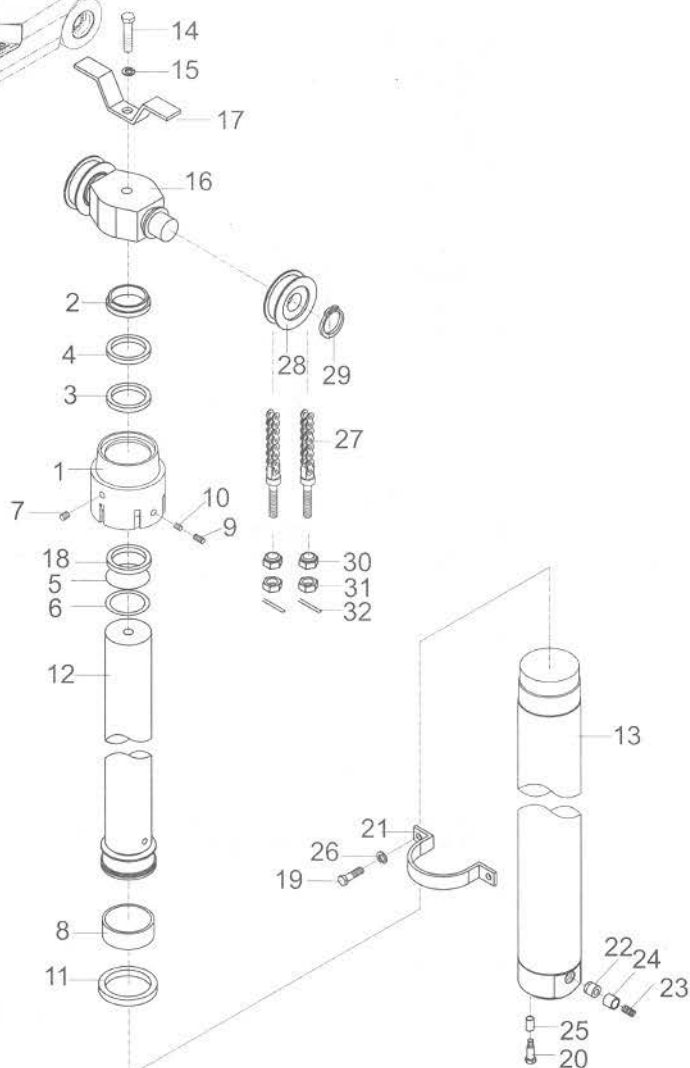
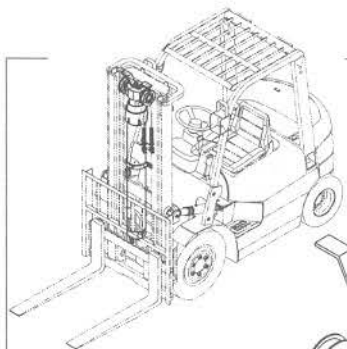

CPC, CPCD20,25,30
CPQ, CPQD20,25,30

序号 Item No	图号 Part No	零部件名称 Description	件数 Q'ty	备注 Remark
18	GS-1	Bushing	1	钢背轴承7530 2t, 2.5t
-	Z2111-08540	Bushing	1	钢背轴承8540 3t
19	B0530-10020	Bolt	2	螺栓M10X1.25X20 GB5786-86
20	B0530-10030	Bolt	1	螺栓M12X1.25X30
21	D20L0-54011	Support	1	固定卡 2t, 2.5t
-	D20Q0-72101	Support	1	固定卡 3t
22	23650-82371A	Spool	1	阀芯 2t, 2.5t
-	20030-48341	Spool	1	阀芯 3t
23	REF339431 24230-52701	Spring	1	弹簧 2t, 2.5t
-	24389-46021	Spring	1	弹簧 3t
24	24230-82071	Seat, spring	1	弹簧座 2t, 2.5t
25	D10P0-22001	Spacer	1	隔套
26	B5050-00010	Washer, lock	2	垫圈10 GB93-87
27	HRLH1234021	Chain ass'y (Inc.30~32)	2	链条总成 2t, 2.5t 见选用件表 See op.parts
-	HRLH1623011	Chain ass'y (Inc.30~32)	2	链条总成 3t 见选用件表 See op.parts
28	23659-44842	Sheave	2	链轮
29	B6150-00040	Snap ring	2	挡圈40 GB894.1-86
30	22198-40192G	Nut	4	螺母
31	B4230-00018	Nut	4	螺母M18x1.5 GB6171-86
32	B3010-03030	Pin	4	开口销3x30 GB91-86

图133/FIG133

前起升油缸(二级全自由)/FRONT LIFT CYLINDER(FULL FREE 2-STAGE MAST ZM)

H14

2, 2.5t前起升缸选用件(二级全自由门架)
OPTIONAL PARTS 2/2.5 TON FRONT LIFT CYLINDER (FULL FREE 2-STAGE MAST)

起升高度 LIFTING HEIGHT	前升降缸 LIFT CYLINDER	柱塞杆总成 POSTION ROD ASS 'Y	前缸体 CYLINDER BODY	链条总成 CHAIN ASS' Y	备注 REMARKS
ZM	22679	23650	23650	HRLH1234021	
200	-45591	-50411	-50212G	-59	
225	-45671	-50421	-50222G	-67	
250	-45671	-50431	-50232G	-67	
270	-45711	-50441	-50242G	-71	
275	-45691	-50451	-50252G	-69	
300	-45751	-50401	-50202G	-75	标准(STD)
325	-45831	-50461	-50262G	-83	
330	-45831	-50471	-50272G	-83	
350	-45891	-50481	-50282G	-89	
366	-45931	-50491	-50292G	-93	
370	-45951	-50501	-50302G	-95	
375	-45951	-50511	-50312G	-95	
400	-46051	-50521	-50322G	-105	
425	-46111	-50531	-50332G	-111	
450	-46171	-50541	-50342G	-117	
475	-46251	-50551	-50352G	-125	
500	-46311	-50561	-50362G	-131	
550	-46471	-50571	-50372G	-145	
600	-46591	-50581	-50382G	-159	

CPQ,CPQD20,25
CPC,PCPD20,25

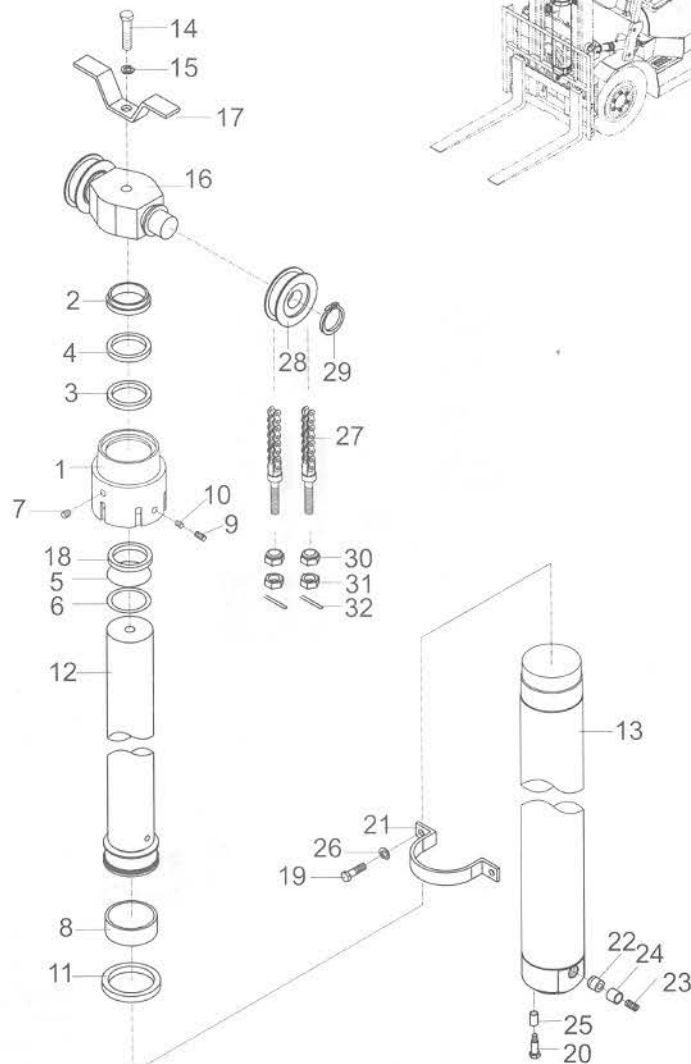

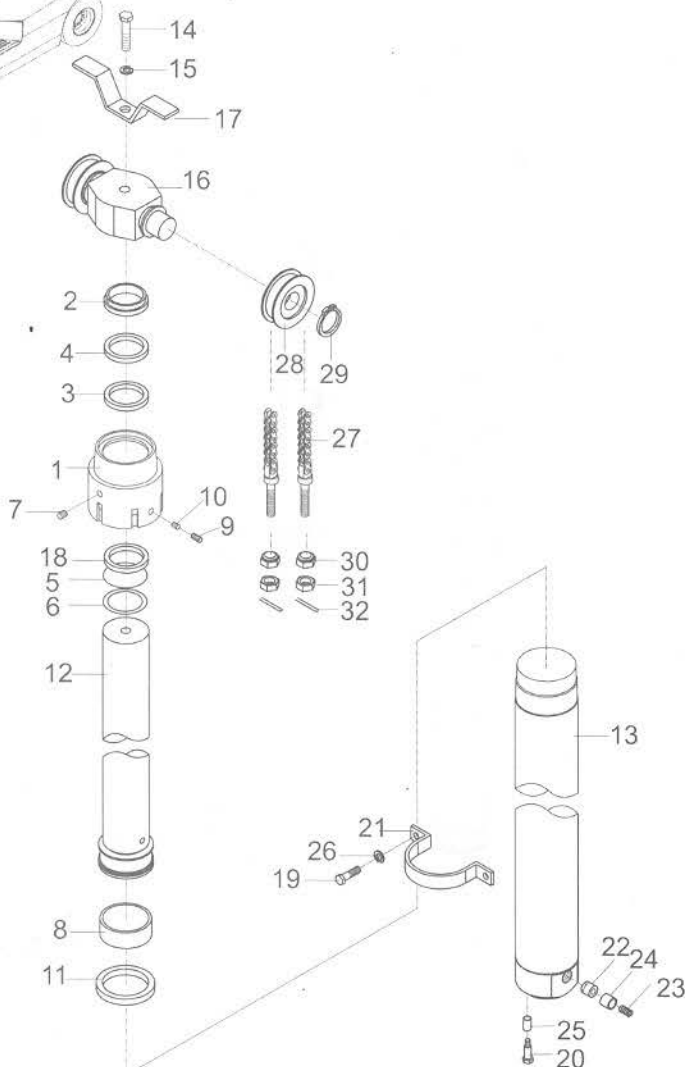
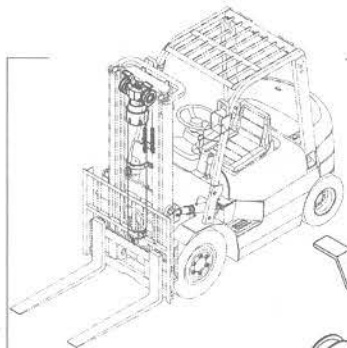

3t前起升缸选用件(二级全自由门架)
OPTIONAL PARTS 3 TON FRONT LIFT CYLINDER (FULL FREE 2-STAGE MAST)

起升高度 LIFTING HEIGHT	前升降缸 LIFT CYLINDER	柱塞体 POSITION ROD ASS'Y	前缸体 CYLINDER BODY	链条总成 CHAIN ASS'Y	备注 REMARKS
ZM 200	20038-80010	20038-84010	20038-82010	HRLH1623011-47	
225	-80020	-84020	-82020	-49	
250	-80030	-84030	-82030	-51	
270	-80040	-84040	-82040	-55	
275	-80050	-84050	-82050	-57	
300	-80000	-84000	-82000	-59	标准 (STD)
325	-80060	-84060	-82060	-63	
330	-80070	-84070	-82070	-65	
350	-80080	-84080	-82080	-69	
366	-80090	-84090	-82090	-71	
370	-80100	-84100	-82100	-73	
375	-80110	-84110	-82110	-73	
400	-80120	-84120	-82120	-81	
425	-80130	-84130	-82130	-85	
450	-80140	-84140	-82140	-91	
475	-80150	-84150	-82150	-95	
500	-80160	-84160	-82160	-101	
550	-80170	-84170	-82170	-113	
600	-80180	-84180	-82180	-123	

图134/FIG134

前起升油缸(二级全自由)/FRONT LIFT CYLINDER(FULL FREE 2-STAGE MAST ZM)

H15

序号 Item No	图号 Part No	零部件名称 Description	件数 Q'ty	备注 Remark
A	HRD30K0501	Front lift cylinder (inc.16~31) 前起升油缸	1	
01	D30K0-50211	Sheave seat 链轮座	1	
02	HRLH1634011-N	Chain ass'y (Inc.13-15) 链条总成(包含13-15)	2	见选件表 See Op. Parts
03	D20B8-42031	Spacer 隔套	1	
04	B0532-12035	Bolt 螺栓M12X1.25X35	1	GB5788-86
05	B0532-10020	Bolt 螺栓M10X1.25X20	2	GB5786-86
06	B5052-00010	Washer 垫圈10	2	GB93-87
07	D30K0-52031	Support 固定卡	1	
08	B6152-00040	Snap ring 挡圈40	2	GB894.1-86
09	24609-41241	Sheave 链轮	2	
10	B5052-00016	Washer 垫圈16	1	GB93-87
11	B0230-16070	Bolt 螺栓M16X70	1	GB5782-86
12	D30K0-52021	Stopper,chain 护链板	1	
13	B3010-02540	Pin 销2.5X40	2	GB91-86
14	B4230-00022	Nut 螺母M22X1.5	2	GB6171-86
15	23818-30271	Nut 球形螺母	2	
B	HRD30K0501	Front lift cylinder 前起升缸	1	见选件表 See Op. Parts
16	HRD30K0502	Piston rod ass'y 柱塞杆总成	1	见选件表 See Op. Parts
17	D30K0-52501	Dust ring 防尘圈ME-3 95	1	
18	D30K0-52511	Yx-ring Yx密封圈D2 95	1	
19	D30K0-52521	Snap ring 挡圈I	1	
20	Q/ZB223.2	Plug 螺塞Z1/4"	1	
21	ORAR00350-N90	O-ring O型密封圈116.84X5.33	1	
22	D30K0-52531A	Cap, lift cylinder 前缸盖	1	
23	HRD30K0503	Front lift cylinder body 前缸体	1	见选件表 See Op. Parts
24	D30K0-52541	Wearing 支承环	1	
25	D30K0-52551	Seal 密封环	1	
26	REF339431 24389-46021	Spring 弹簧	1	
27	D30K0-52561	Valve 滑阀	1	
28	90662-63401G	Plug 塞子	1	

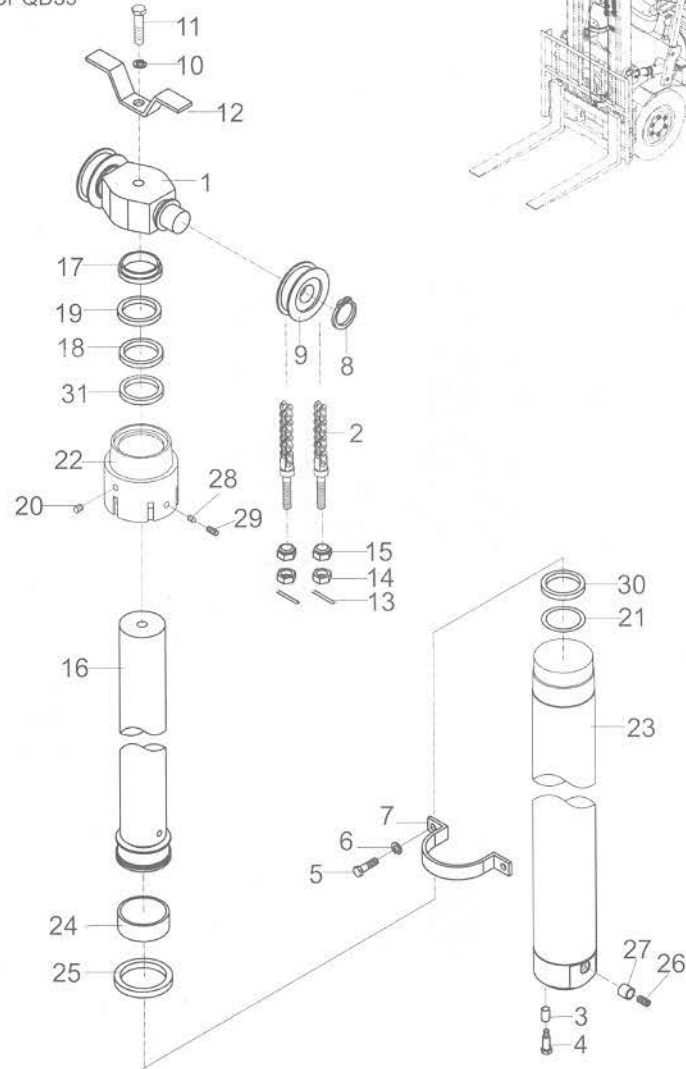
CPC, CPCD35
CPQ, CPQD35

h2000

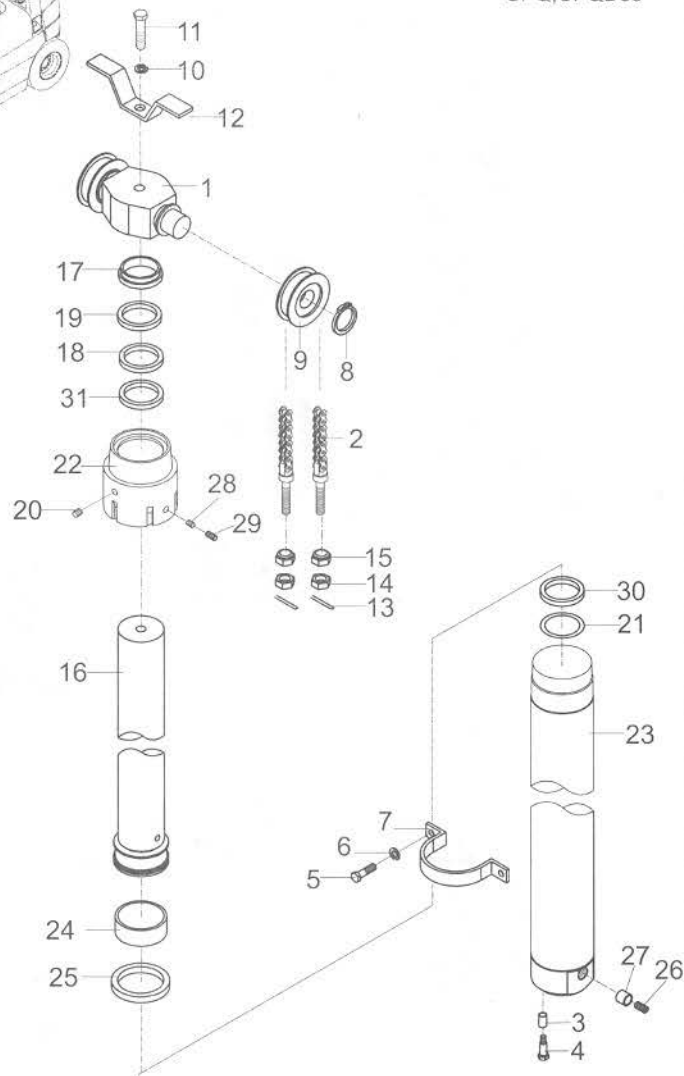
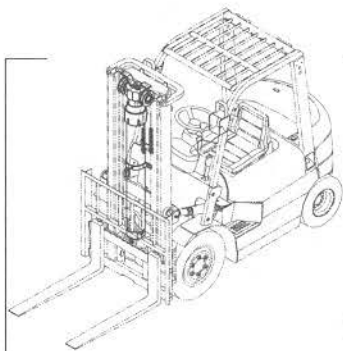

CPC,CPD35
CPQ,CPQD35

序号
Item
No

图号
Part No

零部件名称
Description

件数
Q'ty

备注
Remark

29	B1830-06010	Screw	螺钉M6X10	1	GB80-76
30	D30K0-52571	Snap ring	挡圈II	1	
31	Z2113-09535	Bushing	钢背轴承09535	1	

前起升油缸用件 OPTION TABLE FOR LIFT CYLINDER

起升高度 LIFTING HEIGHT	前起升油缸 LIFT CYL.	前缸体 LYL. BODY	柱塞杆总成 RID. PISTON	链条节数(N) CHAIN. LEAF
ZM200	HRD30K0501 D30K0-50411	HRD30K0503 D30K0-50721	HRD30K0502 D30K0-50561	HRLH1634011 -53
250	-50421	-50731	-50571	-63
270	-50431	-50741	-50581	-65
标准 (STD)	300 -50401	-50751	-50591	-69
330	-50441	-50761	-50611	-75
350	-50451	-50771	-50621	-79
370	-50461	-50781	-50631	-83
400	-50471	-50791	-50641	-89
425	-50481	-50811	-50651	-95
450	-50511	-50821	-50661	-101
475	-50521	-50831	-50671	-105
500	-50531	-50841	-50681	-111
550	-50541	-50851	-50691	-123
600	-50551	-50861	-50711	-133

CPC, CPCD35
CPQ, CPQD35

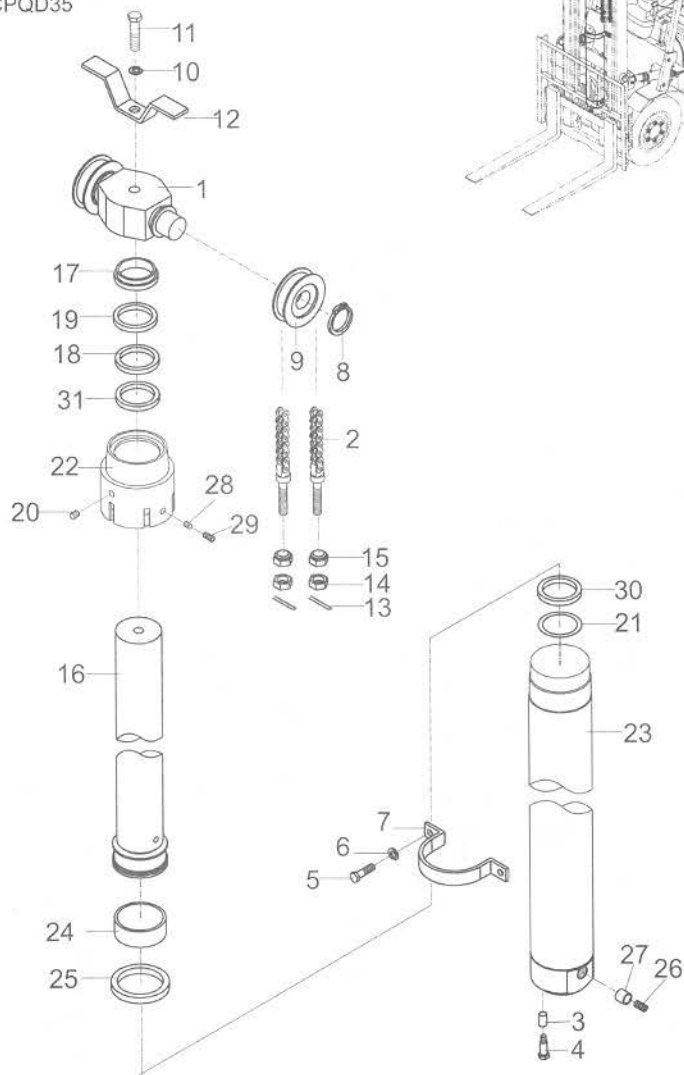

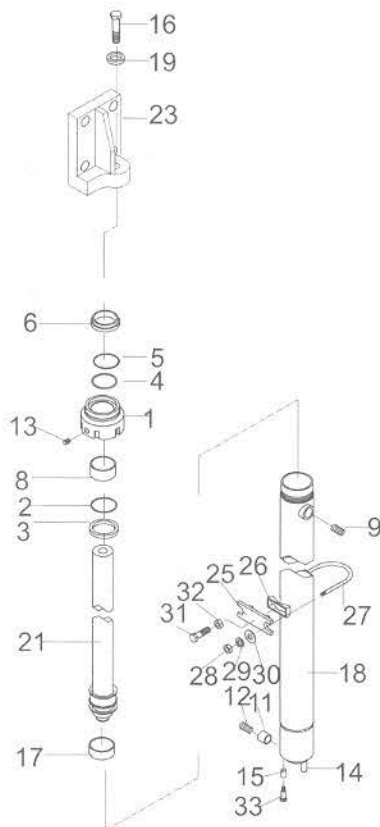
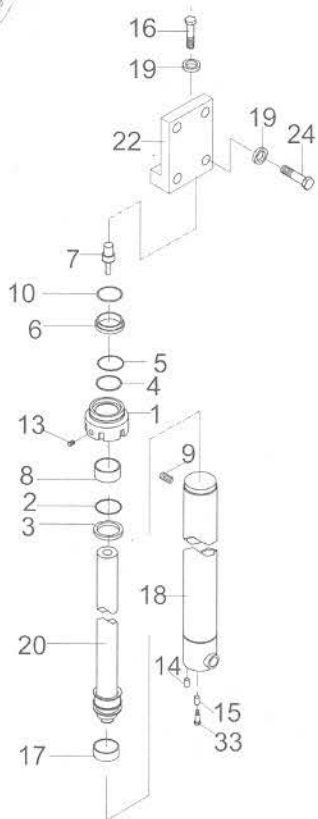
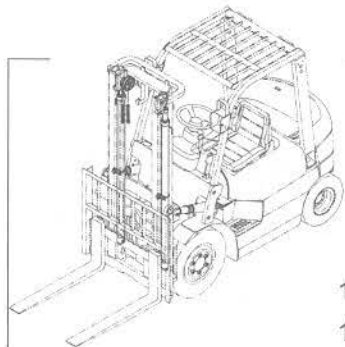

CPC, CPCD20, 25, 30
CPQ, CPQD20, 25, 30

序号 Item No	图号 Part No	零部件名称 Description	件数 Qty	备注 Remark
A	REF104794G	Lift cylinder (rear) (Inc.1~14,17,18,20,21)	后升降油缸	1 2t, 2.5t
-	REF200330	Lift cylinder (rear) (Inc.1~14,17,18,20,21)	后升降油缸	1 3t
01	23650-52831G	Cap. cylinder	缸盖	2 2t, 2.5t
-	20038-36500	Cap. cylinder	缸盖	2 3t
02	23650-52911	O-ring seal	O型密封圈	2 2t, 2.5t
-	Z6003-06003	O-ring seal	O型密封圈60 X3.1	2 GB1235-76 3t
03	23650-52881	Snap ring	挡圈	2 2t, 2.5t
-	20030-52881	Snap ring	挡圈	2 3t
04	REF340213 23650-52851	Yx-ring seal	Yx型密封圈d35	2 2t, 2.5t
-	FU0497K0	Yx-ring seal	Yx型密封圈d40	2 3t
5	23650-52861	Snap ring	挡圈	2 2t, 2.5t
-	REF340216 23650-83531	Snap ring	挡圈	2 3t
06	REF339093 23650-52871 REF339093	Dust ring	防尘圈35	2 2t, 2.5t
-	23650-83581	Dust ring	防尘圈40	2 3t
7	20020-10450A	Joint rod	连接杆	1
8	Z2113-04030	Bushing	钢背轴承4030	2 GS-1
9	B1830-06010	Screw	螺钉M6X10	4 GB80-85
-	90662-63401G	Plug	塞子	4 ONLY FOR 3t
10	Z6004-02602	O-ring seal	O型密封圈26X2.4	1 GB1235-76
11	23650-82371	Spool	阀芯	1
12	27978-42601	Spring	弹簧	1
13	Q/ZB223.1	Plug	螺塞Z1/8"	4
14	B3120-10025	Pin	销10X25	2 GB119-86 2t, 2.5t
-	B3120-10024	Pin	销10X24	2 GB119-86 3t
15	HRD20B8407 D20B8-42031	Spacer	隔套	2
16	B0530-16035	Bolt	螺栓M16X1.5X35	2 GB5786-86
17	22580-53321G	Wearing	支承环	2 2t, 2.5t
-	REF340369 27970-53141	Wearing	支承环	2 3t
18	REF104420G	Cylinder body(L.H. &R.H.)	缸体(左右各一)	2 2t, 2.5t
-	REF200360	Cylinder body(L.H. &R.H.)	缸体(左右各一)	2 3t

图135/FIG135

后起升油缸(二级全自由)/REAR LIFT CYLINDER(FULL FREE 2-STAGE MAST ZM)

H16

序号 Item No	图号 Part No	零部件名称 Description	件数 Q'ty	备注 Remark
19	B5050-00016	Washer, lock 垫圈16	10	GB93-87
20	REF207961	Piston rod ass'y ,R.H. 右柱塞杆总成	1	2t, 2.5t
-	REF200370	Piston rod ass'y ,R.H. 右柱塞杆总成	1	3t
21	REF208213	Piston rod ass'y ,L.H. 左柱塞杆总成	1	2t, 2.5t
-	REF200340	Piston rod ass'y ,L.H. 左柱塞杆总成	1	3t
22	HRD20L0503 D20L0-50301	Bracket, R.H. 支架(右)	1	2t, 2.5t
-	HRD20L0503 D28L0-50301	Bracket, R.H. 支架(右)	1	3t
23	HRD20L0503 D20L0-50201	Bracket, L.H. 支架(左)	1	2t, 2.5t
-	HRD20L0503 D28L0-50201	Bracket, L.H. 支架(左)	1	3t
24	B0330-16040	Bolt 螺栓M16X40	8	GB5783-86
25	D20B8-42041	Support 油缸支撑块	2	
26	D20B8-42051	Rubber 调整块	2	
27	HRD20B8408 D20B8-42061	U-bolt U型螺栓	2	
28	B4413-00010	Nut 螺母M10X1.25	4	GB6173-86
29	B5050-00010	Washer, lock 垫圈10	4	GB93-87
30	B5310-00010	Washer 垫圈10	4	GB97.1-85
31	B0530-12040	Bolt 螺栓M12X1.25X40	2	GB5786-86
32	B4116-00012	Nut 螺母M12X1.25	2	GB6170-86
33	B0530-12025	Bolt 螺栓M12X1.25X25	2	GB5786-86

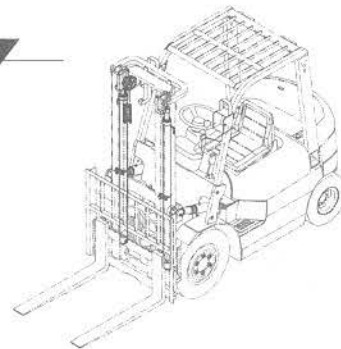
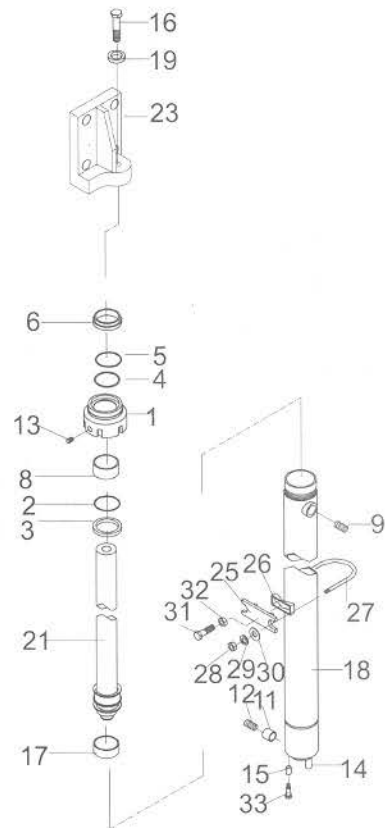
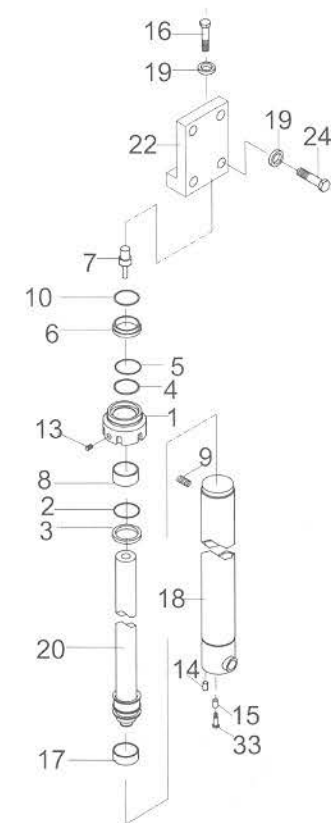

CPC, CPCD20, 25
CPQ, CPQD20, 25

2-2.5t叉车后起升油缸选配件 (二级全自由门架)
REAR LIFT CYLINDER OPTIONAL PARTS (FULL FREE 2-STAGE MAST)

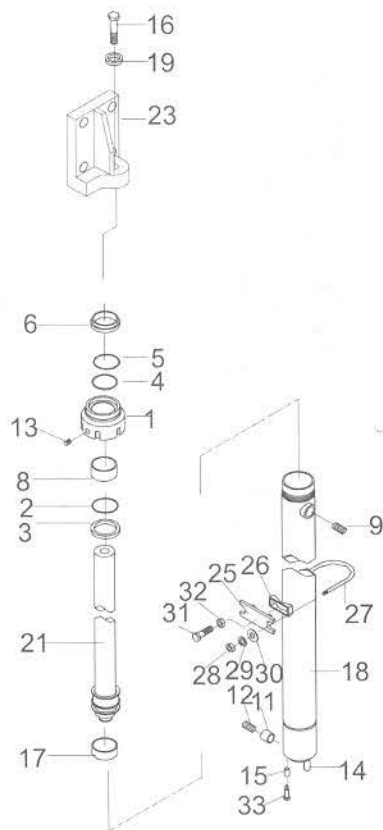
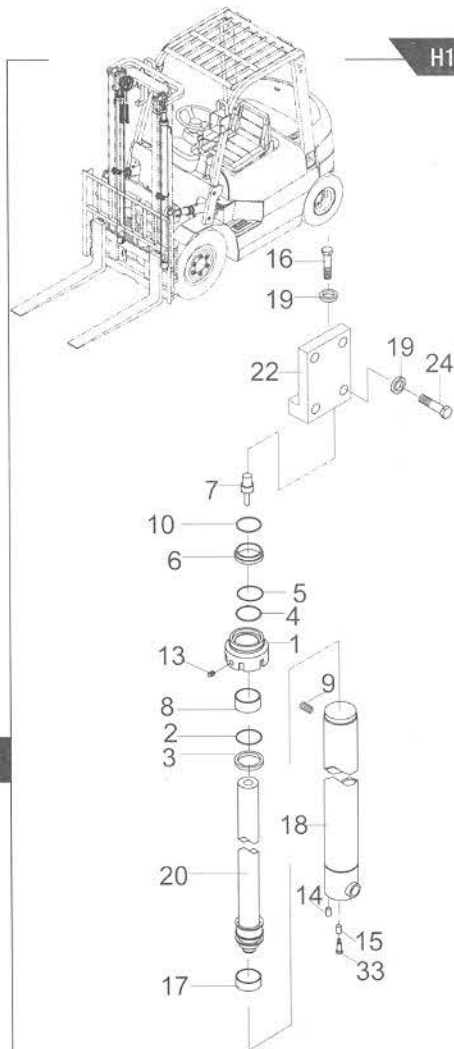

起升高度 IFTING HEIGHT	后起升油缸 LIFT CYLINDER (REAR)		缸体 CYLINDER BODY		右柱塞杆总成 PISTON ROD ASS' Y. R. H.	左柱塞杆总成 PISTON ROD ASS' Y. L. H.	备注 REMARK
	左 (LEFT)	右 (RIGHT)	左 (LEFT)	右 (RIGHT)			
ZM	23670	23670	24240	24240	23670	23670	
200	-50011	-50211	-50411	-50611	-50811	-51011	
225	-50021	-50221	-50421	-50621	-50821	-51021	
250	-50031	-50231	-50431	-50631	-50831	-51031	
270	-50041	-50241	-50441	-50641	-50841	-51041	
275	-50051	-50251	-50451	-50651	-50851	-51051	
300	-50001	-50201	-50401	-50601	-50801	-51001	标准 (STD)
325	-50061	-50261	-50461	-50661	-50861	-51061	
330	-50071	-50271	-50471	-50671	-50871	-51071	
350	-50081	-50281	-50481	-50681	-50881	-51081	
366	-50091	-50291	-50491	-50691	-50891	-51091	
370	-50101	-50301	-50501	-50701	-50901	-51101	
375	-50111	-50311	-50511	-50711	-50911	-51111	
400	-50121	-50321	-50521	-50721	-50921	-51121	
425	-50131	-50331	-50531	-50731	-50931	-51131	
450	50141	-50341	-50541	-50741	-50941	-51141	
475	-50151	-50351	-50551	-50751	-50951	-51151	
500	-50161	-50361	-50561	-50761	-50961	-51161	
550	-50171	-50371	-50571	-50771	-50971	-51171	
600	-50181	-50381	-50581	-50781	-50981	-51181	

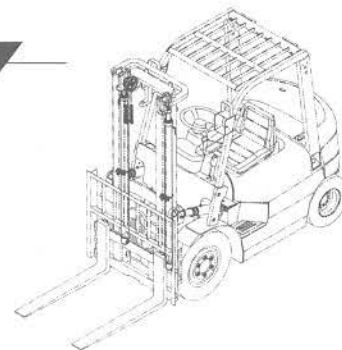

3t叉车后起升油缸选用件(二级全自由门架)
REAR LIFT CYLINDER OPTIONAL PARTS (FULL FREE 2-STAGE MAST)

起升高度 LIFTING HEIGHT	后起升油缸 LIFT CYLINDER (REAR)		缸体 CYLINDER BODY		右柱塞杆总成 PISTON ROD ASS'Y, R. H.	左柱塞杆总成 PISTON ROD ASS'Y, L. H.	备注 REMARK
	左(LEFT)	右(RIGHT)	左(LEFT)	右(RIGHT)			
ZM	20030	20030	20036	20036	20036	20036	
200	-50210	-50010	-31010	-41010	-17010	-26010	
225	-50220	-50020	-31020	-41020	-17020	-26020	
250	-50230	-50030	-31030	-41030	-17030	-26030	
270	-50240	-50040	-31040	-41040	-17040	-26040	
275	-50250	-50050	-31050	-41050	-17050	-26050	
300	-50200	-50000	-31000	-41000	-17000	-26000	标准 (STD)
325	-50260	-50060	-31060	-41060	-17060	-26060	
330	-50270	-50070	-31070	-41070	-17070	-26070	
350	-50280	-50080	-31080	-41080	-17080	-26080	
366	-50290	-50090	-31090	-41090	-17090	-26090	
370	-50300	-50100	-31100	-41100	-17100	-26100	
375	-50310	-50110	-31110	-41110	-17110	-26110	
400	-50320	-50120	-31120	-41120	-17120	-26120	
425	-50330	-50130	-31130	-41130	-17130	-26130	
450	-50340	-50140	-31140	-41140	-17140	-26140	
475	-50350	-50150	-31150	-41150	-17150	-26150	
500	-50360	-50160	-31160	-41160	-17160	-26160	
550	-50370	-50170	-31170	-41170	-17170	-26170	
600	-50380	-50180	-31180	-41180	-17180	-26180	

CPQ,CPQD30
CPC,CPCD30

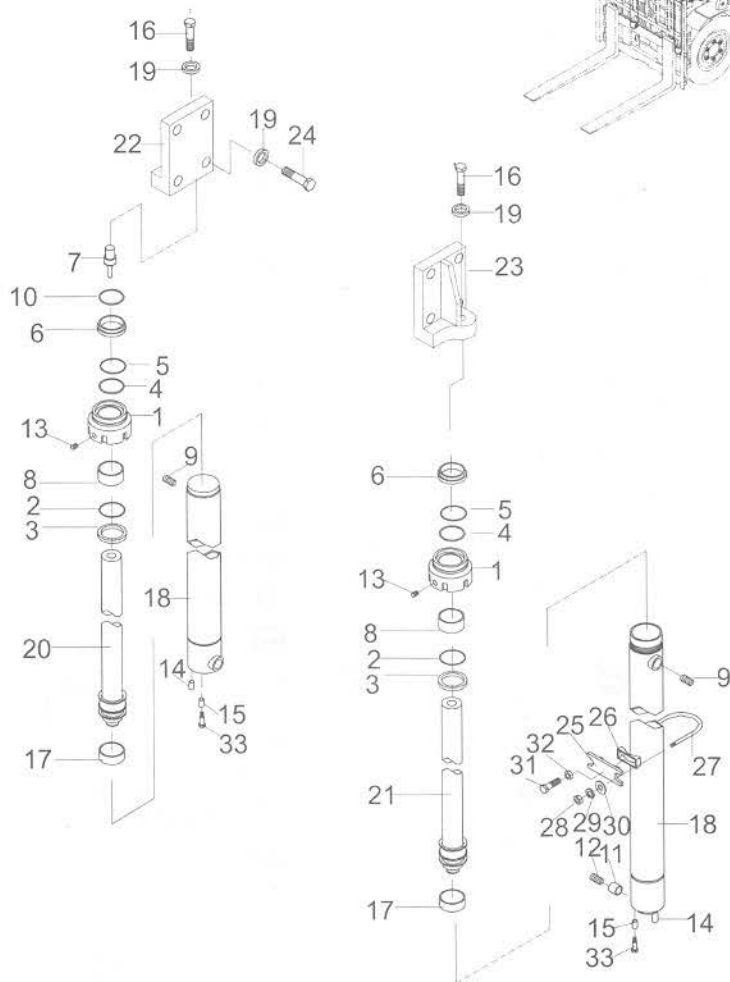

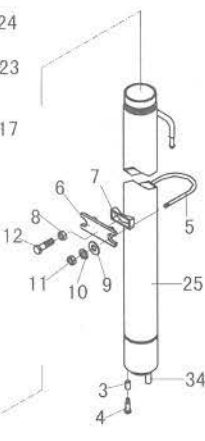
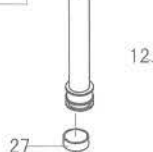
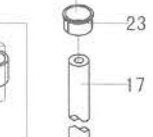
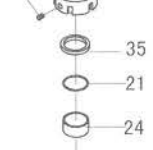
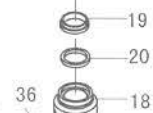
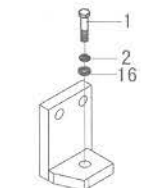
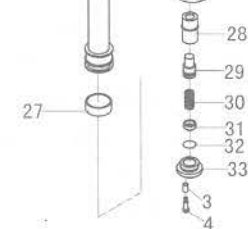
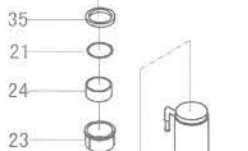
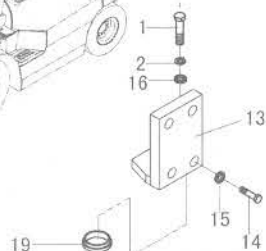
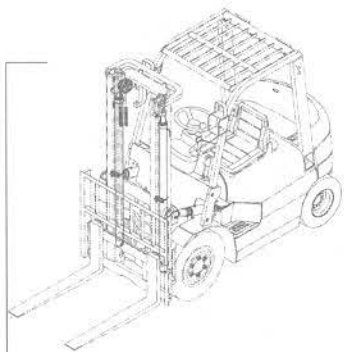
CPC, CPCD35
CPQ, CPQD35

序号 Item No	图号 Part No	零部件名称 Description	件数 Q'ty	备注 Remark
A	HRD30K0510	Lift cylinder rear (Inc.17~36)	后起升油缸	2
01	B5052-00016	Washer,lock	垫圈16	2 GB93-87
02	B0332-16035	Bolt	螺栓M16X35	4 GB5783-86
03	B0430-12030	Bolt	螺栓M12X1.25X30	2 GB5785-86
04	HRD20B8407 D20B8-42031	Sleeve	隔套	2
05	HRD20B8404 D28B8-42521	U-bolt	U型螺栓	2
06	D20B8-42041	Support	油缸支承块	2
07	D20B8-42051	Spacer	调整块	2
08	B4218-00010	Nut	螺母M10X1.25	4 GB6171-86
09	B5311-00010	Washer	垫圈10	4 GB97.1-85
10	B5052-00010	Washer,lock	垫圈10	4 GB93-87
11	B4218-00012	Nut	螺母M12X1.25	2 GB6171-86
12	B0520-12040	Bolt	螺栓M12X1.25X40	2 GB5786-86
13	D30K0-40291	Bracket	支架	2
14	B0332-18045	Bolt	螺栓M18X45	4 GB5783-86
15	B5052-00018	Washer,lock	垫圈18	4 GB93-87
16	D30K0-42061	Shim	调整垫片	4
B	HRD30K0510	Lift cylinder,back	后起升油缸	2 见选用件表 See op. Parts
17	HRD30K0511	Piston R.H.	活塞杆总成(右)	1 见选用件表 See op. Parts
-	HRD30K0512	Piston L.H.	活塞杆总成(左)	1 见选用件表 See op. Parts
18	D30K8-54024	Cap	导向套	2
19	HRF339093 24459-42271	Seal	防尘圈d45	2
20	HRD20B8406 D28B8-42611	U-ring	U型密封圈D40	2
21	Z6003-06803	O-ring	O型密封圈53X2.65	2
22	D20B8-42341	Plug	塞子	2
23	H26A8-42011	Sleeve	衬套	2
24	D28B8-42461	Bushing	钢背轴承	2
25	HRD30K0514	Cylinder R.H.	缸体(右)	1 见选用件表 See op. Parts
-	HRD30K0513	Cylinder L.H.	缸体(左)	1 见选用件表 See op. Parts
26	HRD30K0515	Spacer	调整套	2 见选用件表 See op. Parts

图136/FIG136

后起升油缸(二级全自由)/REAR LIFT CYLINDER(FULL FREE 2-STAGE MAST ZM)

H17

序号 Item No	图号 Part No	零部件名称 Description	件数 Qty	备注 Remark
27	REF340369 27978-42421	Wearing	2	
28	H22N0-87041	Sleeve	1	
29	H22N0-87051	Poppet	1	
30	REF339431 53658-43031	Spring	1	
31	H22N0-87061	Spring seat	1	
32	Z6004-04003	O-ring	1	GB1235-76
33	H22N0-87071	Seat	1	
34	B3130-10026	Pin	1	GB119-86
35	D30K8-54011	Snap ring	1	
36	Q/ZB223.2	Plug	2	

CPC, CPCD35
CPQ, CPQD35

图 137/FIG137

倾斜油缸/TILT CYLINDER

H18

序号 Item No	图号 Part No	零部件名称 Description	件数 Q'ty	备注 Remark
A	HRH22N8501	Tilt cylinder	倾斜油缸	见选用件表 See op.parts
01	D20B8-52011	Ear ring	耳环	2
02	23658-52101	Shim	垫片	12
03	23658-52401	Plug	塞子	2
04	B1830-10010	Screw	螺钉M10X10	2 GB80-85
05	HRD20B8502	Spacer	调整轴套	见选用件表 See op.parts
06	REF341310 23468-52081	Seal,dust	防尘圈	2
07	B6050-00052	Ring,snap	挡圈52	2 GB893.1-85
08	D20B8-52021	Guide sleeve	导向套	2
09	23678-54021	Ring,snap	挡圈	2
10	REF340216 23678-54001	Shim	挡片d32	2
11	REF340213 22228-50153A	U-ring	U型密封圈d32	2
12	Z6003-07003	O-ring	O型密封圈70X3.1	2 GB1235-76
13	REF340270 23678-54012	Bushing	轴套	2
14	D20B8-50201	Body,piston ass'y	活塞体总成	2
15	HRH22N8502 H22N8-50221	Tube,cylinder ass'y R.H.	缸筒总成(右)	2
-	HRH22N8502 H22N8-50231	Tube,cylinder ass'y L.H.	缸筒总成(左)	2
16	REF340214 23678-55001	Yx-ring	Yx密封圈D70	4
17	REF341311 23678-52051	Wearing	支承环	2
18	REF340270 63626-23071	Bushing	轴套	2
19	Z2500-01010	Fitting grease	油杯M10X1	2
20	B6050-00047	Ring,snap	挡圈47	2
21	D20B8-50211	Bushing	关节轴承	2
22	B0230-14055	Bolt	螺栓M14X55	2 GB5782-86
23	B4123-00014	Nut	螺母M14	2 GB6170-86
24	B5050-00014	Washer,lock	垫圈14	2 GB93-87
25	H22A8-00201	Pin	倾斜缸销轴	2
26	B5052-00010	Washer,lock	垫圈10	2 GB93-87
27	B0530-10020	Bolt	螺栓M10X1.25X20	2 GB5786-86

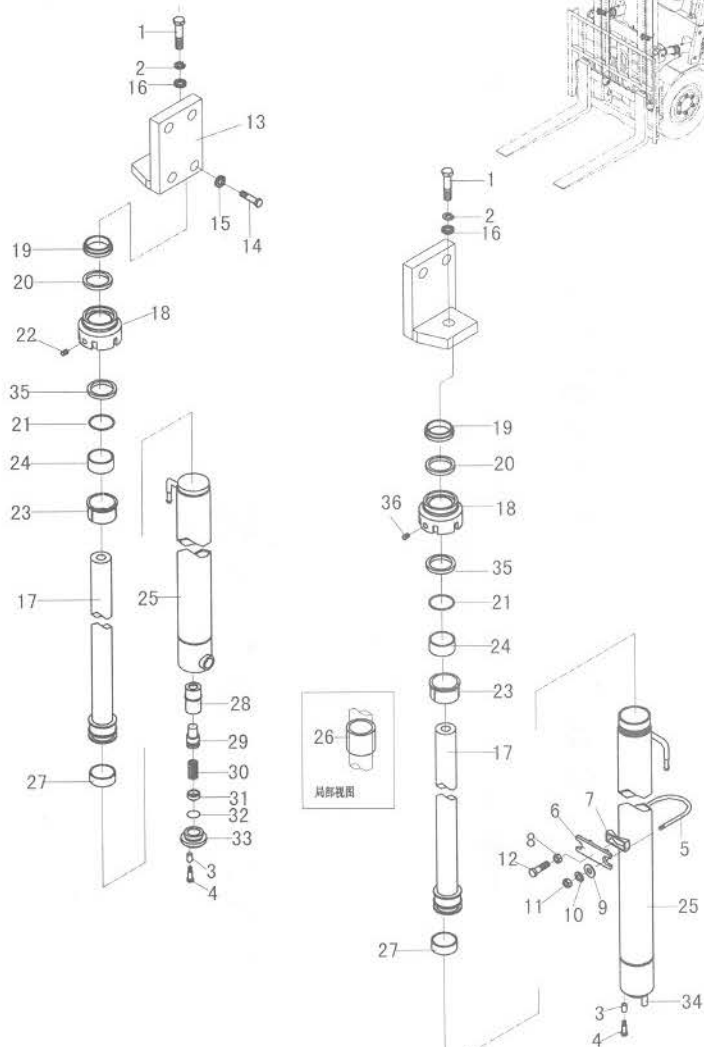
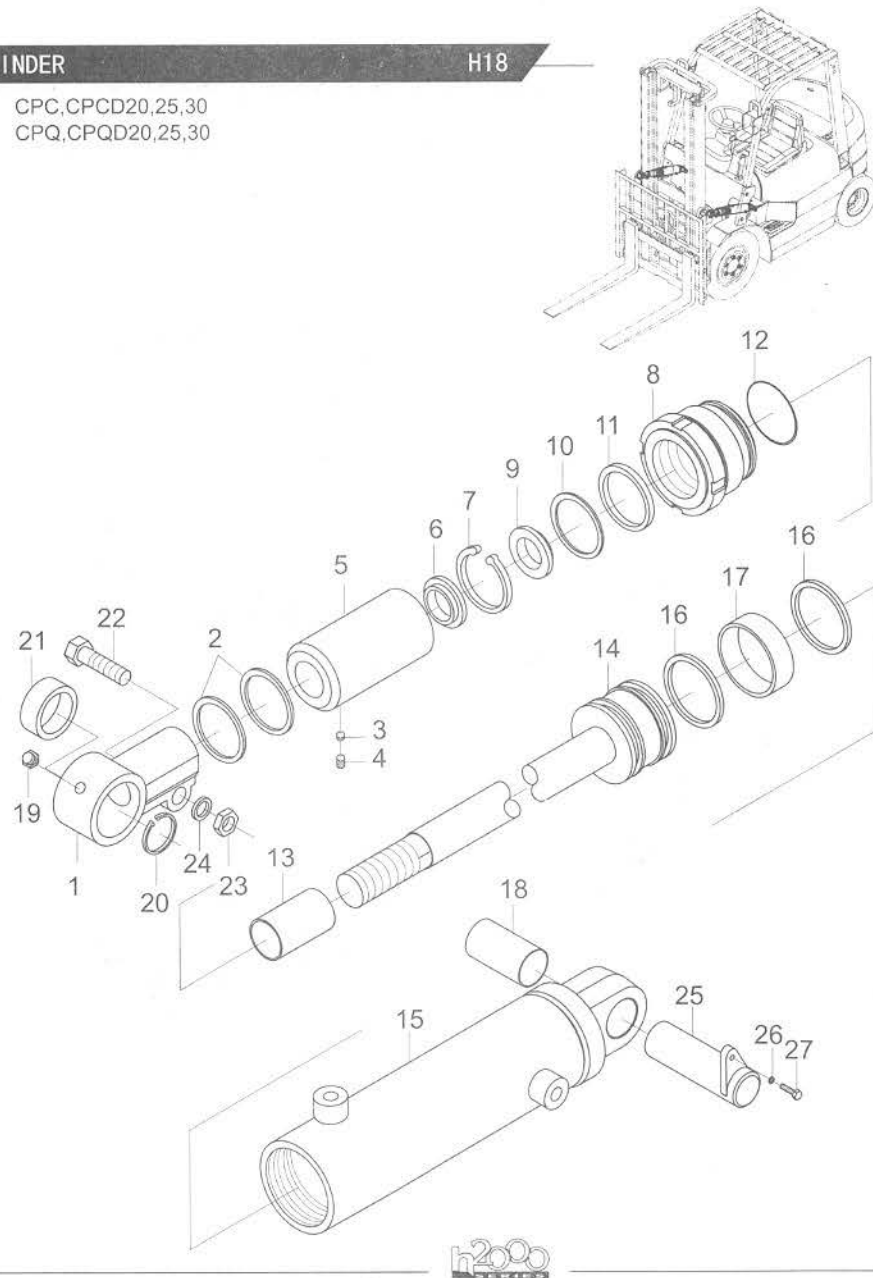

H

图138/FIG138

倾斜油缸/TILT CYLINDER

H19

序号 Item No	图号 Part No	零部件名称 Description	件数 Qty	备注 Remark	CPC,CPD35 CPQ,CPQD35
A	HRD05A8501	Tilt cylinder	倾斜油缸	2	见选用件表 See op.parts
01	D30A8-52011	Ear ring	耳环	2	
02	23658-52101	Shim	垫片	12	
03	23658-52401	Plug	塞子	2	
04	B1830-10010	Screw	螺钉M10X10	2	GB80-85
05	HRD30A8502	Spacer	调整轴套	2	见选用件表 See op.parts
06	REF339093 23650-52871	Seal,dust	防尘圈	2	
07	REF340216 24230-82221	Ring,back-up	挡圈	4	
08	D30A8-52021	Guide sleeve	导向套	2	
09	B5050-00010	Washer,lock	垫圈10	2	GB93-87
10	23650-52861	Ring,back-up	挡圈	2	
11	D30A8-53001	U-ring	U型密封圈35X45X10	2	
12	Z6003-08003	O-ring	O型密封圈80X3.1	2	GB1235-76
13	Z2113-03530	Bushing	钢背轴承3530	2	
14	D30A8-50201	Body,piston	活塞体	2	
15	HRD05A8503 D05A8-50301	Tube,cylinder R.H.	缸体(右)	1	
-	HRD05A8503 D05A8-50401	Tube,cylinder L.H.	缸体(左)	1	
16	REF340214 23458-42241	U-ring	U型密封圈	4	
17	D30A8-52091	Wearing	支承环	2	
18	REF340270 63626-23071	Bushing	轴套	2	
19	Q700B01	Fitting grease	直通式滑脂嘴	2	ZBT33001.1-88
20	B6050-00047	Ring,snap	挡圈47	2	GB893.1-86
21	D20B8-50211	Bushing	关节轴承	2	
22	B0222-14055	Bolt	螺栓M14X55	2	GB5782-86
23	B4118-00014	Nut	螺母M14	2	GB6170-86
24	B5050-00014	Washer,lock	垫圈14	2	GB93-87
25	HRH22A8309 H22A8-00201	Pin	倾斜缸销轴	2	
26	B0530-10020	Bolt	螺栓M10X1.25X20	2	GB5786-86



图 139/FIG139

护顶架/OVERHEAD GUARD

J1

序号 Item No	图号 Part No	零部件名称 Description	件数 Q'ty	备注 Remark
01	H24C5-10202	Overhead guard	框架总成	1 除 Except CPQ(D)20~30-B4
-	H24C5-10811	Overhead guard	框架总成	1 选用 Option
-	H24C5-10911	Overhead guard	框架总成	1 CPQ(D)20~30-B4 其余车型选用
02	A22A5-10412G	Handle,grip	把手总成	1
03	B8032-06020	Screw	螺钉M6X20	2 GB70-85
04	A22A5-10401	Guard,lamp F	前灯架总成	2
05	B0330-08016	Bolt	螺栓M8X16	6 GB5783-86
06	B5050-00008	Washer,lock	垫圈8	6 GB93-87
07	A22A0-02011	Guard	倒车镜支架	2
08	HRH24C5114 H24C5-12953	Cup	边管罩(左)	1
09	H24C5-10503	Rear pipe L.H.	后支撑杆总成(左)	1 除 Except CPQ(D)20~30-B4
-	H24C5-10861	Rear pipe L.H.	后支撑杆总成(左)	1 选用 Option
-	H24C5-10951	Rear pipe L.H.	后支撑杆总成(左)	1 CPQ(D)20~30-B4 其余车型选用
10	B4216-00012	Nut	螺母M12X1.25	8 GB6171-86
11	H24C5-10404	Rear pipe R.H.	后支撑杆总成(右)	1 除 Except CPQ(D)20~30-B4
-	H24C5-10851	Rear pipe R.H.	后支撑杆总成(右)	1 选用 Option
-	H24C5-10941	Rear pipe R.H.	后支撑杆总成(右)	1 CPQ(D)20~30-B4 其余车型选用
12	B4116-00008	Bolt	螺母M8	2 GB6170-86
13	B5310-00012	Washer	垫圈12	8 GB97.1-86
14	B0530-12035	Bolt	螺栓M12X1.25X35	4 GB5786-86
15	B5050-00012	Washer,lock	垫圈12	12 GB93-87
16	H24C5-12922	Bolt	螺栓	4
17	27354-12341	Washer	垫圈1	4
18	A22A5-12181	Cover	进气罩	2
19	B5410-00008	Washer	垫圈8	2 GB97.2-85
20	HRH24C5114 H24C5-12913	Cup	边管罩(右)	1
21	DK649A	Back-mirror Ass'y	倒车镜总成	2
22	B0320-08050	Bolt	螺栓M8X50	2 GB5783-86

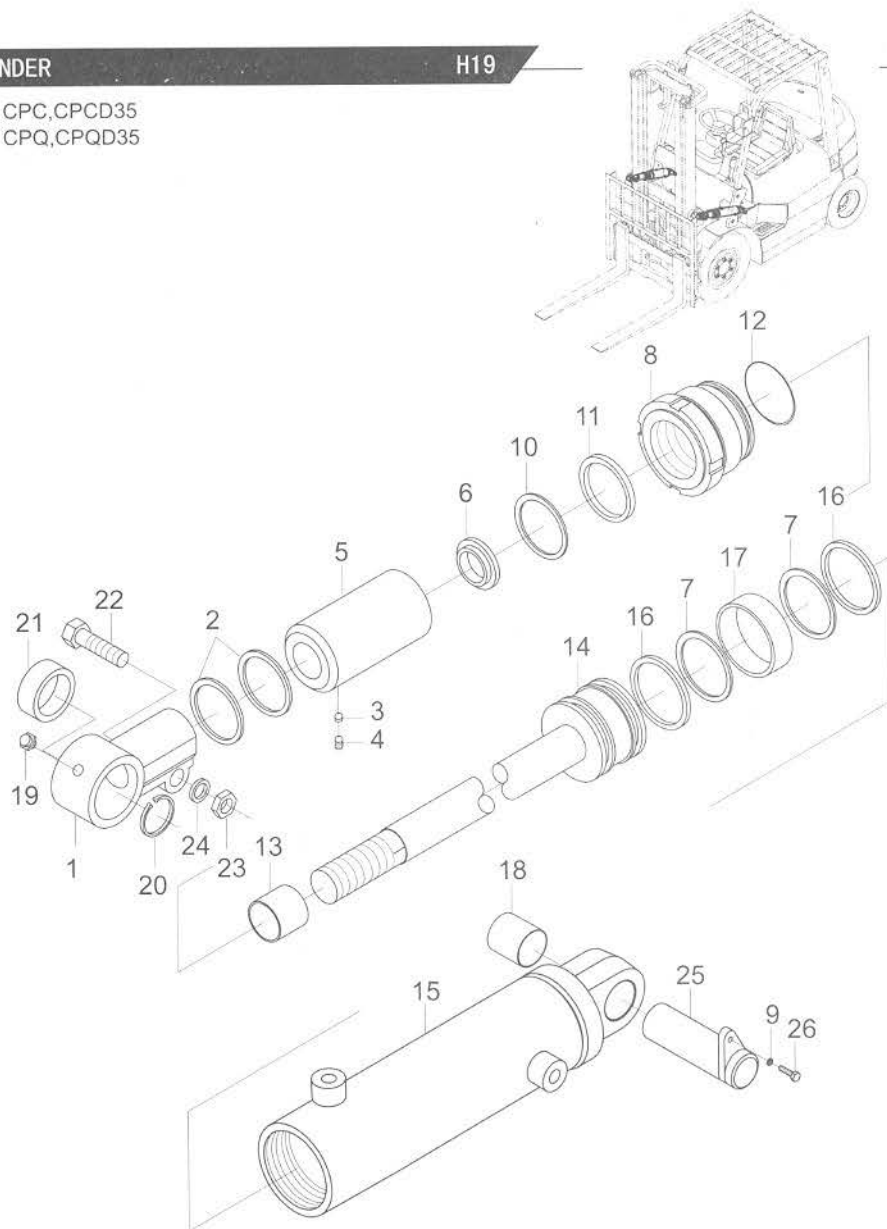
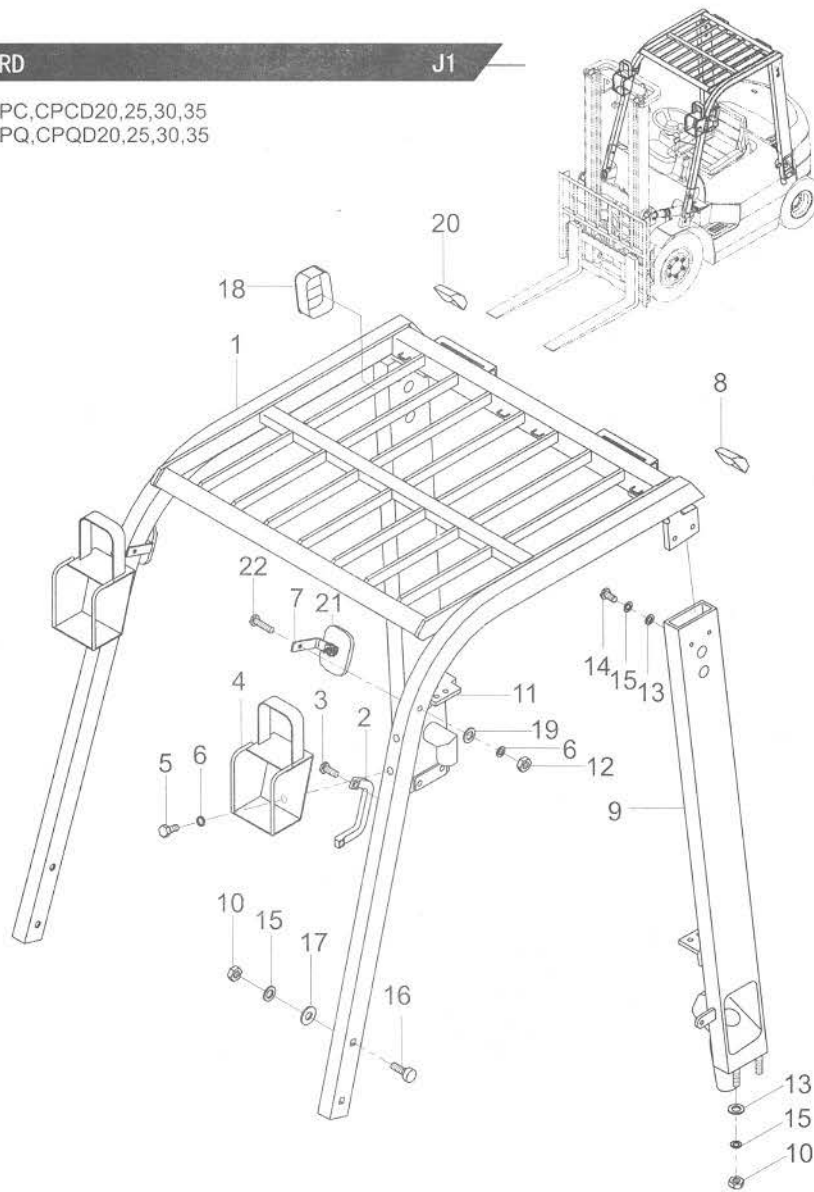
CPC,CPCD20,25,30,35
CPQ,CPQD20,25,30,35

CPC, CPCD20,25,30,35
CPQ, CPQD20,25,30,35

序号 Item No	图号 Part No	零部件名称 Description	件数 Q'ty	备注 Remark
01	6TY40-01-01	Decal,safety 安全标志标牌	2	
02	6TY10-00-19	Name plate 叉式装卸车铭牌	1	
03	6TY40-02-01	Decal,lubrication chart 润滑系统图标牌	1	
04	6TY20-00-151	Decal,capacity chart 负荷曲线图标牌(2t)	1	2t
-	6TY20-00-152	Decal,capacity chart 负荷曲线图标牌(2.5t)	1	2.5t
-	6TY20-00-153	Decal,capacity chart 负荷曲线图标牌(3t)	1	3t
-	6TY20-00-147	Decal,capacity chart 负荷曲线图标牌(3.5t)	1	3.5t
05	6TY40-03-01	Decal 使用须知标牌	1	
06	6TY40-12-01	Decal,caution 启动前检查要领	1	
07	6TY40-00-391	Decal,model H2000系列2t叉车型号标牌	2	2t
-	6TY40-00-392	Decal,model H2000系列2.5t叉车型号标牌	2	2.5t
-	6TY40-00-393	Decal,model H2000系列3t叉车型号标牌	2	3t
-	6TY40-00-402	Decal,model H2000系列3.5t叉车型号标牌	2	3.5t
08	6TY40-13-01	Decal,Praking brake adjust 停车制动调整	1	
09	6TY40-04-01	Decal,fuel 加燃油标牌	1	
10	6TY40-09-01	Decal,antifreeze liquid 加防冻液标牌	1	
11	B2180-03006	Rivet 铆钉3X6	4	GB827-76
12	6TY40-00-398	Decal HELI标牌(1-3t)	2	
13	6TY40-05-01	Decal,adding hydraulic oil 加液压油标牌	1	
14	6TY40-06-03	Decal,capacity 容量标牌	1	
15	6TY40-07-01	Decal,fan safety 风扇安全标牌	1	
16	6TY40-08-01	Decal,tire safety 轮胎安全标牌	1	
17	6TY40-10-01	Decal,sling 起吊标牌	2	
18	6TY40-16-01	Decal,air pressure 轮胎气压	1	
19	6TY40-14-01	Decal,padiok mast space 禁止进入门架后空间	1	
20	6TY40-15-01	Decal,notice thumb hand 注意伤手	1	
21	6TY40-11-01	Decal,HELI forklift truck 合力叉车标牌	2	
22	6TY40-34-01	Decal,strictly prohibit water 严禁冲水标牌		

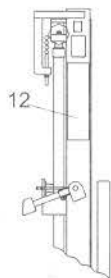
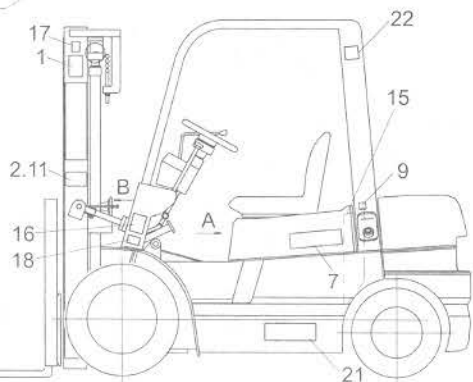
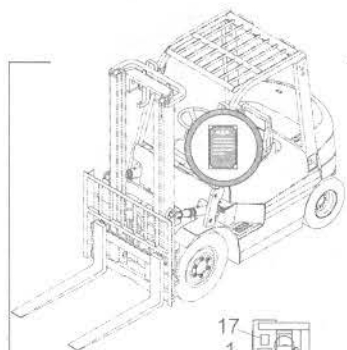

A向



B向

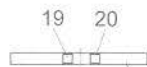

外门架中横梁



图 141/FIG141

标牌(出国)/DECAL (GO ABROAD)

K2

序号 Item No	图号 Part No	零部件名称 Description	件数 Q'ty	备注 Remark
01	6TY40-01-02	Decal,safety 安全标志标牌	2	
02	6TY10-00-19	Name plate 叉式装卸车铭牌	1	中英文对照
-	6TY10-00-21	Name plate 叉式装卸车铭牌	1	中性包装
03	6TY40-02-02	Decal,lubrication chart 润滑系统图标牌	1	
04	6TY20-00-151	Decal,capacity chart 负荷曲线图标牌(2t)	1	2t 中英文对照
-	6TY20-00-152	Decal,capacity chart 负荷曲线图标牌(2.5t)	1	2.5t 中英文对照
-	6TY20-00-153	Decal,capacity chart 负荷曲线图标牌(3t)	1	3t 中英文对照
-	6TY20-00-147	Decal,capacity chart 负荷曲线图标牌(3.5t)	1	中英文对照
-	6TY20-00-155	Decal,capacity chart 负荷曲线图标牌(2t)	1	2t 中性包装
-	6TY20-00-157	Decal,capacity chart 负荷曲线图标牌(2.5t)	1	2.5t 中性包装
-	6TY20-00-158	Decal,capacity chart 负荷曲线图标牌(3t)	1	3t 中性包装
-	6TY20-00-201	Decal,capacity chart 负荷曲线图标牌(3.5t)	1	3.5t 中性包装
05	6TY40-03-02	Decal 使用须知标牌	1	
06	6TY40-12-02	Decal,caution 启动前检查要领	1	
07	6TY40-00-391	Decal,model H2000系列2t叉车型号标牌	2	2t
-	6TY40-00-392	Decal,model H2000系列2.5t叉车型号标牌	2	2.5t
-	6TY40-00-393	Decal,model H2000系列3t叉车型号标牌	2	3t
-	6TY40-00-402	Decal,model H2000系列3.5t叉车型号标牌	2	3.5t
08	6TY40-13-02	Decal,Praking brake adjust 停车制动调整		
09	6TY40-04-02	Decal,fuel 加燃油标牌		
10	6TY40-09-02	Decal,antifreeze liquid 加防冻液液牌		
11	B2180-03006	Rivet 铆钉3X6	4	GB827-76
12	6TY40-00-398	Decal HELI 1 标牌	2	
13	6TY40-05-02	Decal,adding hydraulic oil 加液压油液牌	1	
14	6TY40-06-04	Decal,capacity 容量液牌	1	
15	6TY40-07-02	Decal,fan safety 风扇安全液牌	1	
16	6TY40-08-02	Decal,tire safety 轮胎安全液牌	1	
17	6TY40-10-02	Decal,sling 起吊液牌	2	
18	6TY40-16-17	Decal,air pressure 轮胎气压	1	
19	6TY40-14-02	Decal,padlok mast space 禁止进入门架后空间	1	
20	6TY40-15-02	Decal,notice thumb hand 注意伤手	1	
21	6TY40-34-02	Decal,strictly prohibit water 严禁冲水液牌	1	

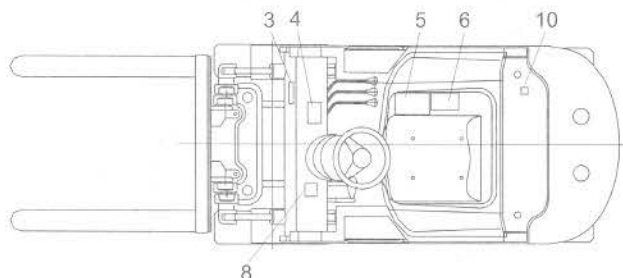
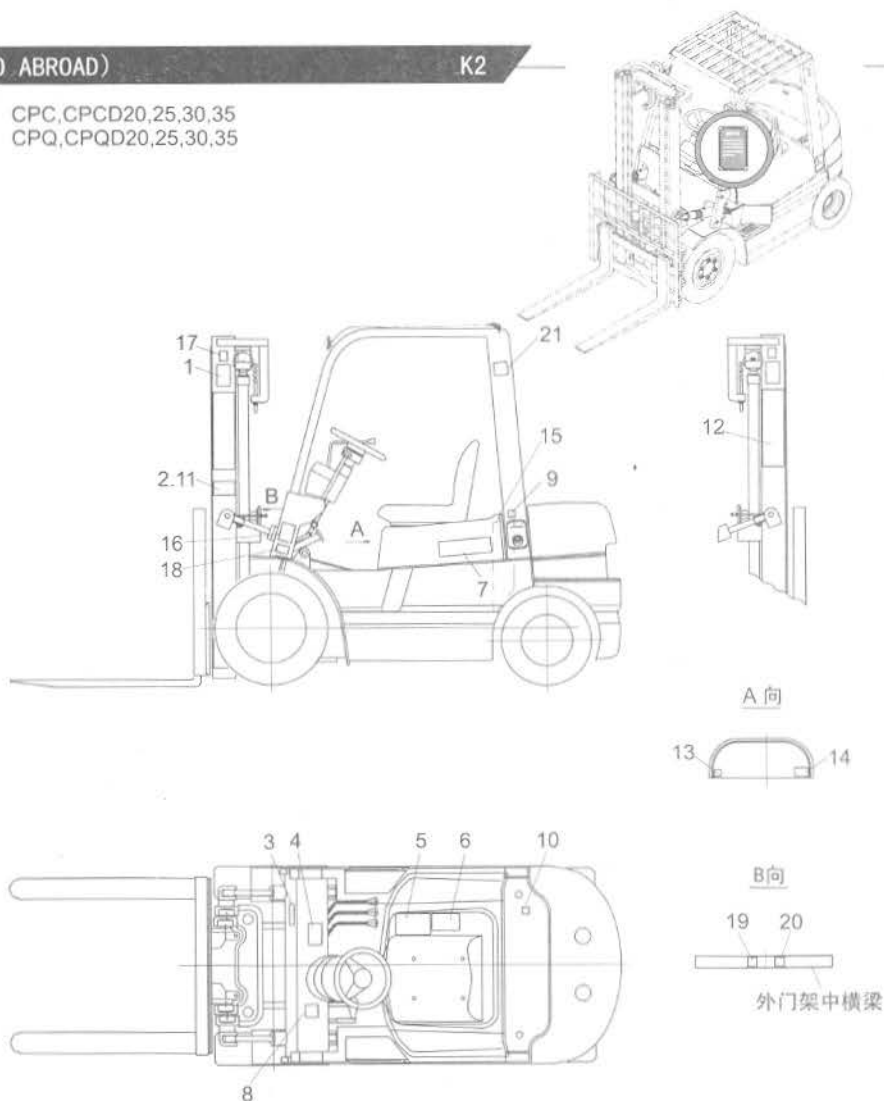



HELI

安徽合力股份有限公司
ANHUI HELI CO., LTD.

地址：安徽 合肥 望江西路15号
电话：0551 3648005
传真：0551 3633431

<http://www.heliforklift.com>
E-mail: heli@helichina.com
邮编：230022

L16-9:2006