



GOODSENSE

零件目录

PARTS MANUAL

5-8t内燃平衡重式叉车

5-8t Internal Combustion Balanced Forklift Truck

说 明

- 一、本零件目录适用于浙江吉鑫祥叉车制造有限公司的FD50G、FD60、FD70G、FD80G型叉车，以使用户在修理及更换零部件时，从中查出所需要的零部件号、零部件名称及数量，并作订货参考。
- 二、在订货时，必须说明叉车的型号及出厂编号，并根据零部件目录说明零部件的完整代号、详细名称及数量。
- 三、本目录中叉车型号的表示方法：

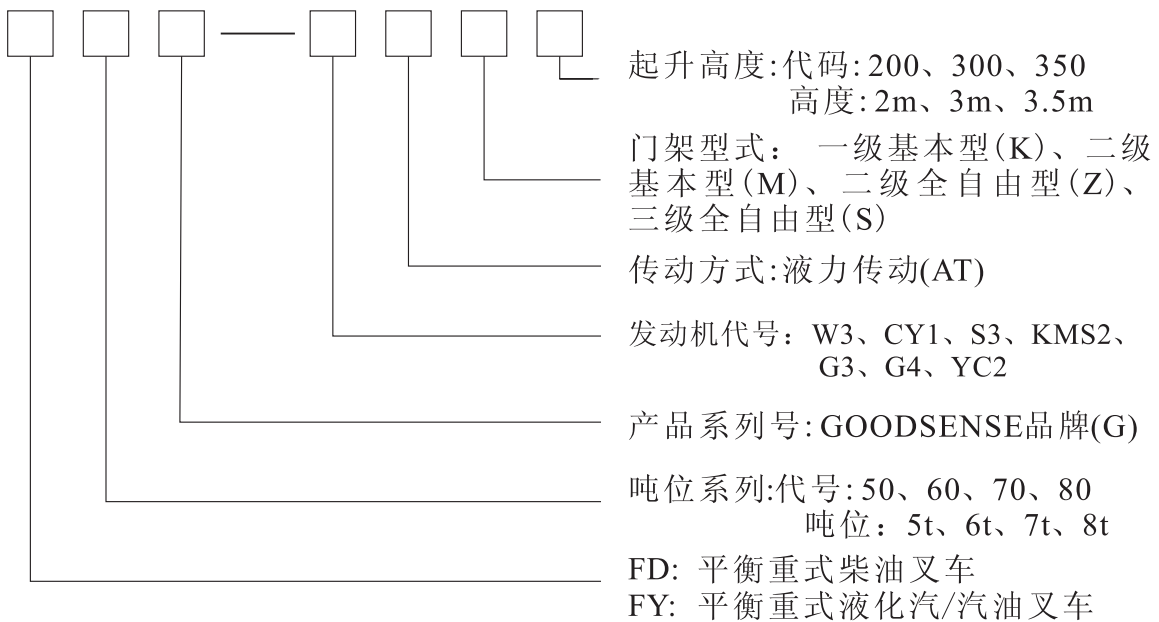

- 四、产品设计更改，恕不另行通知。
- 五、适用型号：用发动机代号和吨位标识区别。
- 六、具体车型与发动机的对应关系。
FD50,60,70,80-W3 配五十铃6BG1QC-02发动机 FD50,60,70,80-KMS2配康明斯QSB4.5-C110 发动机
FD50,60,70,80-CY1 配朝柴CY6102BG-E2-46发动机 FY50,60,70,80-G3配通用非认证型GM4.3发动机
FD50,60,70,80-S3 配三菱S6S-T发动机 FY50,60,70,80-G4配通用认证型GM4.3发动机
FD50,60,70,80-YC2 配玉柴YC6B125-T20(简称玉柴6108)发动机

注：EX-A表示向美国和加拿大出口而制造的专用零件
EX-B表示面向一般市场而制造的专用零件

FOREWORD

1. This parts list is applied to the “ZHEJIANG GOODSENSE FORKLIFT COMPANY LTD” FD50G、FD60、FD70G、FD80G forklift truck . It is intended for users to identify the name , number and quantity of the parts replaced or repaired and to order them from the suppliers works .

2. When order parts , it is necessary to state the model of the forklift truck , its date of manufacture and according to this Part List , to state the whole number , the whole name and quantity .

3. Among the models of the forklifts truck :

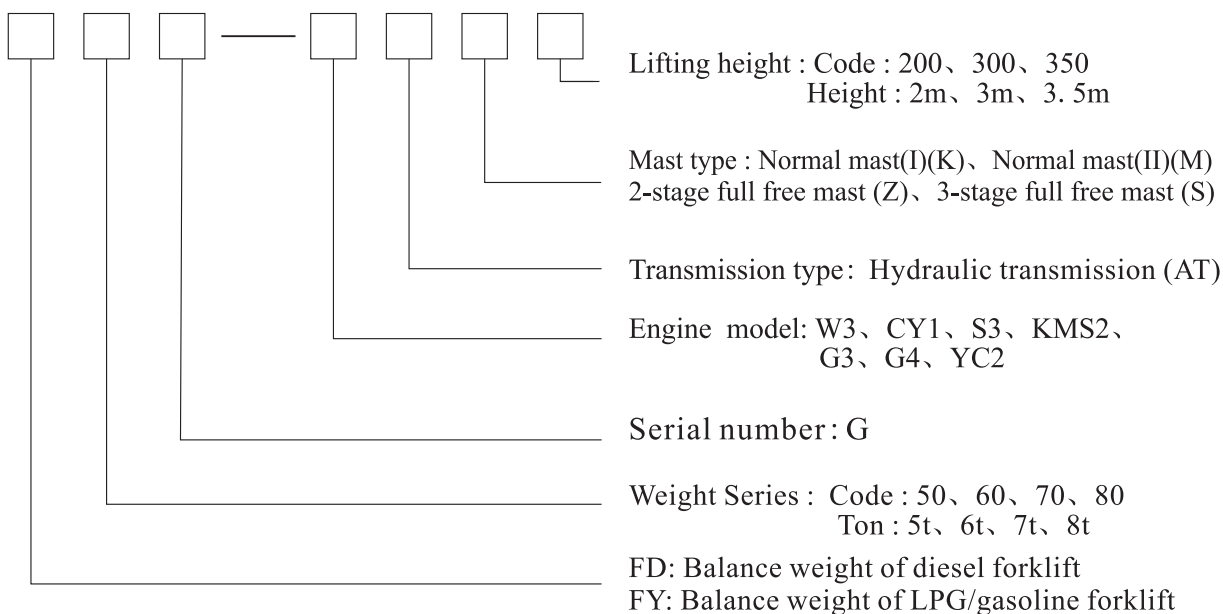

4. If there is any change, we will not notify.

5. Model application: Engine model and maximum capacity.

6. The following trucks are provided with corresponding engine.

FD50,60,70,80-W3/6BG1QC-02 engine FD50,60,70,80-KMS2/QSB4.5-C110 engine

FD50,60,70,80-CY1/CY6102BG-E2-46 engine FY50,60,70,80-G3/GM4.3 engine

FD50,60,70,80-S3/S6S-T engine FY50,60,70,80-G4/GM4.3 engine

FD50,60,70,80-YC2/YC6B125-T20(简称玉柴6108) engine

Note: EX-A: Special parts made for the forklift trucks exported to US and Canada .

EX-B: Parts made for common forklift trucks markets .

分类索引

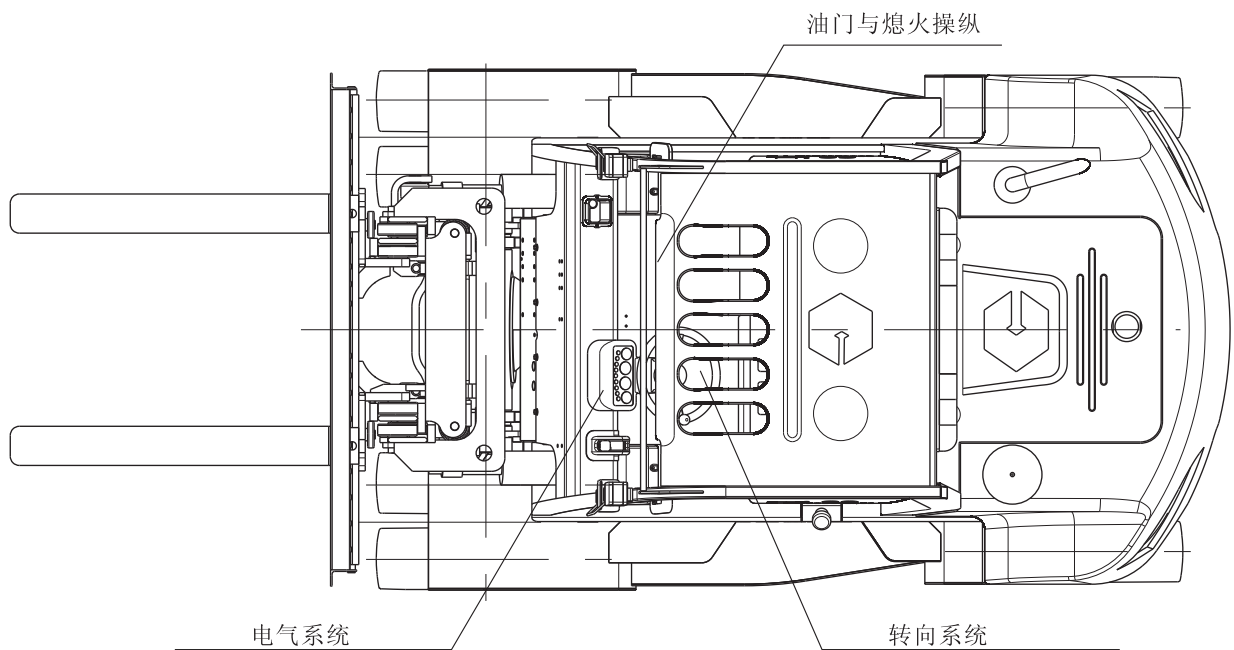
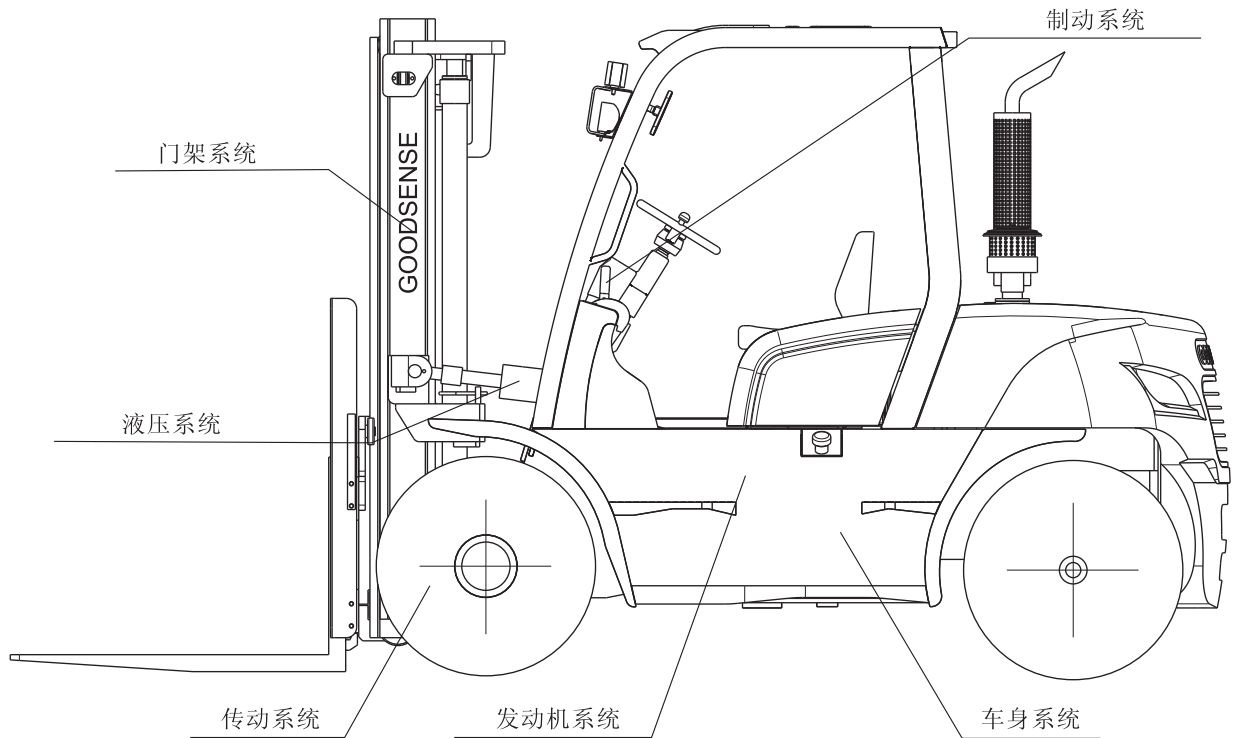

GROUP INDEX

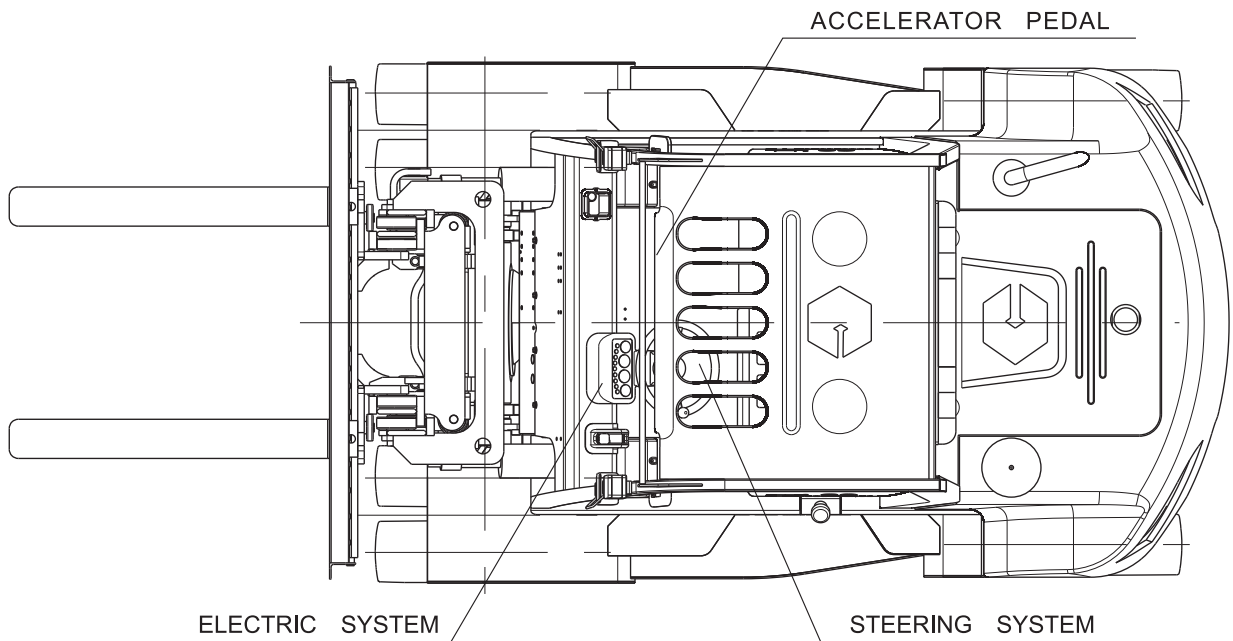
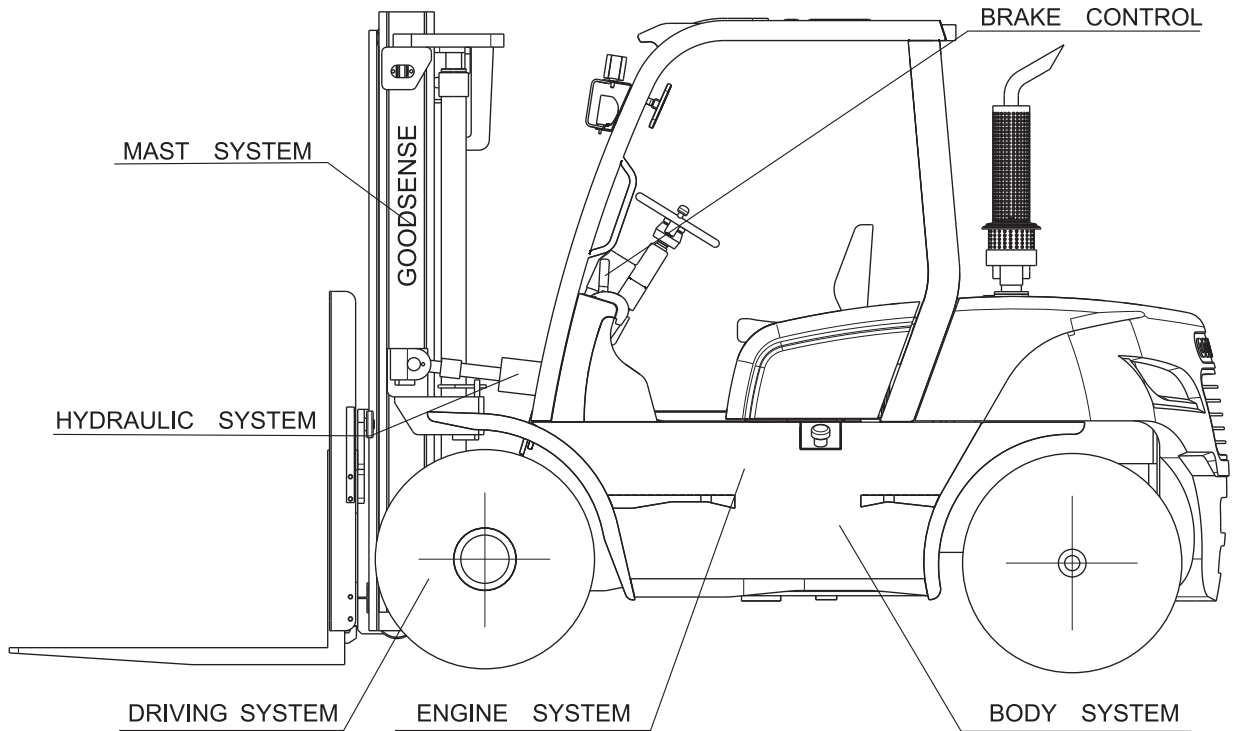

目 录

INDEX

一、发动机系统 Engine system

发动机安装 Engine mount	1-01
进气系统 Air intake system	1-09
冷却系统 Coolling system	1-17
燃油系统 Fuel system	1-23
排气系统 Exhaust system	1-27
变矩器冷却系统 Tor-con oil cooling system	1-39

二、传动系统 Driving system

减速器和差速器 Reduction&Differential	2-01
传动装置安装 Drive unit mount	2-05
传动装置 Drive unit	2-09
变矩器(1/2) Torque-converter (1/2)	2-11
变矩器(2/2) Torque-converter (2/2)	2-13
变速箱(1/2) Transmission (1/2)	2-15
变速箱(2/2) Transmission (2/2)	2-19
控制阀总成 Control valve ass'y	2-21
供油泵 Charging pump	2-25
离合器 I Hydraulic clutch I	2-27
离合器 II Hydraulic clutch II	2-29
停车制动器总成 Parking brake ass'y	2-31
驱动桥 Drive axle	2-33
驱动轮总成 Drive wheel assembly	2-37
轮式制动器 Wheel brake	2-39
变速箱变速操纵 Transmission control linkage	2-43

三、转向系统 Steering system

转向操纵 Steering control	3-01
转向桥 Steering axle	3-05
转向轮 Steering wheel	3-09
转向油缸 Steering cylinder	3-11

四、油门操纵 Accelerator pedal

油门操纵	Accelerator pedal	· · · · ·	4-01
五、制动系统	Brake system		
行车制动与微动操纵	Brake & inching control	· · · · ·	5-01
行车制动管路系统	Brake Piping System	· · · · ·	5-09
停车制动	Brake lever	· · · · ·	5-21
六、车身系统	Body system		
车架与平衡重	Frame & balance	· · · · ·	6-01
机罩底板类及座椅	Hood、Floor Board & Seat	· · · · ·	6-13
护顶架	Head guard	· · · · ·	6-19
七、液压系统	Hydraulic system		
液压油箱	Oil tank	· · · · ·	7-01
阀操纵总成(二片)	Valve control linkage (two-throw)	· · · · ·	7-03
阀操纵总成(三片)	Valve control linkage (three-throw)	· · · · ·	7-05
阀操纵总成(四片)	Valve control linkage (four-throw)	· · · · ·	7-07
阀操纵总成(五片)	Valve control linkage (five-throw)	· · · · ·	7-09
液压管路	Hydraulic pipeline	· · · · ·	7-11
八、起重系统	Lifting system		
门架管路系统(基本型)	Hydraulic system mast(Normal mast KM)	· · · · ·	8-01
门架管路系统(二节全自由)	Hydraulic system mast(Full Free 2-Stage Mast KZM)		8-03
门架管路系统(三节全自由)	Hydraulic system mast(Full Free 3-Stage Mast KZM)		8-06
货叉	Fork	· · · · ·	8-11
货叉架(基本型)	Lift Bracket Normal Mast	· · · · ·	8-13
货叉架(二节全自由)	Lift Bracket Full Free 2-Stage Mast	· · · · ·	8-15
货叉架(三节全自由)	Lift Bracket Full Free 3-Stage Mast	· · · · ·	8-17
门架(基本型)	Mast (Normal mast KM)	· · · · ·	8-19
门架(二节全自由)	Mast (Full free 2-stage mast KZM)	· · · · ·	8-21
门架(三节全自由)	Mast (Full free 3-stage mast KZM)	· · · · ·	8-23
起升油缸(基本型)	Lift Cylinder(Normal Mast KM)	· · · · ·	8-25
前起升油缸(二节全自由)	Front Lift Cylinder (Full Free 2-Stage Mast KZM)	· · ·	8-29
前起升油缸(三节全自由)	Front Lift Cylinder (Full Free 3-Stage Mast KZM)	· · ·	8-31
后起升油缸(二节全自由)	Rear Lift Cylinder (Full Free 2-Stage Mast KZM)	· · ·	8-33

后起升油缸(三节全自由) Rear Lift Cylinder (Full Free 3-Stage Mast KZM) . . .	8-37
倾斜油缸 Tilt cylinder	8-41
九、电气系统 Electric system	
电气系统 Electric system	9-01
十、标牌 Scutcheon	
标牌 Scutcheon	10-01

一、发动机系统

ENGINE SYSTEM

发动机安装
Engine mount

FD50,60,70,80-CY1/W3

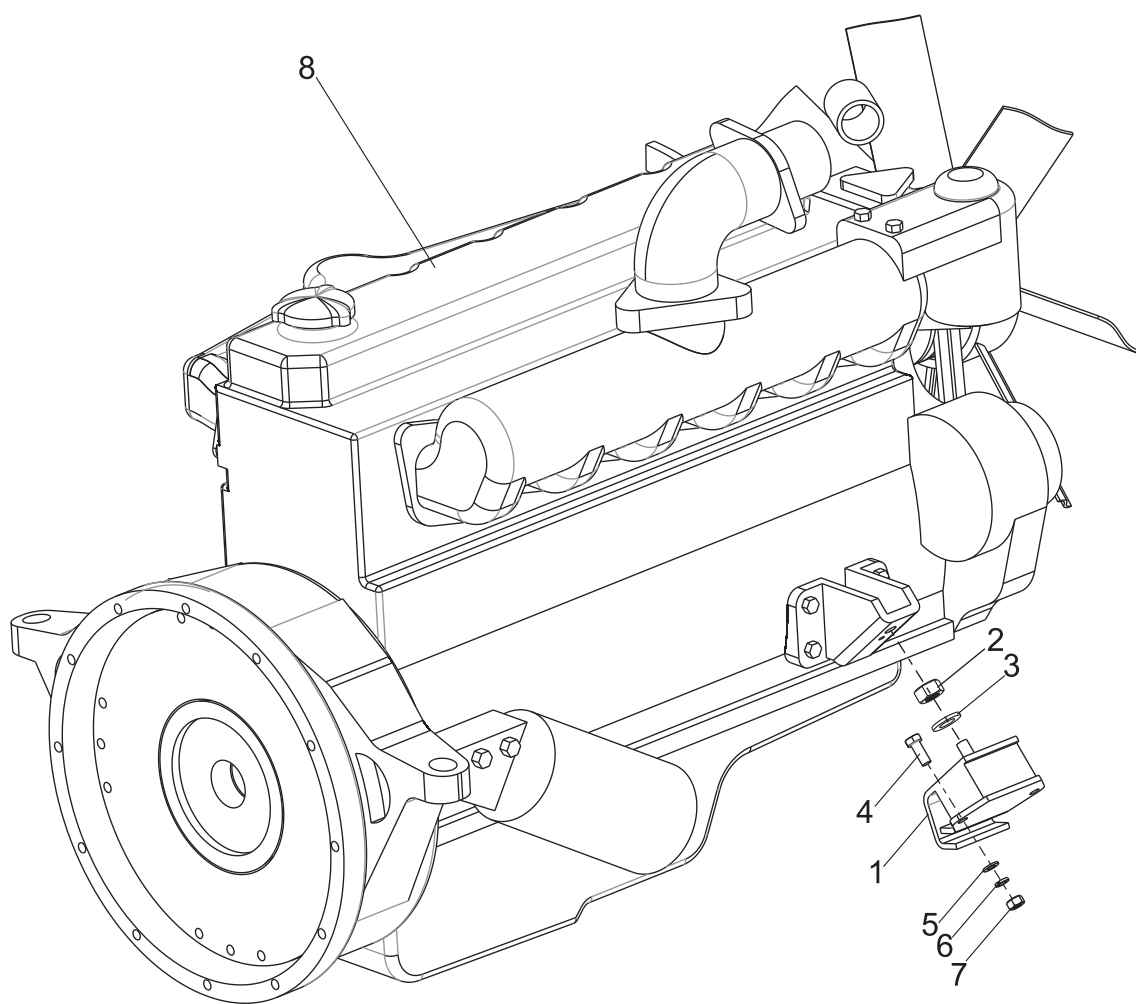

发动机安装
Engine mount

FD50,60,70,80-CY1/W3

序号 Item	零件号 Part No	零部件名称 Description	数量 Q'ty	备注 Remark
1	A50A5-10100	机脚垫 Rubber	2	FD50,60,70,80-CY1
-	A50B5-10300	机脚垫 Rubber	2	FD50,60,70,80-W3
2	GB/T6171	螺母 M12×1.25 Nut	2	
3	GB/T93	弹垫12 Washer,Lock	2	
4	GB/T5783	螺栓 M10×35 Bolt	4	
5	GB/T97.1	平垫10 Washer	4	
6	GB/T93	弹垫10 Washer,Lock	4	
7	GB/T6170	螺母 M10 Nut	4	
8	A50A5-10300	6102发动机 Engine	1	FD50,60,70,80-CY1
-	A50B5-10200	6BG1发动机 Engine	1	FD50,60,70,80-W3

发动机安装
Engine mount

FD50,60,70,80-S3/YC2

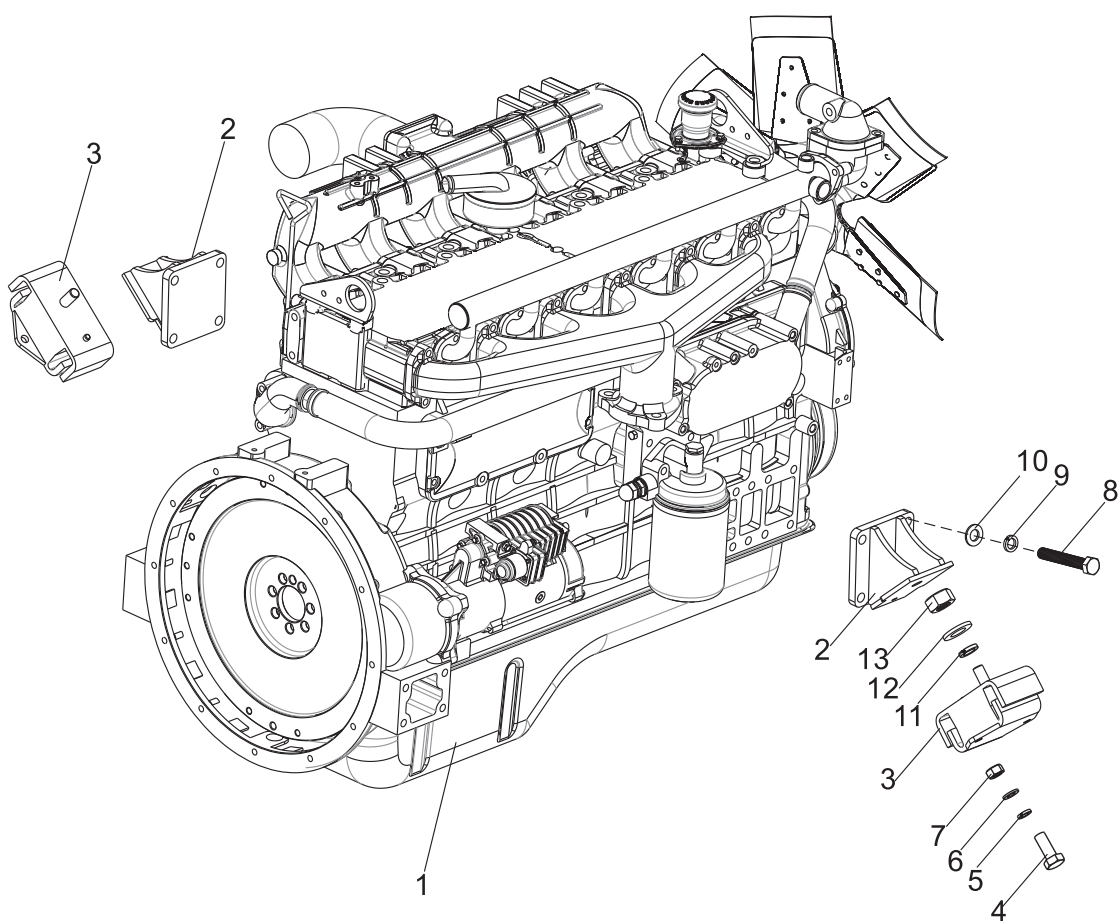

发动机安装
Engine mount

FD50,60,70,80-S3/YC2

序号 Item	零件号 Part No	零部件名称 Description	数量 Q'ty	备注 Remark
1	A50E5-10100	三菱S6S-T发动机 Engine	1	FD50,60,70,80-S3
-	A50G5-10100	玉柴6108发动机 Engine	1	FD50,60,70,80-YC2
2	A50E5-10300	发动机机脚 Engine support	2	FD50,60,70,80-S3
-	A50G5-10300	发动机机脚 Engine support	2	FD50,60,70,80-YC2
3	A50E5-10200	机脚垫 Rubber	2	FD50,60,70,80-S3
-	A50G5-10200	机脚垫 Rubber	2	FD50,60,70,80-YC2
4	GB/T5783	螺栓 M10×30 Bolt	4	
5	GB/T93	弹垫10 Washer,Lock	4	
6	GB/T97.1	平垫10 Washer	4	
7	GB/T6170	螺母 M10 Nut	4	
8	GB/T5783	螺栓 M12×30 Bolt	8	
9	GB/T93	弹垫12 Washer,Lock	8	
10	GB/T97.1	平垫12 Washer	8	
11	GB/T93	弹垫14 Washer,Lock	2	
12	GB/T97.1	平垫14 Washer	2	
13	GB/T6171	螺母 M14×1.5 Nut	2	

发动机安装
Engine mount

FD50,60,70,80-KMS2

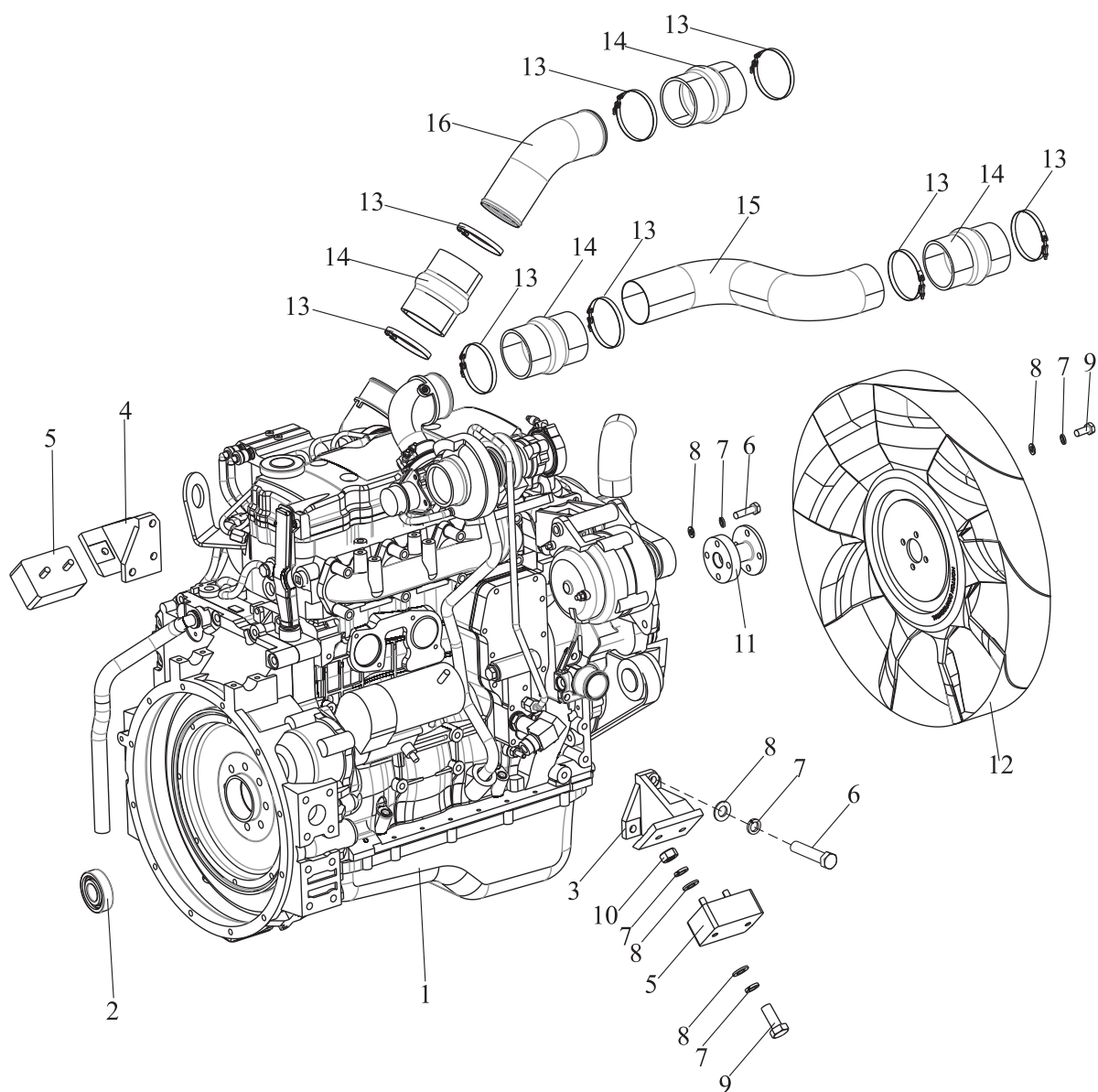

发动机安装
Engine mount

FD50,60,70,80-KMS2

序号 Item	零件号 Part No	零部件名称 Description	数量 Q'ty	备注 Remark
1	A90F5-10100	康明斯QSB4.5-C110 发动机 Engine	1	
2	A90F5-10001	轴承6306 Bearing	1	
3	A90F5-10004	发动机左机脚 Engine support	1	
4	A90F5-10005	发动机右机脚 Engine support	1	
5	A120A5-10003	发动机减震垫 Rubber	2	
6	GB/T5783	螺栓 M10×35 Bolt	10	
7	GB/T93	弹垫10 Washer,Lock	18	
8	GB/T97.1	平垫10 Washer	18	
9	GB/T5783	螺栓 M10×25 Bolt	8	
10	GB/T6170	螺母 M10 Nut	4	
11	A90F5-10003	风扇垫块 Fan base	1	
12	A90F5-10002	风扇 Fan	1	
13	TK000-080100	T型喉箍 ϕ 80-100 Clip	8	
14	A90F5-11007	中冷器接管 Intercooler pipe	4	
15	A90F5-11008	中冷器进气管 Intercooler intake	1	
16	A90F5-11009	中冷器出气管 Intercooler freeing pipe	1	

发动机安装
Engine mount

FY50,60,70,80-G3/G4

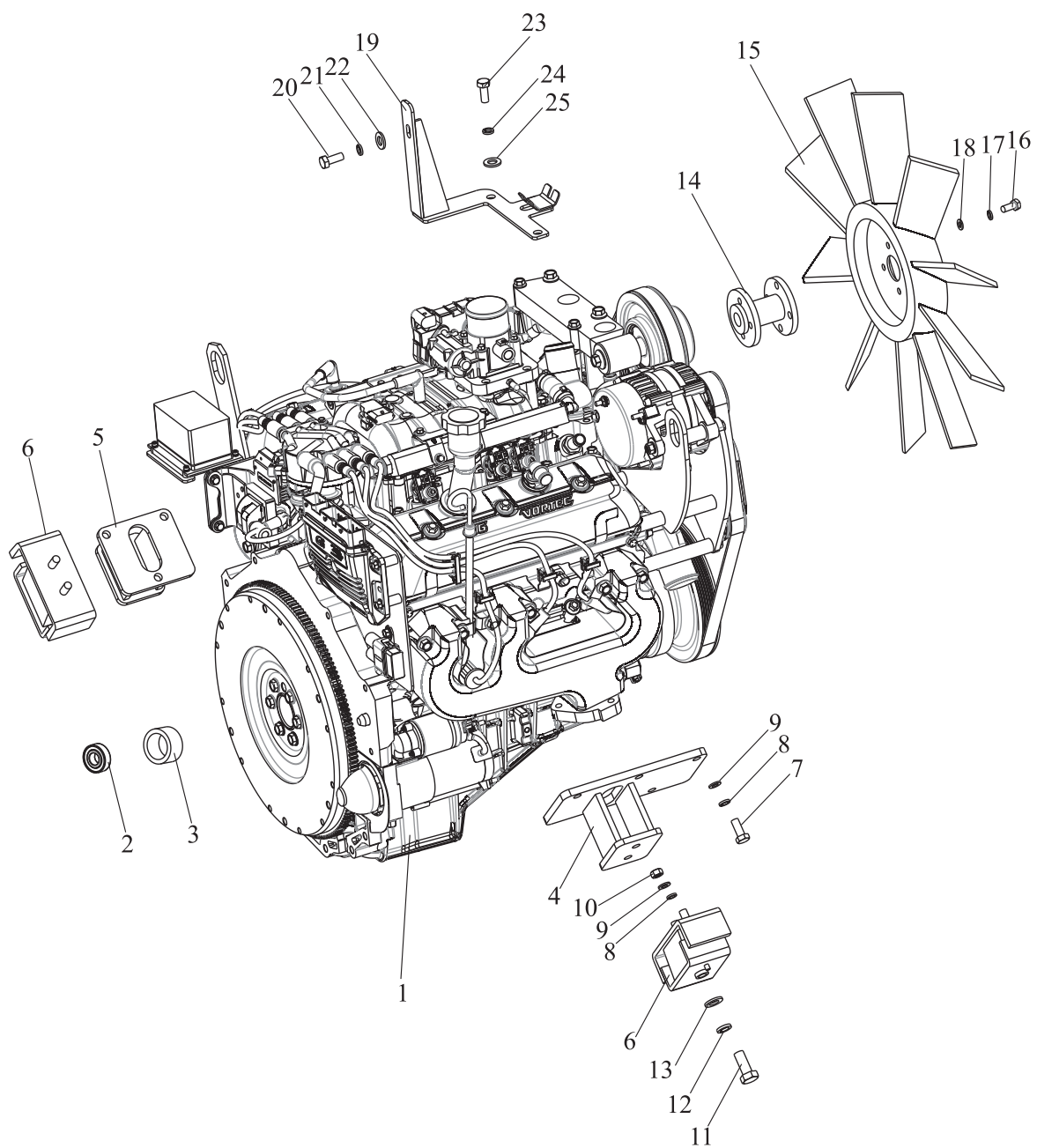

发动机安装
Engine mount

FY50,60,70,80-G3/G4

序号 Item	零件号 Part No	零部件名称 Description	数量 Q'ty	备注 Remark
1	A50I5-10200	GM4.3认证型发动机 Engine	1	FY50,60,70,80-G4
-	A45F5-10200	GM4.3非认证型发动机 Engine	1	FY50,60,70,80-G3
2	A30BD5-10003	轴承 Bearing	1	
3	A30BD5-10005	衬套 Bushing	1	
4	A50I5-10300	发动机左机脚 Engine support	1	FY50,60,70,80-G4
-	A50F5-10200	发动机机脚 Engine support	2	FY50,60,70,80-G3
5	A50I5-10200	发动机右机脚 Engine support	1	FY50,60,70,80-G4
6	A50F5-10300	机脚垫 Rubber	2	
7	GB/T5783	螺栓 M10×35 Bolt	6	
8	GB/T93	弹垫10 Washer,Lock	10	
9	GB/T97.1	平垫10 Washer	10	
10	GB/T6170	螺母 M10 Nut	4	
11	GB/T5783	螺栓 M12×30 Bolt	2	
12	GB/T93	弹垫12 Washer,Lock	2	
13	GB/T97.1	平垫12 Washer	2	
14	A50F5-10002	风扇座 Fan base	1	
15	A50F5-10004	风扇 Fan	1	
16	GB/T5786	螺栓 M8×1.25×75 Bolt	4	
17	GB/T93	弹垫8 Washer,Lock	4	
18	GB/T97.1	平垫8 Washer	4	
19	A50I5-10500	蒸发器固定板 Evaporator fixing plate	1	FY50,60,70,80-G3
20	GB/T5783	螺栓 M8×10 Bolt	1	FY50,60,70,80-G3
21	GB/T93	弹垫8 Washer,Lock	1	FY50,60,70,80-G3
22	GB/T97.1	平垫8 Washer	1	FY50,60,70,80-G3
23	GB/T5783	螺栓 M10×15 Bolt	2	FY50,60,70,80-G3
24	GB/T93	弹垫10 Washer,Lock	2	FY50,60,70,80-G3
25	GB/T97.1	平垫10 Washer	2	FY50,60,70,80-G3

进气系统
Air intake system

FD50,60,70,80-CY1/W3

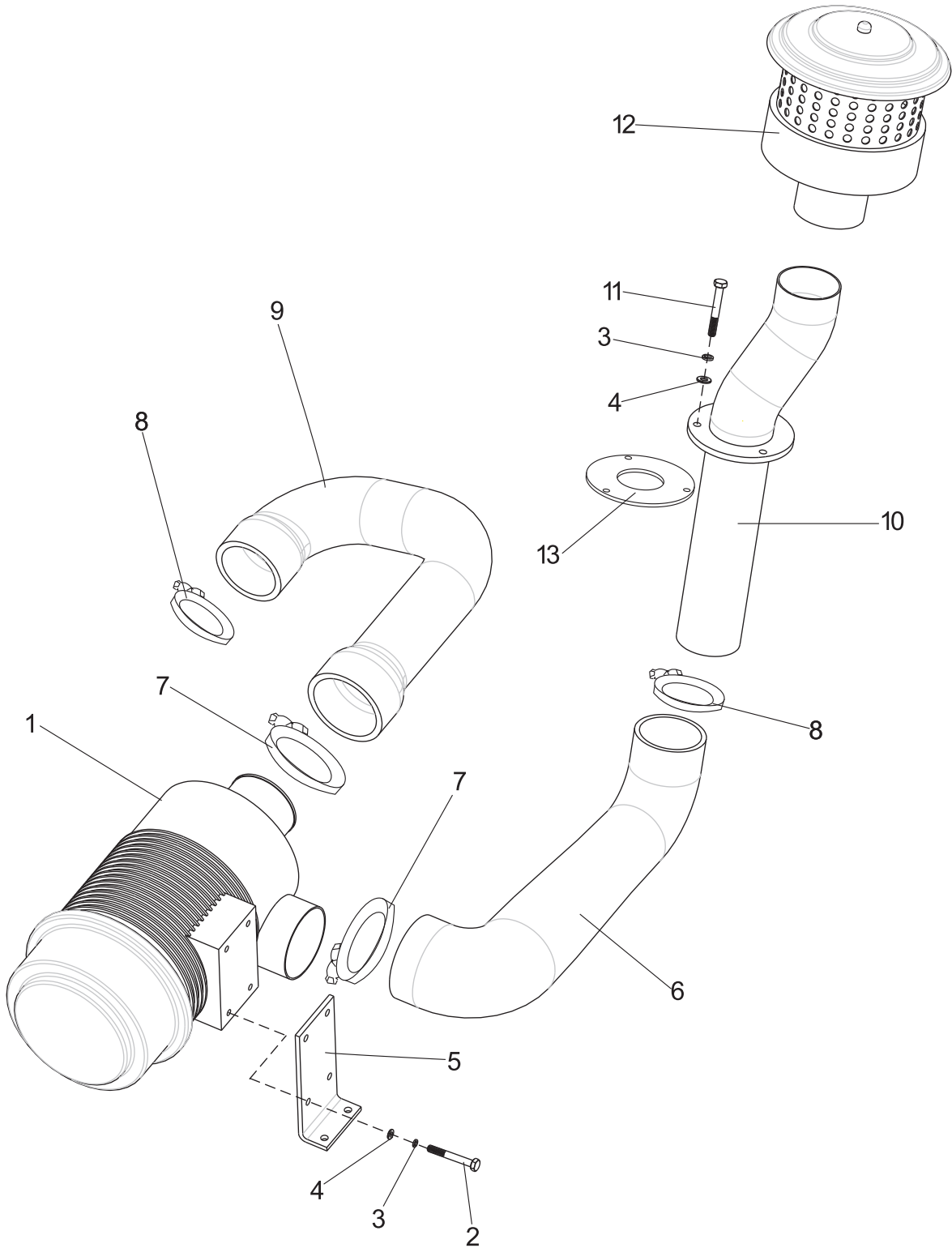

进气系统
Air intake system

FD50,60,70,80-CY1/W3

序号 Item	零件号 Part No	零部件名称 Description	数量 Q'ty	备注 Remark
1	A50A5-10200	空气滤清器 Air cleaner	1	
2	GB/T5783	螺栓 M8×20 Bolt	6	
3	GB/T93	弹垫 8 Washer	9	
4	GB/T97.1	平垫 8 Washer	9	
5	A50C5-10002	空滤器安装板 Air cleaner installation	1	
6	A50C5-10001	进气管A Hose, intake air	1	FD50,60,70,80-CY1/W3
-	A50E5-10004	进气管A Hose, intake air	1	FD50,60,70,80-S3
7	TK000-90110	卡箍 φ90-110 Clip	2	
8	TK000-80100	卡箍 φ80-100 Clip	2	
9	A50A5-10001	进气管B Hose, intake air	1	FD50,60,70,80-CY1/W3
-	A50E5-10003	进气管B Hose, intake air	1	FD50,60,70,80-S3
10	A90D1-10010	空滤器支架 Air filter bracket	2	普通护顶架选用
-	A50C5-10200	进气管总成 Intake pipe ass'y	2	驾驶室护顶架选用
11	GB/T5783	螺栓 M8×25 Bolt	3	
12	A50C5-10100	空气粗滤器 Air thick filters	1	
13	A50C5-10005	橡胶垫 Rubber pad	1	

进气系统
Air intake system

FD50,60,70,80-YC2

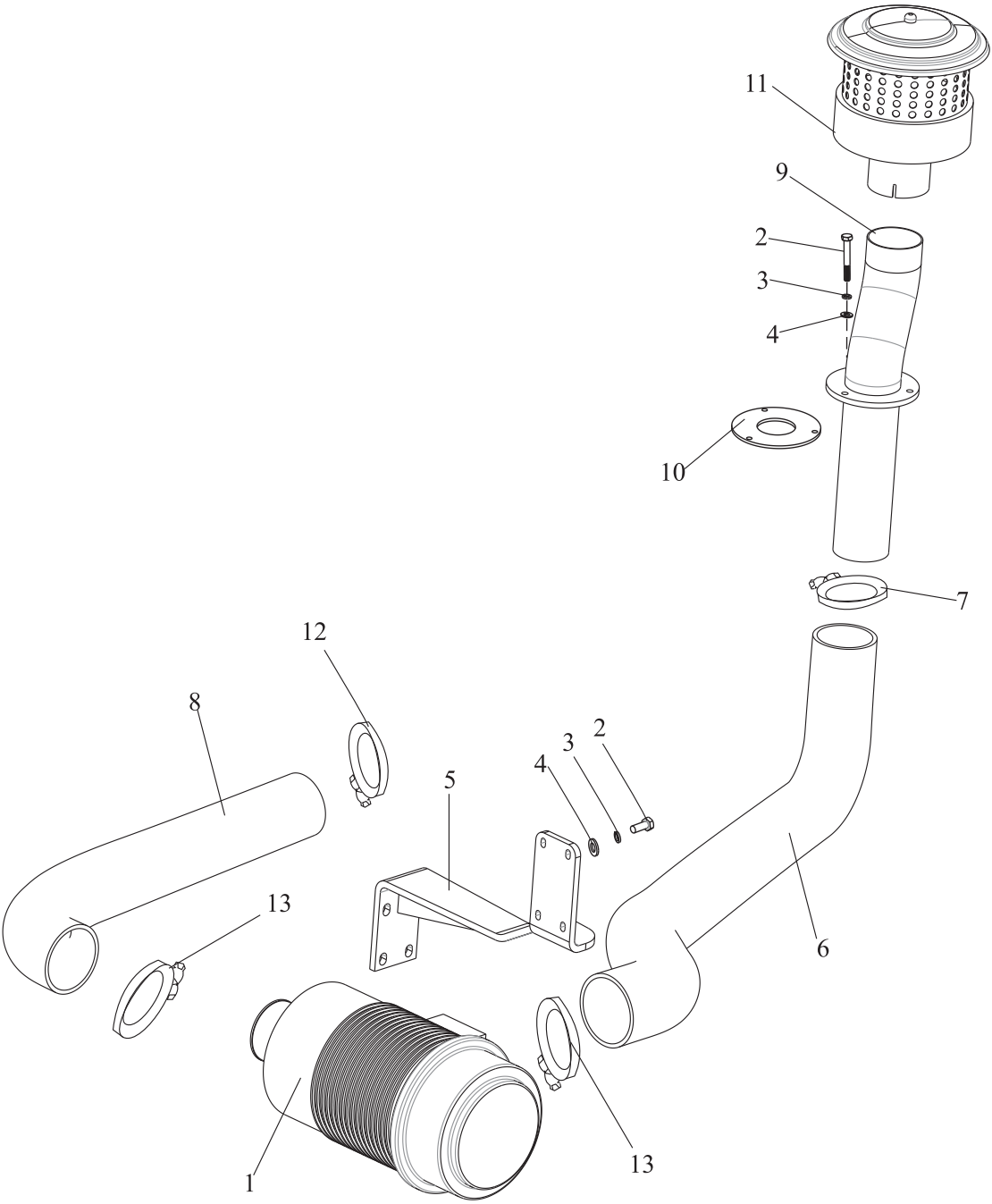

进气系统
Air intake system

FD50,60,70,80-YC2

序号 Item	零件号 Part No	零部件名称 Description	数量 Q'ty	备注 Remark
1	A50A5-10200	空气滤清器 Air cleaner	1	
2	GB/T5783	螺栓 M8×25 Bolt	7	
3	GB/T93	弹垫 8 Washer	7	
4	GB/T97.1	平垫 8 Washer	7	
5	A50G5-10500	空滤器支架 Air cleaner bracket	1	
6	A50G5-10001	进气管A Hose, intake air	1	
7	TK000-80100	卡箍 φ80-100 Clip	1	
8	A50G5-10002	进气管B Hose, intake air	1	
9	A90D1-10010	空滤器支架 Air filter bracket	2	普通护顶架选用
-	A50C5-10200	进气管总成 Intake pipe ass'y	2	驾驶室护顶架选用
10	A50C5-10005	橡胶垫 Rubber pad	1	
11	A50C5-10100	空气粗滤器 Air thick filters	1	
12	TK000-50070	卡箍 φ50-70 Clip	1	
13	TK000-90110	卡箍 φ90-110 Clip	2	

进气系统
Air intake system

FD50,60,70,80-KMS2

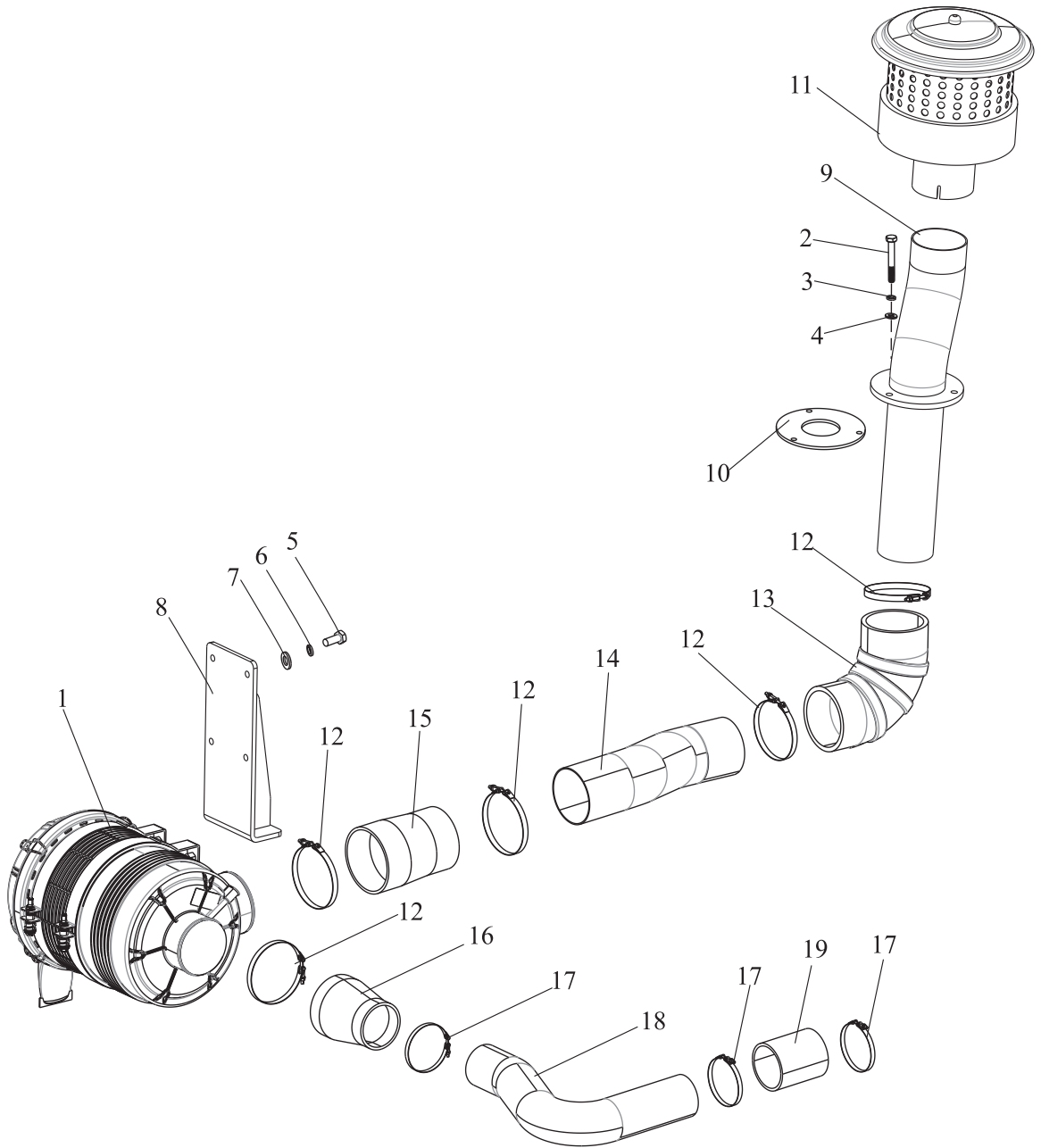

进气系统
Air intake system

FD50,60,70,80-KMS2

序号 Item	零件号 Part No	零部件名称 Description	数量 Q'ty	备注 Remark
1	A90F5-10200	空气滤清器 Air cleaner	1	
2	GB/T5783	螺栓 M8×25 Bolt	3	
3	GB/T93	弹垫 8 Washer	3	
4	GB/T97.1	平垫 8 Washer	3	
5	GB/T5783	螺栓 M10×25 Bolt	4	
6	GB/T93	弹垫 10 Washer	4	
7	GB/T97.1	平垫 10 Washer	4	
8	D90F1-10300	空滤器安装板 Air cleaner installation	1	
9	A120A5-10400	进气管总成 Intake pipe ass'y	1	
10	A50C5-10005	橡胶垫 Rubber pad	1	
11	A120A5-10300	空气预滤器 Air thick filters	1	
12	TK000-110130	T型喉箍 φ 110-130 Clip	5	
13	A90F5-11001	进气弯管 Hose, intake air	1	
14	A50K5-10001	进气管A Hose, intake air	1	
15	A90F5-11003	进气接管A Hose, intake air	1	
16	A90F5-11004	进气接管B Hose, intake air	1	
17	TK000-080100	T型喉箍 φ 80-100 Clip	3	
18	A50K5-11003	进气管B Hose, intake air	1	
19	A90F5-11006	进气接管C Hose, intake air	1	

进气系统
Air intake system

FY50,60,70,80-G3/G4

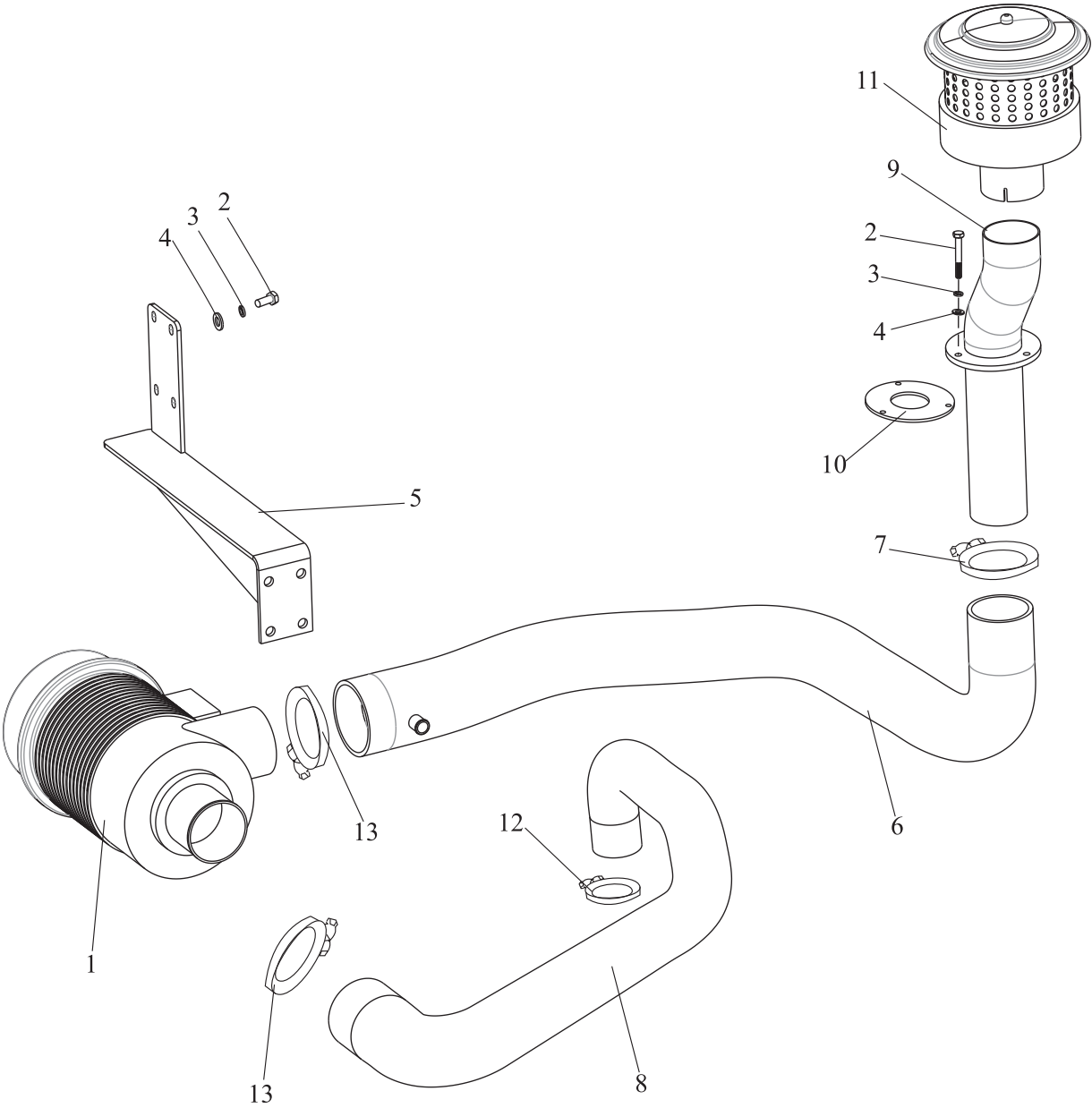

进气系统
Air intake system

FY50,60,70,80-G3/G4

序号 Item	零件号 Part No	零部件名称 Description	数量 Q'ty	备注 Remark
1	A50A5-10200	空气滤清器 Air cleaner	1	
2	GB/T5783	螺栓 M8×25 Bolt	7	
3	GB/T93	弹垫 8 Washer	7	
4	GB/T97.1	平垫 8 Washer	7	
5	A50I5-10400	空滤器安装板 Air cleaner installation	1	FY50,60,70,80-G4
-	A50F5-10400	空滤器安装板 Air cleaner installation	1	FY50,60,70,80-G3
6	A50I5-10001	进气管A Hose, intake air	1	FY50,60,70,80-G4
-	A50F5-10004	进气管A Hose, intake air	1	FY50,60,70,80-G3
7	TK000-80100	卡箍 φ 80-100 Clip	1	
8	A50I5-10002	进气管B Hose, intake air	1	FY50,60,70,80-G4
-	A50F5-10003	进气管B Hose, intake air	1	FY50,60,70,80-G3
9	A90D1-10010	空滤器支架 Air filter bracket	1	普通护顶架选用
-	A50C5-10200	进气管总成 Intake pipe ass'y	1	驾驶室护顶架选用
10	A50C5-10005	橡胶垫 Rubber pad	1	
11	A50C5-10100	空气粗滤器 Air thick filters	1	
12	TK000-50070	卡箍 φ 50-70 Clip	1	
13	TK000-90110	卡箍 φ 90-110 Clip	2	

冷却系统
Cooling system

FD50,60,70,80-CY1/W3/S3
FY50,60,70,80-G3/G4

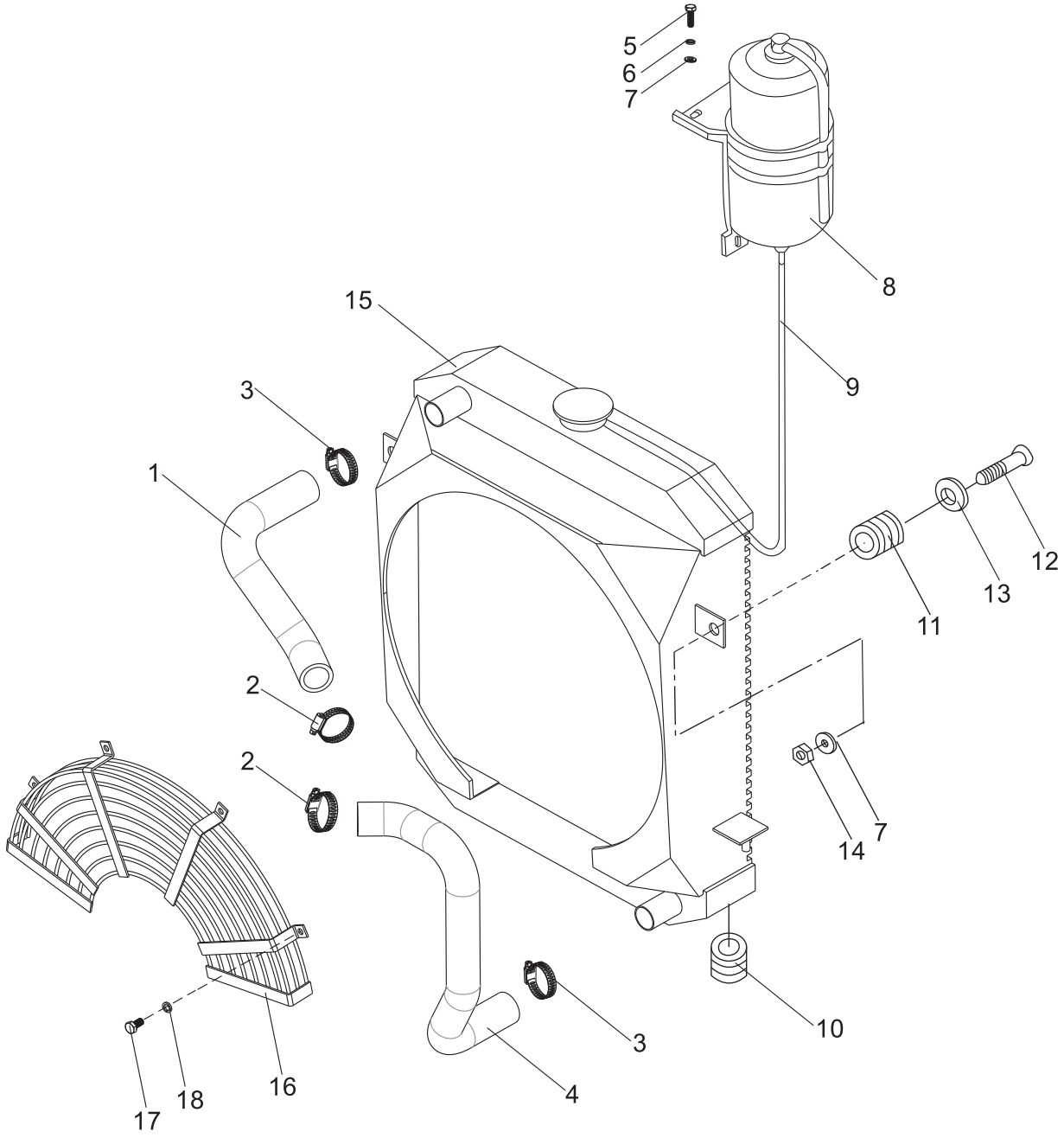

冷却系统
Cooling system

FD50,60,70,80-CY1/W3/S3
FY50,60,70,80-G3/G4

序号 Item	零件号 Part No	零部件名称 Description	数量 Q'ty	备注 Remark
1	A50A5-40001	上水管 Hose	1	FD50,60,70,80-CY1/W3
-	A50E5-40001	上水管 Hose	1	FD50,60,70,80-S3
-	A50F5-40001	上水管 Hose	1	FY50,60,70,80-G3
-	A50I5-40001	上水管 Hose	1	FY50,60,70,80-G4
2	TK000-44064	卡箍 $\phi 44\sim 64$ Clip	2	FD50,60,70,80-CY1/W3
-	TK000-44064	卡箍 $\phi 44\sim 64$ Clip	0	FD50,60,70,80-S3 FY50,60,70,80-G3/G4
3	TK000-38057	卡箍 $\phi 38\sim 57$ Clip	2	FD50,60,70,80-CY1/W3
-	TK000-38057	卡箍 $\phi 38\sim 57$ Clip	4	FD50,60,70,80-S3
4	A50A5-40002	下水管 Hose	1	FD50,60,70,80-CY1/W3
-	A50E5-40002	下水管 Hose	1	FD50,60,70,80-S3
-	A50F5-40002	下水管 Hose	1	FY50,60,70,80-G3
-	A50I5-40002	下水管 Hose	1	FY50,60,70,80-G4
5	GB/T5783	螺栓M8 \times 15 Bolt	3	
6	GB/T93	弹垫8 Washer,lock	3	
7	GB/T97.1	平垫8 Washer	5	
8	A50A5-40100	散热器备用罐 Tank reserve ass'y	1	
9	TG000-08185	橡胶管 $\phi 8\sim 1850$ Hose	1	
10	A30A5-40003	橡胶垫 I Rubber	2	
11	A30A5-40004	橡胶垫 II Rubber	2	
12	A30A5-40005	螺栓 Bolt	2	
13	A30A5-20003	垫片 Plate	2	
14	GB/T889.1	锁紧螺母 M8 Nut	2	
15	A50A5-40200	水箱总成 Radiator ass'y	1	FD50,60,70,80-CY1/W3
-	A50E5-40100	水箱总成 Radiator ass'y	1	FD50,60,70,80-S3
-	A50F5-40100	水箱总成 Radiator ass'y	1	FY50,60,70,80-G3/G4
16	A50A5-40210	护网 Retainer	1	FD50,60,70,80-CY1/W3 欧标车选用
-	A50E5-40110	护网 Retainer	1	FD50,60,70,80-S3 欧标车选用
17	GB/T5783	螺栓M8 \times 15 Bolt	4	欧标车选用
18	GB/T93	弹垫8 Washer,lock	4	欧标车选用

冷却系统
Cooling system

FD50,60,70,80-YC2

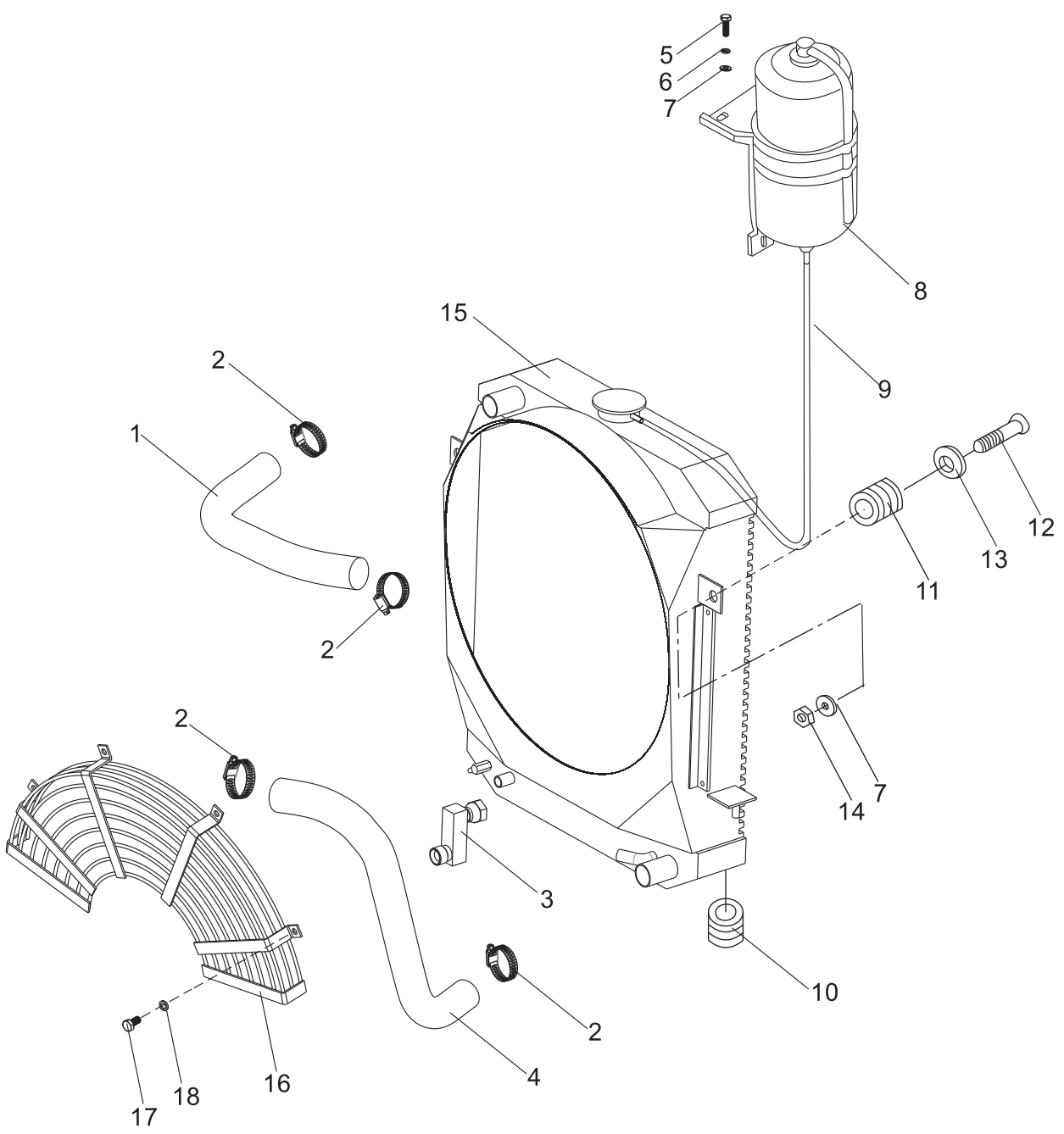

冷却系统
Cooling system

FD50,60,70,80-YC2

序号 Item	零件号 Part No	零部件名称 Description	数量 Q'ty	备注 Remark
1	A50G5-40001	上水管 Hose	1	
2	TK000-38057	卡箍 $\phi 38\sim 57$ Clip	4	
3	A50G5-40200	钢管接头 Pipe nipple	1	
4	A50G5-40002	下水管 Hose	1	
5	GB/T5783	螺栓M8 \times 15 Bolt	3	
6	GB/T93	弹垫8 Washer,lock	3	
7	GB/T97.1	平垫8 Washer	5	
8	A50A5-40100	散热器备用罐 Tank reserve ass'y	1	
9	TG000-08185	橡胶管 $\phi 8\times 1850$ Hose	1	
10	A30A5-40003	橡胶垫 I Rubber	2	
11	A30A5-40004	橡胶垫 II Rubber	2	
12	A30A5-40005	螺栓 Bolt	2	
13	A30A5-20003	垫片 Plate	2	
14	GB/T889.1	锁紧螺母 M8 Nut	2	
15	A50G5-40100	水箱总成 Radiator ass'y	1	
16	A50A5-40210	护网 Retainer	1	欧标车选用
17	GB/T5783	螺栓M8 \times 15 Bolt	4	欧标车选用
18	GB/T93	弹垫8 Washer,lock	4	欧标车选用

冷却系统
Cooling system

FD50,60,70,80-KMS2

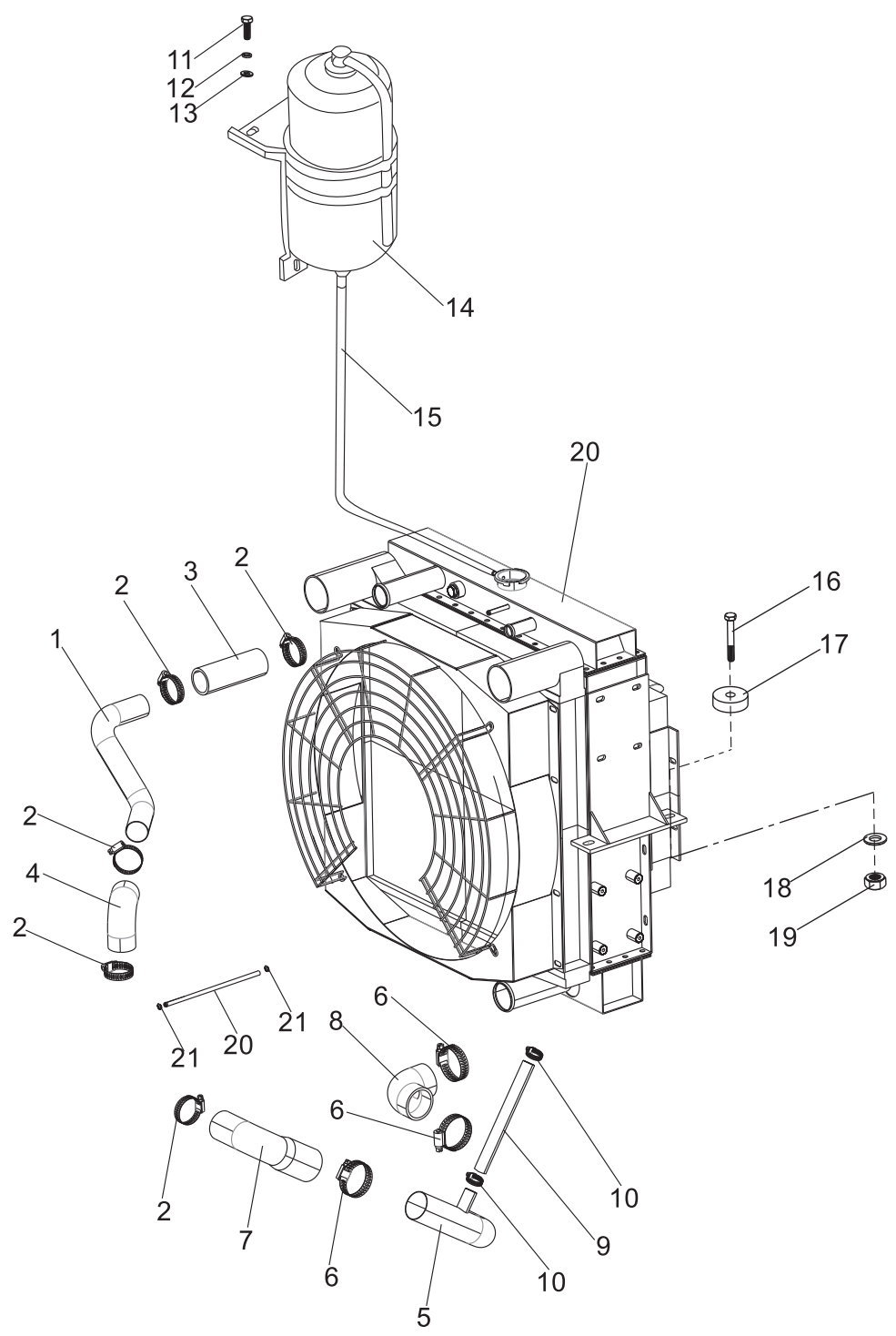

冷却系统
Cooling system

FD50,60,70,80-KMS2

序号 Item	零件号 Part No	零部件名称 Description	数量 Q'ty	备注 Remark
1	A90F5-40005	上水管 Hose	1	
2	TK000-44064	喉箍 $\phi 44\sim 64$ Clip	5	
3	A90F5-40004	连接胶管 Connect hose	1	
4	A90F5-40006	上水管接管 Hose	1	
5	A90F5-40001	下水管 Hose	1	
6	TK000-51070	喉箍 $\phi 51\sim 70$ Clip	3	
7	A90F5-40002	下水管接管I Hose	1	
8	A90F5-40003	下水管接管II Hose	1	
9	TG000-25150	橡胶管 $\phi 25\times 1500$ Hose	1	
10	TK000-25038	喉箍 $\phi 25\sim 38$ Clip	2	
11	GB/T5783	螺栓M8 \times 15 Bolt	3	
12	GB/T93	弹垫8 Washer,lock	3	
13	GB/T97.1	平垫8 Washer	3	
14	A50A5-40100	散热器备用罐 Tank reserve ass'y	1	
15	TG000-08100	橡胶管 $\phi 8\times 1000$ Hose	1	
16	GB/T5782	螺栓M12 \times 50 Bolt	4	
17	A30A5-20001	橡胶垫 Rubber	4	
18	GB/T97.1	平垫12 Washer	4	
19	GB/T889.1	锁紧螺母 M12 Nut	4	
20	A50K5-40100	水箱总成 Radiator ass'y	1	
21	TG000-08050	橡胶管 $\phi 8\times 500$ Hose	1	
22	TK000-10016	喉箍 $\phi 10\sim 16$ Clip	2	

燃油系统
Fuel system

FD50,60,70,80-CY1/W3/YC2/S3

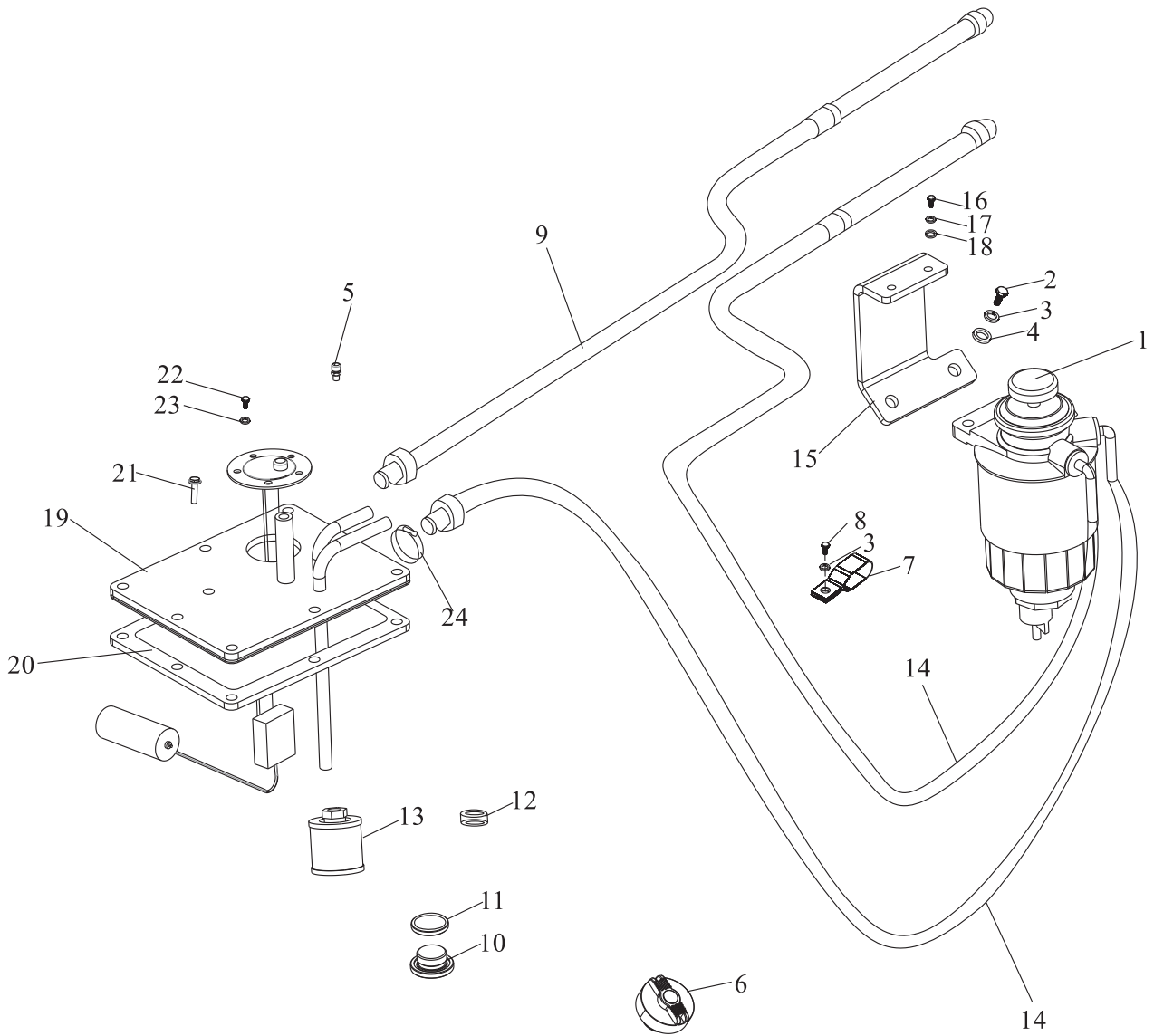

燃油系统
Fuel system

FD50,60,70,80-CY1/W3/YC2/S3

序号 Item	零件号 Part No	零部件名称 Description	数量 Q'ty	备注 Remark
1	A30A5-30300	油水分离器D×200MT Sedimenter	1	
2	GB/T5783	螺栓M10×20 Bolt	2	
3	GB/T93	弹垫10 Washer,Lock	3	
4	GB/T97.1	平垫10 Washer	2	
5	A45A5-30001	通气塞Z 1/8 " Cypriot ventilation	1	
6	A30A5-30100	加油盖 Cap	1	
7	D30A1-11008	管夹5 Clip	1	
8	GB/T5783	螺栓M10×15 Bolt	1	
9	TG000-10130	耐油胶管 φ10×1300 Tube	1	
10	A30A4-50002	放油螺塞 Plug,drain	1	
11	A30A4-50004	ED密封圈26 Washer	1	
12	A30A4-50003	磁铁 Magnet	2	
13	A30A5-30400	柴油滤清器 Sedimenter	1	
14	TG000-10200	耐油胶管 φ10×2000 Tube	2	
15	A50C5-30001	油水分离器支架 Sedimenter bracket	1	
16	GB/T5783	螺栓 M8×25 Bolt	2	
17	GB/T93	弹垫 8 Washer,Lock	2	
18	GB/T97.1	平垫 8 Washer	2	
19	A50A5-30300	盖板总成 Plate	1	
20	A50A5-30001	盖板垫 Packing	1	
21	GB/T5787	六角法兰面螺栓 M8×16 Bolt	8	
22	GB/T818	十字伞头螺栓M5×12 Bolt	5	
23	GB/T93	弹垫5 Washer,Lock	5	
24	TK000-13019	喉箍 φ13-φ19 Clip	6	

燃油系统
Fuel system

FD50,60,70,80-KMS2

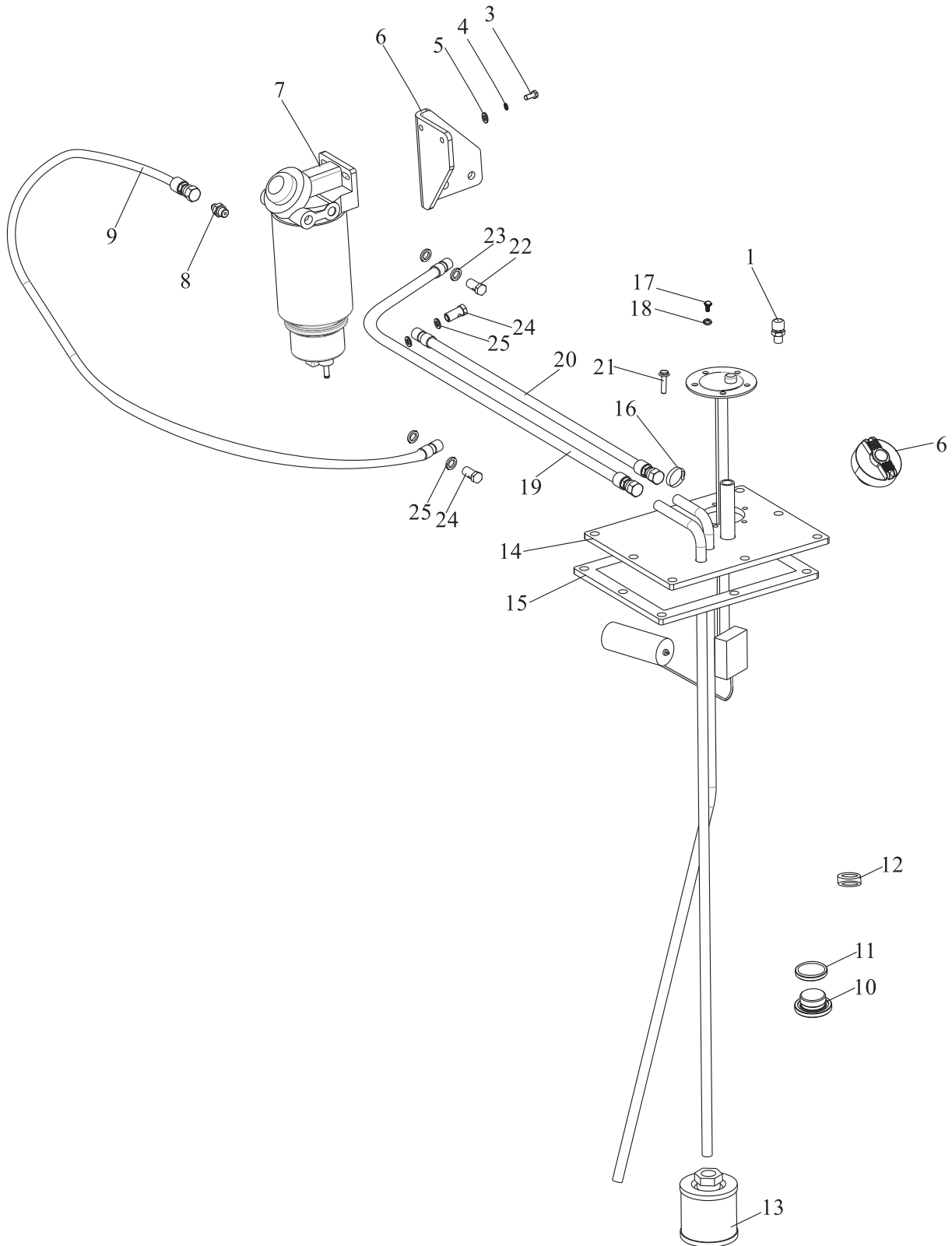

燃油系统
Fuel system

FD50,60,70,80-KMS2

序号 Item	零件号 Part No	零部件名称 Description	数量 Q'ty	备注 Remark
1	A45A5-30001	通气塞Z 1/8 " Cypriot ventilation	1	
2	A30A5-30100	加油盖 Cap	1	
3	GB/T5783	螺栓M8×30 Bolt	2	
4	GB/T93	弹垫8 Washer,Lock	2	
5	GB/T97.1	平垫8 Washer	2	
6	A90F5-30001	油水分离器支架 Sedimenter bracket	1	
7	A90F5-30006	接头 Joint	1	
8	A90F5-30100	油水分离器 Sedimenter	1	
9	A90F5-30003	供油管II Tube	1	
10	A30A4-50002	放油螺塞 Plug,drain	1	
11	A30A4-50004	ED密封圈26 Washer	1	
12	A30A4-50003	磁铁 Magnet	2	
13	A30A5-30400	柴油滤清器 Sedimenter	1	
14	A90C5-30100	盖板总成 Plate	1	
15	A50A5-30001	盖板垫 Packing	1	
16	TK000-13019	喉箍 φ 13-φ 19 Clip	4	
17	GB/T818	十字伞头螺栓M5×12 Bolt	5	
18	GB/T93	弹垫5 Washer,Lock	5	
19	A90F5-30002	供油管I Tube	1	
20	A90F5-30007	回油管 Tube	1	
21	GB/T5787	六角法兰面螺栓 M8×20 Bolt	8	
22	A90F5-30004	空心螺栓M14 Bolt	1	
23	JB982	组合垫14 Packing	2	
24	A90F5-30005	空心螺栓M12 Bolt	2	
25	JB982	组合垫12 Packing	4	

排气系统
Exhaust system

FD50,60,70,80-CY1/W3

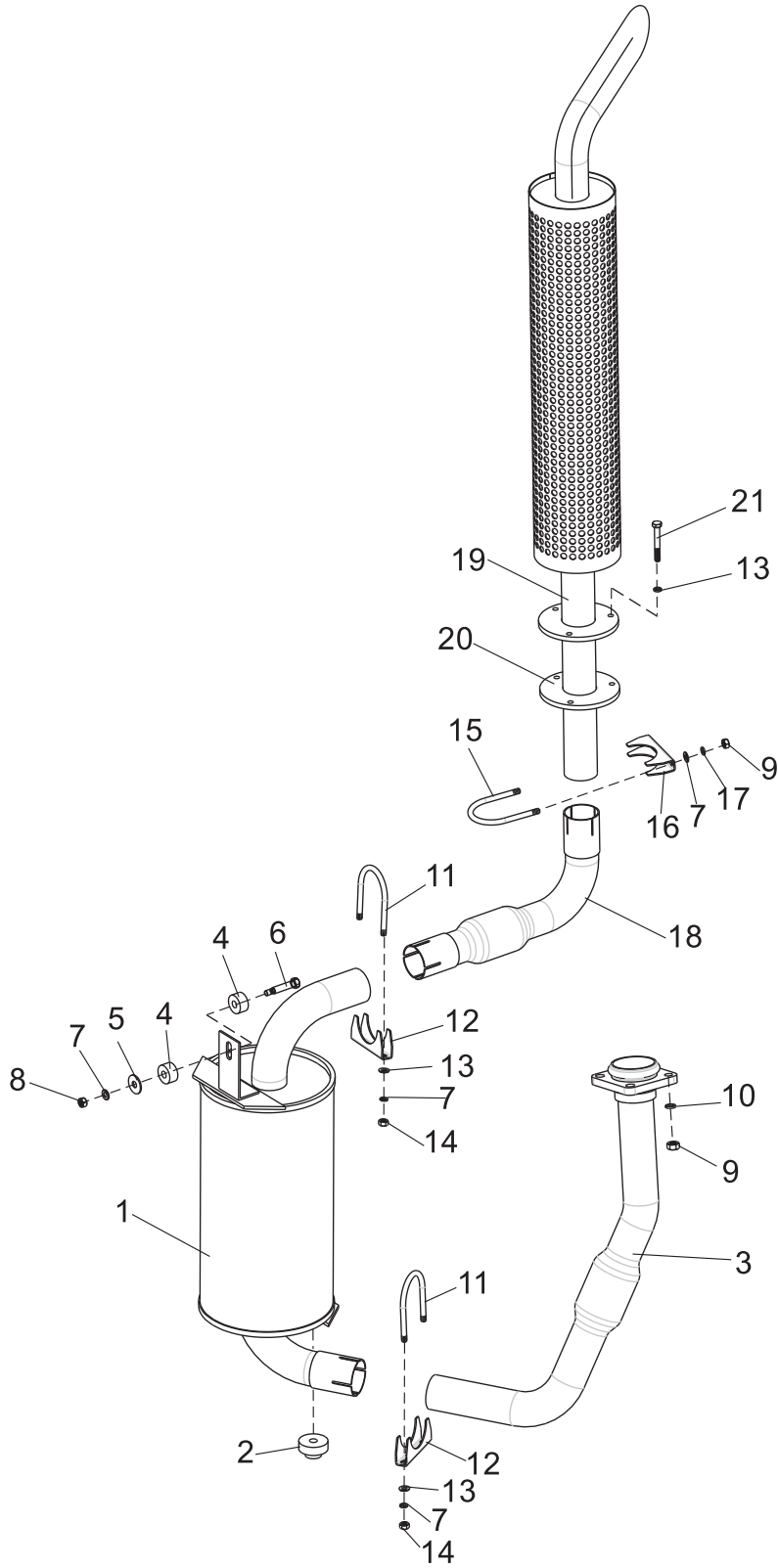

排气系统
Exhaust system

FD50,60,70,80-CY1/W3

序号 Item	零件号 Part No	零部件名称 Description	数量 Q'ty	备注 Remark
1	A50C5-20300	消声器总成 Muffler	1	
2	A30A5-40003	橡胶垫 I Rubber	1	
3	A50A5-20100	前排气管总成 Front pipe ass'y	1	
4	A30A5-20001	橡胶垫 Rubber	2	
5	A30A5-20003	垫片 Washer	1	
6	A30A5-20002	螺栓 Bolt	1	
7	GB/T97.1	平垫8 Washer	5	
8	GB/T889.1	锁紧螺母 M8 Nut	1	
9	GB/T6170	螺母 M10 Nut	8	
10	GB/T93	弹垫 10 Washer, lock	8	
11	A50A5-20202	U型螺栓 U-Bolt	2	
12	A50A5-20201	卡板 Stopper	2	
13	GB/T93	弹垫8 Washer, lock	7	
14	GB/T6170	螺母 M8 Nut	4	
15	A90C5-20502	U型螺栓 U-Bolt	1	
16	A90C5-20501	卡板 Stopper	1	
17	GB/T97.1	平垫10 Washer	2	
18	A50C5-20100	排气接管 Exhaust takeover	1	
19	A90D1-20100	高位排气管 High exhaust	1	
20	A50C5-10005	橡胶垫 Rubber pad	1	
21	GB/T5783	螺栓M8×25 Bolt	3	

排气系统
Exhaust system

FD50,60,70,80-S3

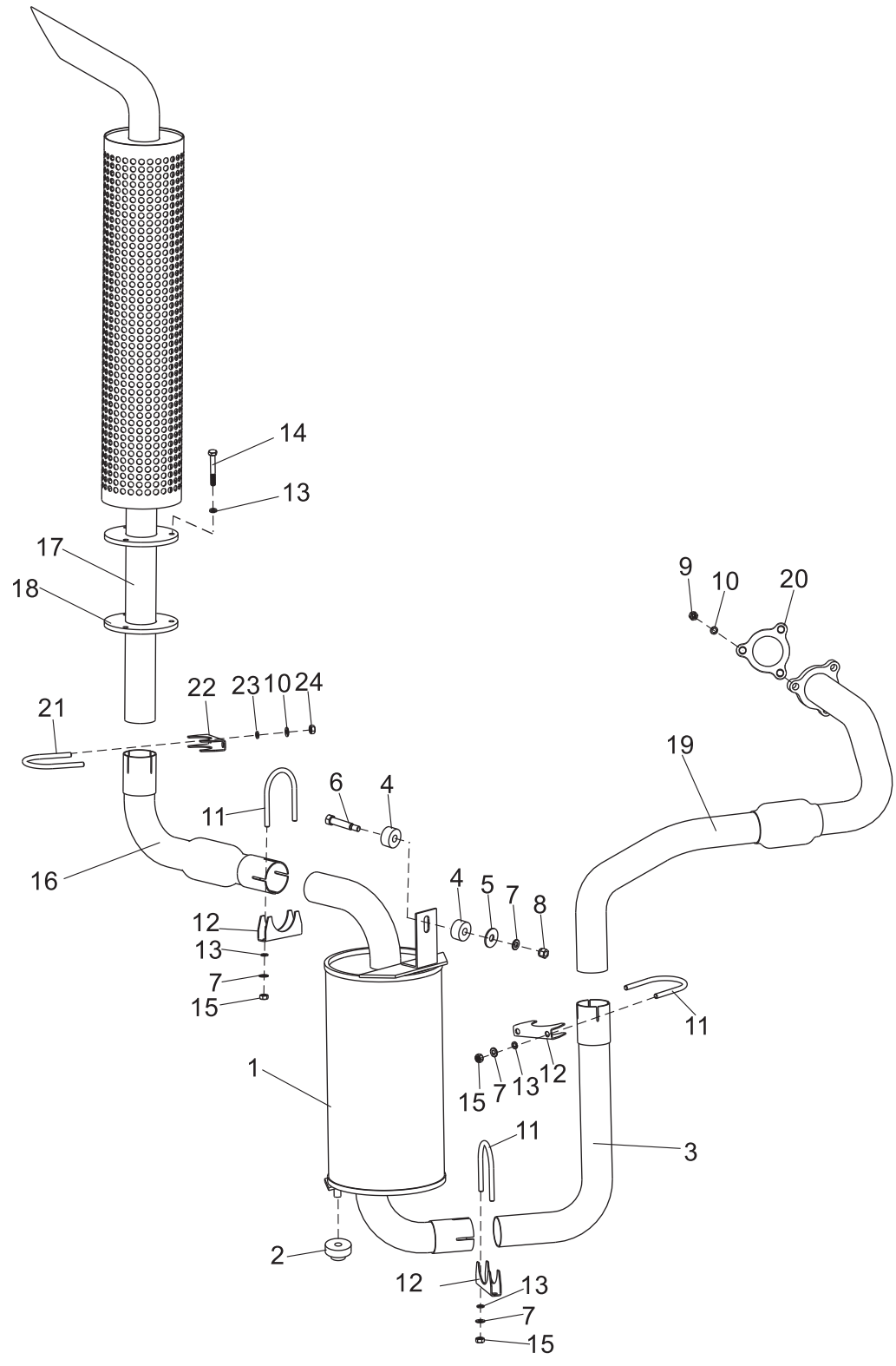

排气系统
Exhaust system

FD50,60,70,80-S3

序号 Item	零件号 Part No	零部件名称 Description	数量 Q'ty	备注 Remark
1	A50E5-20200	消声器总成 Muffler	1	
2	A30A5-40003	橡胶垫 I Rubber	1	
3	A50E5-20001	排气接管 Exhaust takeover	1	
4	A30A5-20001	橡胶垫 Rubber	2	
5	A30A5-20003	垫片 Washer	1	
6	A30A5-20002	螺栓 Bolt	1	
7	GB/T97.1	平垫8 Washer	7	
8	GB/T889.1	锁紧螺母 M8 Nut	1	
9	GB/T6171	螺母 M10×1.25 Nut	3	
10	GB/T93	弹垫 10 Washer, lock	5	
11	A50A5-20202	U型螺栓 U-Bolt	3	
12	A50A5-20201	卡板 Stopper	3	
13	GB/T93	弹垫8 Washer, lock	9	
14	GB/T5783	螺栓M8×25 Bolt	3	
15	GB/T6170	螺母 M8 Nut	6	
16	A50C5-20100	排气接管 Exhaust takeover	1	
17	A90D1-20100	高位排气管 High exhaust	1	
18	A50C5-10005	橡胶垫 Rubber pad	1	
19	A50E5-20100	排气管总成 Pipe ass'y	1	
20	A50E5-20002	排气管垫 Rubber	1	
21	A90C5-20502	U型螺栓 U-Bolt	1	
22	A90C5-20501	卡板 Stopper	1	
23	GB/T97.1	平垫10 Washer	2	
24	GB/T6170	螺母 M10 Nut	2	

排气系统
Exhaust system

FD50,60,70,80-YC2

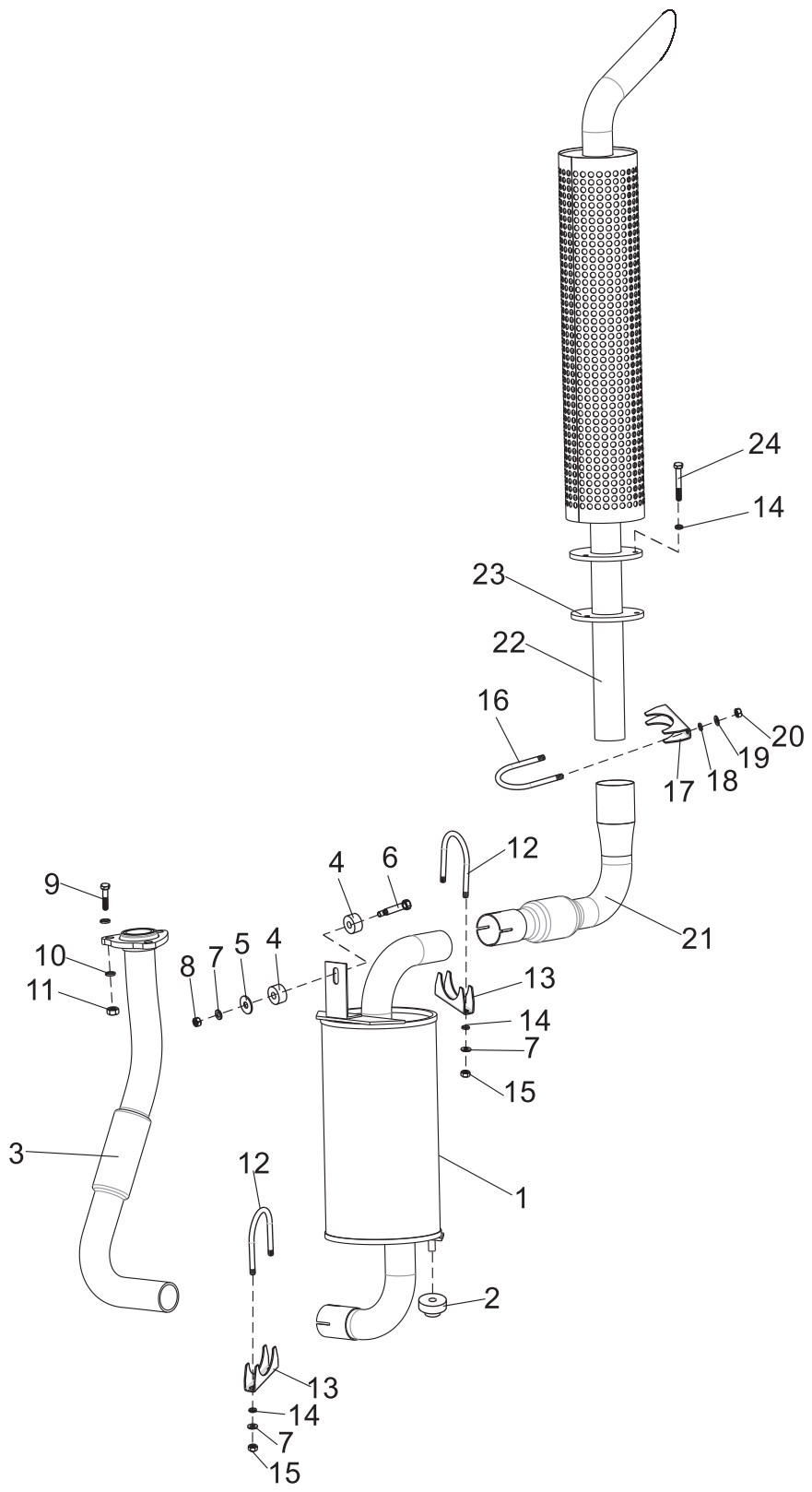

排气系统
Exhaust system

FD50,60,70,80-YC2

序号 Item	零件号 Part No	零部件名称 Description	数量 Q'ty	备注 Remark
1	A50G5-20300	消声器总成 Muffler	1	
2	A30A5-40003	橡胶垫 I Rubber	1	
3	A50G5-20100	前排气管总成 Front pipe ass'y	1	
4	A30A5-20001	橡胶垫 Rubber	2	
5	A30A5-20003	垫片 Washer	1	
6	A30A5-20002	螺栓 Bolt	1	
7	GB/T97.1	平垫8 Washer	5	
8	GB/T889.1	锁紧螺母 M8 Nut	1	
9	GB/T5783	螺栓M12×40 Bolt	3	
10	GB/T93	弹垫 12 Washer, lock	6	
11	GB/T6170	螺母 M12 Nut	3	
12	A50A5-20202	U型螺栓 U-Bolt	2	
13	A50A5-20201	卡板 Stopper	1	
14	GB/T93	弹垫8 Washer, lock	7	
15	GB/T6170	螺母 M8 Nut	4	
16	A90C5-20502	U型螺栓 U-Bolt	1	
17	A90C5-20501	卡板 Stopper	1	
18	GB/T93	弹垫 10 Washer, lock	2	
19	GB/T97.1	平垫10 Washer	2	
20	GB/T6170	螺母 M10 Nut	2	
21	A50C5-20100	排气接管 Exhaust takeover	1	
22	A90D1-20100	高位排气管 High exhaust	1	
23	A50C5-10005	橡胶垫 Rubber pad	1	
24	GB/T5783	螺栓M8×25 Bolt	3	

排气系统
Exhaust system

FD50,60,70,80-KMS2

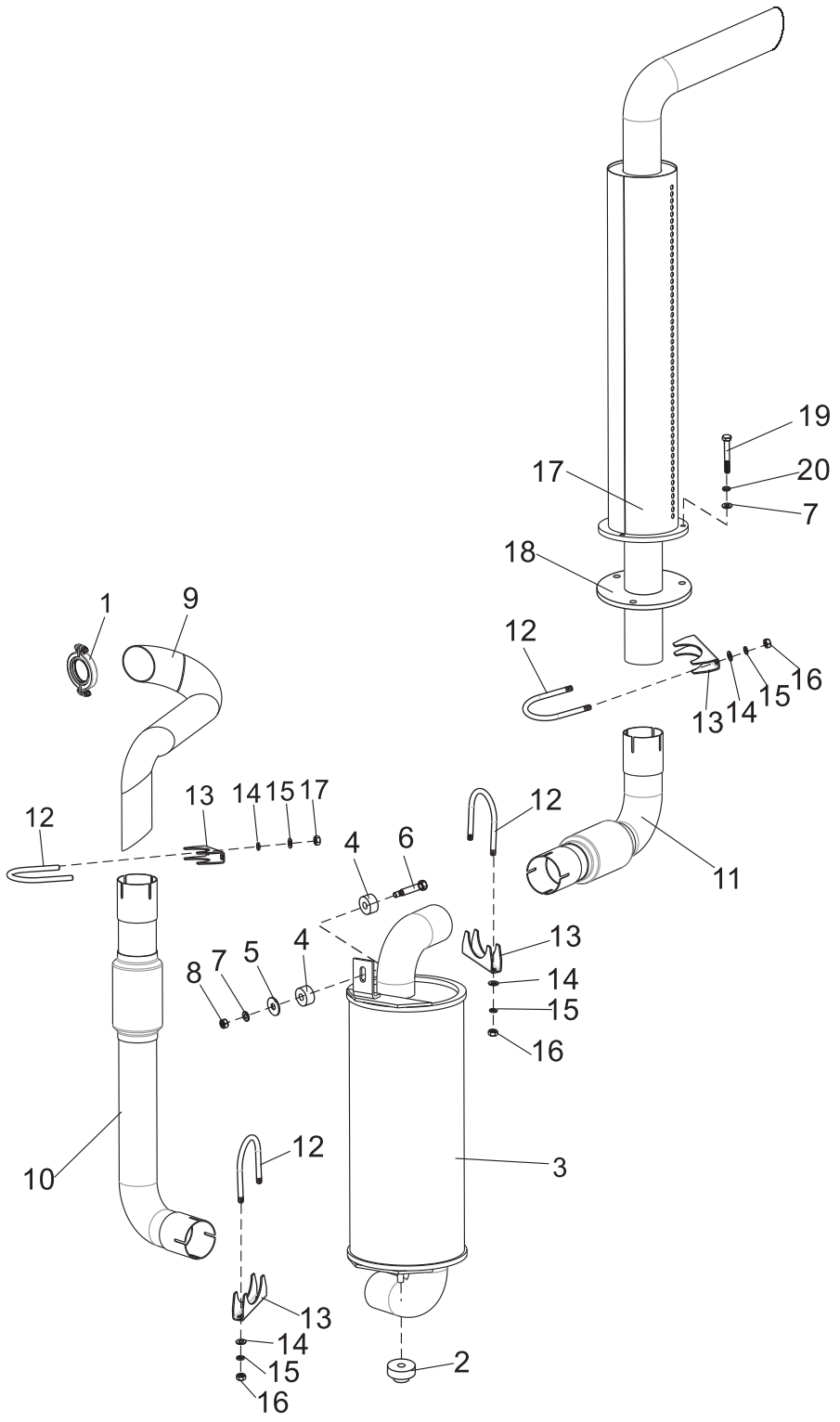

排气系统
Exhaust system

FD50,60,70,80-KMS2

序号 Item	零件号 Part No	零部件名称 Description	数量 Q'ty	备注 Remark
1	A120A5-20001	管卡(V型) Pipe clamp (V)	1	
2	A30A5-40003	橡胶垫 I Rubber	2	
3	A50K5-20100	消声器总成 Muffler	1	
4	A30A5-20001	橡胶垫 Rubber	2	
5	A30A5-20003	垫片 Washer	1	
6	A30A5-20002	螺栓 Bolt	1	
7	GB/T97.1	平垫8 Washer	4	
8	GB/T889.1	锁紧螺母 M8 Nut	1	
9	A50K5-20200	排气管 Exhaust pipe	1	
10	A50K5-2300	排气接管I Exhaust takeover	1	
11	A50K5-20400	排气接管II Exhaust takeover	1	
12	A120A5-20502	U型螺栓 U-Bolt	3	
13	A120A5-20501	卡板 Stopper	3	
14	GB/T93	弹垫10 Washer, lock	6	
15	GB/T97.1	平垫10 Washer	6	
16	GB/T6170	螺母 M10 Nut	6	
17	A120A5-20600	高位排气管 High exhaust	1	
18	A50C5-10005	橡胶垫 Rubber pad	1	
19	GB/T5783	螺栓M8×20 Bolt	3	
20	GB/T93	弹垫8 Washer, lock	3	

排气系统
Exhaust system

FY50,60,70,80-G3

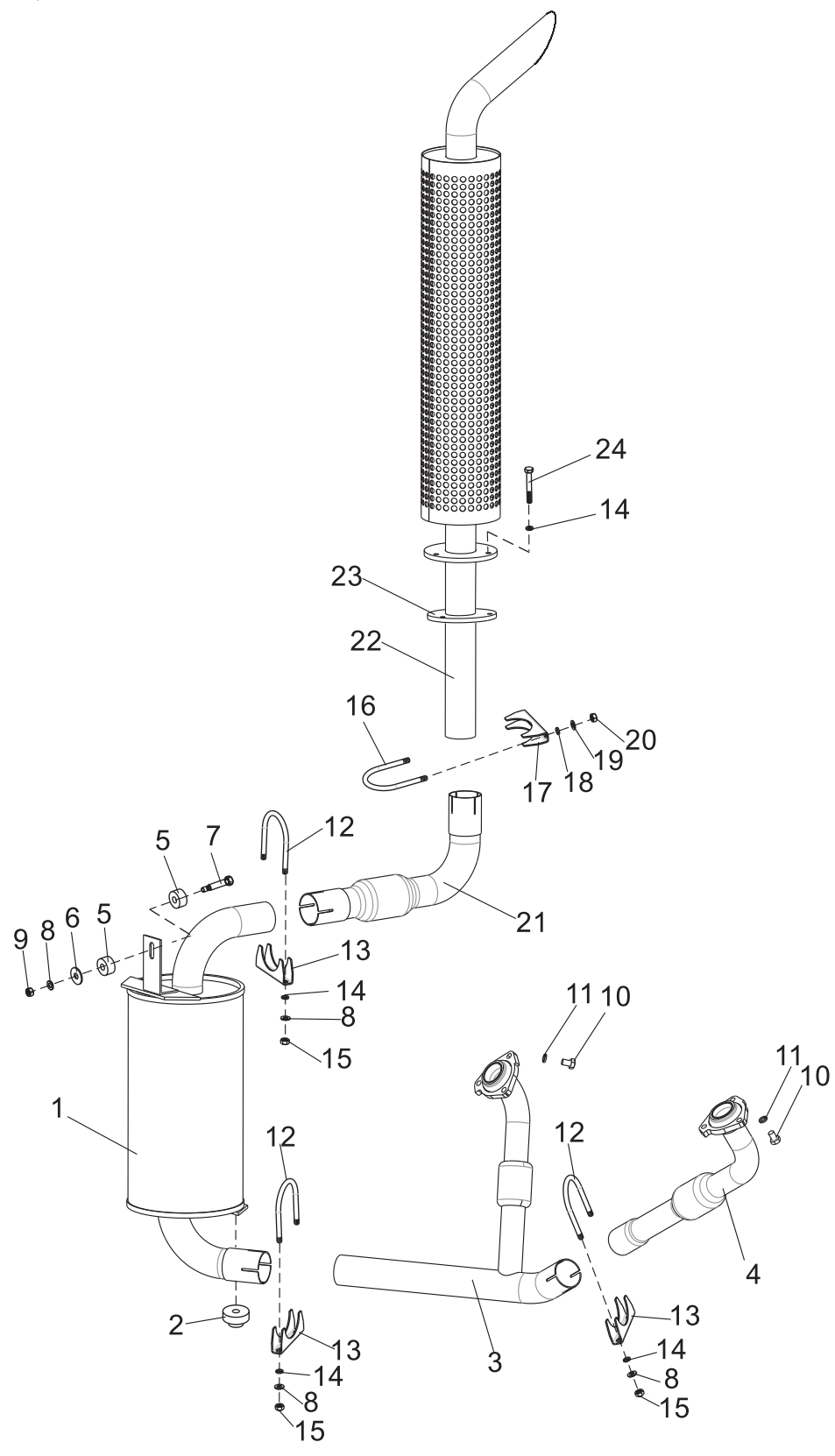

排气系统
Exhaust system

FY50,60,70,80-G3

序号 Item	零件号 Part No	零部件名称 Description	数量 Q'ty	备注 Remark
1	A50F5-20300	消声器总成 Muffler	1	
2	A30A5-40003	橡胶垫 I Rubber	1	
3	A50F5-20200	前排气管右管总成 Front pipe ass'y	1	
4	A50F5-20100	前排气管左管总成 Front pipe ass'y	1	
5	A30A5-20001	橡胶垫 Rubber	2	
6	A30A5-20003	垫片 Washer	1	
7	A30A5-20002	螺栓 Bolt	1	
8	GB/T97.1	平垫8 Washer	7	
9	GB/T889.1	锁紧螺母 M8 Nut	1	
10	GB/T5786	螺栓M10×1.5×25 Bolt	6	
11	GB/T93	弹垫 10 Washer, lock	6	
12	A50A5-20202	U型螺栓 U-Bolt	3	
13	A50A5-20201	卡板 Stopper	3	
14	GB/T93	弹垫8 Washer, lock	9	
15	GB/T6170	螺母 M8 Nut	6	
16	A90C5-20502	U型螺栓 U-Bolt	1	
17	A90C5-20501	卡板 Stopper	1	
18	GB/T93	弹垫 10 Washer, lock	2	
19	GB/T97.1	平垫10 Washer	2	
20	GB/T6170	螺母 M10 Nut	2	
21	A50C5-20100	排气接管 Exhaust takeover	1	
22	A90D1-20100	高位排气管 High exhaust	1	
23	A50C5-10005	橡胶垫 Rubber pad	1	
24	GB/T5783	螺栓M8×25 Bolt	3	

排气系统
Exhaust system

FY50,60,70,80-G4

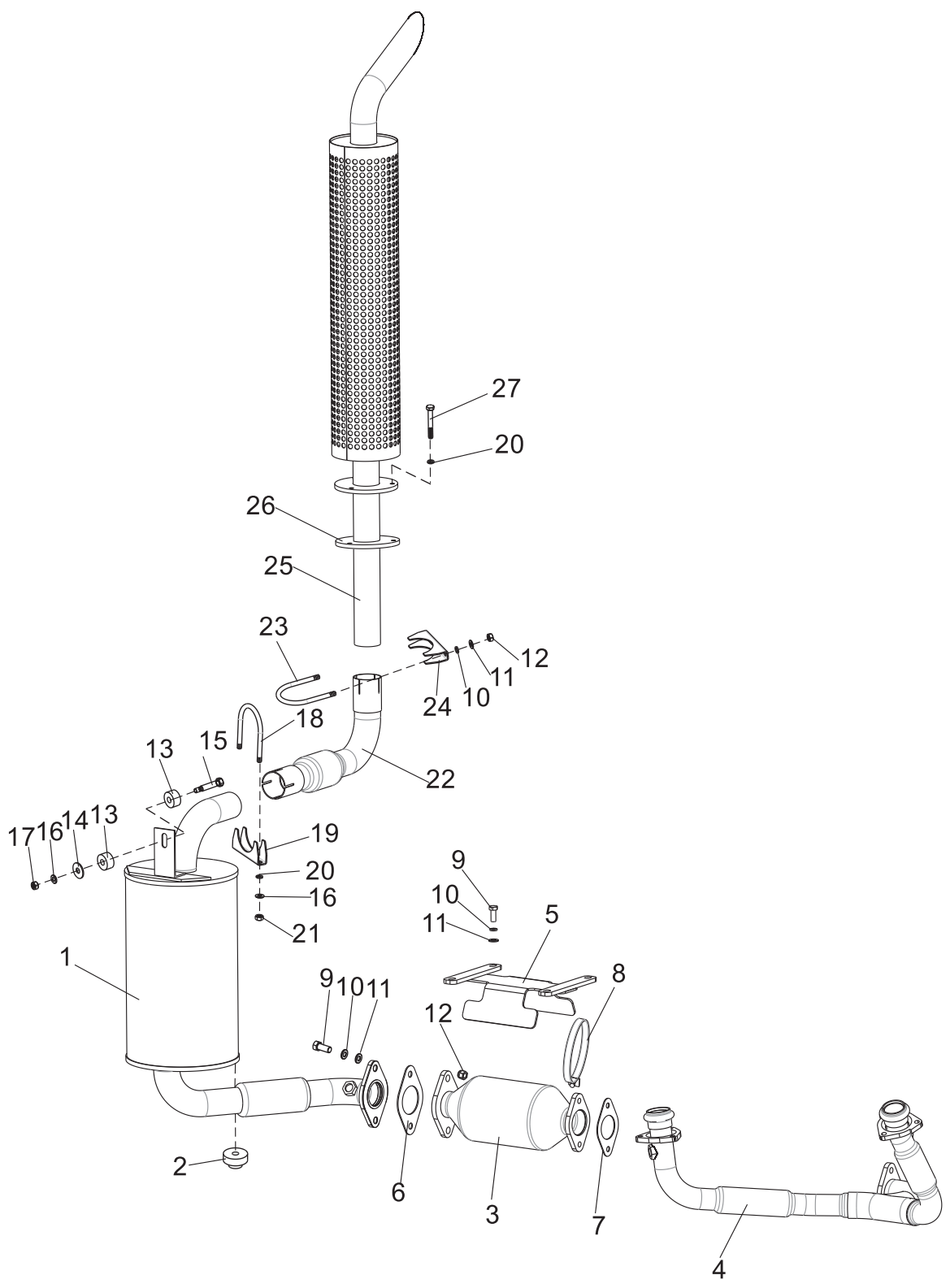

排气系统
Exhaust system

FY50,60,70,80-G4

序号 Item	零件号 Part No	零部件名称 Description	数量 Q'ty	备注 Remark
1	A50I5-20100	消声器总成 Muffler	1	发动机自带
2	A30A5-40003	橡胶垫 I Rubber	1	
3		三元催化器 Three-way catalyst	1	
4	A50I5-20600	排气管总成 Pipe ass'y	1	
5	A50I5-20200	催化器固定板总成 Fixed plate	1	
6	A50I5-20002	垫片 Washer	1	
7	A50I5-20001	垫片 Washer	1	
8	TK000-130150	卡箍130-150 Clamp	2	
9	GB/T5786	螺栓M10×25 Bolt	8	
10	GB/T93	弹垫 10 Washer, lock	10	
11	GB/T97.1	平垫10 Washer	10	
12	GB/T6170	螺母 M10 Nut	6	
13	A30A5-20001	橡胶垫 Rubber	2	
14	A30A5-20003	垫片 Washer	1	
15	A30A5-20002	螺栓 Bolt	1	
16	GB/T97.1	平垫8 Washer	3	
17	GB/T889.1	锁紧螺母 M8 Nut	1	
18	A50A5-20202	U型螺栓 U-Bolt	1	
19	A50A5-20201	卡板 Stopper	1	
20	GB/T93	弹垫8 Washer, lock	5	
21	GB/T6170	螺母 M8 Nut	2	
22	A50C5-20100	排气接管 Exhaust takeover	1	
23	A90C5-20502	U型螺栓 U-Bolt	1	
24	A90C5-20501	卡板 Stopper	1	
25	A90D1-20100	高位排气管 High exhaust	1	
26	A50C5-10005	橡胶垫 Rubber pad	1	
27	GB/T5783	螺栓M8×25 Bolt	3	

变矩器冷却系统
Tor-con oil cooling system

FD50,60,70,80-CY1/W3/S3/YC2
FY50,60,70,80-G3/G4

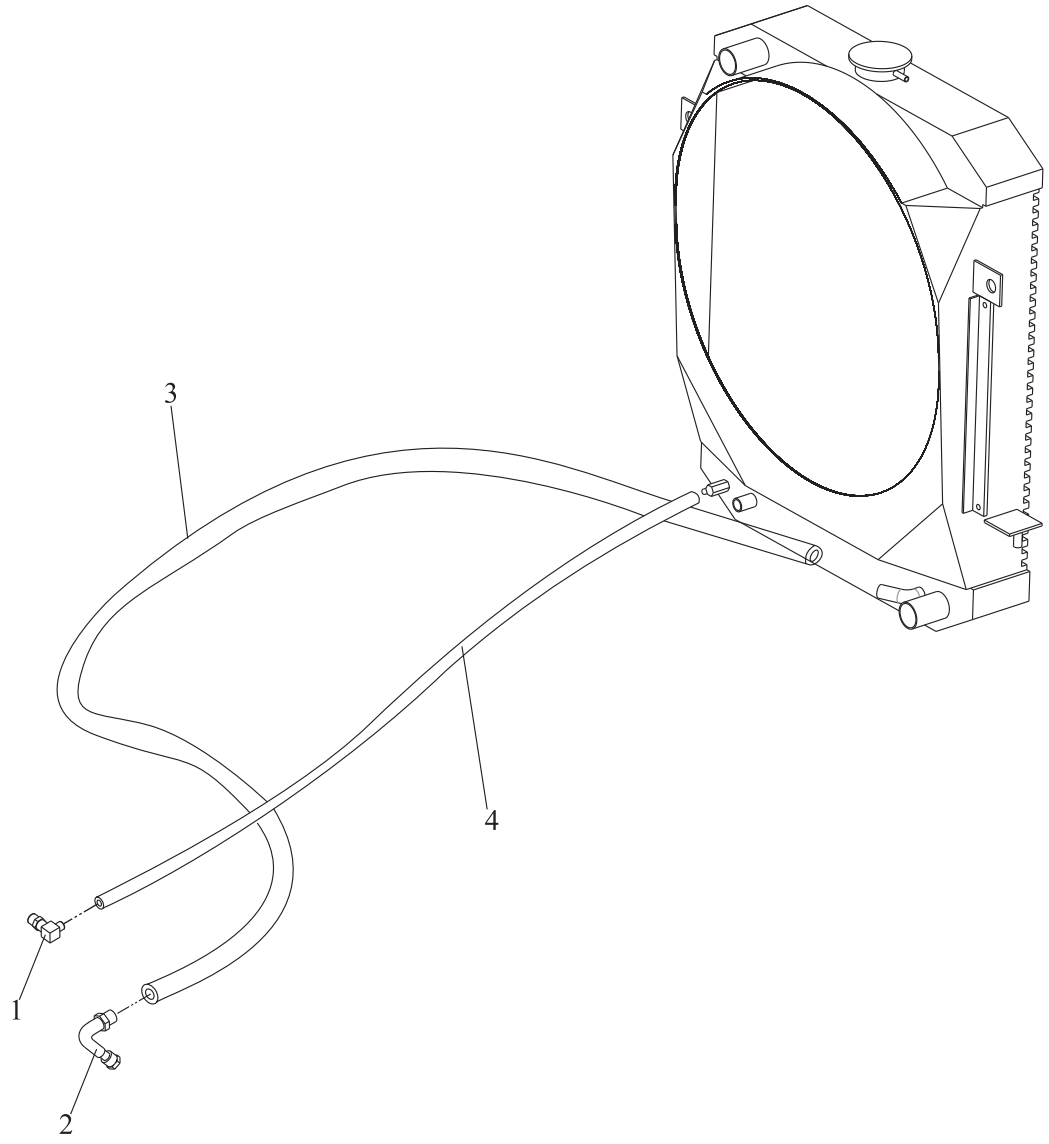

变矩器冷却系统
Tor-con oil cooling system

FD50,60,70,80-CY1/W3/S3/YC2
FY50,60,70,80-G3/G4

序号 Item	零件号 Part No	零部件名称 Description	数量 Q'ty	备注 Remark
1	GJT-374-00	直角接头 Nipple	1	
2	GJT-414-00	135° 接头 Nipple	1	
3	TG000-19143*G	回油管 $\phi 19 \times 1430$ Hose	1	FD/Y50,60,70,80-CY1/W3/S3/YC2/G3
-	TG000-19130*G	回油管 $\phi 19 \times 1300$ Hose	1	FY50,60,70,80-G4
4	TG000-19245*G	回油管 $\phi 19 \times 2450$ Hose	1	FD/Y50,60,70,80-CY1/W3/S3/YC2/G3
-	TG000-19215*G	回油管 $\phi 19 \times 2150$ Hose	1	FY50,60,70,80-G4

变矩器冷却系统
Tor-con oil cooling system

FD50,60,70,80-KMS2

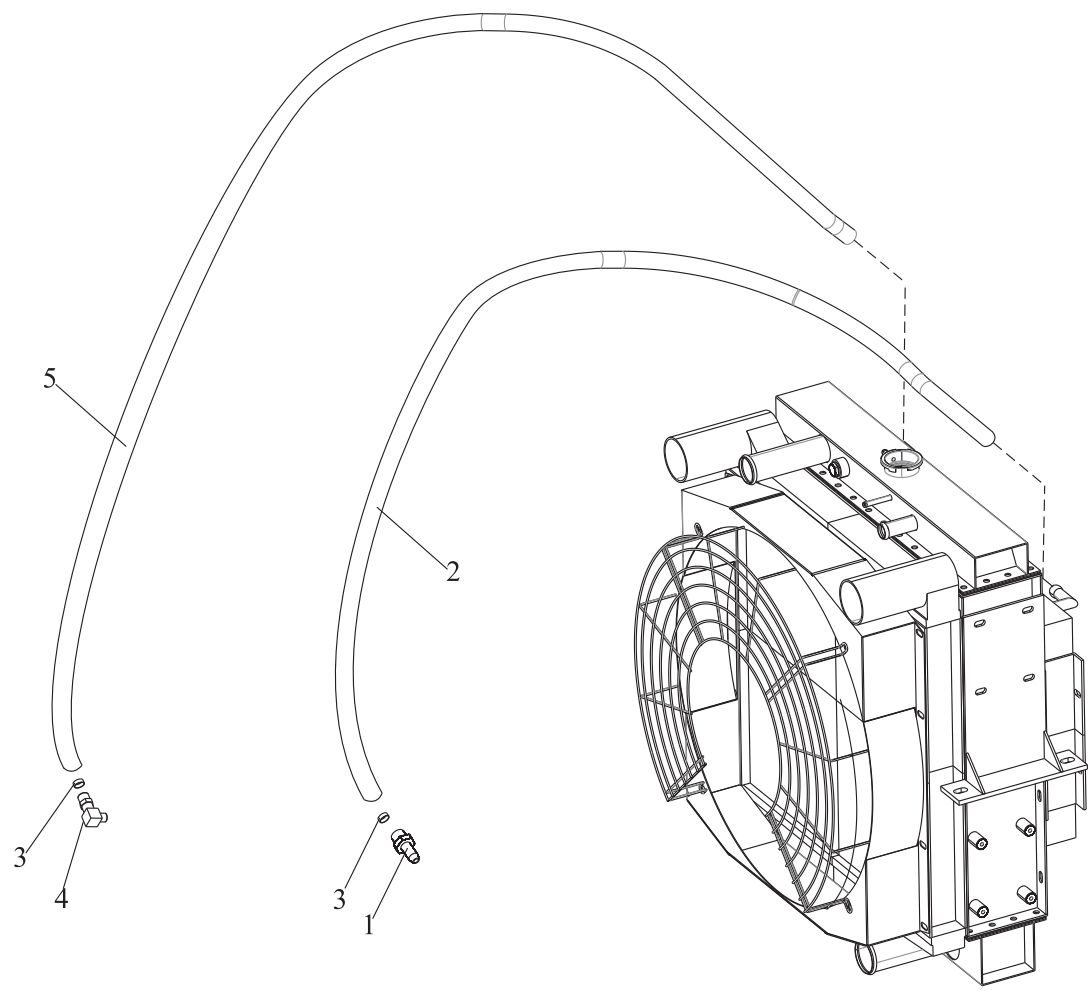

变矩器冷却系统
Tor-con oil cooling system

FD50,60,70,80-KMS2

序号 Item	零件号 Part No	零部件名称 Description	数量 Q'ty	备注 Remark
1	GJT-111-00	直通接头 Nipple	1	
2	TG000-19250	回油管 $\phi 19 \times 2500$ Hose	1	
3	TK000-16025	喉箍 $\phi 16-25$ Clamp	4	
4	GJT-104-00	直角接头 Nipple	1	
5	TG000-19200	回油管 $\phi 19 \times 2000$ Hose	1	

二、传动系统

DRIVING SYSTEM

減速器和差速器
Reduction&Differential

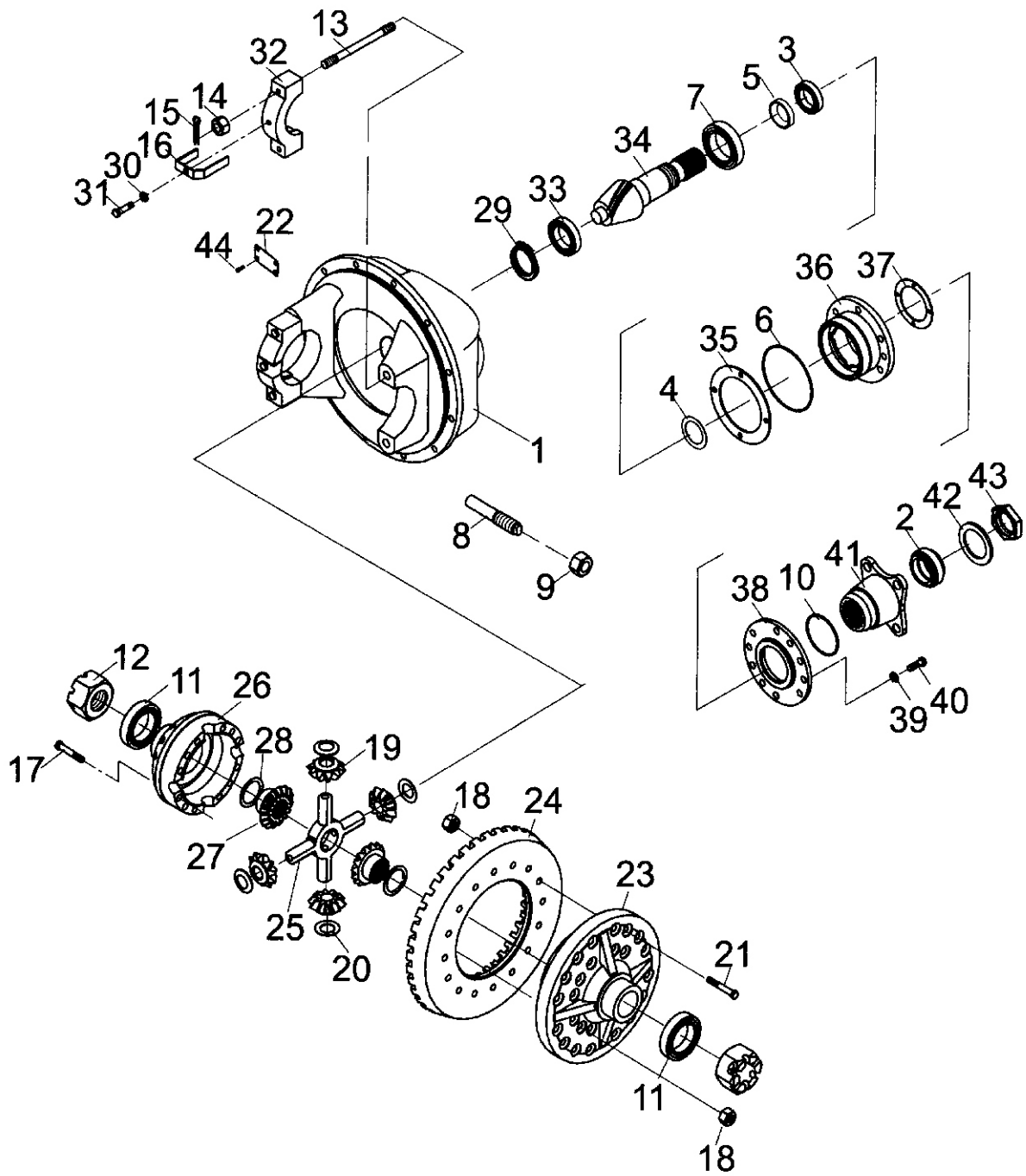

减速器和差速器 Reduction&Differential

序号 Item	零件号 Part No	零部件名称 Description	数量 Q'ty	备注 Remark
A	A50A5-00700	差速器总成 Differential unit	1	
1	A50A5-00701	主传动器壳体 Carrier	1	
2	A50A5-00702	油封SG70×95×12 Oil seal	1	
3	GB/T297	轴承27310E Bearing	1	
4	A50A5-00703	调整垫片 Washer, thrust	按需 AR	
5	A50A5-00704	隔块 Piece distance	1	
6	GB/T1235	O形密封圈140X3.1 O-ring	1	
7	GB/T297	轴承2731E Bearing	1	
8	A50A5-00705	调整螺柱总成 Bolt ass'y	1	
9	GB/T6173-2000	螺母M22×1.5 Nut	1	
10	GB/T1235	O形圈40.64×5.34 O-ring	1	
11	GB/T297	轴承7514E Bearing	2	
12	A50A5-00706	调整螺母 Nut	2	
13	A50A5-00707	盖用双头螺栓 Bolt	4	
14	A50A5-00708	螺母 Nut	4	
15	GB/T91	销4×40 Pin cotter	4	
16	A50A5-00709	锁片 Lock adjuster	2	
17	A50A5-00710	螺栓 Bolt	8	
18	GB/T6171	螺母M14×1.5 Nut	20	
19	A50A5-00711	行星齿轮 Gear, planet	4	
20	A50A5-00712	推力垫片 Washer, thrust	4	
21	A50A5-00713	螺栓 Bolt	12	
22	A50A5-00714	差速器总成标牌 Decal	1	
23	A50A5-00715	差速器左壳体 Case, L. H. cross	1	
24	A50A5-00716	大螺伞齿轮 Gear	1	

減速器和差速器
Reduction&Differential

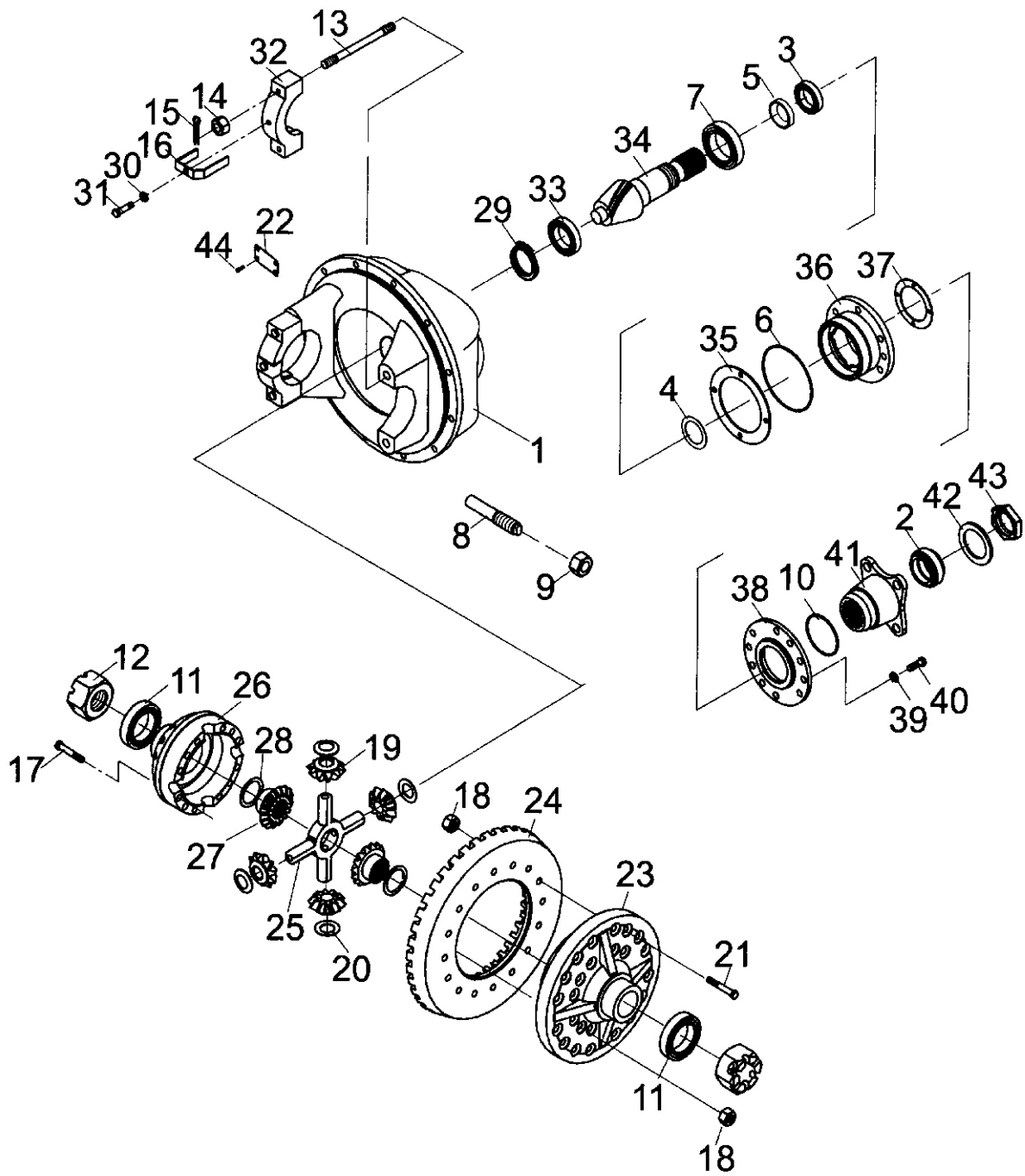

减速器和差速器 Reduction&Differential

序号 Item	零件号 Part No	零部件名称 Description	数量 Q'ty	备注 Remark
25	A50A5-00718	十字轴 Spider	1	
26	A50A5-00719	差速器右壳体 Case, R. H. cross	1	
27	A50A5-00720	半轴齿轮 Gear side	2	
28	A50A5-00721	调整垫片 Washer, adjuster	按需 AR	
29	GB/T894. 1	轴用弹性挡圈30 Snap ring	1	
30	GB/T93	弹垫10 Washer, lock	2	
31	GB/T5786	螺栓M10×1. 25×20 Bolt	2	
32	A50A5-00722	轴承盖 Cap	2	
33	A50A5-00723	滚珠轴承 Bearing taper roller	1	
34	A50A5-00724	主动螺旋伞齿轮 Pinion drive	1	
35	A50A5-00725	调整垫片 Washer, thrust	按需 AR	
36	A50A5-00726	轴承座 Case	1	
37	A50A5-00727	衬垫 Packing	1	
38	A50A5-00728	油封座 Retainer oil seal	1	
39	GB/T93	弹垫14 Washer, lock	6	
40	GB/T5785	螺栓M14×1. 5×50 Bolt	6	
41	A50A5-00730	凸缘 Flang, companion	1	
42	A50A5-00731	垫圈 Washer	1	
43	A50A5-00732	锁紧螺母 Lock nut	1	
44	GB/T827	铆钉3×4 Rivet	4	

传动装置安装 Drive unit mount

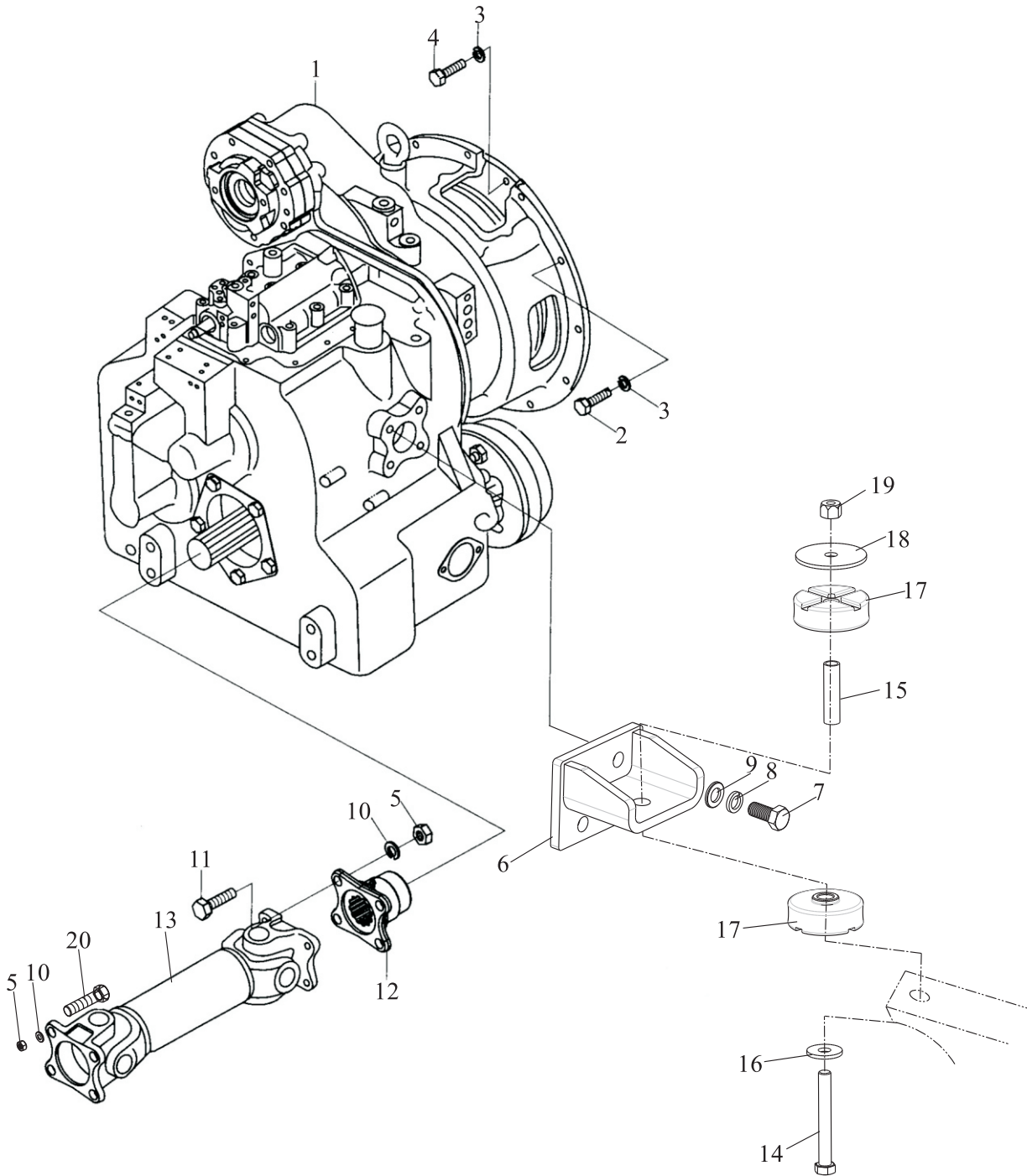

传动装置安装 Drive unit mount

序号 Item	零件号 Part No	零部件名称 Description	数量 Q'ty	备注 Remark
1	A50A5-00400	电液变速箱总成 Drive unit	1	FD50,60,70,80-CY1/W3
-	A50A5-00800	手液变速箱总成 Drive unit	1	FD50,60,70,80-CY1/W3
-	A50E5-00100	电液变速箱总成 Drive unit	1	FD50,60,70,80-S3
-	A50E5-00300	手液变速箱总成 Drive unit	1	FD50,60,70,80-S3
-	A50G5-00100	电液变速箱总成 Drive unit	1	FD50,60,70,80-YC2
-	A50F5-00100	电液变速箱总成 Drive unit	1	FY50,60,70,80-G3/G4
-	A90F5-00100	电液变速箱总成 Drive unit	1	FD50,60,70,80-KMS2
-	A90F5-00200	手液变速箱总成 Drive unit	1	FD50,60,70,80-KMS2
2	GB/T5783	螺栓 M10×30 Bolt	12	FD50,60,70,80-CY1/W3/S3/YC2
-	GB/T5783	螺栓 M10×35 Bolt	10	FY50,60,70,80-G3/G4
-	GB/T5783	螺栓 M10×45 Bolt	12	FD50,60,70,80-KMS2
3	GB/T93	弹垫10 Washer, lock	22	FD/Y50,60,70,80-CY1/W3/S3/YC2/G3/G4
-	GB/T93	弹垫10 Washer, lock	16	FD50,60,70,80-KMS2
4	GB/T5783	螺栓 M10×25 Bolt	10	
-	ANSIB1.1	螺栓 3/8-16UNC×3/4" Bolt	6	
5	GB/T6171	螺母M14×1.5 Nut	8	
6	A50A5-00500	变速箱支架 Bracket, drive	2	
7	GB/T5786	螺栓M16×1.5×35 Bolt	8	
8	GB/T93	弹垫16 Washer, lock	8	
9	GB/T97.1	平垫16 Washer	8	
10	GB/T93	弹垫14 Washer, lock	8	
11	A50A5-00001	铰制螺栓 Bolt	8	FD50,60,70,80-CY1/W3
-	A50A5-00001	铰制螺栓 Bolt	4	FD50,60,70,80-S3/YC2
12	A50A5-00401	联接套 Joint bushing	1	
13	A50A5-00300	传动轴总成 Propeller shaft ass'y	1	
14	GB/T5782	螺栓M14×110×30 Bolt	2	

传动装置安装 Drive unit mount

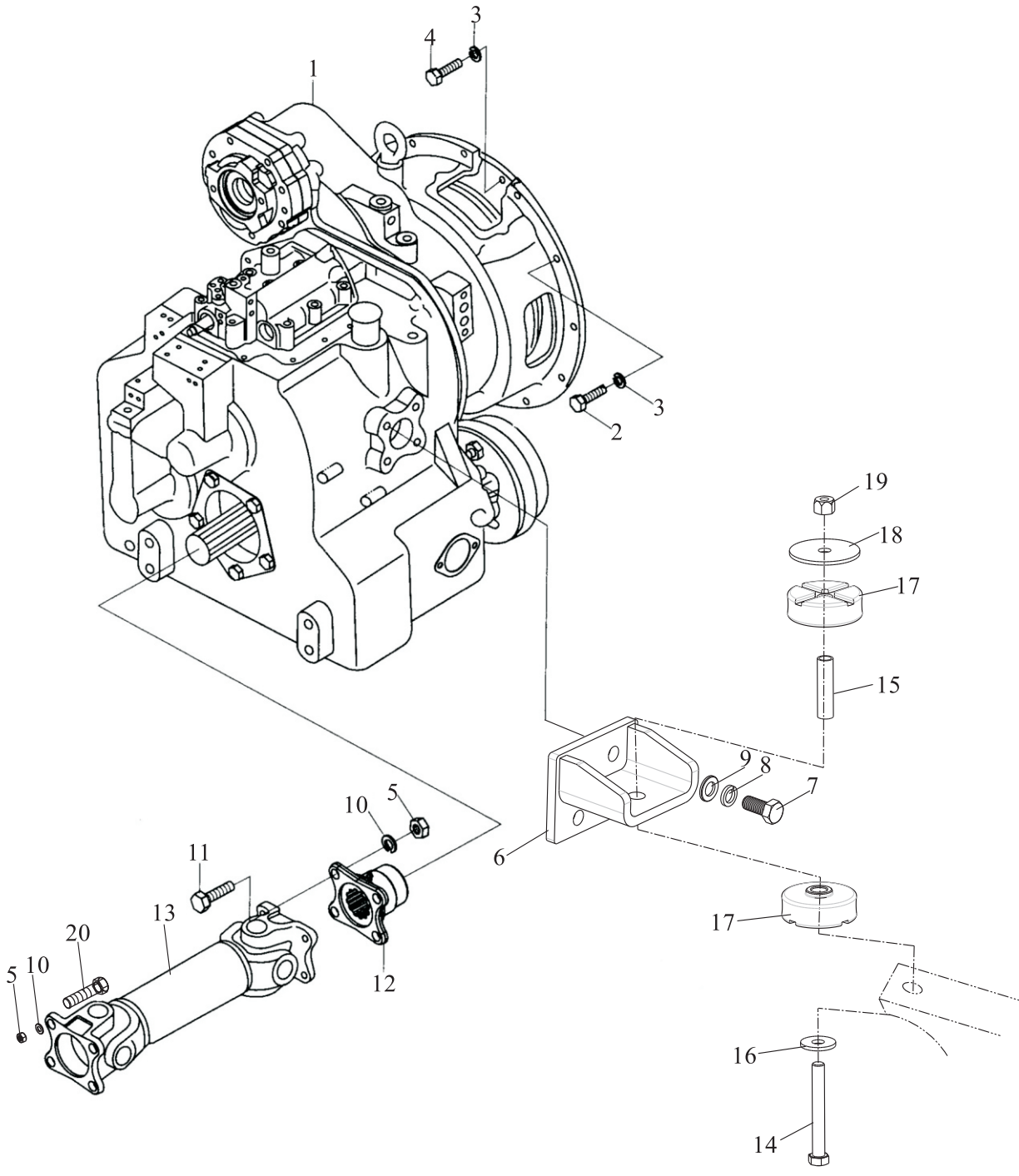

传动装置安装
Drive unit mount

序号 Item	零件号 Part No	零部件名称 Description	数量 Q'ty	备注 Remark
15	A50C5-00103	套管 Plastic pipe	2	
16	A50C5-00102	垫片 Shim	2	
17	A50C5-00101	橡胶垫 Cushion, rubber	4	
18	A50C5-00104	垫片 Shim	2	
19	GB/T6186	全金属六角锁紧螺母M14 Nut	2	
20	A50A5-00006	铰制螺栓 Bolt	4	FD50,60,70,80-S3/YC2

传动装置
Drive unit

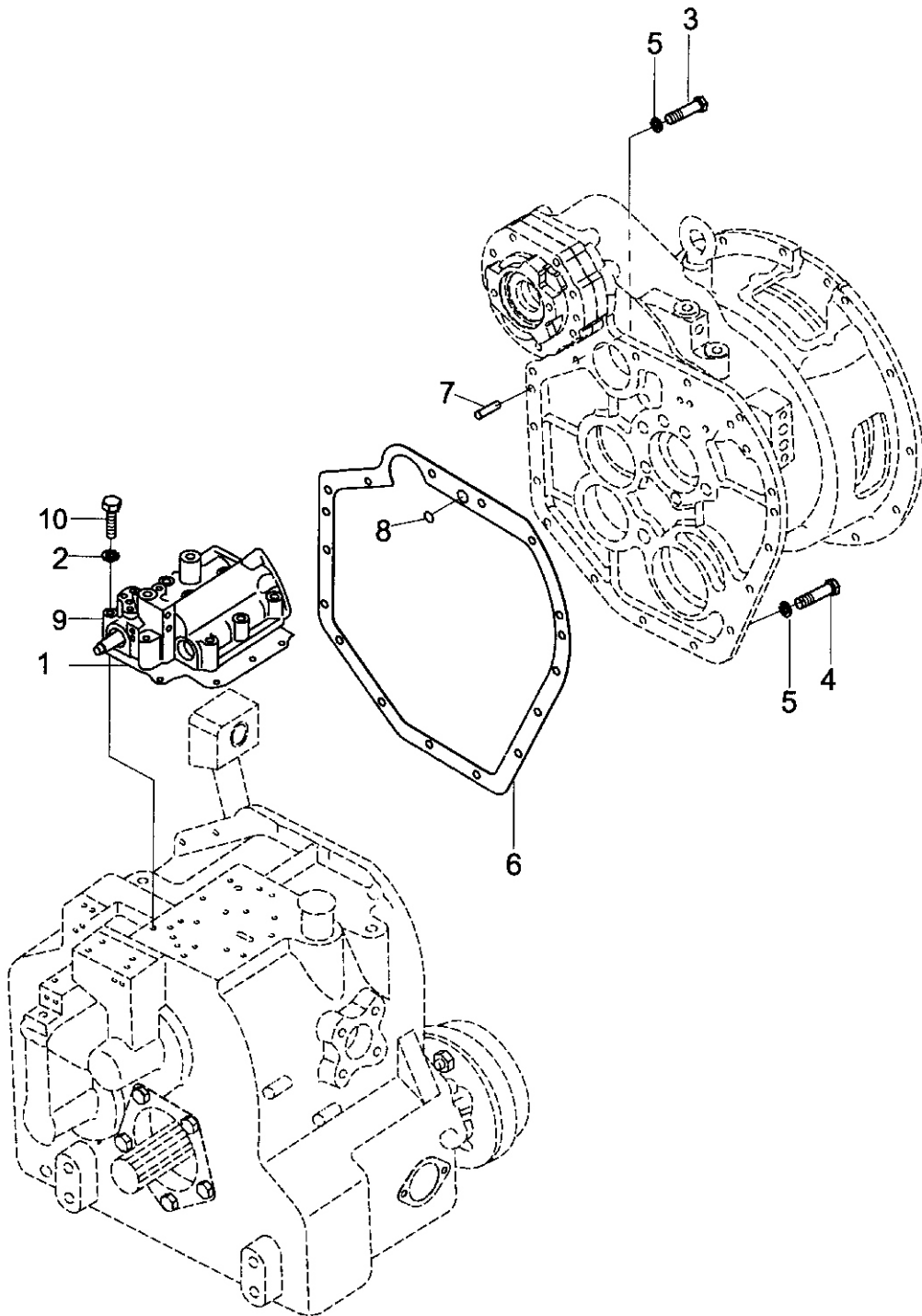

传动装置
Drive unit

序号 Item	零件号 Part No	零部件名称 Description	数量 Q'ty	备注 Remark
1	A50A5-00402	垫片 Gasket	1	
2	GB/T93-1987	弹垫8 Washer, lock	9	
3	GB/T5785	螺栓M10×1.25×65 Bolt	1	
4	GB/T5785	螺栓M10×1.25×30 Bolt	11	
5	GB/T93	弹垫10 Washer, lock	12	
6	A50A5-00403	垫 Gasket	1	
7	GB/T119.1	销 B10×20 Pin	2	
8	GB/T1235	O形圈15×2.4 O-ring	1	
9	A50A5-00600	控制阀总成 Control valve ass'y	1	
10	GB/T5782	螺栓M8×55 Bolt	9	

变矩器 (1/2)
Torque-converter (1/2)

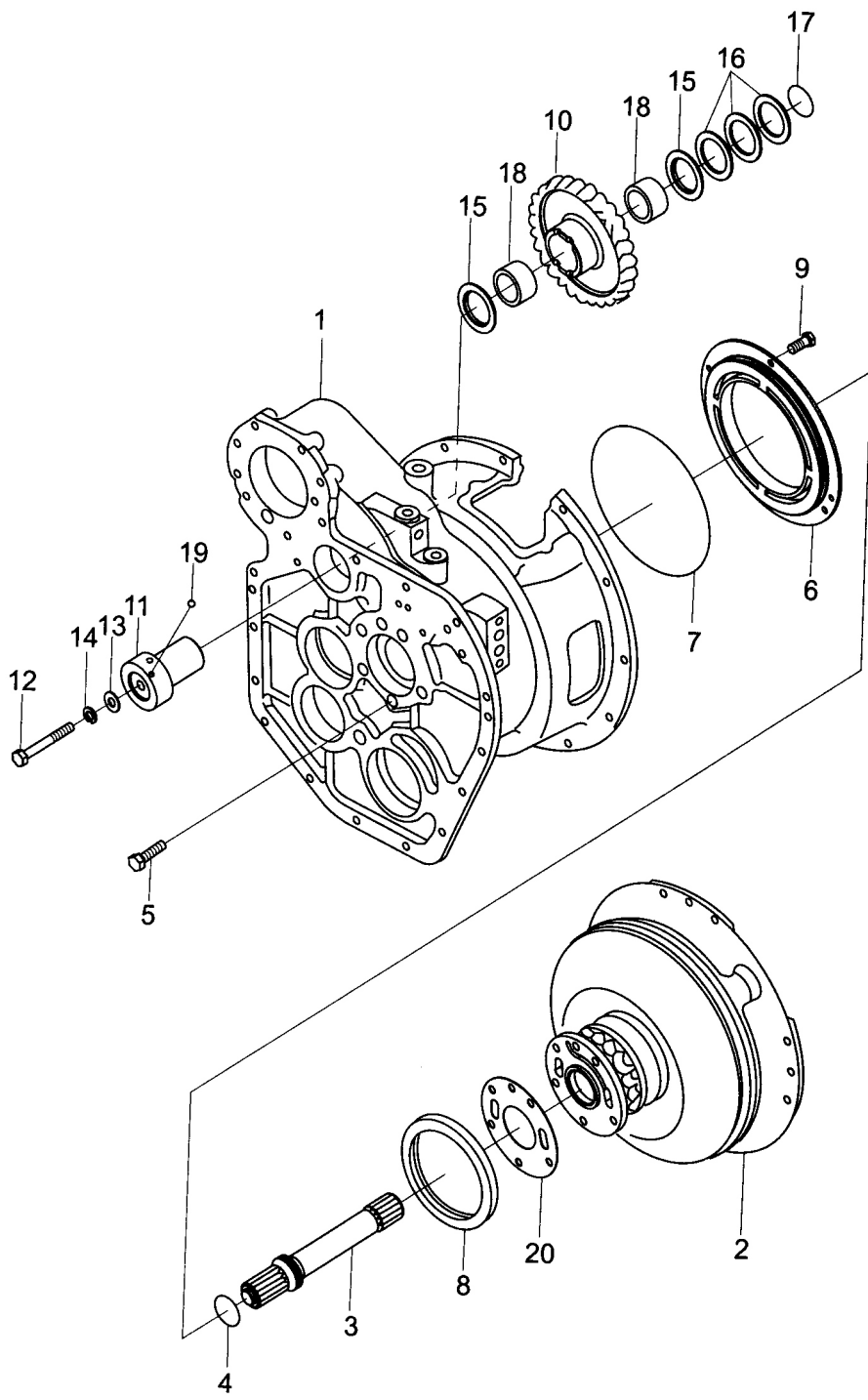

变矩器 (1/2)

Torque-converter (1/2)

序号 Item	零件号 Part No	零部件名称 Description	数量 Q'ty	备注 Remark
1	A50A5-03001	变矩器壳 Case, tor-con	1	
2	A50A5-03000	变矩器总成 Tor-con ass't	1	
3	A50A5-03002	涡轮轴 Shaft, turbin	1	
4	A50A5-03003	密封环 Ring, sed	1	
5	GB/T70	螺钉M10×50 Screw	6	
6	A50A5-03004	后盖 Back cover	1	
7	GB/T1235	O形圈220×5.7 O-ring	1	
8	A50A5-03005	油封SG130×60×15 Oil seal	1	
9	GB/T5785	螺栓M8×1×15 Bolt	3	
10	A50A5-03006	惰轮Gear	1	
11	A50A5-03007	惰轮支承 Supper	1	
12	A50A5-03008	螺栓 Bolt	1	
13	GB/T97. 1	平垫10 Washer	1	
14	GB/T93	弹垫10 Washer, lock	1	
15	A50A5-03009	推力滚针轴承 Bearing	2	
16	A50A5-03010	止推垫圈 Washer	3	
17	A50A5-03011	调整垫片 Shim	2	
18	A50A5-03012	滚针轴承 Bearing	2	
19	GB/T308	钢球1/4" Ball, steel	1	
20	A50A5-03013	变矩器垫 Gasket	1	

变矩器 (2/2)
Torque-converter (2/2)

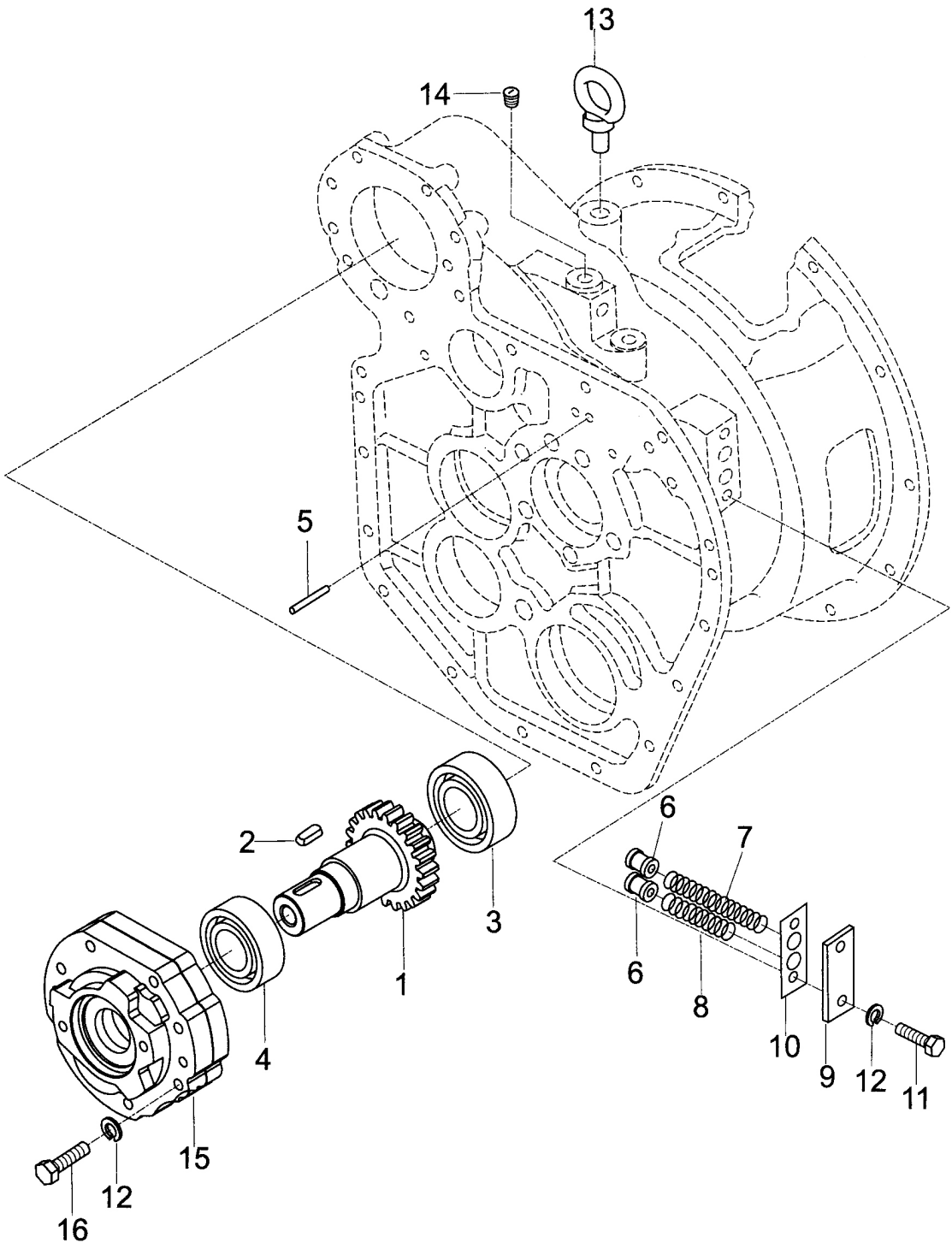

变矩器 (2/2)

Torque-converter (2/2)

序号 Item	零件号 Part No	零部件名称 Description	数量 Q'ty	备注 Remark
1	A50A5-03014	泵传动齿轮 Gear, drive	1	
2	A50A5-03015	键 Key	1	
3	A50A5-03016	轴承 Bearing	1	
4	GB/T276	轴承209 Bearing	1	
5	A50A5-03017	圆柱销 Pin, paraller	2	
6	A50A5-03018	活塞 Piston	2	
7	A50A5-03019	弹簧 Spring	1	
8	A50A5-03020	弹簧 Sping	1	
9	A50A5-03021	盖板 Cover	1	
10	A50A5-03022	垫片 Gasket	1	
11	GB/T5785	螺栓M10×1.25×35 Bolt	2	
12	GB/T93	弹垫10 Washer, lock	9	
13	GB/T825	吊环螺钉M16 Eye screw	3	
14	A50A5-03023	螺塞(3/8") Plug	2	
15	A50A5-03100	供油泵 Charging pump	1	
16	GB/T5785	螺栓M10×1.25×60 Bolt	7	

变速箱 (1/2)
Transmission (1/2)

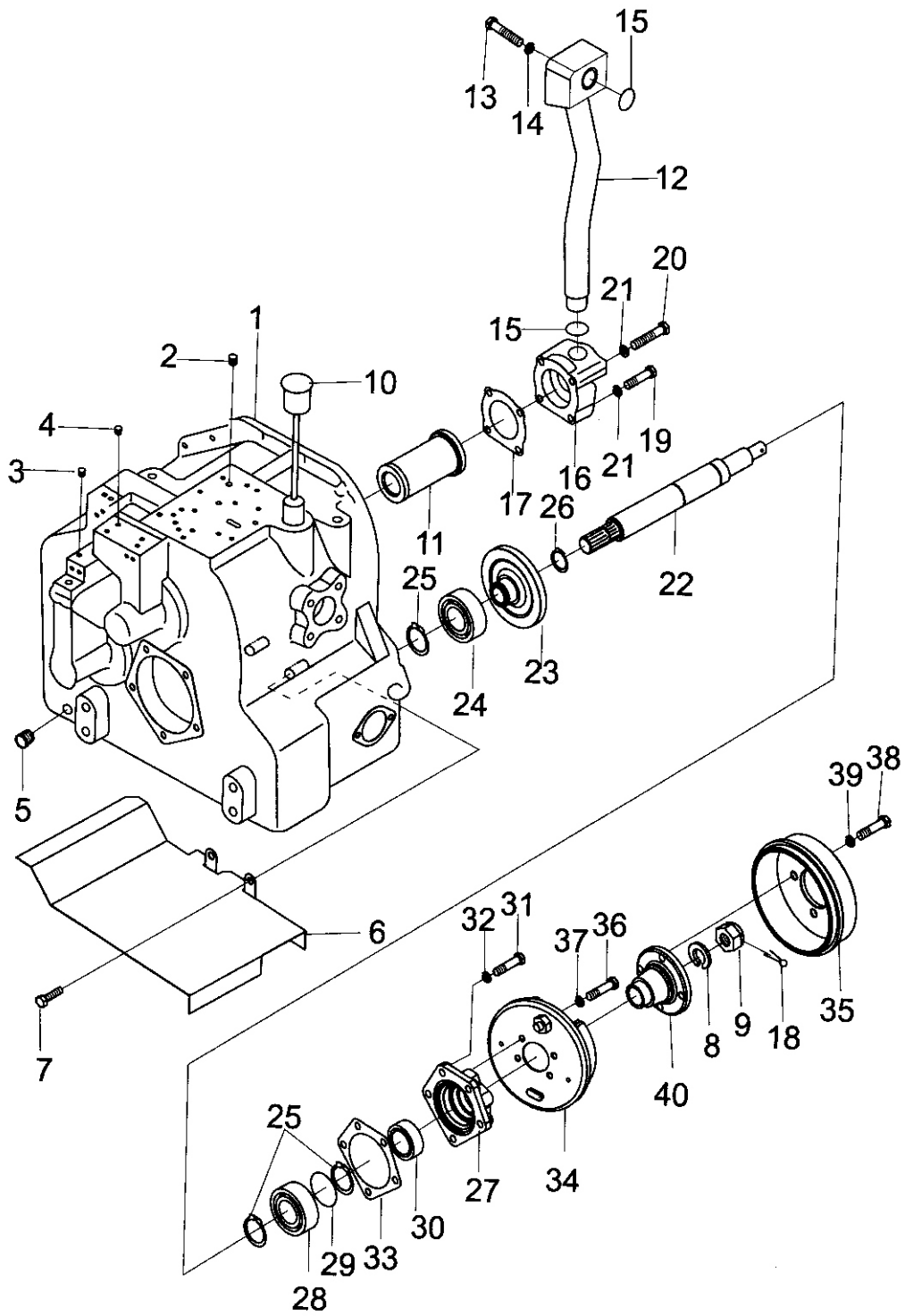

变速箱 (1/2)
Transmission (1/2)

序号 Item	零件号 Part No	零部件名称 Description	数量 Q'ty	备注 Remark
1	A50A5-00404	变速箱箱体 Case, transmission	1	
2	A50A5-00405	阻尼螺塞 Plug	1	
3	A50A5-00406	螺塞(1/8") Plug	14	
4	A50A5-00407	螺塞(3/8") Plug	2	
5	A50A5-00408	螺塞(3/4") Plug	2	
6	A50A5-00409	挡板 Plate, baffle	1	
7	GB/T5782	螺栓 M8×20 Bolt	2	
8	GB/T93	弹垫 Washer, lock	1	
9	GB/T9457	螺母 M20×1.5 Nut	1	
10	A50A5-00410	油标 Rod, lever	1	
11	A50A5-00411	滤油器 Strainer	1	
12	A50A5-00412	吸油管总成 Pipe oil fill	1	
13	GB/T5785	螺栓 M10×12.5×70 Bolt	2	
14	GB/T93	弹垫10 Washer, lock	2	
15	GB/T1235	O形圈 35×3.1 O-ring	2	
16	A50A5-00413	滤油器盖 Cover, filter	1	
17	A50A5-00414	垫 Gasket	1	
18	GB/T91	销4×36 Pin	1	
19	GB/T5785	螺栓 M10×12.5×50 Bolt	2	
20	GB/T5785	螺栓 M10×12.5×80 Bolt	2	
21	GB/T93	弹垫10 Washer, lock	4	
22	A50A5-00415	停车制动轴 Shaft, Parking	1	
23	A50A5-00416	停车制动齿轮 Gear	1	

变速箱 (1/2)
Transmission (1/2)

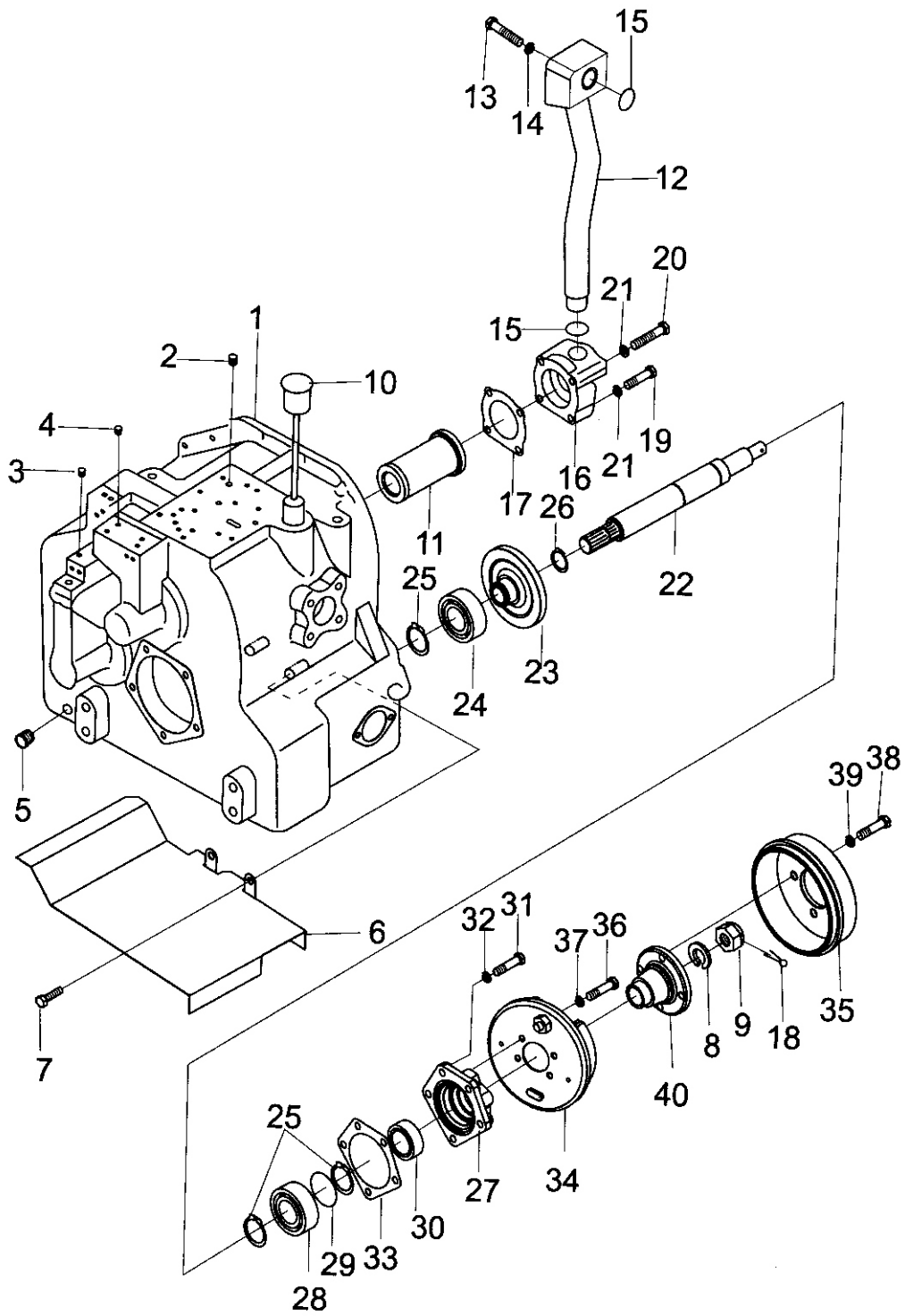

变速箱 (1/2)
Transmission (1/2)

序号 Item	零件号 Part No	零部件名称 Description	数量 Q'ty	备注 Remark
24	GB/T276	轴承208 Bearing	1	
25	GB/T894.1	挡圈40 Snap ring	3	
26	GB/T894.1	挡圈30 Snap ring	1	
27	A50A5-00417	端盖 Cap	1	
28	GB/T277	轴承50208 Bearing	1	
29	GB/T305	止动环80/86.6 Ring, thrust	1	
30	A50A5-00418	油封SG40×62×12 Oil seal	1	
31	GB/T5785	螺栓M10×1.25×30 Bolt	5	
32	GB/T93	弹垫10 Washer, lock	5	
33	A50A5-00419	垫 Gasket	1	
34	A50A5-00900	停车制动器总成 Brake ass'y	1	
35	A50A5-00420	制动鼓 Drum	1	
36	GB/T5785	螺栓M10×1.25×20 Bolt	4	
37	GB/T93	弹垫10 Washer, lock	4	
38	GB/T5785	螺栓M12×1.25×25 Bolt	4	
39	GB/T93	弹垫12 Washer, lock	4	
40	A50A5-00421	配合法兰 Flange	1	

变速箱 (2/2)
Transmission (2/2)

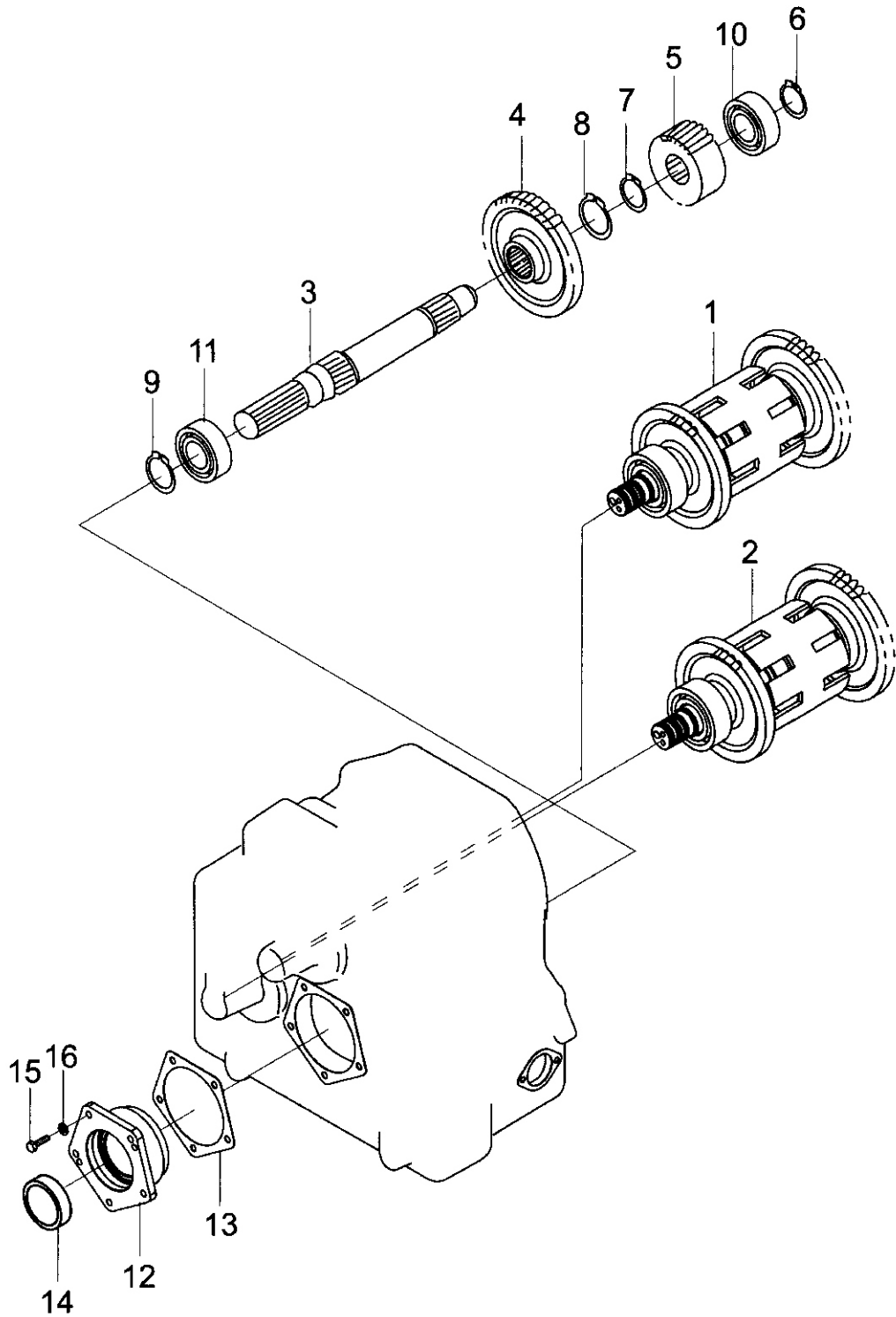

变速箱 (2/2)
Transmission (2/2)

序号 Item	零件号 Part No	零部件名称 Description	数量 Q'ty	备注 Remark
1	A50A5-01000	离合器 I Clutch	1	
2	A50A5-02000	离合器 II Clutch	1	
3	A50A5-00422	输出轴 Shaft, output	1	
4	A50A5-00423	齿轮 Gear	1	
5	A50A5-00424	齿轮 Gear	1	
6	GB/T894. 1	挡圈45 Snap ring	1	
7	GB/T894. 1	挡圈50 Snap ring	1	
8	GB/T894. 1	挡圈60 Snap ring	1	
9	GB/T894. 1	挡圈55 Snap ring	1	
10	GB/T276	轴承309 Bearing	1	
11	A50A5-00425	轴承 Bearing	1	
12	A50A5-00426	端盖 Cap	1	
13	A50A5-00427	垫片 Gasket	1	
14	A50A5-00428	油封52×72×12 Oil seal	5	
15	GB/T5785	螺栓M10×1.25×30 Bolt	5	
16	GB/T93	弹垫10 Washer, lock	1	

控制阀总成
Control valve ass'y

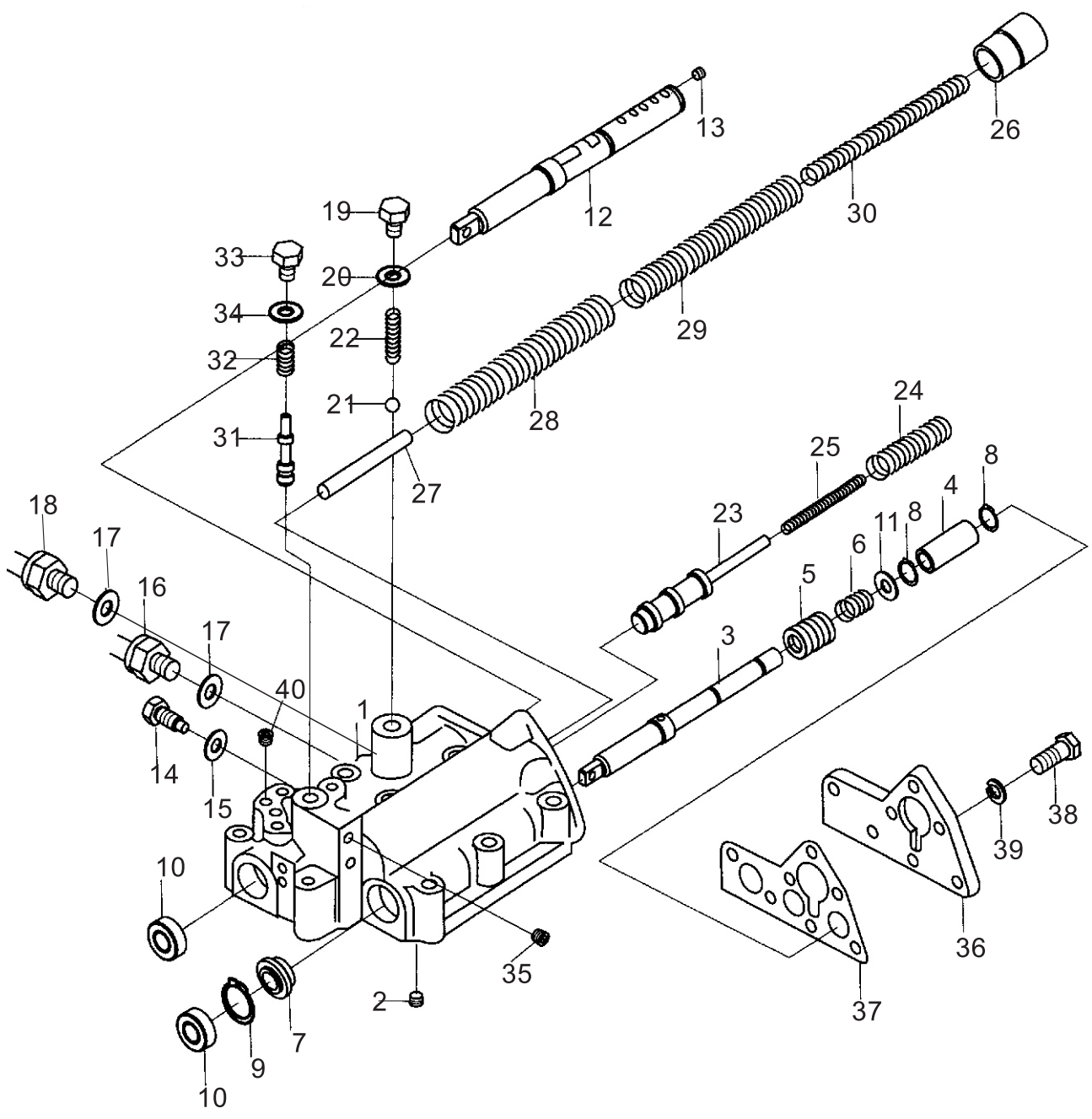

控制阀总成

Control valve ass'y

序号 Item	零件号 Part No	零部件名称 Description	数量 Q'ty	备注 Remark
A	A50A5-00600	控制阀总成 Control valve ass'y	1	
1	A50A5-00601	阀体 Body, valve	1	
2	A50A5-00602	阻尼螺塞 Plug	1	
3	A50A5-00603	微动阀杆 Valve, inching	1	
4	A50A5-00604	柱塞 Plunger	1	
5	A50A5-00605	活塞 Piston	1	
6	A50A5-00606	弹簧 Spring	1	
7	A50A5-00607	轴环 Collar	1	
8	GB/T894.1	挡圈12 Snap ring	2	
9	GB/T893.1	挡圈30 Snap ring	1	
10	A50A5-00608	油封 Oil seal	2	
11	A50A5-00609	挡环 Spacer	1	
12	A50A5-00610	操纵阀杆 Valve lever	1	
13	A50A5-00611	闷塞 Plug	1	
14	A50A5-00612	固定螺栓 Bolt	1	
15	A50A5-00613	垫圈 Washer	1	
16	DZ05G-J208	倒车灯开关 Switch	1	
17	DZ05G-J209	空档开关 Switch	1	
18	A50A5-00615	衬垫 Packing	2	
19	A50A5-00616	油塞 Plug	1	
20	A50A5-00617	垫圈 Washer	1	
21	GB/T308	钢球Φ10 Ball	1	
22	A50A5-00618	弹簧 Spring	1	
23	A50A5-00619	调节阀杆 Valve lever, modulate	1	
24	A50A5-00620	弹簧 Spring	1	

控制阀总成
Control valve ass'y

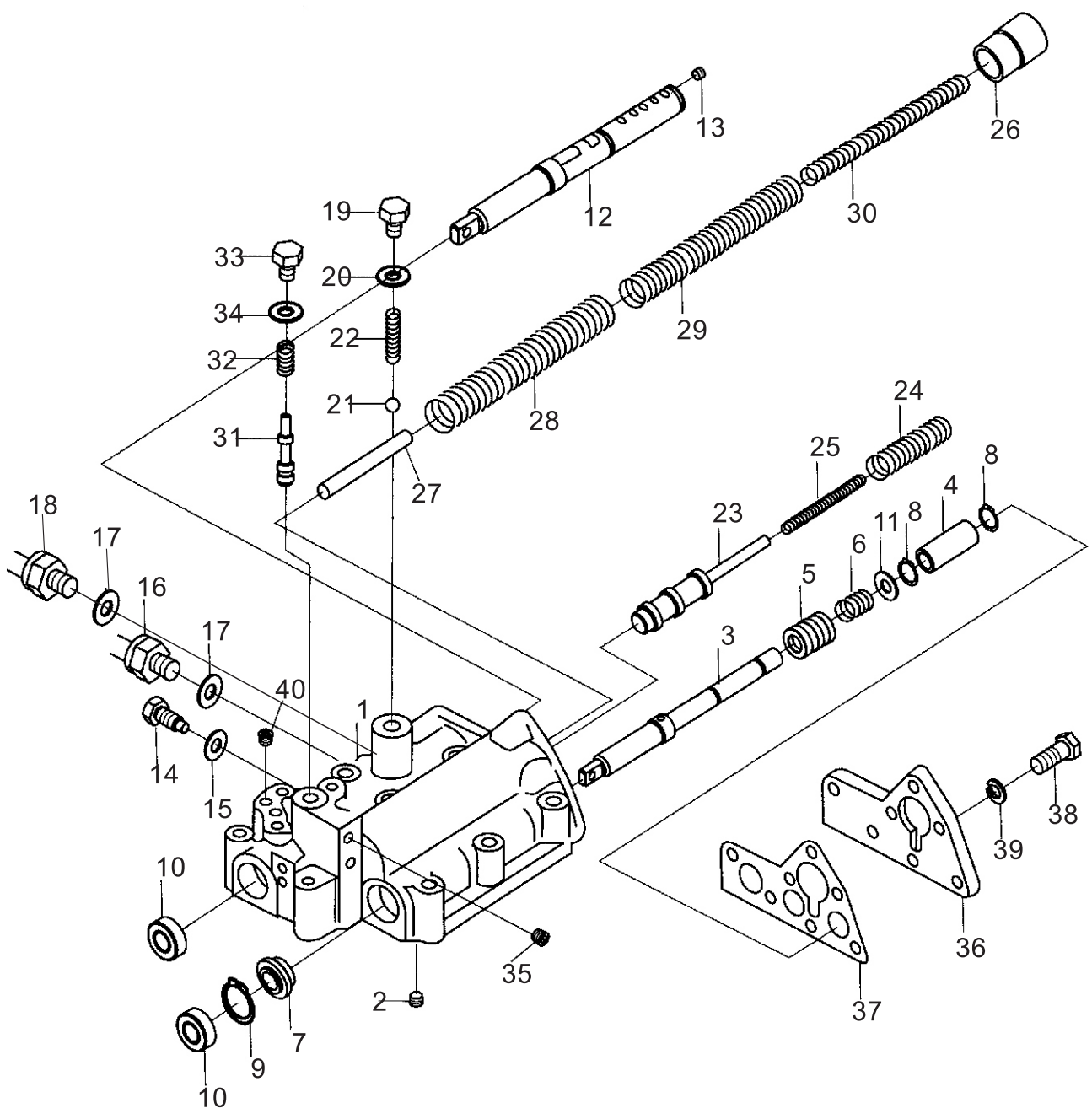

控制阀总成
Control valve ass'y

序号 Item	零件号 Part No	零部件名称 Description	数量 Q'ty	备注 Remark
25	A50A5-00621	弹簧 Spring	1	
26	A50A5-00622	活塞 Piston	1	
27	A50A5-00623	止动杆 Stopper	1	
28	A50A5-00624	弹簧 Spring	1	
29	A50A5-00625	弹簧 Spring	1	
30	A50A5-00626	弹簧 Spring	1	
31	A50A5-00627	测压阀杆 Valve lever	1	
32	A50A5-00628	弹簧 Spring	1	
33	A50A5-00629	油塞 Plug	1	
34	A50A5-00630	垫圈 Washer	1	
35	A50A5-00631	螺塞 Plug	4	
36	A50A5-00632	阀端盖 Cover	1	
37	A50A5-00633	端盖垫片 Gasket	1	
38	GB/T5783	螺栓M8×25 Bolt	7	
39	GB/T93	弹垫8 Washer, lock	7	
40	A50A5-00634	螺塞 Plug	5	

供油泵
Charging pump

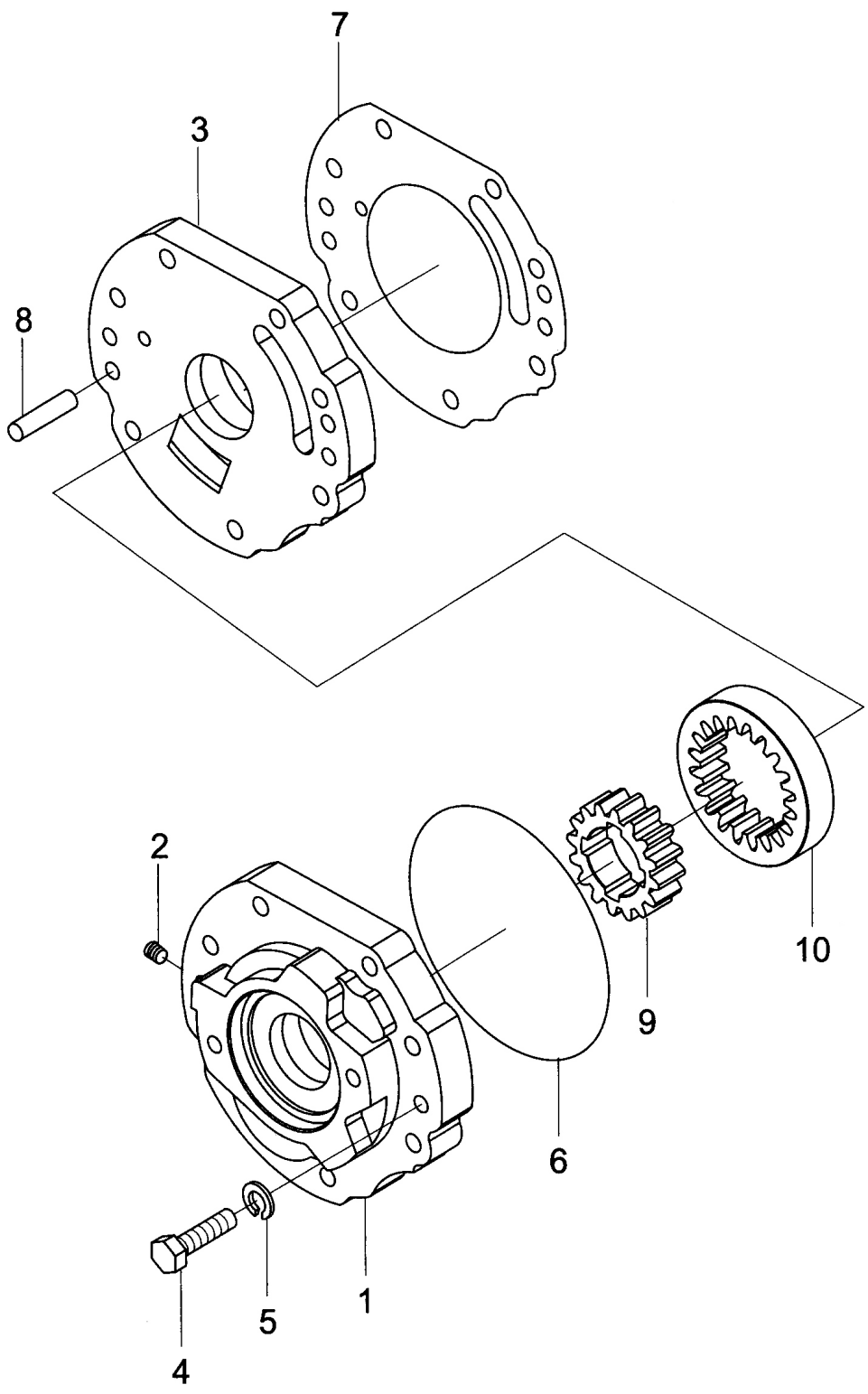

供油泵
Charging pump

序号 Item	零件号 Part No	零部件名称 Description	数量 Q'ty	备注 Remark
A	A50A5-03100	供油泵总成 Charging Pump ass'y	1	
1	A50A5-03101	泵体 Case, Pump	1	
2	A50A5-03102	螺塞 ZG1/8" Plug	1	
3	A50A5-03103	泵盖 Cover	1	
4	GB/T5785	螺栓M10×1.25×40 Bolt	2	
5	GB/T93	弹垫10 Washer, lock	2	
6	GB/T1235	O形圈 145×3.1 O-ring	1	
7	A50A5-03104	垫片 Shim	1	
8	GB/T119	销 B10×26 Pin	2	
9	A50A5-03105	泵齿轮 Gear	1	
10	A50A5-03106	供油泵齿圈 Gear, ring	1	

离合器 I
Hydraulic clutch I

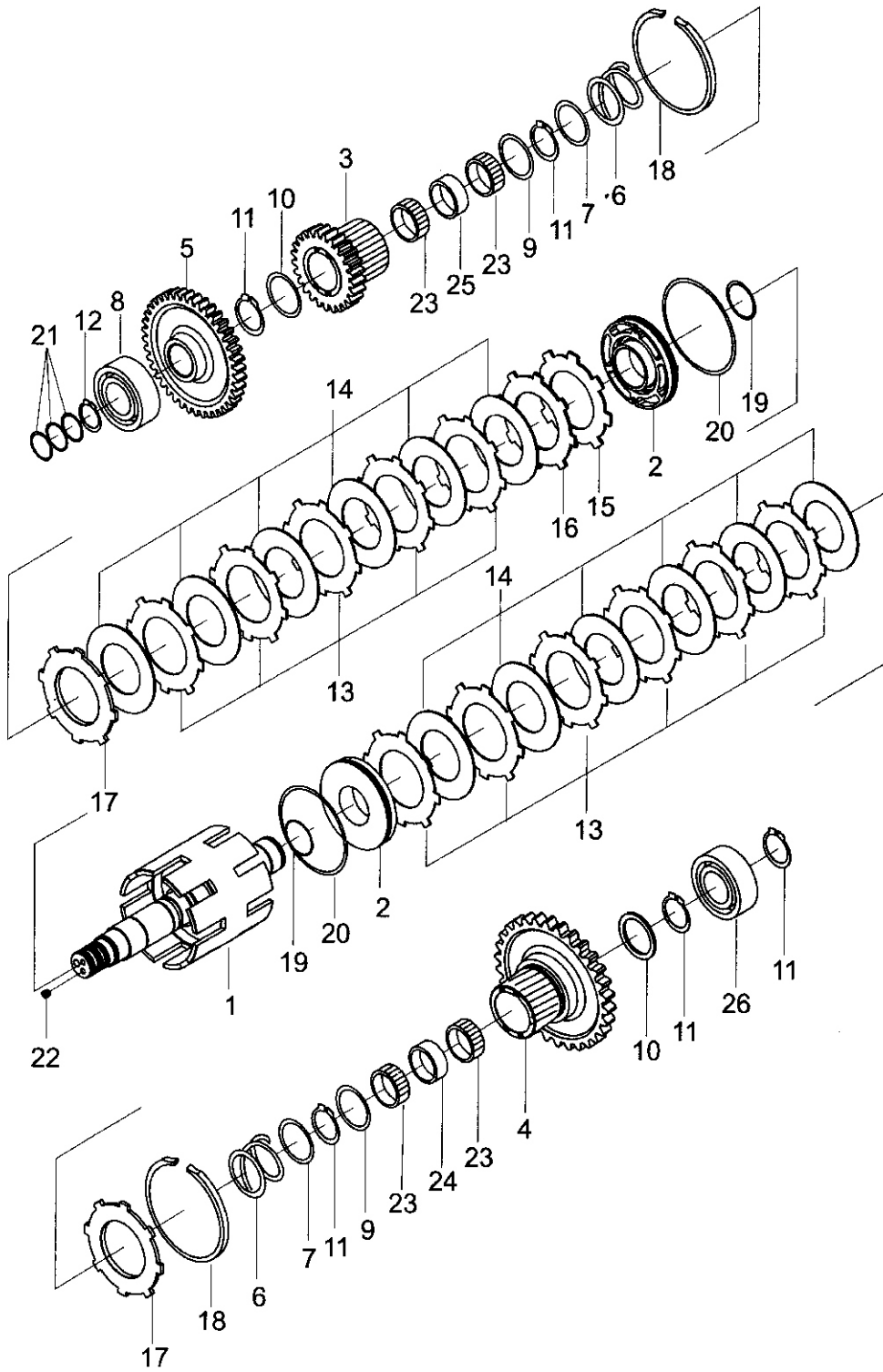

离合器 I

Hydraulic clutch I

序号 Item	零件号 Part No	零部件名称 Description	数量 Q'ty	备注 Remark
A	A50A5-01000	离合器 I Clutch	1	
1	A50A5-01100	轴总成 Shaft ass'y	1	
2	A50A5-01200	活塞总成 Piston ass'y	2	
3	A50A5-01001	齿轮 II Gear	1	
4	A50A5-01002	齿轮 I Gear	1	
5	A50A5-01003	齿轮 III Gear	1	
6	A50A5-01004	弹簧 Spring	2	
7	A50A5-01005	弹簧座 Seat, spring	2	
8	GB/T276	轴承6309 Bearing	1	
9	A50A5-01006	止推环 Ring, thrust	2	
10	A50A5-01007	止推环 Ring, thrust	2	
11	GB/T894. 1	挡圈50 Snap ring	5	
12	GB/T894. 1	挡圈45 Snap ring	1	
13	A50A5-01008	隔片 Plate, separator	13	
14	A50A5-01300	磨擦片总成 Plate, friction ass'y	14	
15	A50A5-01009	碟形板 Plate	1	
16	A50A5-01010	压板 Plate	1	
17	A50A5-01011	端板 Plate, end	2	
18	A50A5-01012	卡环 Snap ring	2	
19	A50A5-01013	密封环 Ring	2	
20	A50A5-01014	密封环 Ring	2	
21	A50A5-01015	密封环 Ring	3	
22	A50A5-01016	螺塞 Plug	2	
23	A50A5-01017	滚针轴承 Bearing	4	
24	A50A5-01018	隔圈 Spacer	1	
25	A50A5-01019	隔圈 Spacer	1	
26	GB/T276	轴承6210 Bearing	1	

离合器 II

Hydraulic clutch II

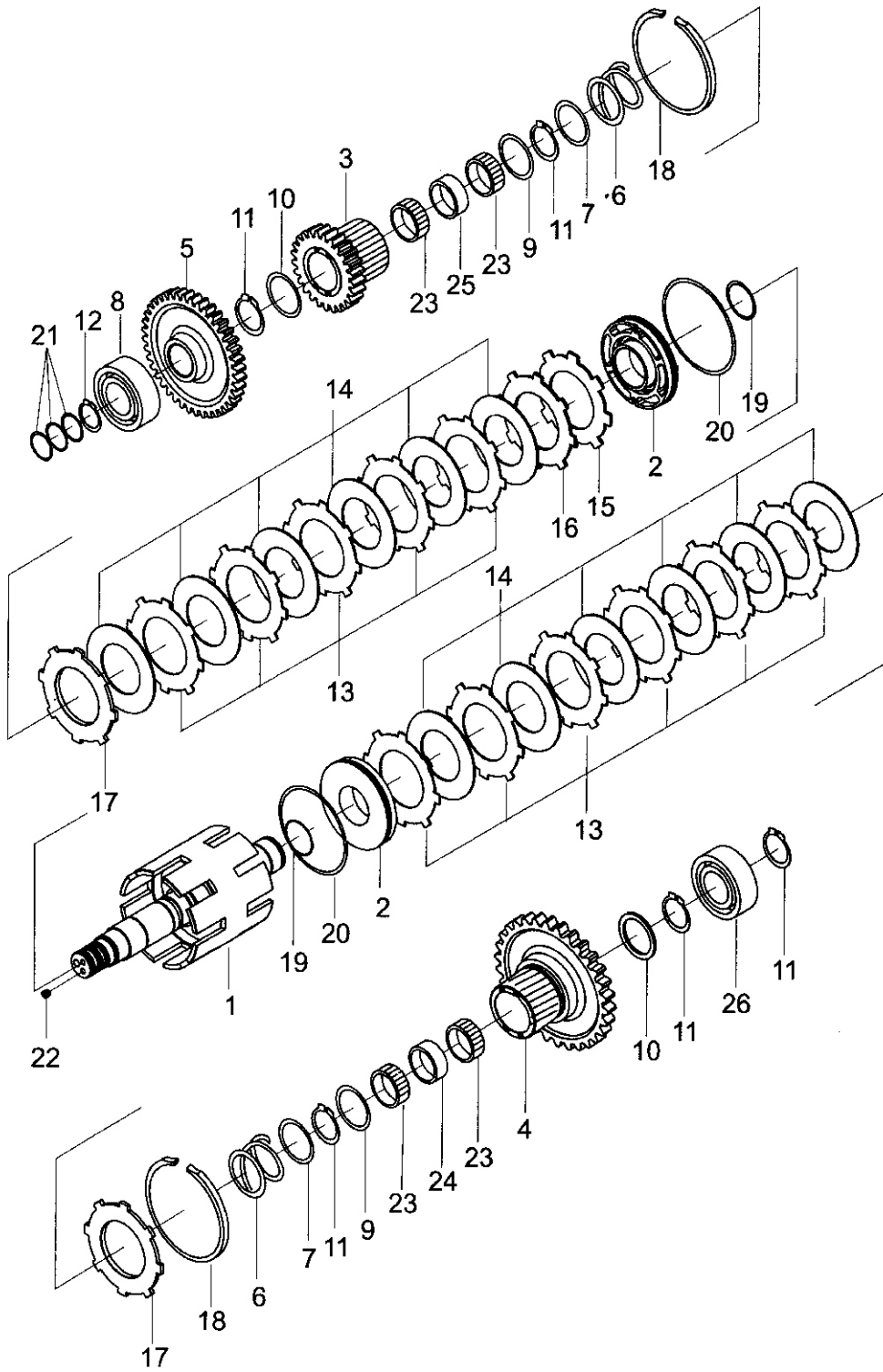

离合器 II

Hydraulic clutch II

序号 Item	零件号 Part No	零部件名称 Description	数量 Q'ty	备注 Remark
A	A50A5-02000	离合器 II Clutch	1	
1	A50A5-01100	轴总成 Shaft ass'y	1	
2	A50A5-01200	活塞总成 Piston ass'y	2	
3	A50A5-01001	齿轮 II Gear	1	
4	A50A5-02001	齿轮 IV Gear	1	
5	A50A5-01003	齿轮 III Gear	1	
6	A50A5-01004	弹簧 Spring	2	
7	A50A5-01005	弹簧座 Seat, spring	2	
8	GB/T276	轴承 6309 Bearing	1	
9	A50A5-01006	止推环 Ring, thrust	2	
10	A50A5-01007	止推环 Ring, thrust	2	
11	GB/T894. 1	挡圈 50 Snap ring	5	
12	GB/T894. 1	挡圈 45 Snap ring	1	
13	A50A5-01008	隔片 Plate, separator	13	
14	A50A5-01300	磨擦片总成 Plate, friction ass'y	14	
15	A50A5-01009	碟形板 Plate	1	
16	A50A5-01010	压板 Plate	1	
17	A50A5-01011	端板 Plate, end	2	
18	A50A5-01012	卡环 Snap ring	2	
19	A50A5-01013	密封环 Ring	2	
20	A50A5-01014	密封环 Ring	2	
21	A50A5-01015	密封环 Ring	2	
22	A50A5-01016	螺塞 Plug	2	
23	A50A5-01017	滚针轴承 Bearing	4	
24	A50A5-01018	隔圈 Spacer	1	
25	A50A5-01019	隔圈 Spacer	1	
26	GB/T276	轴承 6210 Bearing	1	

停车制动器总成
Parking brake ass'y

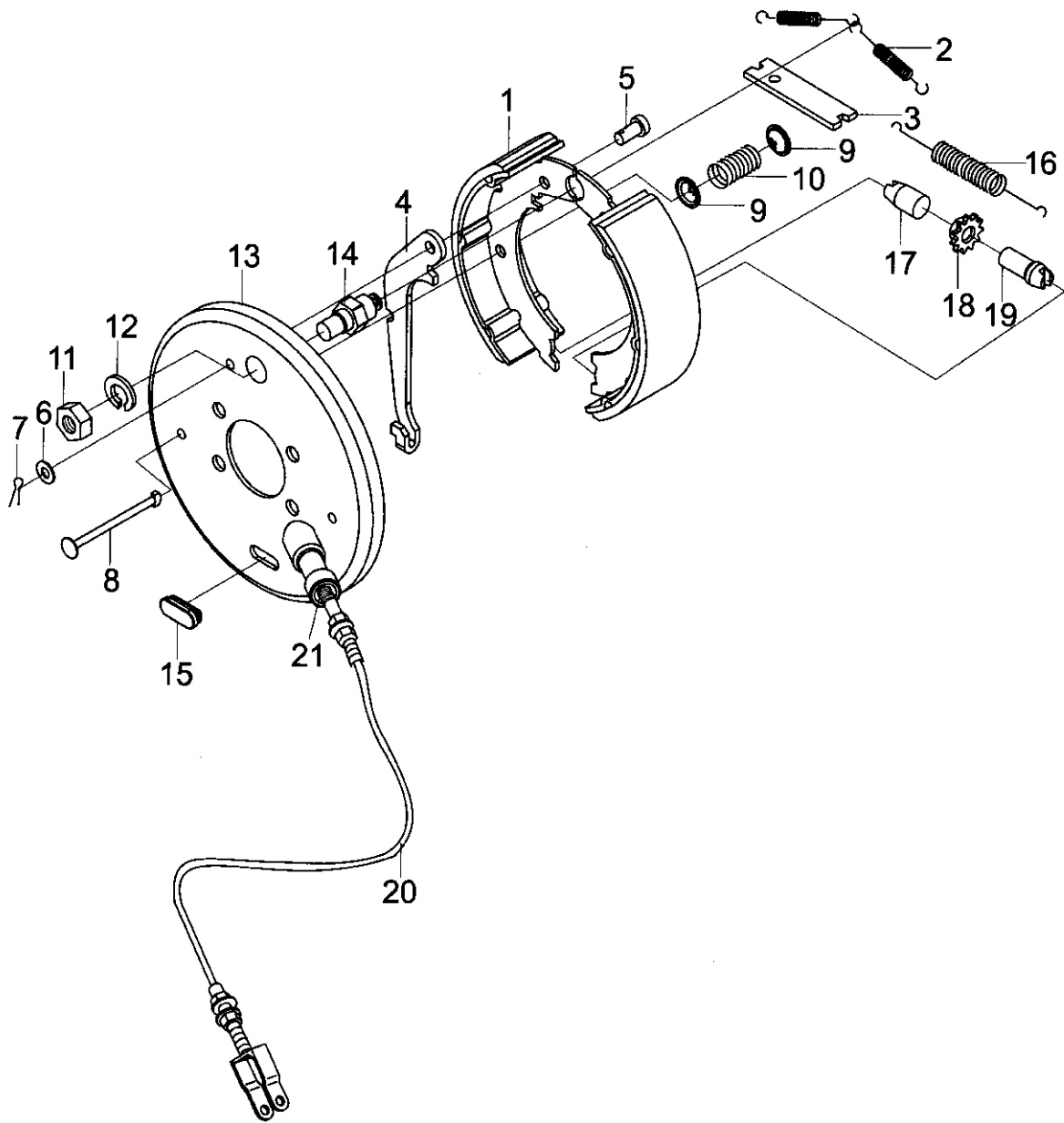

停车制动器总成 Parking brake ass'y

序号 Item	零件号 Part No	零部件名称 Description	数量 Q'ty	备注 Remark
A	A50A5-00900	停车制动器总成 Parking brake ass'y	1	
1	A50A5-00901	手制动蹄带磨擦片总成 Brake shoe & lining	2	
2	A50A5-00902	手制动蹄回位弹簧 Sping	2	
3	A50A5-00903	手制动蹄推板 Board	1	
4	A50A5-00904	手制动蹄拉臂 Lever brake	1	
5	GB/T882	销B8×16 Pin	1	
6	GB/T97.1	平垫 Washer	1	
7	GB/T91	销3×20 Pin	1	
8	A50A5-00905	手制动蹄定位销 Pin	1	
9	A50A5-00906	手制动蹄定位弹簧座 Cup, shoe hold down	1	
10	A50A5-00907	手制动蹄定位弹簧 Spring	1	
11	GB/T6171	螺母M8 Nut	1	
12	GB/T93	弹垫8 Washer, lock	1	
13	A50A5-00908	手制动底板总成 Back plate ass'y	1	
14	A50A5-00909	手制动蹄支轴 Pin	1	
15	A50A5-00910	手制动器底板调整孔堵塞 Plug	1	
16	A50A5-00911	手制动器蹄下端拉簧 Sping	1	
17	A50A5-00912	手制动器间隙调整套 Adjuster cover	1	
18	A50A5-00913	手制动间隙调整轮 Adjuster wheel	1	
19	A50A5-00914	手制动间隙调整螺钉 Adjuster screw	1	
20	A50A5-00915	制动拉索总成 Cable ass'y	1	
21	A50A5-00916	手制动器钢丝绳回位弹簧 Spring	1	

驱动桥
Drive axle

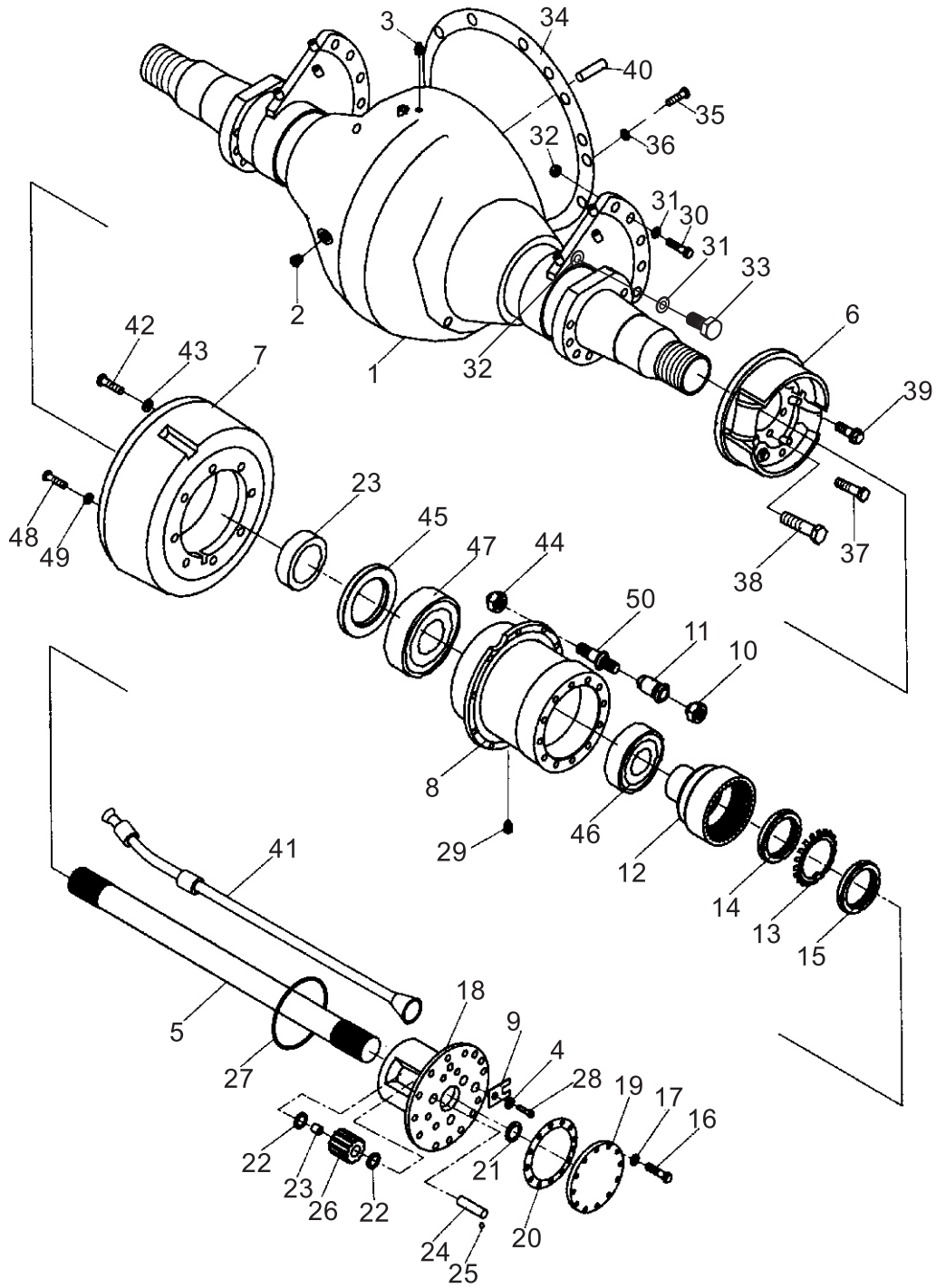

驱动桥 Drive axle

序号 Item	零件号 Part No	零部件名称 Description	数量 Q'ty	备注 Remark
1	A50A5-00200	驱动桥总成 Housing axle	1	FD50,60,70,80-CY1/W3
-	A50E5-00200	驱动桥总成 Housing axle	1	FD50,60,70,80-S3/YC2 FY50,60,70,80-G3/G4
-	A50K5-00100	驱动桥总成 Housing axle	1	FD50,60,70,80-KMS2
2	A50A5-00201	桥壳螺塞 Plug, drain	2	
3	A50A5-00202	透气塞总成 Breather	1	
4	GB/T97.1	平垫10 Washer	2	
5	A50A5-00203	半轴 Shaft, axle	2	
6	A50A5-04000	制动器总成 Wheel brake ass'y	2	FD50,60,70,80-CY1/W3
-	A50E5-00500	制动器总成 Wheel brake ass'y	2	FD50,60,70,80-S3/YC2 FY50,60,70,80-G3/G4
-	A50K5-00200	制动器总成 Wheel brake ass'y	2	FD50,60,70,80-KMS2
7	A50A5-00204	制动鼓 Drum	2	
8	A50A5-00205	轮毂 Hub	2	
9	A50A5-00004	固定板 Plate	2	
10	A50A5-00207	外螺母 Nut, hub outer	20	
11	A50A5-00208	内螺母 Nut, hub inner	20	
12	A50A5-00209	内齿圈 Gear, internal	2	
13	A50A5-00210	防松垫圈 Washer, lock	2	
14	A50A5-00211	锁紧螺母(内)M75×2 Nut spindle inner	2	
15	A50A5-00212	锁紧螺母(外)M75×2 Nut spindle inner	2	
16	GB/T5786	螺栓M12×1.25×25 Bolt	12	
17	GB/T93	弹垫12 Washer	12	
18	A50A5-00213	行星齿轮支架 Carrier, planet	2	
19	A50A5-00214	半轴端盖 Cap, axle shaft	2	
20	A50A5-00215	端盖纸垫 Washer	2	
21	A50A5-00216	止推垫块 Washer, thrust	2	
22	A50A5-00217	止推垫片 Washer, thrust	12	
23	A50A5-00218	轴套 Bushing	6	

驱动桥
Drive axle

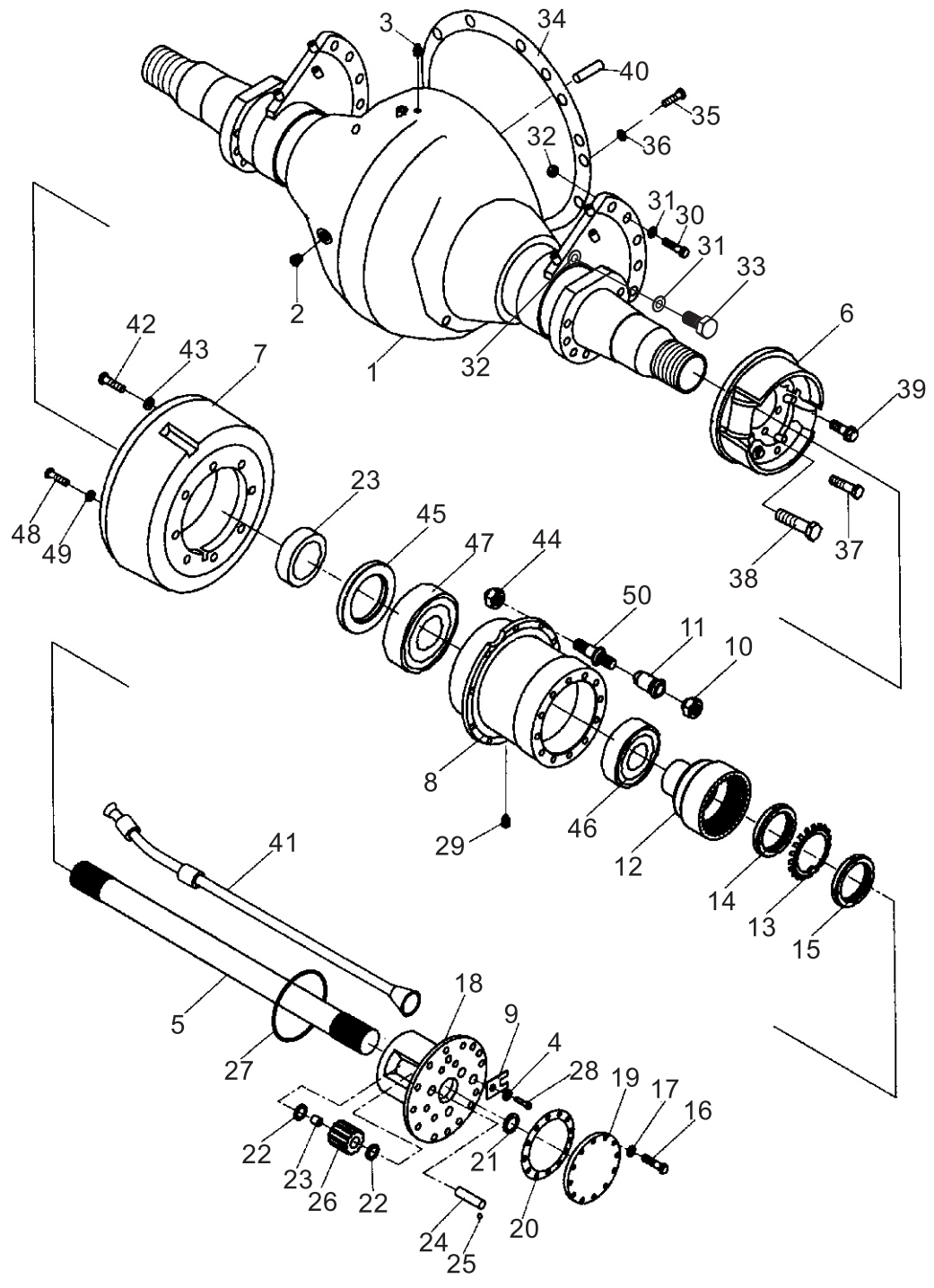

驱动桥
Drive axle

序号 Item	零件号 Part No	零部件名称 Description	数量 Q'ty	备注 Remark
24	A50A5-00219	行星齿轮轴 Shaft, planet gear	6	
25	GB/T308	钢球 $\phi 6$ Ball	6	
26	A50A5-00220	行星齿轮 Gear, planet	6	
27	A50A5-00221	O形密封圈 O-ring	2	
28	A50A5-00222	螺栓 Bolt	32	
29	A50A5-00223	堵塞 Plug	2	
30	A50A5-00005	螺栓 Bolt	6	
31	GB/T93	弹垫 Washer	10	
32	GB/T6171	螺母M24 \times 2 Nut	10	
33	A50A5-00003	铰制螺栓 Bolt, reamer	4	
34	A50A5-00225	纸垫 Packing	1	
35	GB/T5786	螺栓M14 \times 1.5 \times 40 Bolt	14	
36	GB/T93	弹垫14 Washer, lock	14	
37	A50A5-00226	螺栓 Bolt	12	
38	A50A5-00227	螺栓 Bolt	4	
39	A50A5-00228	螺栓 Bolt	4	
40	GB/T119.1	销B12 \times 26 Pin	2	
41	A50A5-00700	充气接管 Pipe	2	
42	A50A5-00230	铰制螺栓 Bolt, reamer	4	
43	A50A5-00231	平垫圈 Washer	4	
44	GB/T6171	螺母M20 \times 1.5 Nut	20	
45	A50A5-00232	油封AD4399A0 Seal, oil	4	
46	GB/T297	轴承33020 Bearing, taper roller	2	
47	A50A5-00233	大轴承 Bearing, taper roller	2	
48	A50A5-00234	螺栓 Bolt	12	
49	A50A5-00235	锥形垫圈 Washer, conical spring	12	
50	A50A5-00236	螺栓柱 Bolt, hub	20	

驱动轮总成
Driving wheel assembly

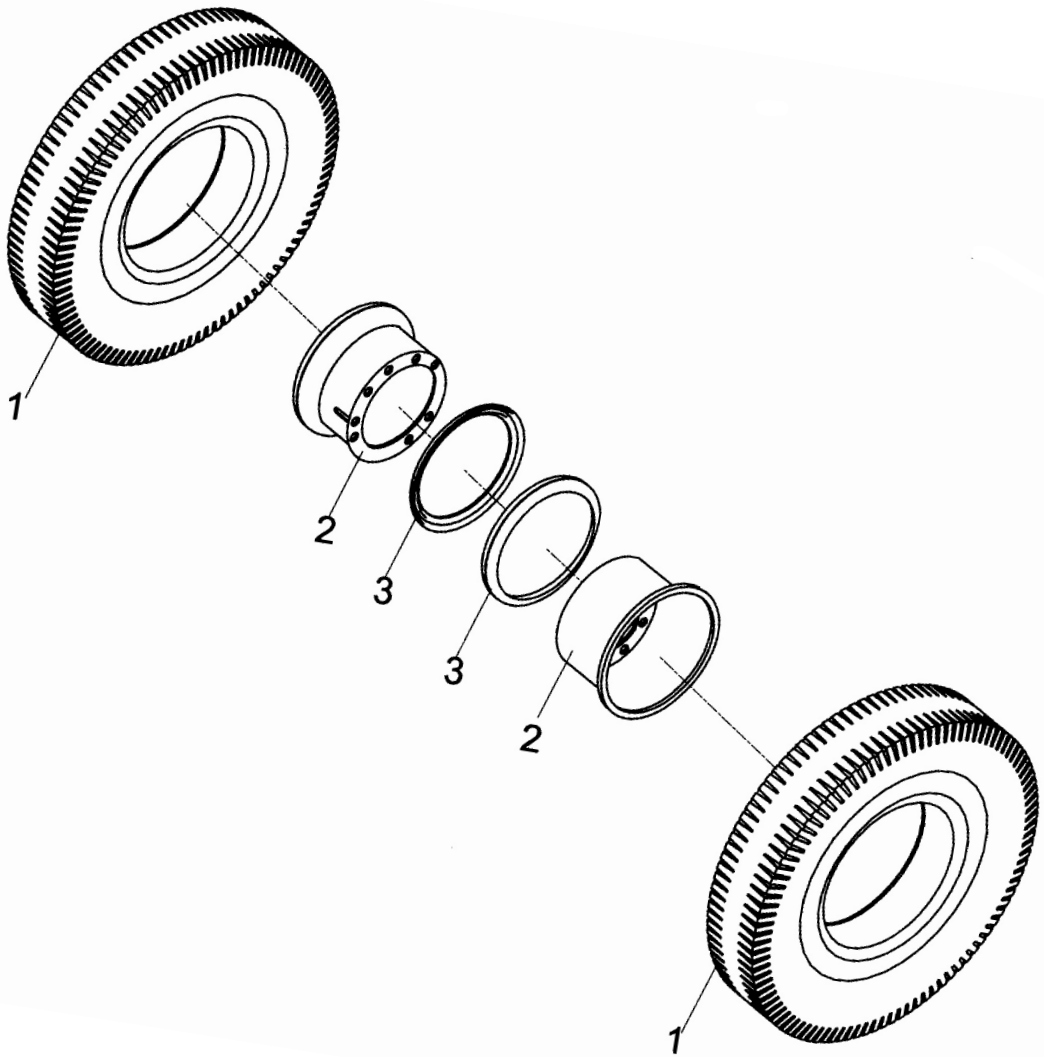

驱动轮总成
Driving wheel assembly

序号 Item	零件号 Part No	零部件名称 Description	数量 Q'ty	备注 Remark
A	A50A5-00100	轮辋总成(包含2,3) Rim ass'y(Inc.2,3)	4	
1	GB/T2982	轮胎8.25-15-14PR Tyre	4	
2	A50A5-00101	轮辋 Rim	4	
3	A50A5-00102	挡圈 Snap,ring	4	

轮式制动器
Wheel brake

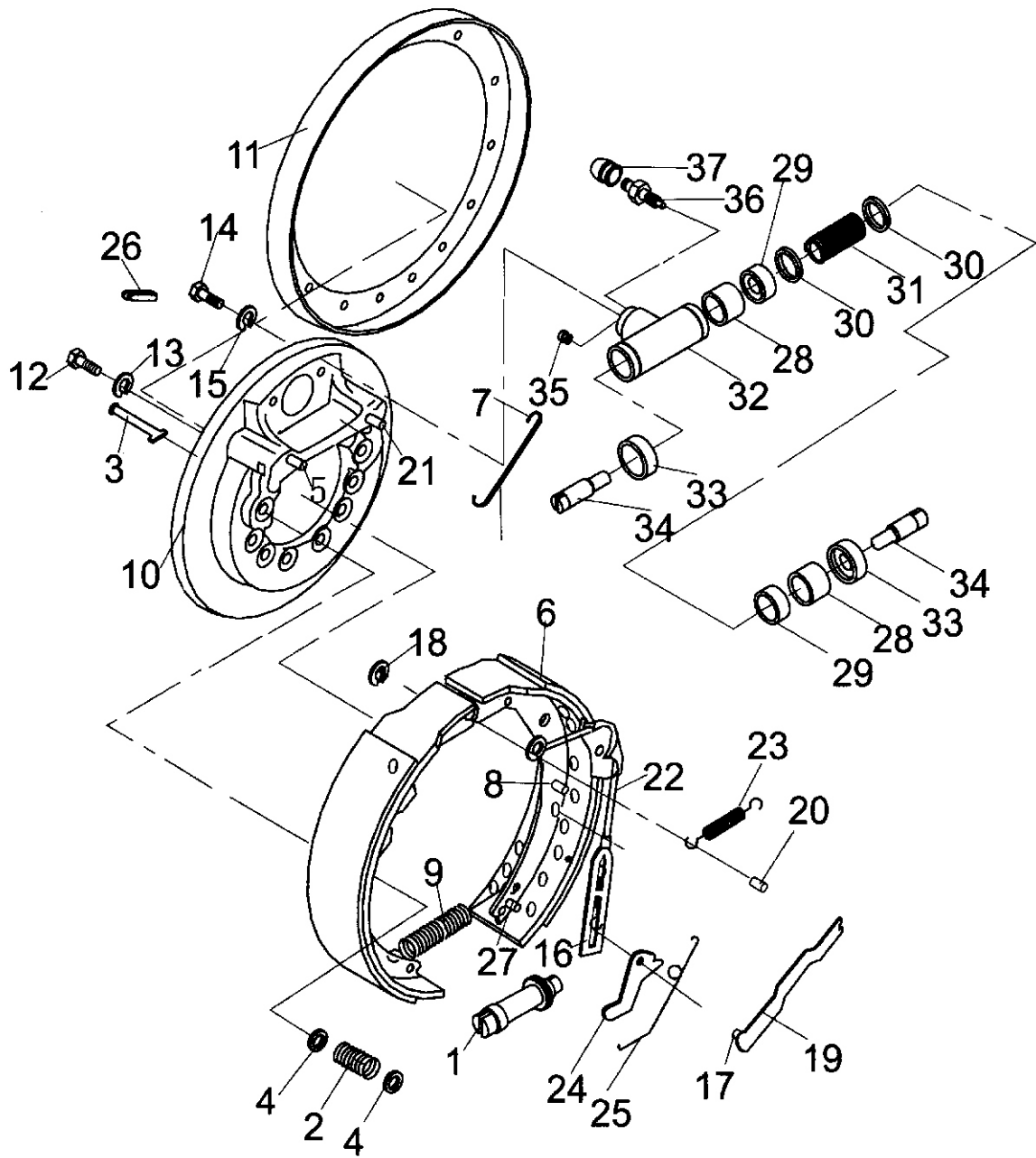

轮式制动器 Wheel brake

序号 Item	零件号 Part No	零部件名称 Description	数量 Q'ty	备注 Remark
A	A50A5-04000(L)	制动器总成 (左) Wheel brake	1	FD50,60,70,80-CY1/W3
-	A50E5-00500(L)	制动器总成 (左) Wheel brake	1	FD50,60,70,80-S3/YC2 FY50,60,70,80-G3/G4
-	A50K5-00200(L)	制动器总成 (左) Wheel brake	1	FD50,60,70,80-KMS2
-	A50A5-04000(R)	制动器总成 (右) Wheel brake	1	FD50,60,70,80-CY1/W3
-	A50E5-00500(R)	制动器总成 (右) Wheel brake	1	FD50,60,70,80-S3/YC2 FY50,60,70,80-G3/G4
-	A50K5-00200(R)	制动器总成 (右) Wheel brake	1	FD50,60,70,80-KMS2
1	A50A5-04001	调整器总成 Adjuster ass'y	1	
2	A50A5-04002	弹簧F Spring	2	
3	A50A5-04003	压簧拉杆 Pin,shoe hold down	2	
4	A50A5-04004	压簧座 Cup,shoe hold down	4	
5	A50A5-04005	销 Pin	2	
6	A50A5-04006	制动蹄带磨擦片总成 Shoe pin & lining ass'y	2	
7	A50A5-04007	弹簧E Spring	1	
8	A50A5-04008	销 Pin	1	
9	A50A5-04009	弹簧B Spring	1	
10	A50A5-04010	制动器底板 Backboard,brake	1	
11	A50A5-04011	罩壳 Sheald dust	1	
12	A50A5-04012	螺栓 Bolt	6	
13	GB/T93	弹垫6 Washer,lock	6	
14	GB/T5782	螺栓M8×45 Bolt	2	
15	GB/T93	弹垫6 Washer.lock	2	
16	A50A5-04013	弹簧铆接装置 Spring joint unit	1	
17	GB/T91	销1.6×16 Pin	1	
18	A50A5-04014	垫圈 Washer	1	
19	A50A5-04015	摇臂 Link	1	

轮式制动器
Wheel brake

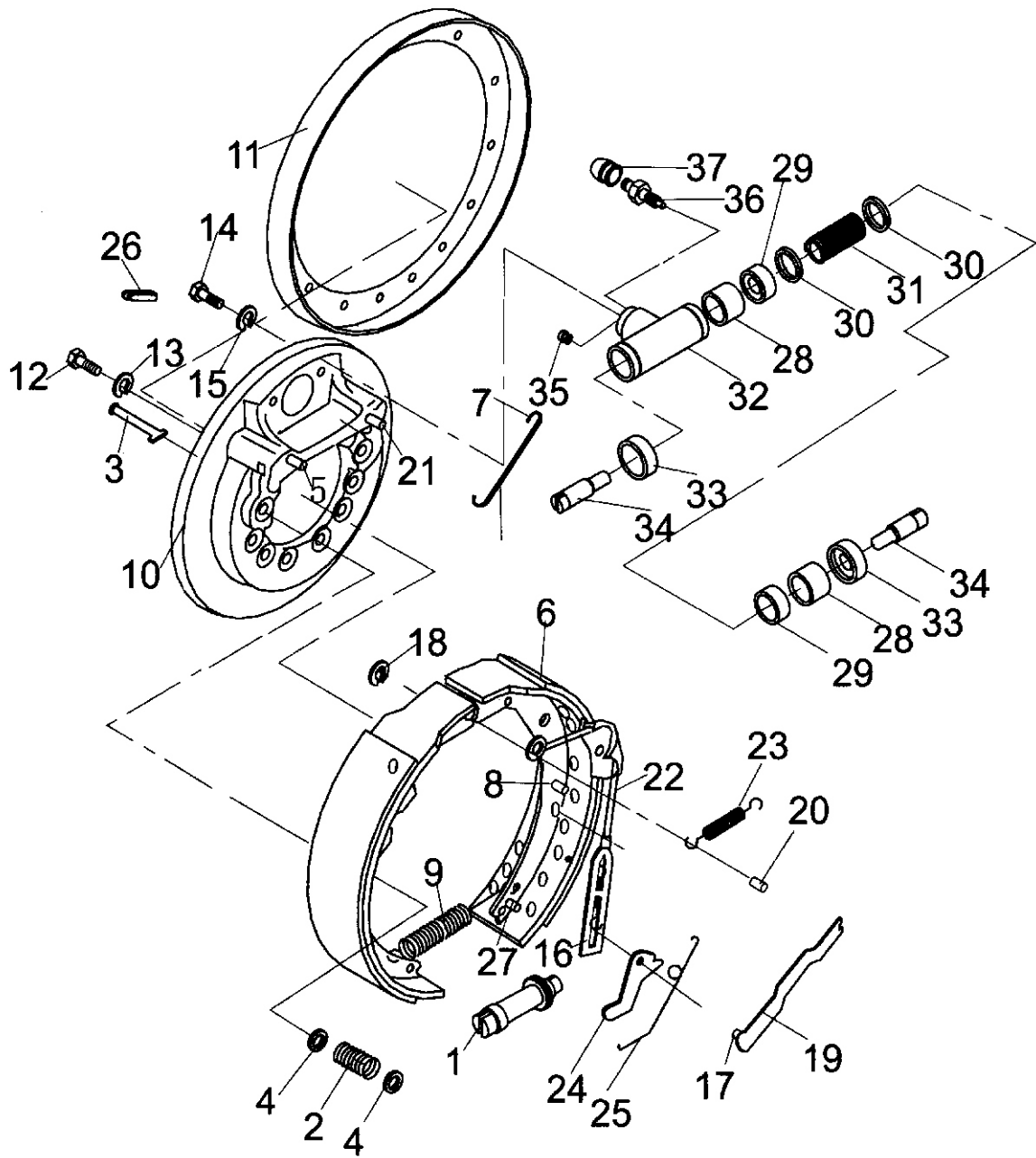

轮式制动器 Wheel brake

序号 Item	零件号 Part No	零部件名称 Description	数量 Q'ty	备注 Remark
20	A50A5-04016	销 Pin	1	
21	A50A5-04017	销 Pin	1	
22	A50A5-04018	上拉杆 Lever	1	
23	A50A5-04019	弹簧A Spring	1	
24	A50A5-04020	棘爪 Lever	1	
25	A50A5-04021	弹簧G Spring	1	
26	A50A5-04022	堵塞 Cover.adjusting hole	1	
27	A50A5-04023	销 Pin	1	
B	A50A5-05000	制动分泵总成 Wheel cylinder ass'y	1	FD50,60,70,80-CY1/W3
-	A50E5-00600	制动分泵总成 Wheel cylinder ass'y	1	FD50,60,70,80-S3/YC2 FY50,60,70,80-G3/G4
-	A50K5-00300	制动分泵总成 Wheel cylinder ass'y	1	FD50,60,70,80-KMS2
28	A50A5-05001	分泵活塞 Piston	2	
29	A50A5-05002	密封垫 Sealing washer	2	FD50,60,70,80-CY1/W3
-	A50E5-00601	密封垫 Sealing washer	2	FD50,60,70,80-S3/YC2 FY50,60,70,80-G3/G4
-	A50K5-00301	密封垫 Sealing washer	2	FD50,60,70,80-KMS2
30	A50A5-05003	分泵皮碗 Cup, piston	2	FD50,60,70,80-CY1/W3
-	A50E5-00602	分泵皮碗 Cup, piston	2	FD50,60,70,80-S3/YC2 FY50,60,70,80-G3/G4
-	A50K5-00302	分泵皮碗 Cup, piston	2	FD50,60,70,80-KMS2
31	A50A5-05004	分泵弹簧 Spring	1	
32	A50A5-05005	制动分泵缸 Cylinder	1	
33	A50A5-05006	分泵护罩 Cover, dust	2	
34	A50A5-05007	分泵活塞顶杆 Rod, piston	2	
35	A50A5-05008	制动分泵油塞 Plug	1	
36	A50A5-05009	分泵放气螺钉 Screw, breather	1	
37	A50A5-05010	分泵放气螺钉帽 Cap, screw	1	

变速箱变速操纵 Transmission control linkage

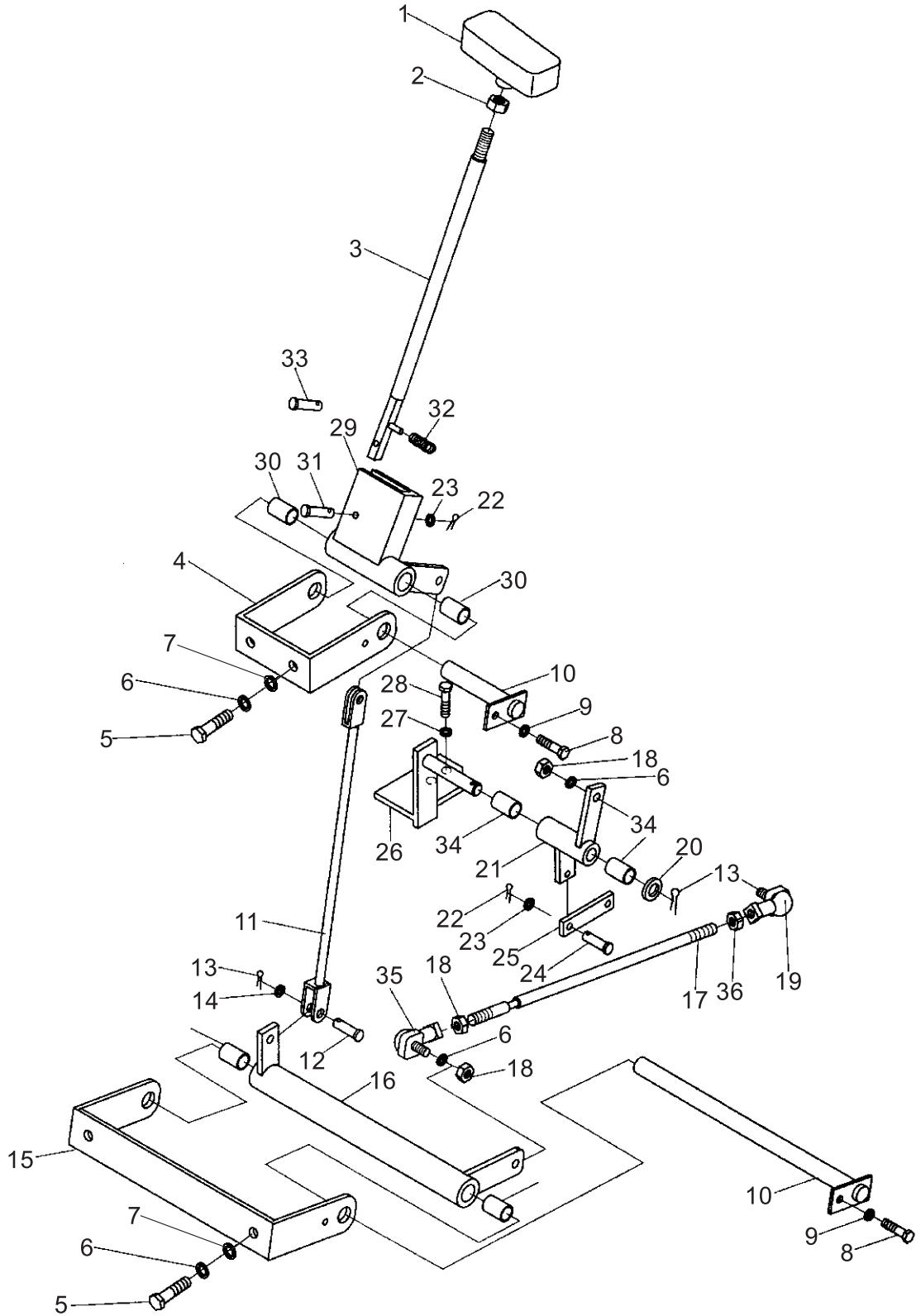

变速箱变速操纵 Transmission control linkage

序号 Item	零件号 Part No	零部件名称 Description	数量 Q'ty	备注 Remark
A	A50A5-06000	变速操纵 Transmission control linkage	1	
1	A50A5-06001	手柄 Knob	1	
2	GB/T6171	螺母M10 Nut	1	
3	A50A5-06002	操纵杆 Lever	1	
4	A50A5-06003	支架(上) Bracket(upper)	1	
5	GB/T5783	螺栓M8×35 Bolt	4	
6	GB/T93	弹垫8 Washer,lock	6	
7	GB/T97.1	平垫8 Washer	4	
8	GB/T5783	螺栓M6×12 Bolt	2	
9	GB/T93	弹垫6 Washer,lock	2	
10	A50A5-06004	销轴总成 Shaft	1	
11	A50A5-06005	连杆 Link	1	
12	G/TB882	销B8×18 Pin,clevis	2	
13	GB/T91	销3.2×26 Pin,cotter	3	
14	GB/T97.1	平垫8 Washer	3	
15	A50A5-06006	支架(下) Bracket(lower)	1	
16	A50A5-06007	联轴 Boss	1	
17	A50A5-06008	连杆 Link	1	
18	GB/T6171	螺母M8 Nut	3	
19	A50A5-06009	弯杆型球头杆端关节轴承 Bearing	1	
20	GB/T97.1	平垫10 Washer	1	
21	A50A5-06010	摇臂 Boss	1	
22	GB/T91	销1.6×10 Pin,cotter	3	

变速箱变速操纵 Transmission control linkage

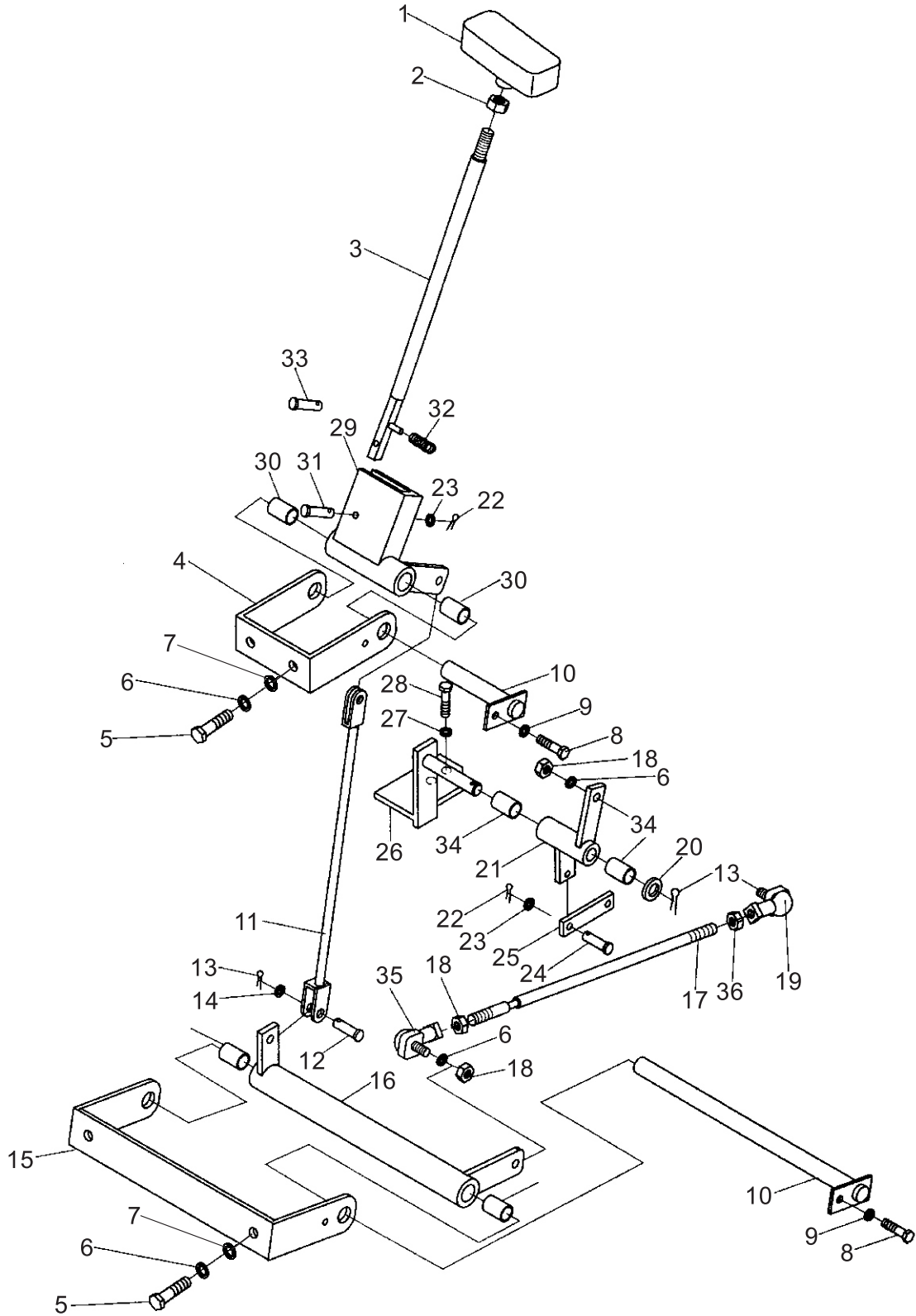

变速箱变速操纵
Transmission control linkage

序号 Item	零件号 Part No	零部件名称 Description	数量 Q'ty	备注 Remark
23	GB/T97.1	平垫6 Washer	2	
24	GB/T882	销B6×26 Pin	1	
25	A50A5-06011	连杆 Link	2	
26	A50A5-06012	支架 Bracket	1	
27	GB/T93	弹垫10 Washer,lock	5	
28	GB/T5786	螺栓M10×1.25×20 Bolt	2	
29	A50A5-06013	联轴 Boss	1	
30	A50A5-06014	钢背轴承16×25 Bushing	4	
31	GB/T882	销B6×35 Pin,clevis	1	
32	A50A5-06015	弹簧 Spring	1	
33	A50A5-06016	销轴总成 Pin,clevis	1	
34	A50A5-06017	钢背轴承1215 Bushing	2	
35	A50A5-06018	弯杆型球头杆端关节轴承 Bearing	1	
36	GB/T6170	螺母（左）M8 Nut	1	

三、转向系统

STEERING SYSTEM

转向操纵 Steering control

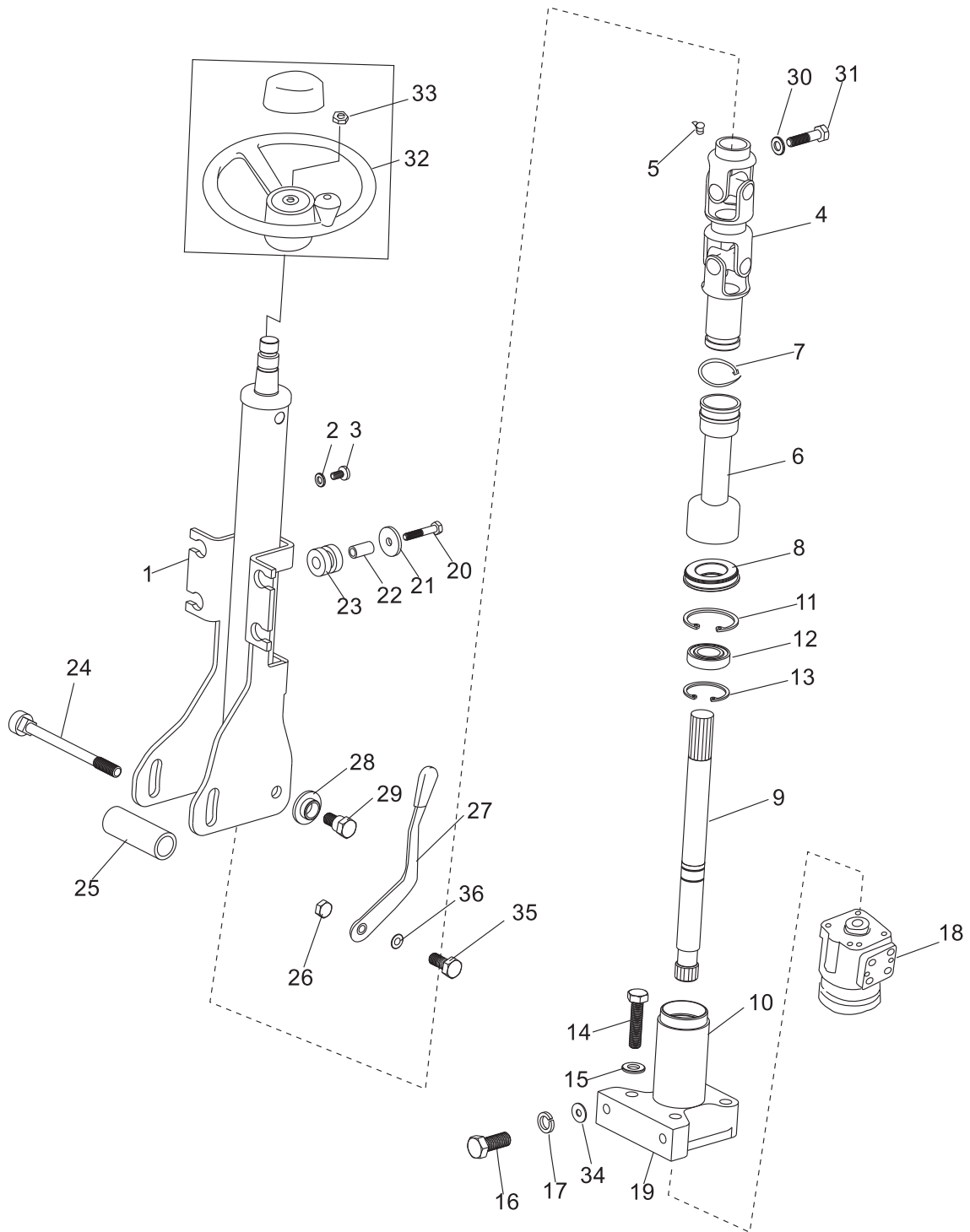

转向操纵 Steering control

序号 Item	零件号 Part No	零部件名称 Description	数量 Q'ty	备注 Remark
1	A50A6-00100	转向管柱总成 Steering column	1	
2	GB/T97.1	平垫 6 Washer	4	
3	GB/T818	螺钉 M6×12 Screw	4	
4	A50A6-00200	万向节总成 Joint	1	
5	JB/T7940.1	油杯M10×1 Cup,grease	1	
6	A30C6-00003	护套 Boot	1	
7		捆扎带ZD4×150 Band	1	
8	A30C6-00004	密封盖 Seal cover	1	
9	A30C6-00301	连接轴 Link	1	
10	A30C6-00302	连接法兰 Flange	1	
11	GB/T893.1	弹性挡圈37 Snap ring	1	
12	GB/T276	轴承61904-2Z Bearing	1	
13	GB/T894.1	弹性挡圈20 Snap ring	2	
14	GB/T5783	螺栓M10×45 Bolt	4	
15	GB/T93	弹垫 10 Washer,lock	4	
16	GB/T5786	螺栓M12×1.25×20 Bolt	2	
17	GB/T93	弹垫 12 Washer,lock	2	
18	A50A4-40000	转向器 Redirector	1	
19	A30A6-00006	调整垫 Shim	1	
20	GB/T5783	螺栓M6×35 Bolt	4	
21	A30A6-00007	垫片 Washer	4	
22	A30A6-00008	套管 Spacer	4	

转向操纵 Steering control

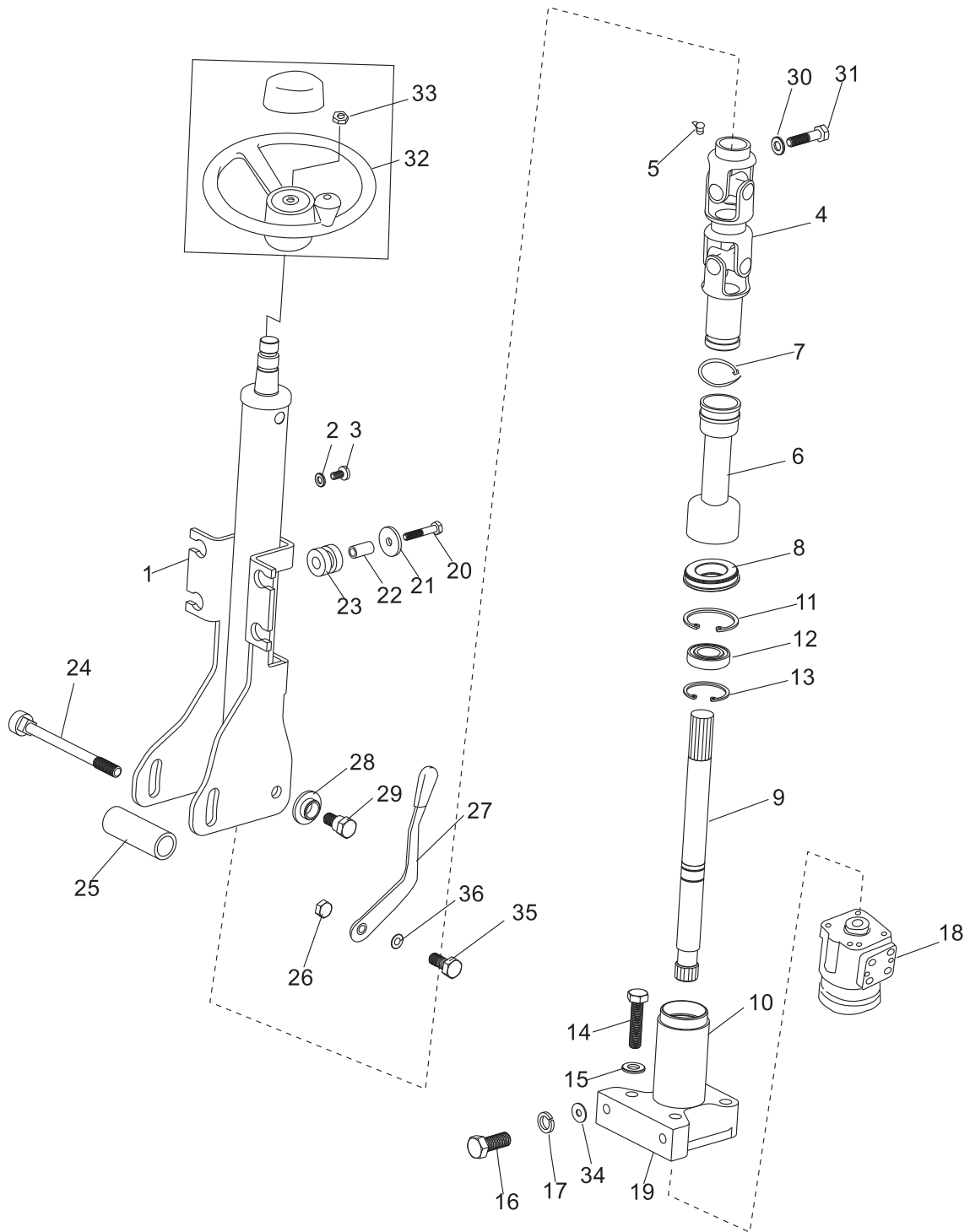

转向操纵
Steering control

序号 Item	零件号 Part No	零部件名称 Description	数量 Q'ty	备注 Remark
23	A30A6-00009	橡胶套 Rubber	4	
24	A30B6-00001	螺栓 Bolt	1	
25	A30C6-00002	管套 I Spacer	1	
26	A30B6-00002	螺母 Nut	1	
27	A30B6-00101	手柄总成 Lever	1	
28	A30A6-00004	垫圈 Washer	2	
29	A30A6-00005	螺栓 Bolt	2	
30	GB/T93	弹垫 8 Washer,lock	1	
31	GB/T5783	螺栓M8×35 Bolt	1	
32	A50A6-00300	方向盘总成 Wheel,Steering ass'y	1	
33	GB/T6173	螺母M16×1.5 Nut	1	
34	GB/T97.1	平垫12 Washer	1	
35	A30B6-00004	螺栓 Bolt	1	
36	A30B6-00003	垫片 Washer	1	

转向桥
Steering axle

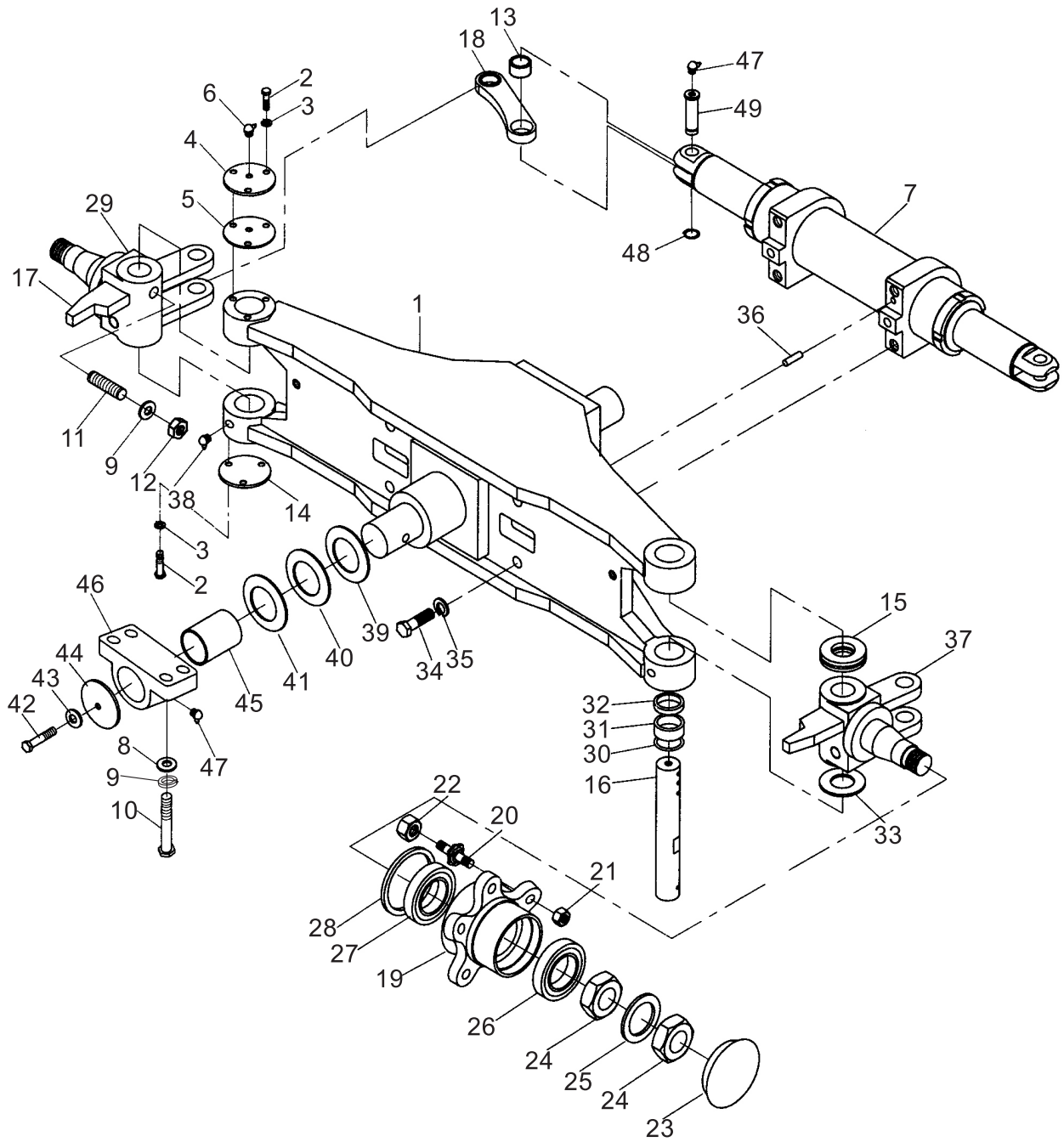

转向桥 Steering axle

序号 Item	零件号 Part No	零部件名称 Description	数量 Q'ty	备注 Remark
1	A50A6-10200	转向桥总成 Axle ass'y	1	
2	GB/T5783	螺栓M8×16 Bolt	12	
3	GB/T93	弹垫8 Washer,lock	12	
4	A50A6-10201	主销盖 Cap,hub	2	
5	A50A6-10202	密封垫片 Washer	2	
6	ZBT33001.2	弯颈式滑脂嘴 Fitting,grease	2	
7	A50A6-10400	转向油缸总成 Power cylinder ass'y	1	
8	GB/T97.1	平垫16 Washer,lock	8	
9	GB/T93	弹垫16 Washer,lock	10	
10	GB/T5783	螺栓M16×65 Bolt	8	
11	GB/T78	螺钉M16×50 Screw	2	
12	GB/T6170	螺母M16 Nut	2	
13	GB/T9163	轴承GE30ES Bearing	4	
14	A50A6-10203	主销下盖 Nut	2	
15	A50A6-10204	止推轴承 Bearing	2	
16	A50A6-10205	转向节主销 Pin,king	2	
17	A50A6-10206	限位板 Board	2	
18	A50A6-10207	连杆 Link	2	
19	A50A6-10208	轮毂8. 25-15-14PR Hub	2	
20	A50A6-10209	轮毂螺栓 Bolt,hub	12	
21	A50A6-10210	轮毂螺母 Nut,hub	12	
22	GB/T6171	螺母M20×1.5 Nut	12	
23	A50A6-10211	轮毂盖 Cap, hub	2	
24	GB/T812	螺母M55×2 Nut	4	
25	GB/T858	垫圈55 Washer	2	

转向桥
Steering axle

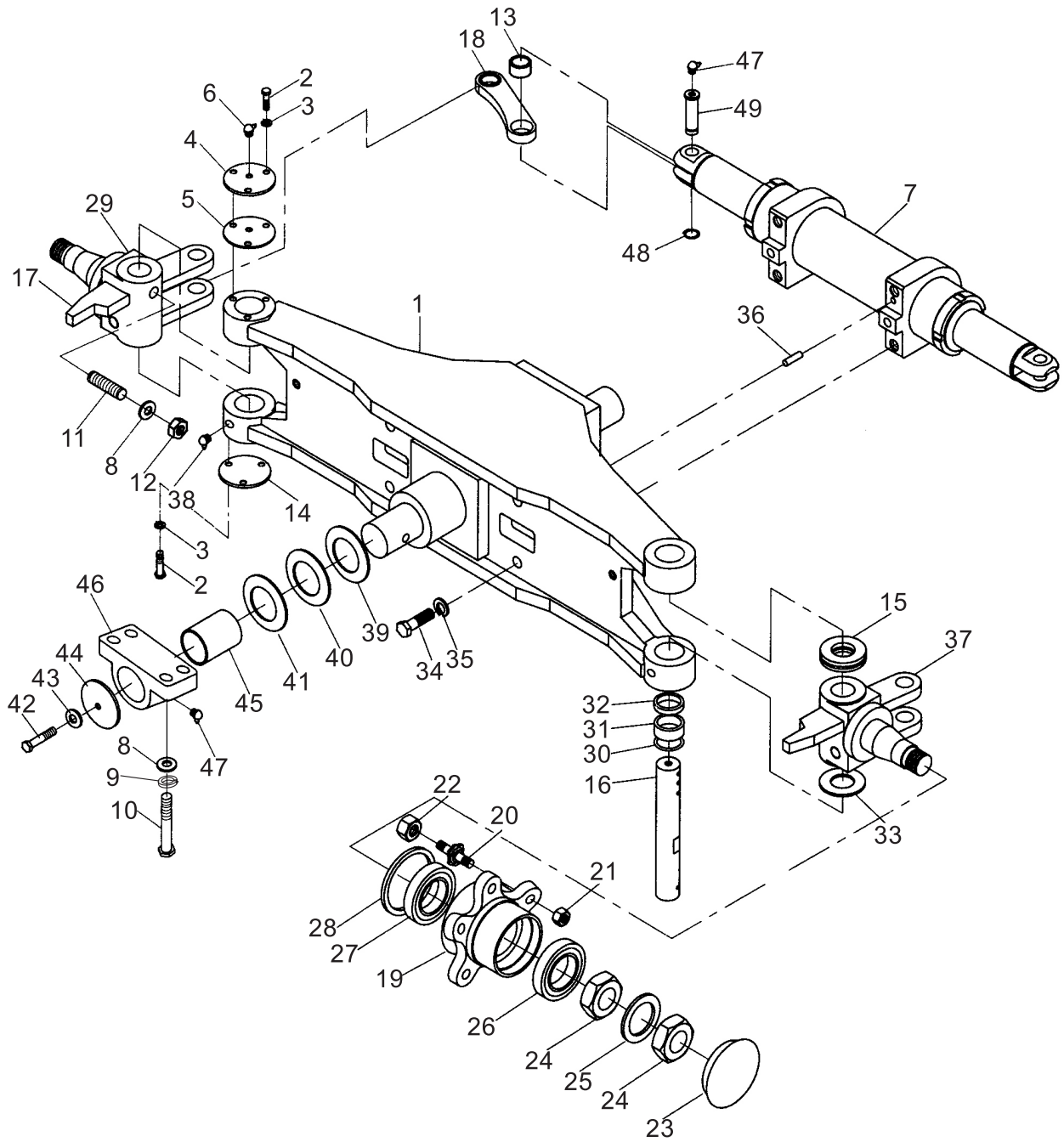

转向桥 Steering axle

序号 Item	零件号 Part No	零部件名称 Description	数量 Q'ty	备注 Remark
26	GB/T297	轴承32211 Bearing	2	
27	GB/T297	轴承32215 Bearing	2	
28	GB/T9877.1	U型密封圈B95×130×12D U-ring	2	
29	A50A6-10500(R)	右转向节总成 Knuckle,R.H. ass'y	1	
30	A50A6-10212	油封 Seal, oil	4	
31	A50A6-10213	滚针轴承 Bearing,needle	8	
32	A50A6-10214	隔套 Spacer	2	
33	A50A6-10215	调整垫 Shim	2	
34	GB/T5786	螺栓M20×1.5×55 Bolt	4	
35	GB/T93	弹垫20 Washer,lock	4	
36	GB/T119.1	销B16×32 Pin	2	
37	A50A6-10500(L)	左转向节总成 Knuckle,L.H. assy	1	
38	ZBT33001.1	直通式滑脂嘴 Fitting,grease	2	
39	A50A6-10216	调整垫 Shim	2	
40	A50A6-10217	调整垫 Shim	2	
41	A50A6-10218	调整垫 Shim	2	
42	GB/T5786	螺栓M12×1.5×25 Bolt	2	
43	GB/T93	弹垫12 Washer,lock	2	
44	A50A6-10219	轴端挡板 Plate	2	
45	A50A6-10220	衬套 Bushing	4	
46	A50A6-10221	转向桥座 Bracket	2	
47	ZBT33001.1	直通式滑脂嘴M6 Fitting,grease	4	
48	GB/T894.1	挡圈30 Snap ring	4	
49	A50A6-10222	连杆销 Pin	4	

转向轮
Steering wheel

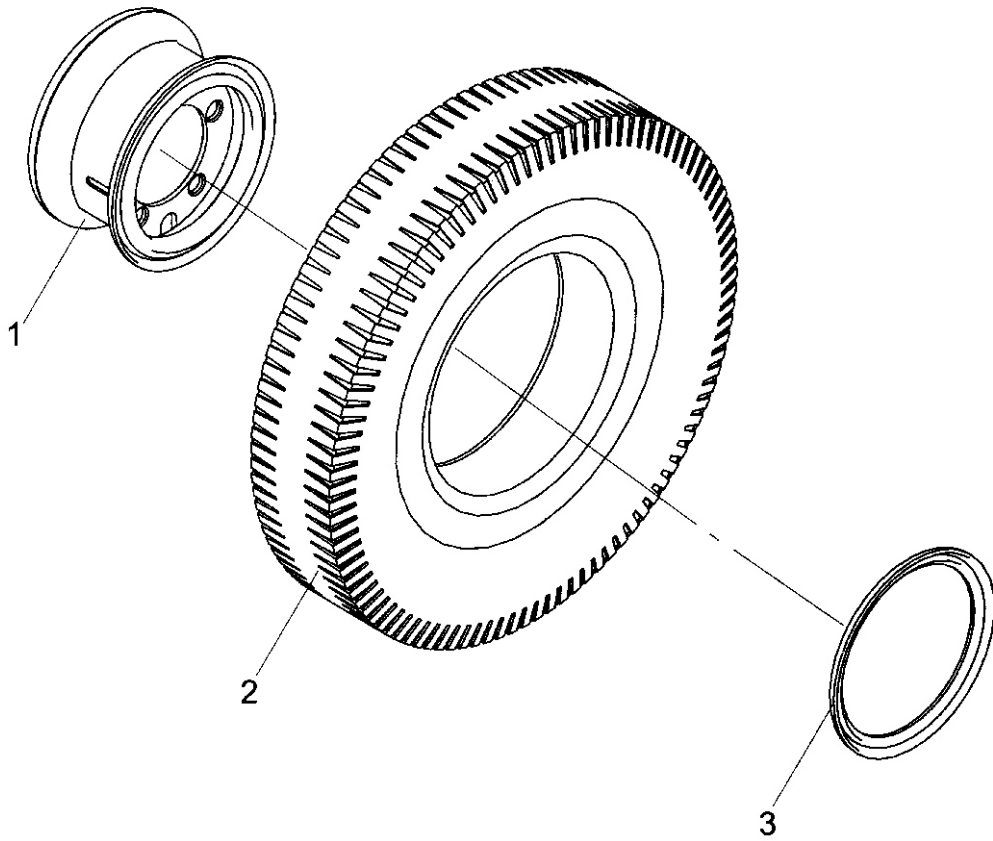

转向轮
Steering wheel

序号 Item	零件号 Part No	零部件名称 Description	数量 Q'ty	备注 Remark
1	A50A6-10300	轮辋总成6.5-15 Rim ass'y	2	
2	GB/T2982	轮胎8.25-15-14PR Tire	2	
3	A50A6-10301	轮胎挡圈 Snap,ring	2	

转向油缸
Steering cylinder

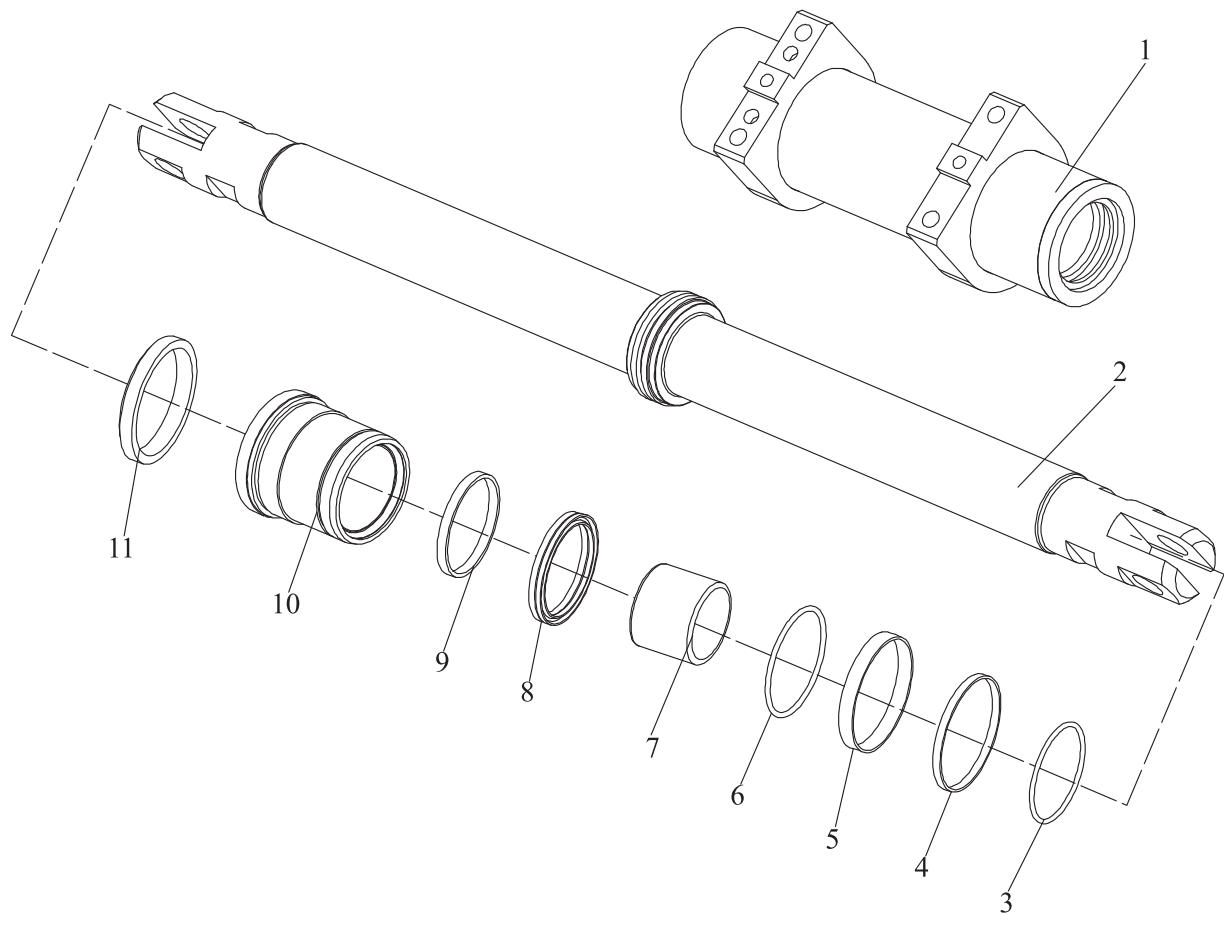

转向油缸 Steering cylinder

序号 Item	零件号 Part No	零部件名称 Description	数量 Q'ty	备注 Remark
A	A50A6-10400	转向油缸 Power cylinder	1	
1	A50A6-10405	缸筒体 Body, steering cylinder	1	
2	A50A6-10600	活塞杆总成 Piston rod ass'y	1	
3	GB/T1235	O型圈d110×5.7 O-ring	1	
4	A50A6-10409	支承环 Seal, slipper	1	
5	A50A6-10410	导向套支承环 Sear, slipper	2	
6	GB/T1235	O型圈d109.4×3.1 O-ring	2	
7	A50A6-10408	钢背轴承85×90×80 Bushing	2	
8	A50A6-10403	密封圈d85×100×9 U-ring	2	
9	A50A6-10402	挡圈d85×100×3 Ring, snap	2	
10	A50A6-10407	导向套 Guide	2	
11	A50A6-10401	防尘圈d85×97.2×7.1 Dust ring	2	

四、油门操纵

ACCELERATOR PEDAL

油门操纵
Accelerator pedal

FD50,60,70,80-CY1/YC2

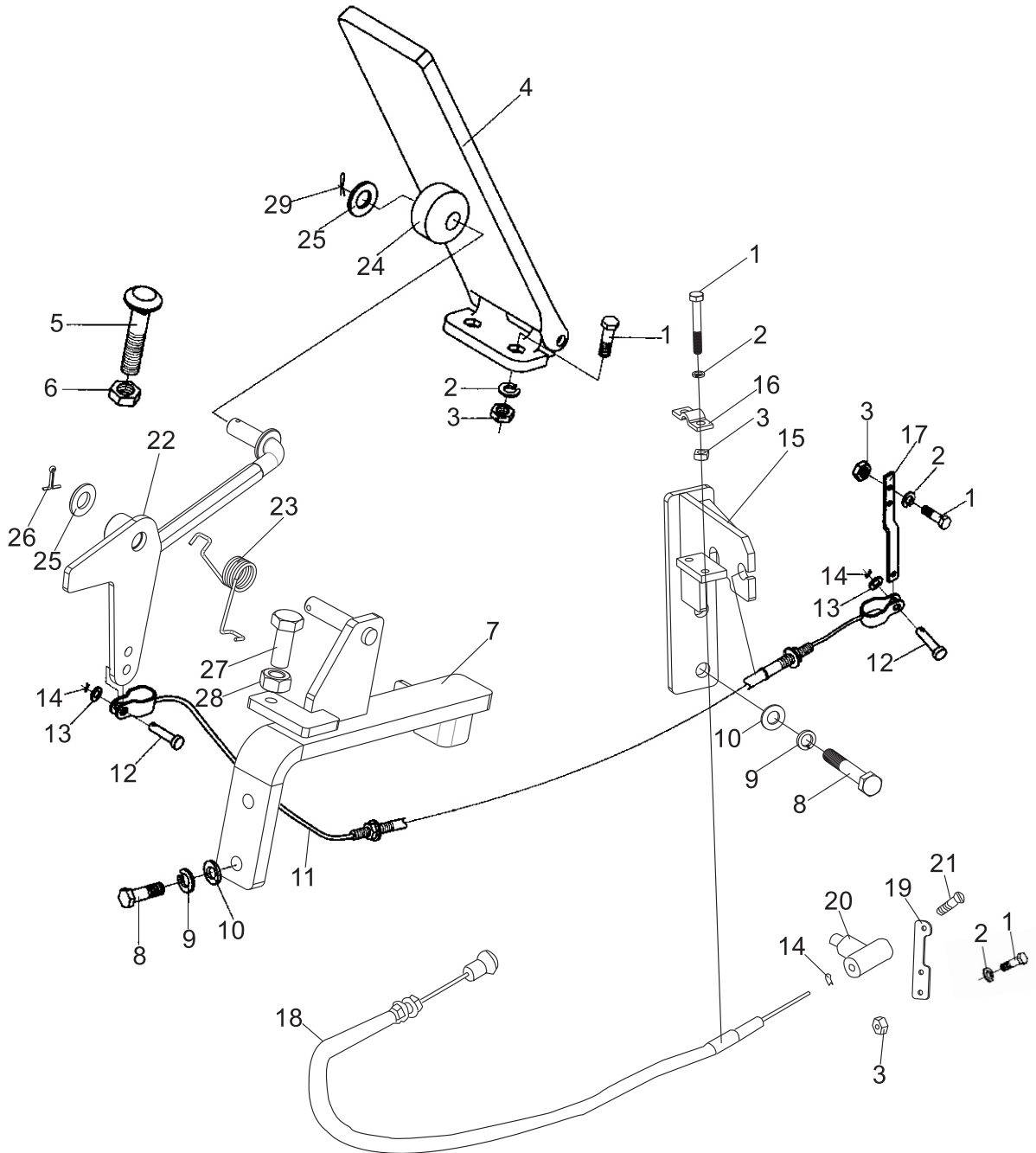

油门操纵
Accelerator pedal

FD50,60,70,80-CY1/YC2

序号 Item	零件号 Part No	零部件名称 Description	数量 Q'ty	备注 Remark
1	GB/T5783	螺栓M6×20 Bolt	8	
2	GB/T93	弹垫6 Washer,lock	8	
3	GB/T6170	螺母M6 Nut	8	
4	A30A7-30100	踏板总成 Accelerator pedal ass'y	1	
5	A30A7-30002	螺栓 Bolt	1	
6	GB/T6170	螺母M12 Nut	1	
7	A50A7-30110	支架体 Bracket	1	
8	GB/T5783	螺栓M10×35 Bolt	4	
9	GB/T93	弹垫10 Washer,lock	4	
10	GB/T97.1	平垫10 Washer	4	
11	A50A7-30400	油门拉索总成 Soft shaft ass'y	1	FD50,60,70,80-CY1
-	A50G7-30400	油门拉索总成 Soft shaft ass'y	1	FD50,60,70,80-YC2
12	GB/T882	销6×16 Pin	2	
13	GB/T97.1	平垫6 Washer	2	
14	GB/T91	销1.6×20 Pin	3	
15	A50A7-30500	支架 Bracket	1	FD50,60,70,80-CY1
-	A50G7-30500	支架 Bracket	1	FD50,60,70,80-YC2
16	A50A7-30001	压板 Pressure plate	1	
17	A50A7-30002	油门拉杆 Link	1	
18	A50A7-30600	熄火拉索总成 Pedal	1	FD50,60,70,80-CY1
-	A50G7-30600	熄火拉索总成 Pedal	1	FD50,60,70,80-YC2
19	A50A7-30003	熄火拉杆 Link	1	
20	A30A7-30008	耳子 Clevis	1	
21	GB/T29.2	十字槽螺栓M5×10 Bolt	1	
22	A50A7-30120	连接轴总成 Link, ass'y	1	

油门操纵
Accelerator pedal

FD50,60,70,80-CY1/YC2

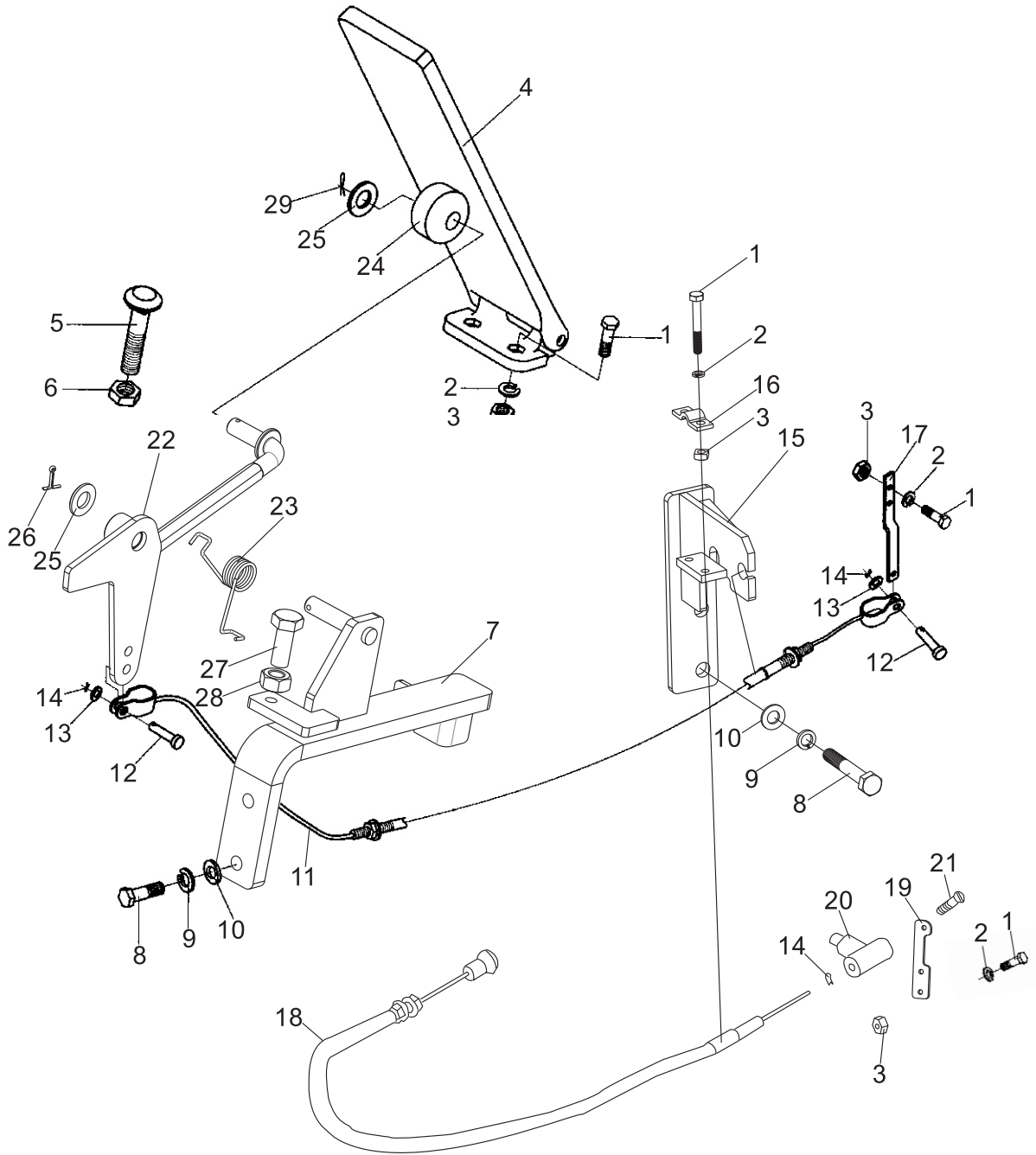

油门操纵
Accelerator pedal

FD50,60,70,80-CY1/YC2

序号 Item	零件号 Part No	零部件名称 Description	数量 Q'ty	备注 Remark
23	A50A7-30105	弹簧 Spring	1	
24	A30A7-30001	滚轮 Sheave	1	
25	GB/T97.1	平垫10 Washer	2	
26	GB/T91	开口销2×25 Pin	1	
27	GB/T5783	螺栓M10×25 Bolt	1	
28	GB/T6170	螺母M12 Nut	1	
29	GB/T91	开口销2.5×20 Pin	1	

油门操纵
Accelerator pedal

FD50,60,70,80-W3

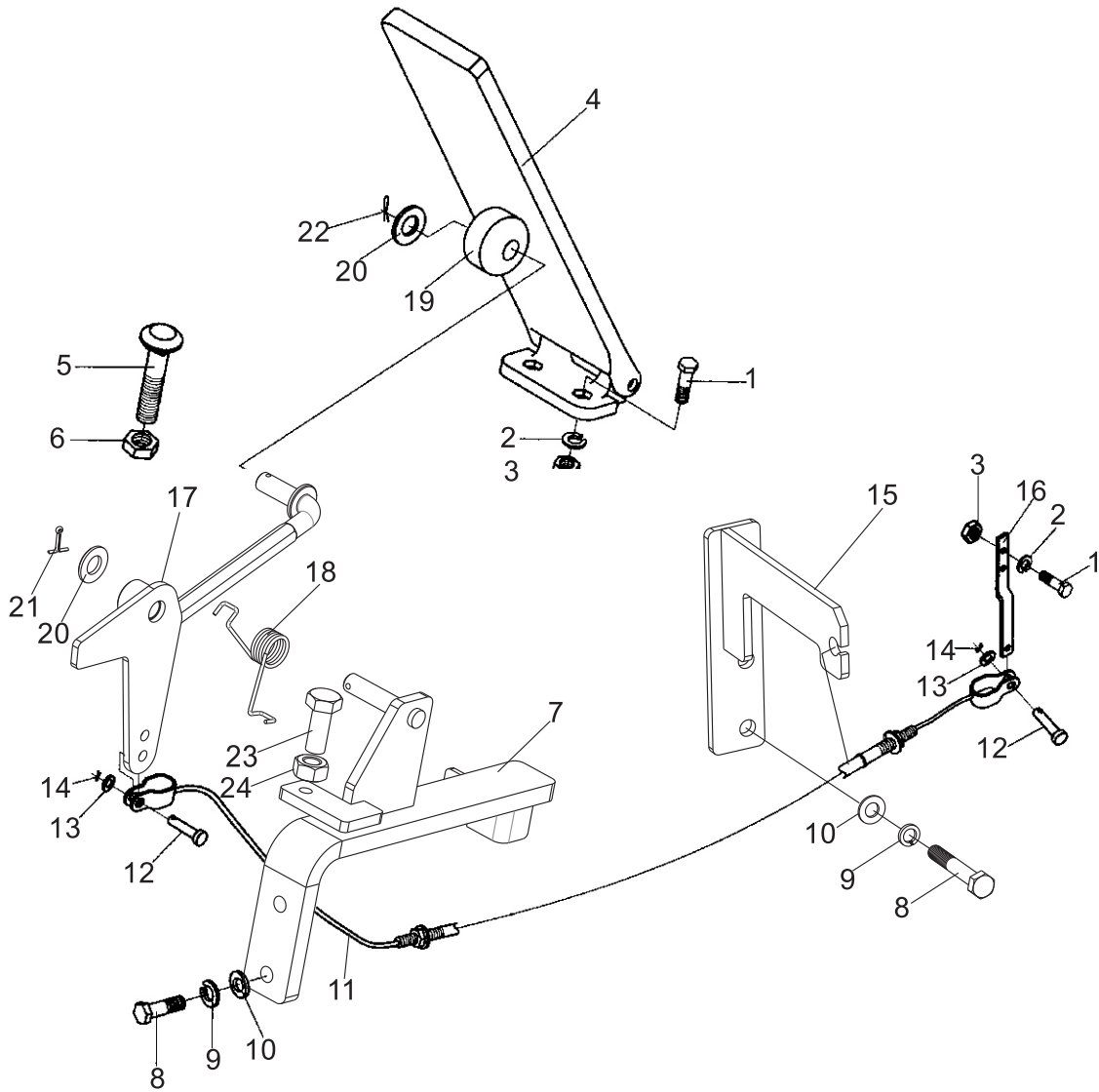

油门操纵
Accelerator pedal

FD50,60,70,80-W3

序号 Item	零件号 Part No	零部件名称 Description	数量 Q'ty	备注 Remark
1	GB/T5783	螺栓M6×20 Bolt	4	
2	GB/T93	弹垫6 Washer,lock	4	
3	GB/T6170	螺母M6 Nut	4	
4	A30A7-30100	踏板总成 Accelerator pedal ass'y	1	
5	A30A7-30002	螺栓 Bolt	1	
6	GB/T6170	螺母M12 Nut	1	
7	A50A7-30110	支架体 Bracket	1	
8	GB/T5783	螺栓M10×35 Bolt	4	
9	GB/T93	弹垫10 Washer,lock	4	
10	GB/T97.1	平垫10 Washer	4	
11	A50A7-30400	油门拉索总成 Soft shaft ass'y	1	
12	GB/T882	销6×16 Pin	2	
13	GB/T97.1	平垫6 Washer	2	
14	GB/T91	销1.6×20 Pin	2	
15	A50B7-30100	支架 Bracket	1	
16	A50A7-30002	油门拉杆 Link	1	
17	A50A7-30120	连接轴总成 Link, ass'y	1	
18	A50A7-30105	弹簧 Spring	1	
19	A30A7-30001	滚轮 Sheave	1	
20	GB/T97.1	平垫10 Washer	2	
21	GB/T91	开口销2×25 Pin	1	
22	GB/T91	开口销2.5×20 Pin	1	
23	GB/T5783	螺栓M10×25 Bolt	1	
24	GB/T6170	螺母M12 Nut	1	

油门操纵
Accelerator pedal

FD50,60,70,80-S3

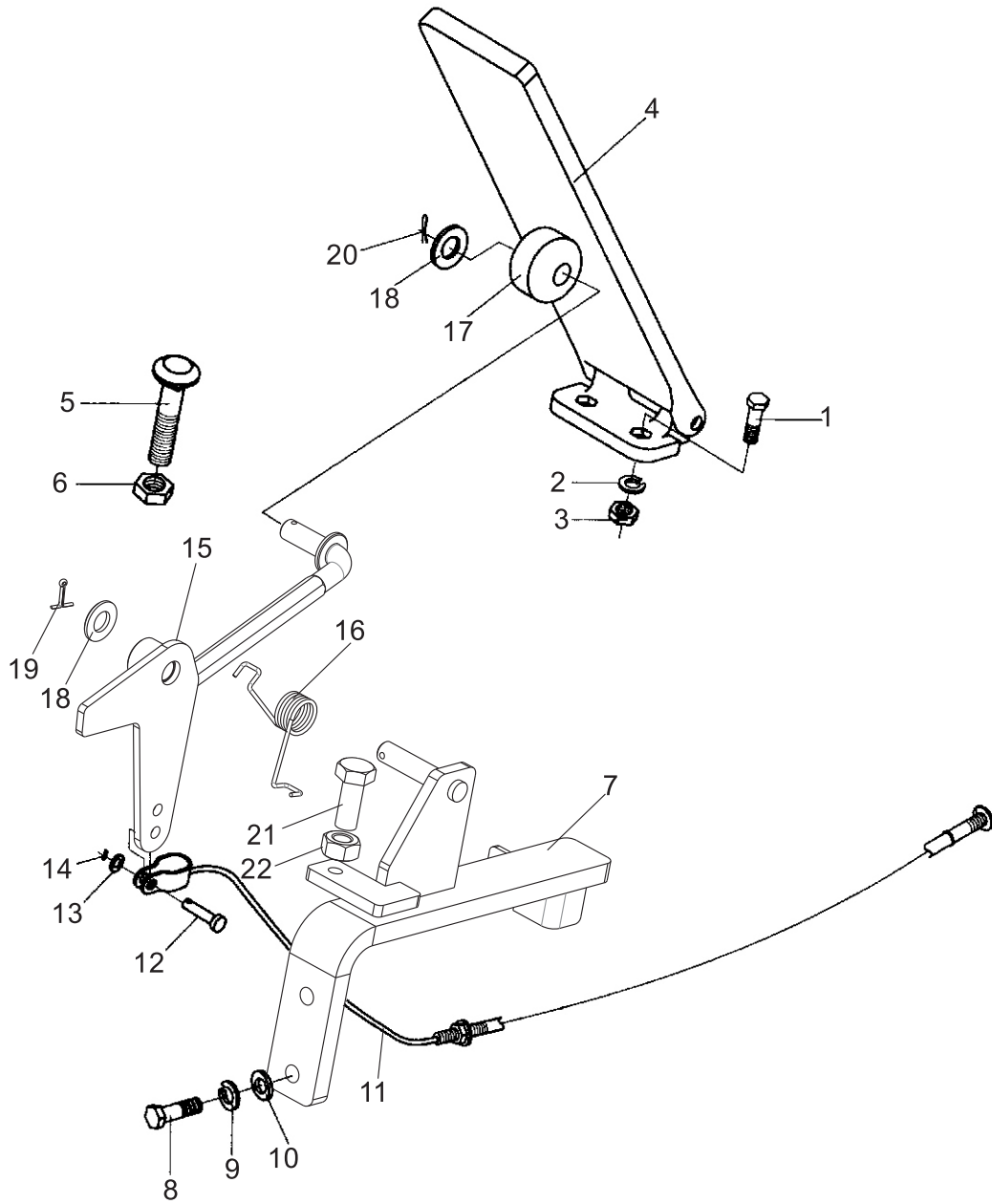

油门操纵
Accelerator pedal

FD50,60,70,80-S3

序号 Item	零件号 Part No	零部件名称 Description	数量 Q'ty	备注 Remark
1	GB/T5783	螺栓M6×20 Bolt	2	
2	GB/T93	弹垫6 Washer,lock	2	
3	GB/T6170	螺母M6 Nut	2	
4	A30A7-30100	踏板总成 Accelerator pedal ass'y	1	
5	A30A7-30002	螺栓 Bolt	1	
6	GB/T6170	螺母M12 Nut	1	
7	A50A7-30110	支架体 Bracket	1	
8	GB/T5783	螺栓M10×35 Bolt	2	
9	GB/T93	弹垫10 Washer,lock	2	
10	GB/T97.1	平垫10 Washer	2	
11	A50E7-30100	油门拉索总成 Soft shaft ass'y	1	
12	GB/T882	销6×16 Pin	1	
13	GB/T97.1	平垫6 Washer	1	
14	GB/T91	销1.6×20 Pin	1	
15	A50A7-30120	连接轴总成 Link, ass'y	1	
16	A50A7-30105	弹簧 Spring	1	
17	A30A7-30001	滚轮 Sheave	1	
18	GB/T97.1	平垫10 Washer	2	
19	GB/T91	开口销2×25 Pin	1	
20	GB/T91	开口销2.5×20 Pin	1	
21	GB/T5783	螺栓M10×25 Bolt	1	
22	GB/T6170	螺母M12 Nut	1	

油门操纵
Accelerator pedal

FY50,60,70,80-G3

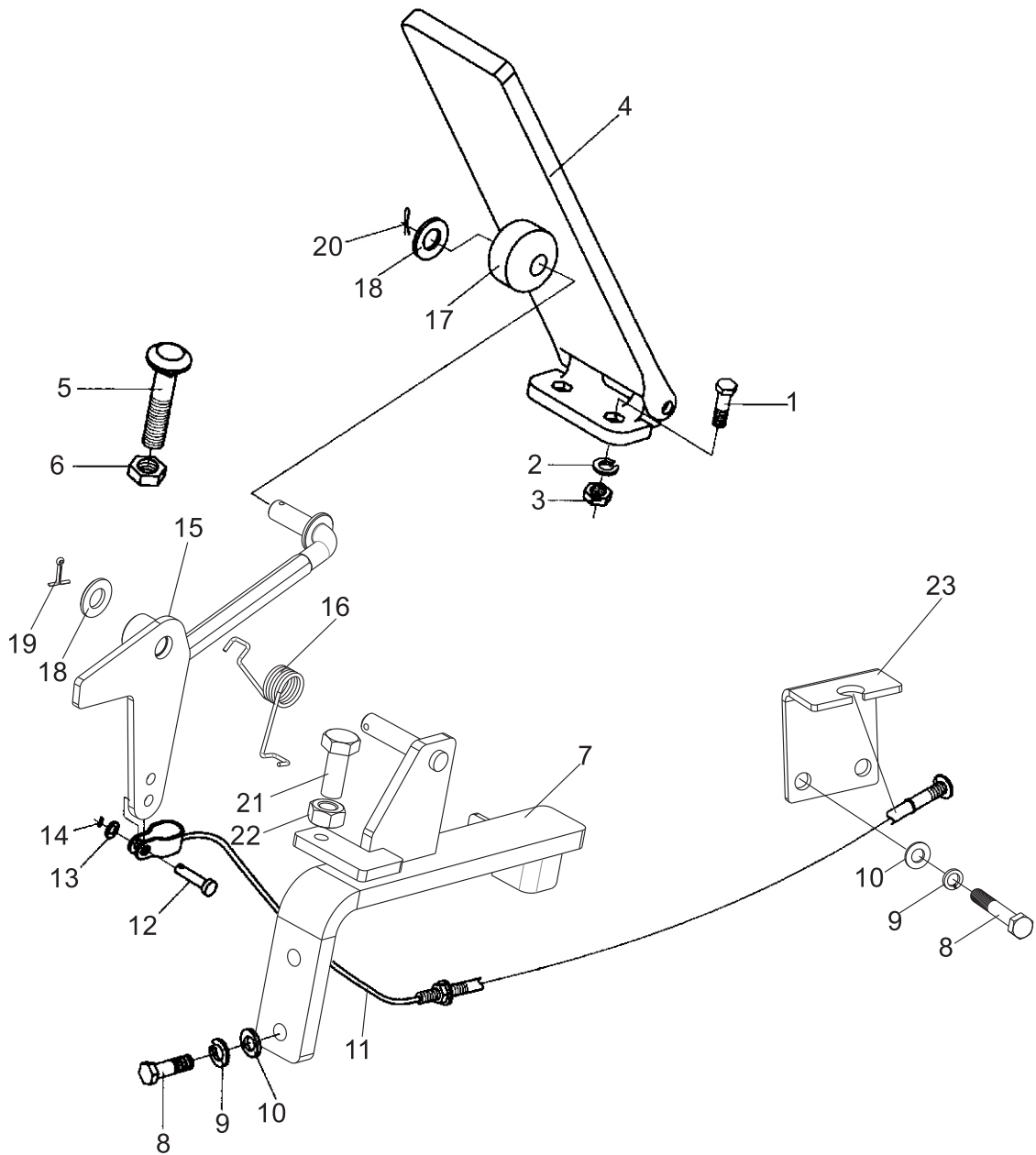

油门操纵
Accelerator pedal

FY50,60,70,80-G3

序号 Item	零件号 Part No	零部件名称 Description	数量 Q'ty	备注 Remark
1	GB/T5783	螺栓M6×20 Bolt	2	
2	GB/T93	弹垫6 Washer,lock	2	
3	GB/T6170	螺母M6 Nut	2	
4	A30A7-30100	踏板总成 Accelerator pedal ass'y	1	
5	A30A7-30002	螺栓 Bolt	1	
6	GB/T6170	螺母M12 Nut	1	
7	A50A7-30110	支架体 Bracket	1	
8	GB/T5783	螺栓M10×35 Bolt	4	
9	GB/T93	弹垫10 Washer,lock	4	
10	GB/T97.1	平垫10 Washer	4	
11	A50F7-30100	油门拉索总成 Soft shaft ass'y	1	
12	GB/T882	销6×16 Pin	1	
13	GB/T97.1	平垫6 Washer	1	
14	GB/T91	销1.6×20 Pin	1	
15	A50A7-30120	连接轴总成 Link, ass'y	1	
16	A50A7-30105	弹簧 Spring	1	
17	A30A7-30001	滚轮 Sheave	1	
18	GB/T97.1	平垫10 Washer	2	
19	GB/T91	开口销2×25 Pin	1	
20	GB/T91	开口销2.5×20 Pin	1	
21	GB/T5783	螺栓M10×25 Bolt	1	
22	GB/T6170	螺母M12 Nut	1	
23	A50F7-30001	油门拉索支架 Bracket	1	

五、制动系统

BRAKE SYSTEM

行车制动与微动操纵
Brake & inching control

FD50,60,70,80-CY1/W3

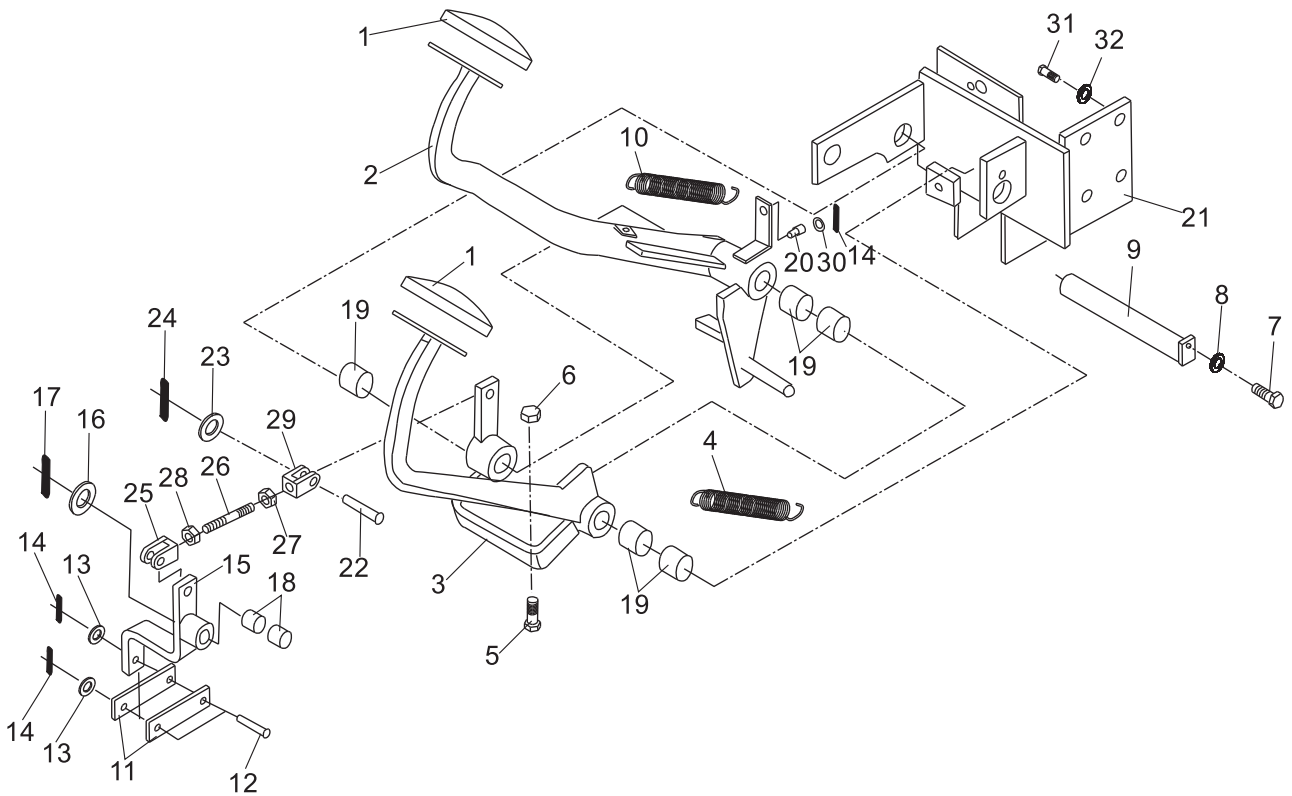

行车制动与微动操纵
Brake & inching control

FD50,60,70,80-CY1/W3

序号 Item	零件号 Part No	零部件名称 Description	数量 Q'ty	备注 Remark
1	A30A7-11001	踏板套 Head cover	2	
2	A50A7-12200	制动踏板总成 Pedal, brake	1	
3	A50A7-12100	微动踏板总成 Pedal, inching	1	
4	A50A7-12001	微动拉簧 Spring	1	
5	GB/T6170	螺母M10 Nut	3	
6	GB/T5783	螺栓M10×40 Bolt	3	
7	GB/T5783	螺栓M8×16 Bolt	1	
8	GB/T97.1	平垫 Washer	1	
9	A50A7-12600	油轴总成 Shaft, oil	1	
10	A50A7-12002	制动拉簧 Spring	1	
11	A50A7-12003	连接板 Link	2	
12	GB/T882	销轴B6×28 Pin	2	
13	GB/T97.1	平垫6 Washer	2	
14	GB/T91	开口销2×16 Pin	3	
15	A50A7-12400	摇臂总成 Link	1	
16	GB/T97.1	平垫16 Washer	1	
17	GB/T91	开口销4×32 Pin	1	
18	A50A7-12004	钢背轴承1620 Bushing	2	
19	A50A7-12005	钢背轴承2525 Bushing	5	
20	A30B7-11002	尼龙垫 Nylon	1	
21	A50A7-12300	托架总成 Bracket	1	

行车制动与微动操纵
Brake & inching control

FD50,60,70,80-CY1/W3

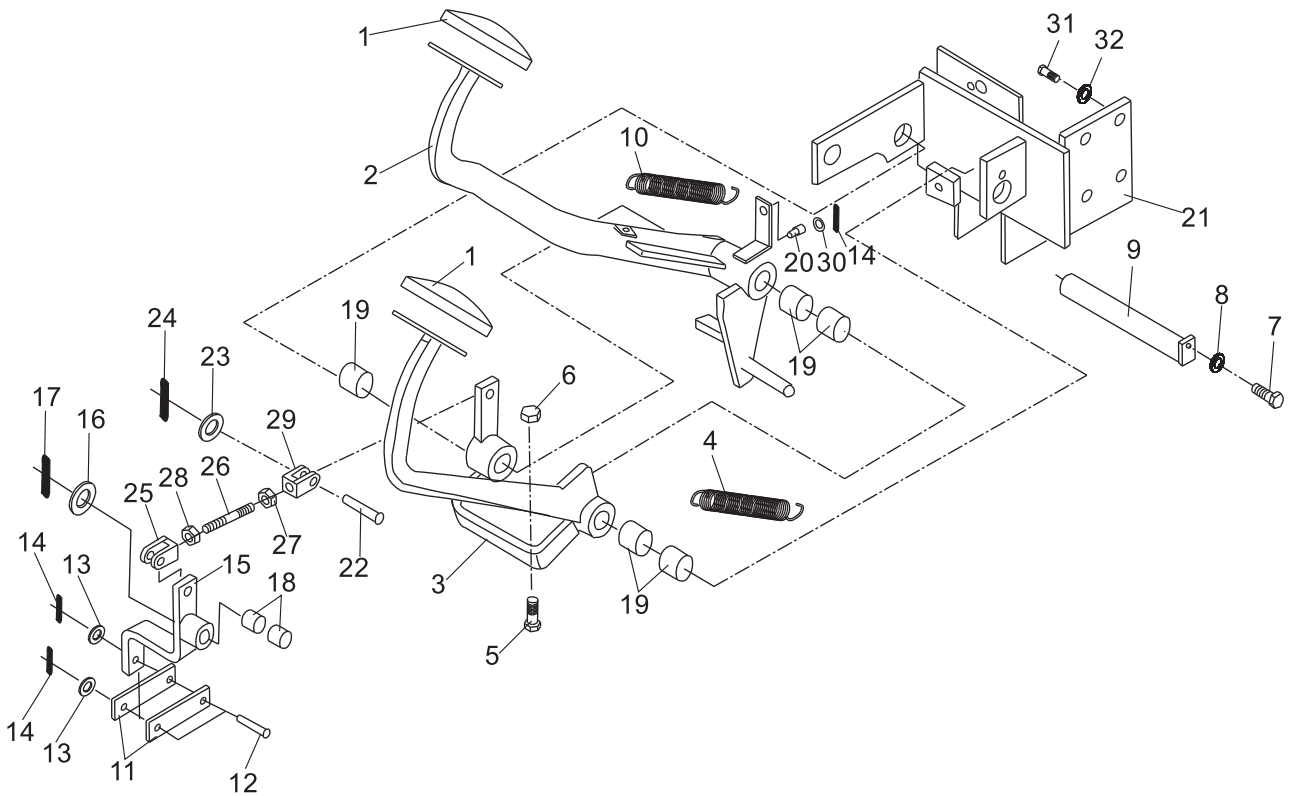

行车制动与微动操纵
Brake & inching control

FD50,60,70,80-CY1/W3

序号 Item	零件号 Part No	零部件名称 Description	数量 Q'ty	备注 Remark
22	GB/T882	销轴B10×30Pin	2	
23	GB/T97.1	平垫10 Washer	2	
24	GB/T91	开口销3.2×22 Pin	2	
25	A30B7-11001	连接头(右旋) clevis	1	
26	A50A7-12501	双头螺杆 Rod	1	
27	GB/T6170	左旋螺母M8 Nut(L. H)	1	
28	GB/T6170	右旋螺母M8 Nut(R. H)	1	
29	A30B7-11004	连接头(左旋) clevis	1	
30	GB/T97.1	平垫8 Washer	1	
31	GB/T5783	螺栓M12×20 Bolt	4	
32	GB/T93	弹垫12 Washer, lock	4	

行车制动与微动操纵
Brake & inching control

FD50,60,70,80-S3/YC2/KMS2
FY50,60,70,80-G3/G4

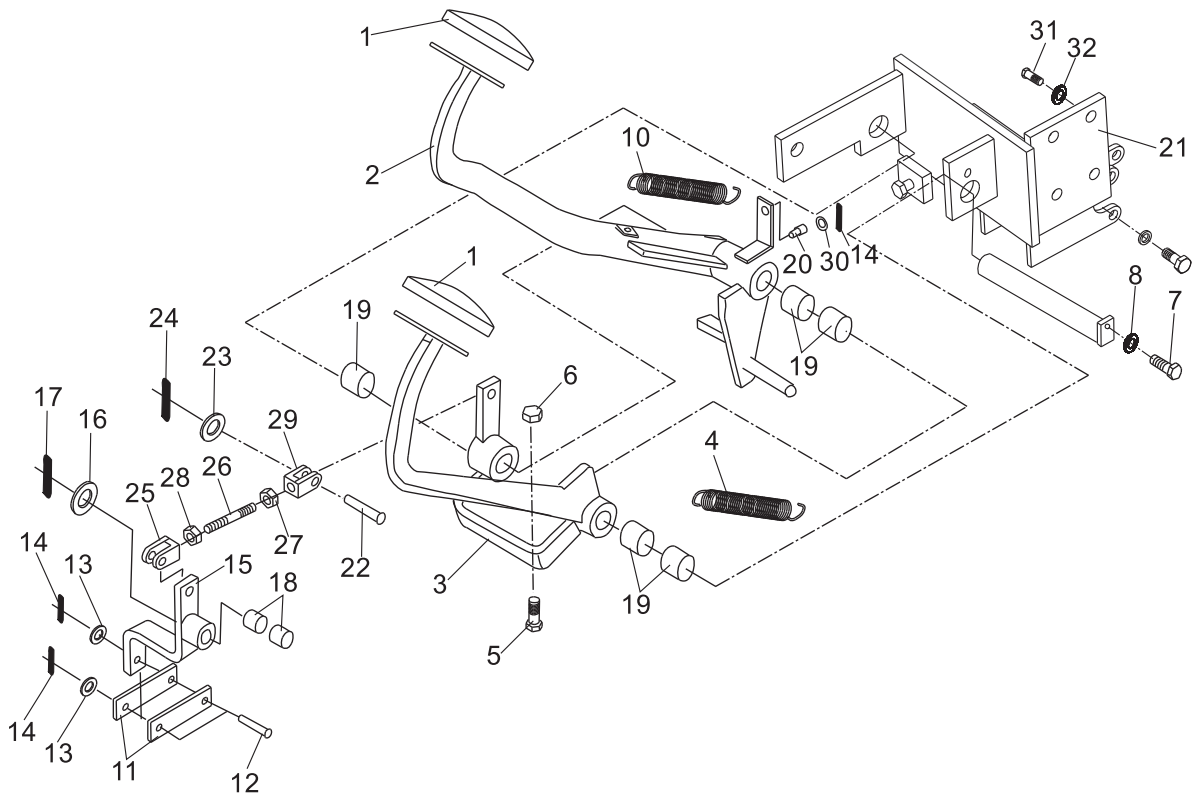

行车制动与微动操纵
Brake & inching control

FD50,60,70,80-S3/YC2/KMS2
FY50,60,70,80-G3/G4

序号 Item	零件号 Part No	零部件名称 Description	数量 Q'ty	备注 Remark
1	A30A7-11001	踏板套 Head cover	2	
2	A90B7-11100	制动踏板总成 Pedal, brake	1	
3	A50A7-12100	微动踏板总成 Pedal, inching	1	
4	A50A7-12001	微动拉簧 Spring	1	
5	GB/T6170	螺母M10 Nut	3	
6	GB/T5783	螺栓M10×40 Bolt	3	
7	GB/T5783	螺栓M8×16 Bolt	1	
8	GB/T97.1	平垫 Washer	1	
9	A50A7-12600	油轴总成 Shaft, oil	1	
10	A50A7-12002	制动拉簧 Spring	1	
11	A50A7-12003	连接板 Link	2	
12	GB/T882	销轴B6×28 Pin	2	
13	GB/T97.1	平垫6 Washer	2	
14	GB/T91	开口销2×16 Pin	3	
15	A90B7-11300	摇臂总成 Link	1	
16	GB/T97.1	平垫16 Washer	1	
17	GB/T91	开口销4×32 Pin	1	
18	A50A7-12004	钢背轴承1620 Bushing	2	
19	A50A7-12005	钢背轴承2525 Bushing	5	
20	A30B7-11002	尼龙垫 Nylon	1	
21	A90B7-11200	托架总成 Bracket	1	

行车制动与微动操纵
Brake & inching control

FD50,60,70,80-S3/YC2/KMS2
FY50,60,70,80-G3/G4

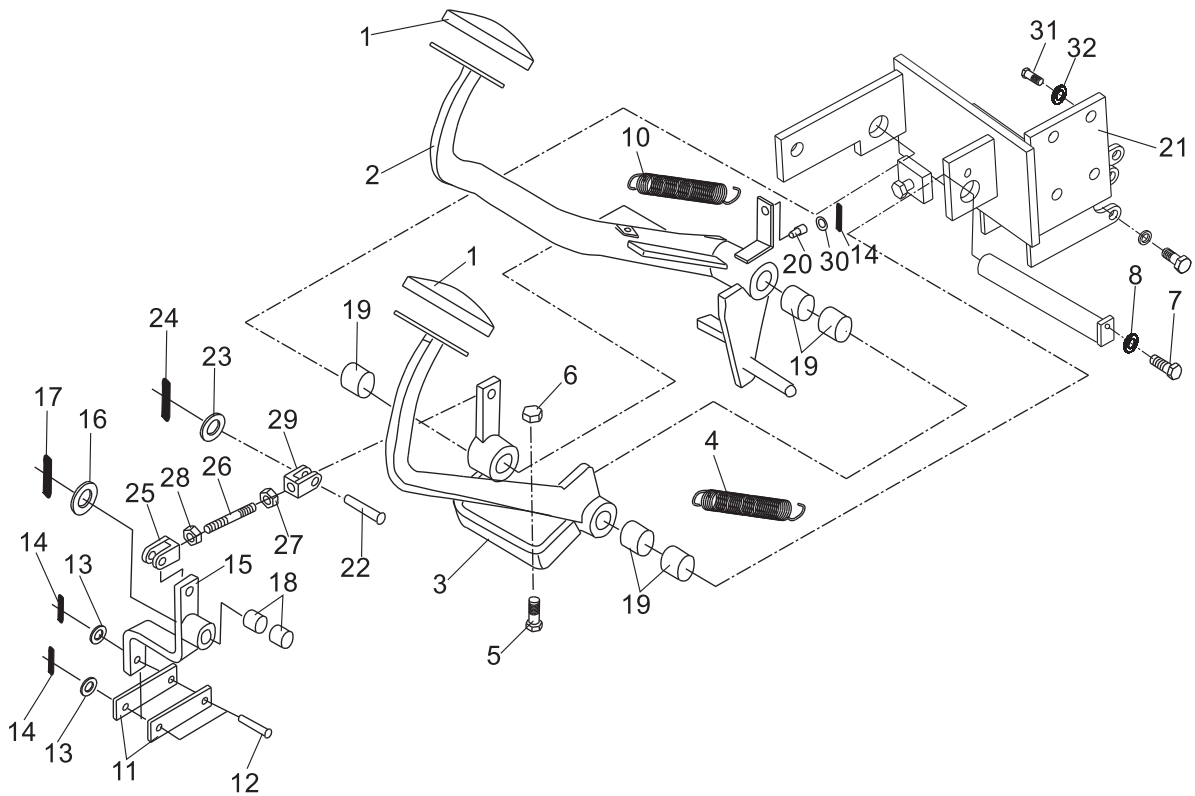

行车制动与微动操纵
Brake & inching control

FD50,60,70,80-S3/YC2/KMS2
FY50,60,70,80-G3/G4

序号 Item	零件号 Part No	零部件名称 Description	数量 Q'ty	备注 Remark
22	GB/T882	销轴B10×30Pin	2	
23	GB/T97.1	平垫10 Washer	2	
24	GB/T91	开口销3.2×22 Pin	2	
25	A30B7-11001	连接头(右旋) clevis	1	
26	A90B7-11401	双头螺杆 Rod	1	
27	GB/T6170	左旋螺母M8 Nut(L. H)	1	
28	GB/T6170	右旋螺母M8 Nut(R. H)	1	
29	A30B7-11004	连接头(左旋) clevis	1	
30	GB/T97.1	平垫8 Washer	1	
31	GB/T5783	螺栓M12×20 Bolt	4	
32	GB/T93	弹垫12 Washer, lock	4	

行车制动管路系统
Brake Piping System

FD50,60,70,80-CY1/W3

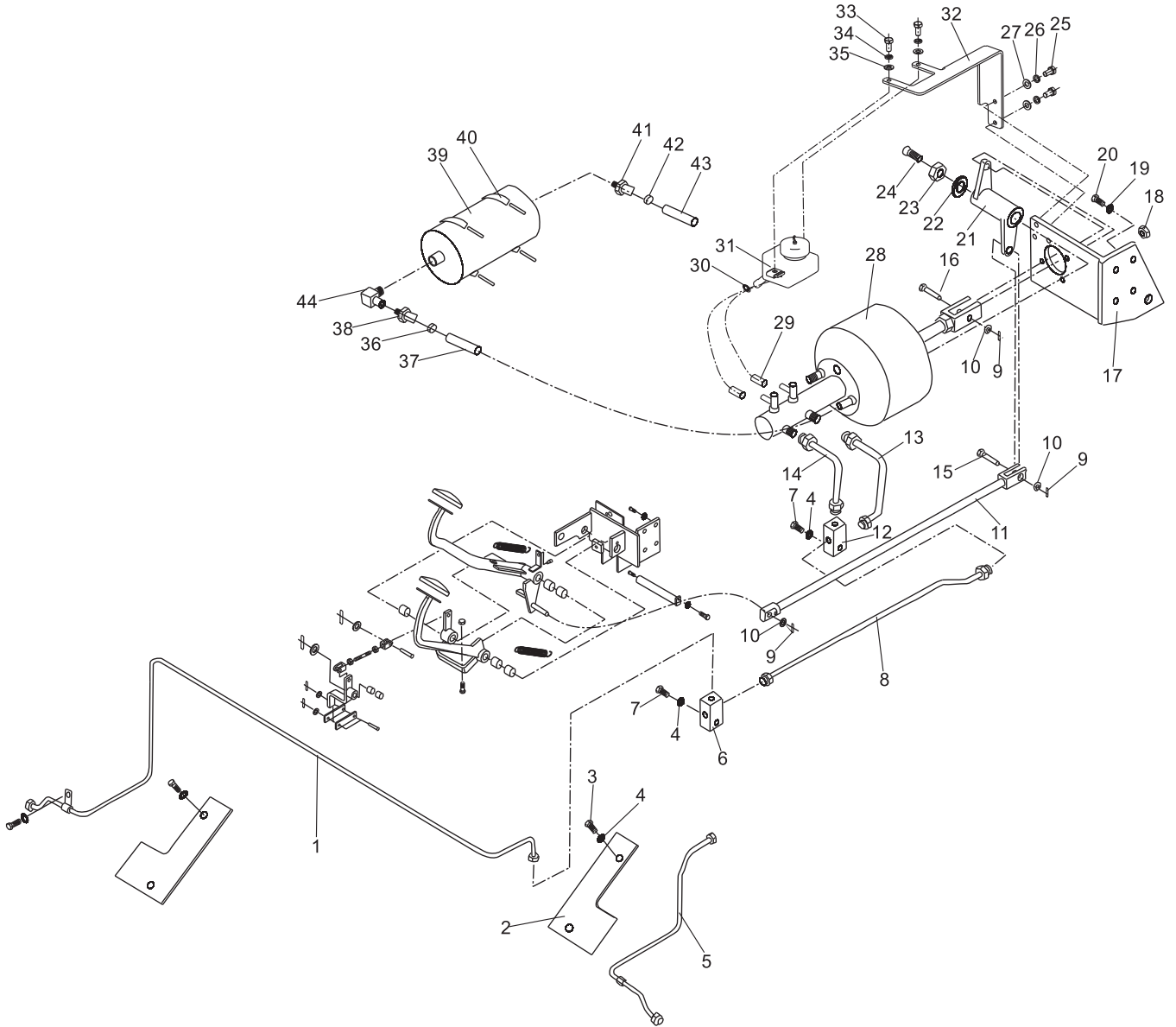

行车制动管路系统
Brake Piping System

FD50,60,70,80-CY1/W3

序号 Item	零件号 Part No	零部件名称 Description	数量 Q'ty	备注 Remark
1	A50A7-10100	油管总成(B) Pipe ass'y	1	
2	A50A7-10001	护板 Guard	2	
3	GB/T5786	螺栓 M10×1.25×20 Bolt	4	
4	GB/T93	弹垫10 Washer, Lock	6	
5	A50A7-10200	油管总成(A) Pipe ass'y	1	
6	GJT-46-00	三通接头 Three way	1	
7	GB/T5783	螺栓 M10×30 Bolt	2	
8	A50A7-10300	油管总成(E) Pipe ass'y	1	
9	GB/T91	开口销3.2×28 Pin	3	
10	GB/T97.1	平垫14 Washer	3	
11	A50A7-10400	连杆总成 Link	1	
12	GJT-45-00	三通接头 Three way	1	
13	A50A7-10500	油管总成(F) Pipe ass'y	1	
14	A50A7-10600	油管总成(G) Pipe ass'y	1	
15	GB/T882	销B14×35 Pin, cotter	1	
16	GB/T882	销B14×28 Pin, cotter	1	
17	A50A7-10710	支架总成 Bracket	1	
18	GB/T6177.1	六角法兰面锁紧螺母M8 Nut	4	
19	GB/T93	弹垫12 Washer, lock	4	
20	GB/T5783	螺栓M12×20 Bolt	4	
21	A50A7-10720	摇臂总成 Link	1	
22	GB/T97.1	平垫20 Washer	1	

行车制动管路系统
Brake Piping System

FD50,60,70,80-CY1/W3

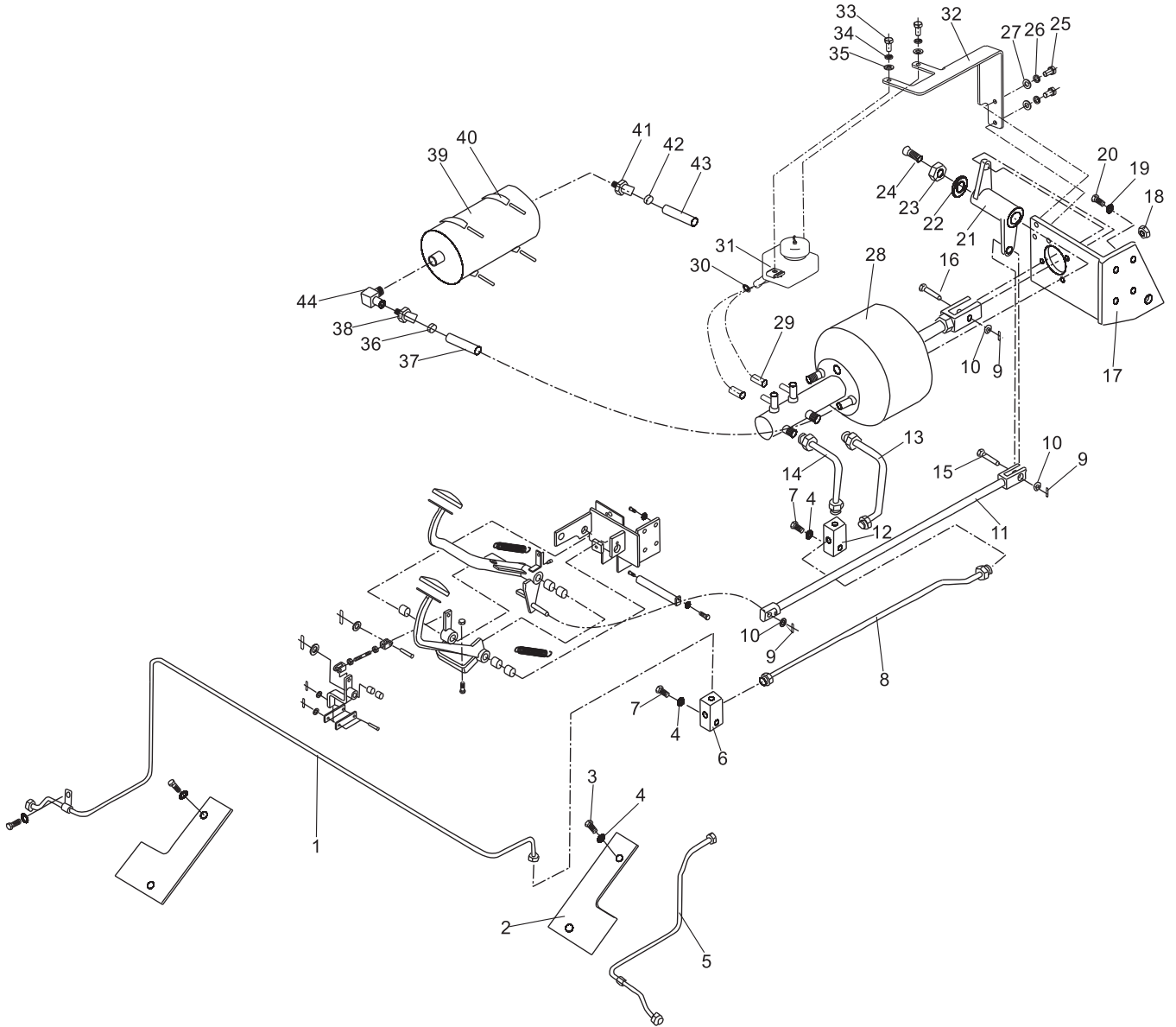

行车制动管路系统
Brake Piping System

FD50,60,70,80-CY1/W3

序号 Item	零件号 Part No	零部件名称 Description	数量 Q'ty	备注 Remark
23	GB/T6170	螺母M20 Nut	1	
24	JB/T7940.2	油杯45° M10×1 Fiting, grease	1	
25	GB/T5783	螺栓M8×16 Bolt	2	
26	GB/T93	弹垫8 Washer, Lock	2	
27	GB/T97.1	平垫8 Washer	2	
28	A50A7-10900	真空助力器&制动泵总成 Hydromaster	1	
29	TG000-10026	胶管 Φ10×260 Hose	2	
30	TK000-10016	卡箍 Φ10-16 Clip	4	
31	A50C7-10100	制动油壶 Reserve tank	1	
32	A50C7-10001	油壶安装支架 Bracket	1	
33	GB/T5783	螺栓M6×16 Bolt	2	
34	GB/T93	弹垫6 Washer, Lock	2	
35	GB/T97.1	平垫6 Washer	2	
36	TK000-13019	卡箍 Φ13-19 Clip	2	
37	TG000-10070	胶管 Φ10×700 Hose	1	
38	GJT-67-00	直通接头 Joint	1	
39	A50A7-11200	真空罐 Vacuum tank	1	
40	A50A7-11300	罐箍 Clip	2	
41	GJT-141-00	直通接头 Joint	1	
42	TK000-22032	卡箍 Φ22-32 Clip	2	
43	TG000-19200	真空管 Φ19×2000 Vacuum hose	1	
44	GJT-140-00	直角接头 Elbow	1	

行车制动管路系统
Brake Piping System

FD50,60,70,80-S3
FY50,60,70,80-G3/G4

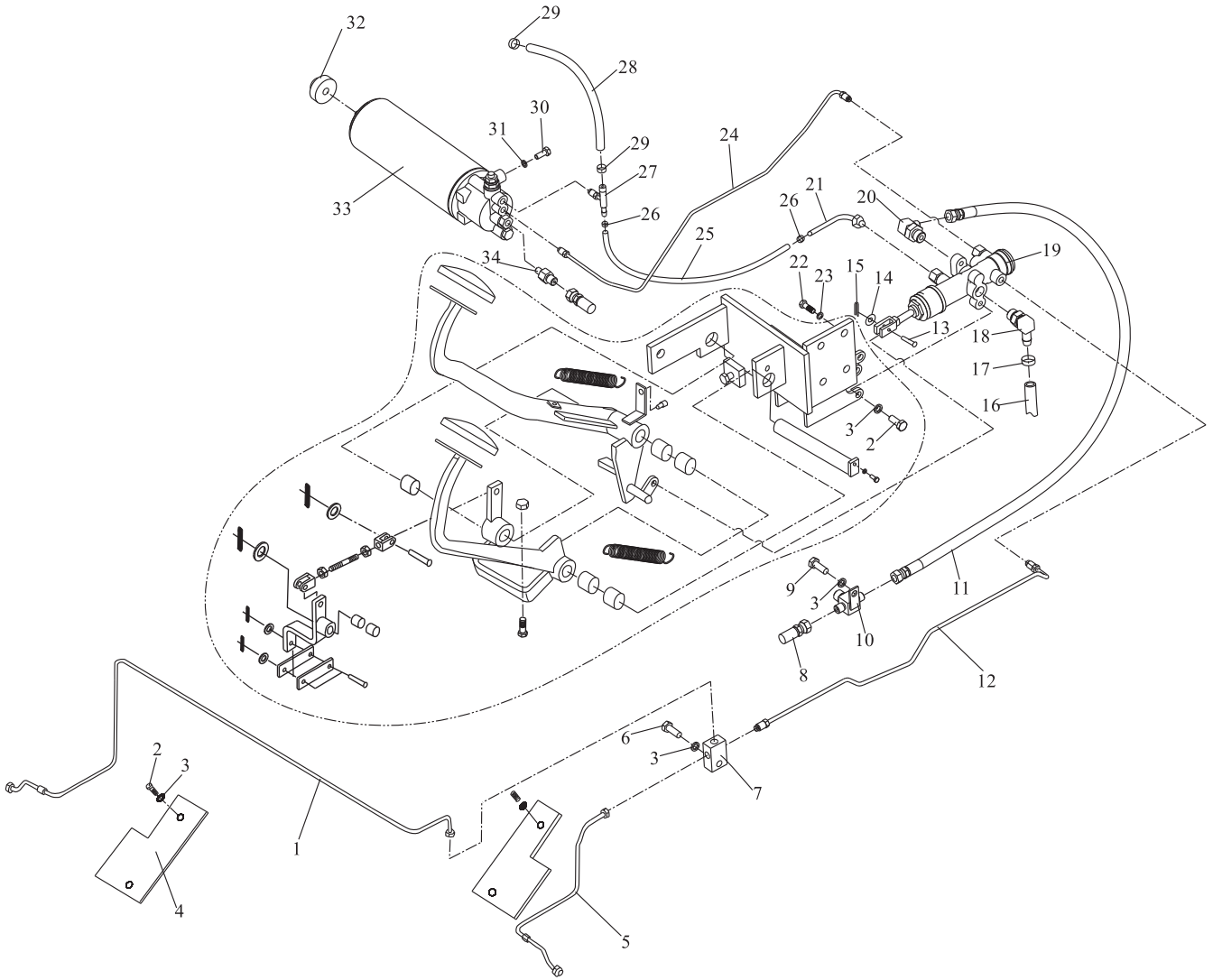

行车制动管路系统
Brake Piping System

FD50,60,70,80-S3
FY50,60,70,80-G3/G4

序号 Item	零件号 Part No	零部件名称 Description	数量 Q'ty	备注 Remark
1	A50A7-10100	油管总成(B) Pipe ass'y	1	
2	GB/T5786	螺栓M10×1.25×20 Bolt	8	
3	GB/T93	弹垫10 Washer, lock	10	
4	A50A7-10001	护板 Board	2	
5	A50A7-10200	油管总成(A) Pipe ass'y	1	
6	GB/T5783	螺栓M10×30 Bolt	1	
7	GJT-46-00	三通接头 Three way	1	
8	TGIBI-08031*G	高压胶管8I×310 Hose H.P.	1	
9	GB/T5783	螺栓M10×15 Bolt	1	
10	GJT-149-00	三通接头 Three way	1	
11	TGIBI-08033*G	高压胶管8I×330 Hose H.P.	1	
12	A90B7-10600	制动钢管F Brake pipe	1	
13	GB/T882	销B10×28 Pin	2	
14	GB/T97.1	平垫10 Washer	2	
15	GB/T91	开口销2.5×28 Pin	2	
16	TG000-13150	低压胶管 φ13×1500 Hose L.P.	1	
17	TK000-16025	卡箍 φ16~φ25 Clip	2	
18	GJT-158-00	直角接头 Elbow	1	
19	A90B7-10700	制动泵总成 Brake pump ass'y	1	
20	GJT-156-00	直角接头 Elbow	1	

行车制动管路系统
Brake Piping System

FD50,60,70,80-S3
FY50,60,70,80-G3/G4

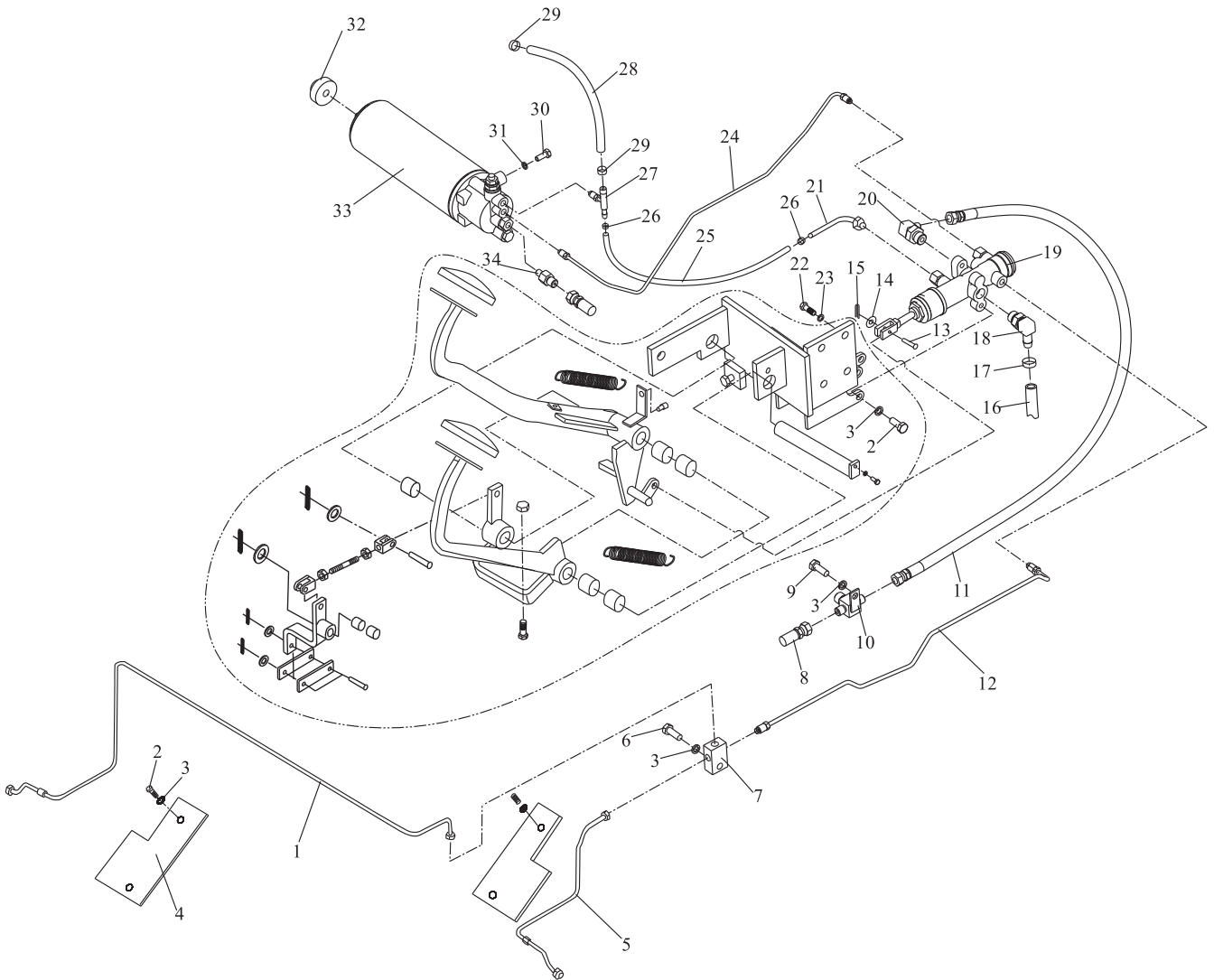

行车制动管路系统
Brake Piping System

FD50,60,70,80-S3
FY50,60,70,80-G3/G4

序号 Item	零件号 Part No	零部件名称 Description	数量 Q'ty	备注 Remark
21	A90B7-10800	弯头钢管 Elbow Pipe	1	
22	GB/T5783	螺栓M12×20 Bolt	4	
23	GB/T93	弹垫12 Washer, lock	4	
24	A70A7-10100	制动钢管 Brake pipe	1	
25	TG000-06050	低压胶管 φ6×500 Hose L.P.	1	
26	TK000-10016	卡箍 φ10~φ16 Clip	2	
27	A90B7-11100	三通钢管 Three steel	1	
28	TG000-10100	低压胶管 φ10×1000 Hose L.P.	1	
29	GB/T5783	卡箍 φ13~φ19 Clip	2	
30	TK000-13019	螺栓M8×20 Bolt	2	
31	GB/T93	弹垫8 Washer, lock	2	
32	A30A5-40003	橡胶垫 I Rubber	1	
33	A90B7-11200	蓄能器总成 Reserve ass'y	1	
34	GJT-159-00	直角接头 Elbow	1	

行车制动管路系统
Brake Piping System

FD50,60,70,80-YC2/KMS2

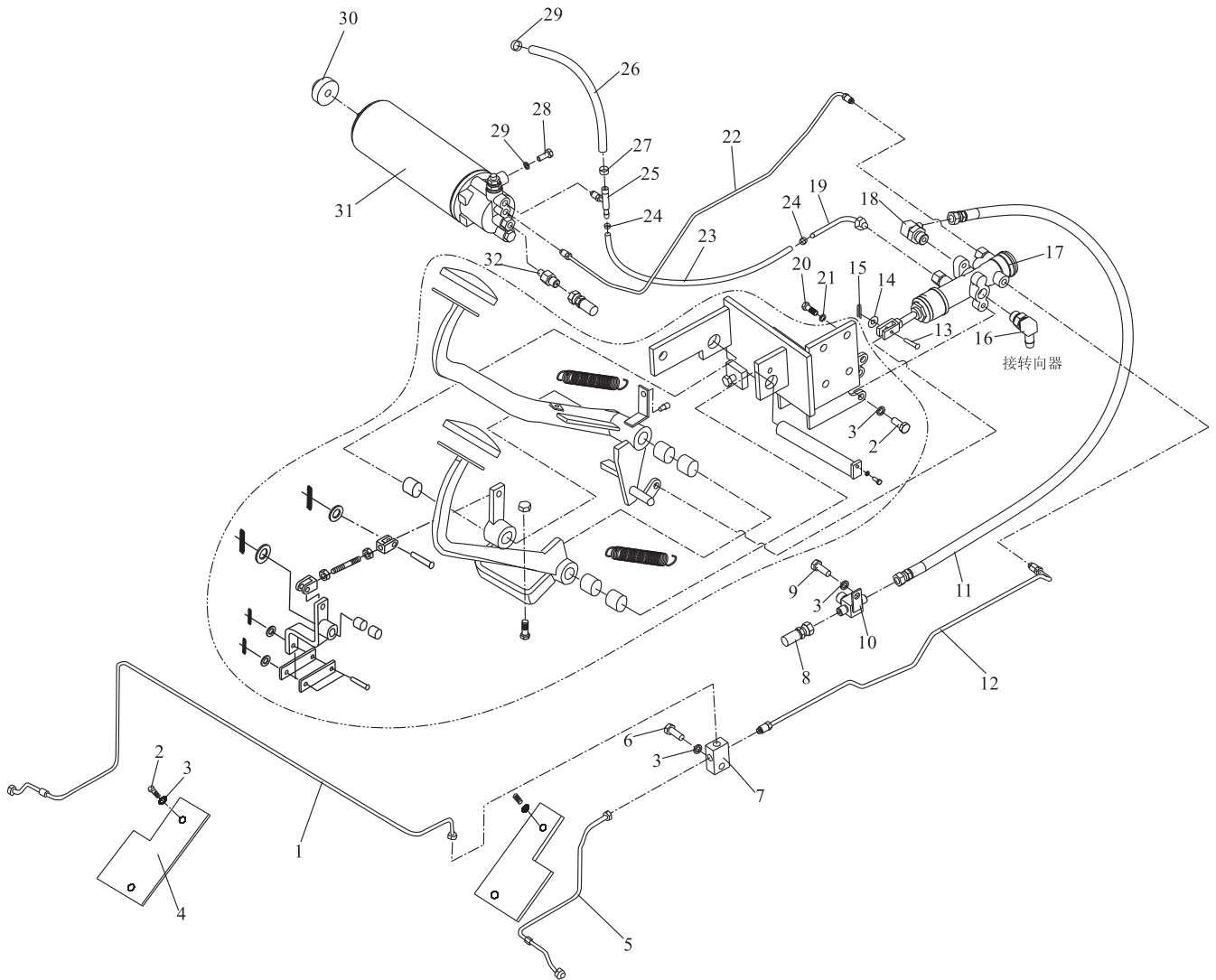

行车制动管路系统
Brake Piping System

FD50,60,70,80-YC2/KMS2

序号 Item	零件号 Part No	零部件名称 Description	数量 Q'ty	备注 Remark
1	A50A7-10100	油管总成(B) Pipe ass'y	1	
2	GB/T5786	螺栓M10×1.25×20 Bolt	8	
3	GB/T93	弹垫10 Washer, lock	10	
4	A50A7-10001	护板 Board	2	
5	A50A7-10200	油管总成(A) Pipe ass'y	1	
6	GB/T5783	螺栓M10×30 Bolt	1	
7	GJT-46-00	三通接头 Three way	1	
8	TGIBI-08031*G	高压胶管8I×310 Hose H.P.	1	
9	GB/T5783	螺栓M10×15 Bolt	1	
10	GJT-149-00	三通接头 Three way	1	
11	TGIBI-08033*G	高压胶管8I×330 Hose H.P.	1	FD50,60,70,80-YC2
-	TGIBI-08043*G	高压胶管8I×430 Hose H.P.	1	FD50,60,70,80-KMS2
12	A90B7-10600	制动钢管F Brake pipe	1	
13	GB/T882	销B10×28 Pin	2	
14	GB/T97.1	平垫10 Washer	2	
15	GB/T91	开口销2.5×28 Pin	2	
16	GJT-200-00	直角接头 Elbow	1	FD50,60,70,80-YC2
-	GJT-381-00	直角接头 Elbow	1	FD50,60,70,80-KMS2
17	A90B7-10700	制动泵总成 Brake pump ass'y	1	
18	GJT-156-00	直角接头 Elbow	1	
19	A90B7-10800	弯头钢管 Elbow Pipe	1	
20	GB/T5783	螺栓M12×20 Bolt	4	

行车制动管路系统
Brake Piping System

FD50,60,70,80-YC2/KMS2

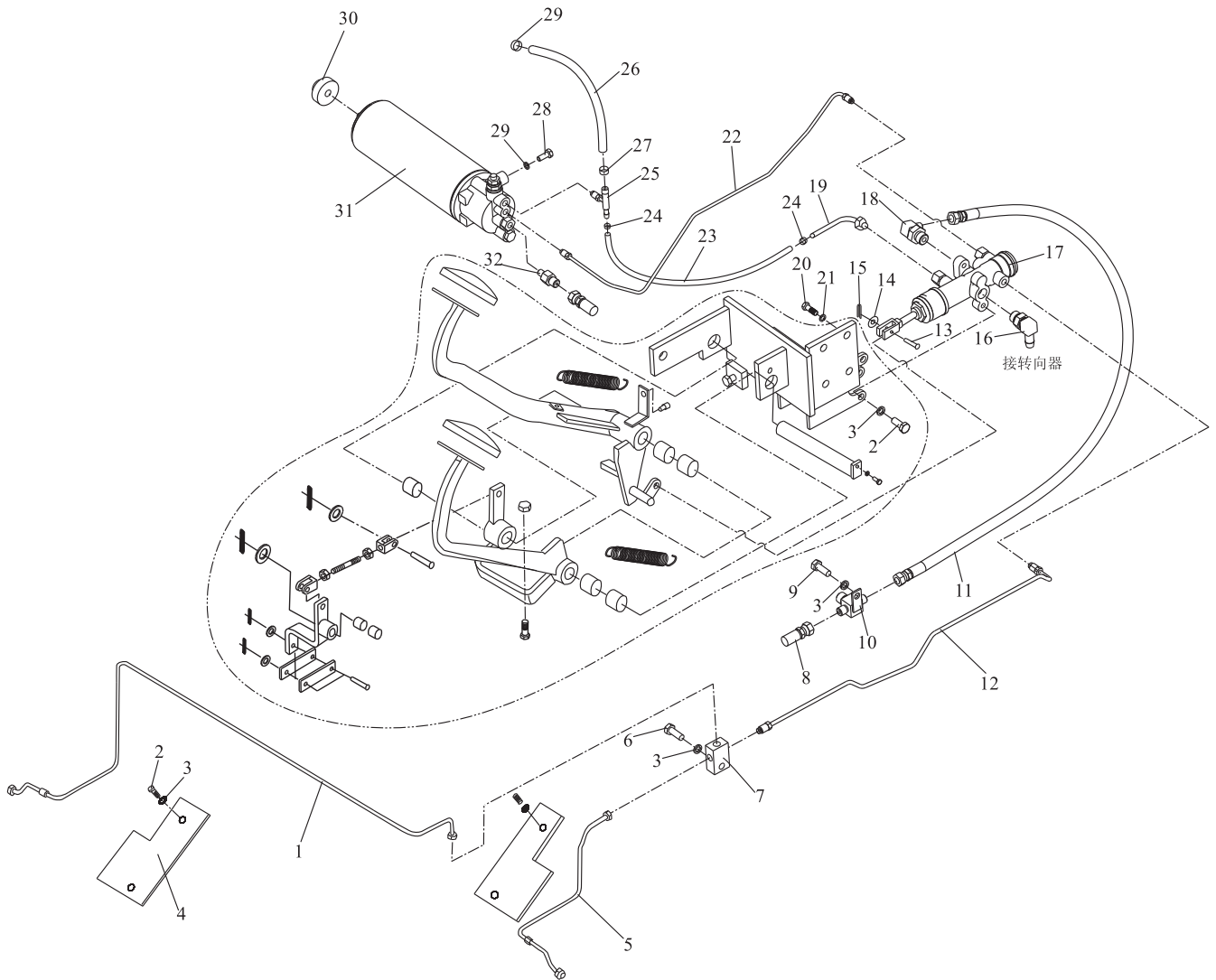

行车制动管路系统
Brake Piping System

FD50,60,70,80-YC2/KMS2

序号 Item	零件号 Part No	零部件名称 Description	数量 Q'ty	备注 Remark
21	GB/T93	弹垫12 Washer, lock	4	
22	A70A7-10100	制动钢管 Brake pipe	1	
23	TG000-06050	低压胶管 $\phi 6 \times 500$ Hose L.P.	1	
24	TK000-10016	卡箍 $\phi 10 \sim \phi 16$ Clip	2	
25	A90B7-11100	三通钢管 Three steel	1	
26	TG000-10100	低压胶管 $\phi 10 \times 1000$ Hose L.P.	1	
27	GB/T5783	卡箍 $\phi 13 \sim \phi 19$ Clip	2	
28	TK000-13019	螺栓M8 \times 20 Bolt	2	
29	GB/T93	弹垫8 Washer, lock	2	
30	A30A5-40003	橡胶垫 I Rubber	1	
31	A90B7-11200	蓄能器总成 Reserve ass'y	1	
32	GJT-159-00	直角接头 Elbow	1	

停车制动
Brake lever

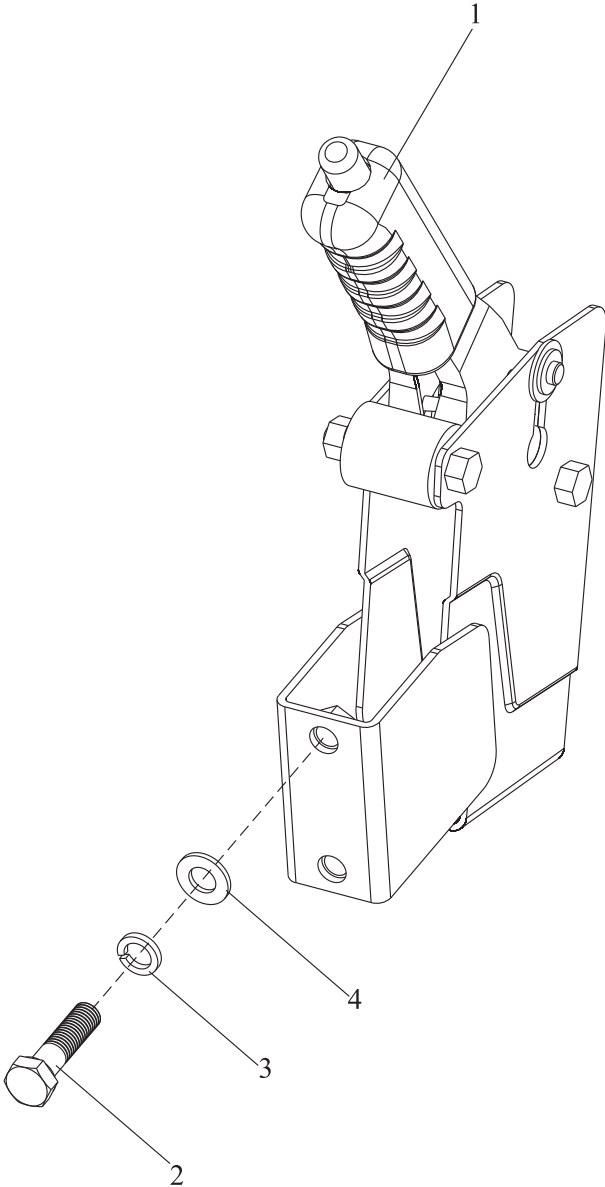

停车制动
Brake lever

序号 Item	零件号 Part No	零部件名称 Description	数量 Q'ty	备注 Remark
1	A50A7-20300	按钮式手制动 Push button hand brake	1	
2	GB/T5783	螺栓M10×35 Bolt	2	
3	GB/T93	弹垫10 Washer, lock	2	
4	GB/T97. 1	平垫10 Washer	2	

六、车身系统

BODY SYSTEM

车架与平衡重
Frame & counter weight

FD50,60,70,80-CY1/W3/S3
FY50,60,70,80-G3/G4

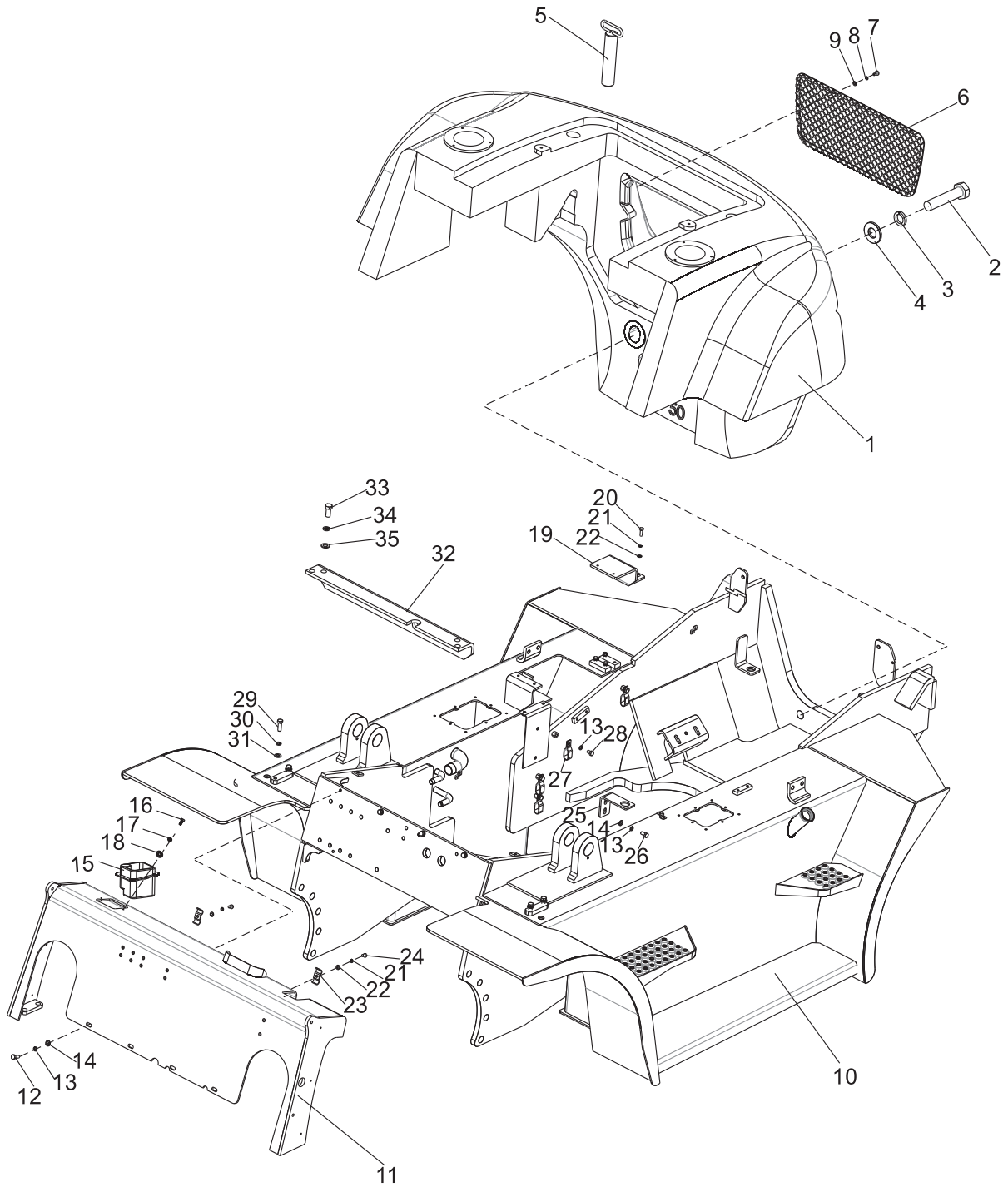

车架与平衡重
Frame & counter weight

FD50,60,70,80-CY1/W3/S3
FY50,60,70,80-G3/G4

序号 Item	零件号 Part No	零部件名称 Description	数量 Q'ty	备注 Remark
1	D50C1-50001	平衡重 Balance	1	5t车选用
-	D60C1-50001	平衡重 Balance	1	6t车选用
-	D70C1-50001	平衡重 Balance	1	7t车选用
-	D80C1-50001	平衡重 Balance	1	8t车选用
2	GB/T5783	螺栓M36×180 Bolt	2	5t,6t车选用
-	GB/T5783	螺栓M36×250 Bolt	2	7t,8t车选用
3	GB/T93	弹垫36 Washer,lock	2	
4	D30C1-50004	加厚垫圈 Washer	2	
5	D50C1-50100	牵引销 Pin	1	
6	D50C1-50006	配重护网 Net weight	1	
7	GB/T818	十字盘头螺钉M8×16 Screw	2	
8	GB/T93	弹垫8 Washer,lock	2	
9	GB/T97.1	平垫8 Washer	2	
10	D50C1-10100	车架体 Frame	1	FD50,60,70,80-CY1/W3
-	D50E1-10100	车架体 Frame	1	FD50,60,70,80-S3
-	D50F1-10100	车架体 Frame	1	FY50,60,70,80-G3
-	D50I1-10100	车架体 Frame	1	FY50,60,70,80-G4
11	D50C1-10700	仪表架总成 Cabinet	1	标准车选用
-	D50C1-11000	仪表架总成 Cabinet	1	欧标车选用
-	D50C1-12000	仪表架总成 Cabinet	1	手液车选用
-	D50C1-13000	仪表架总成 Cabinet	1	装驾驶室选用
12	GB/T5783	螺栓M10×25 Bolt	4	
13	GB/T93	弹垫10 Washer,lock	16	
14	GB/T97.1	平垫10 Washer	6	
15	D30C1-10001	工具箱 Box	1	

车架与平衡重
Frame & counter weight

FD50,60,70,80-CY1/W3/S3
FY50,60,70,80-G3/G4

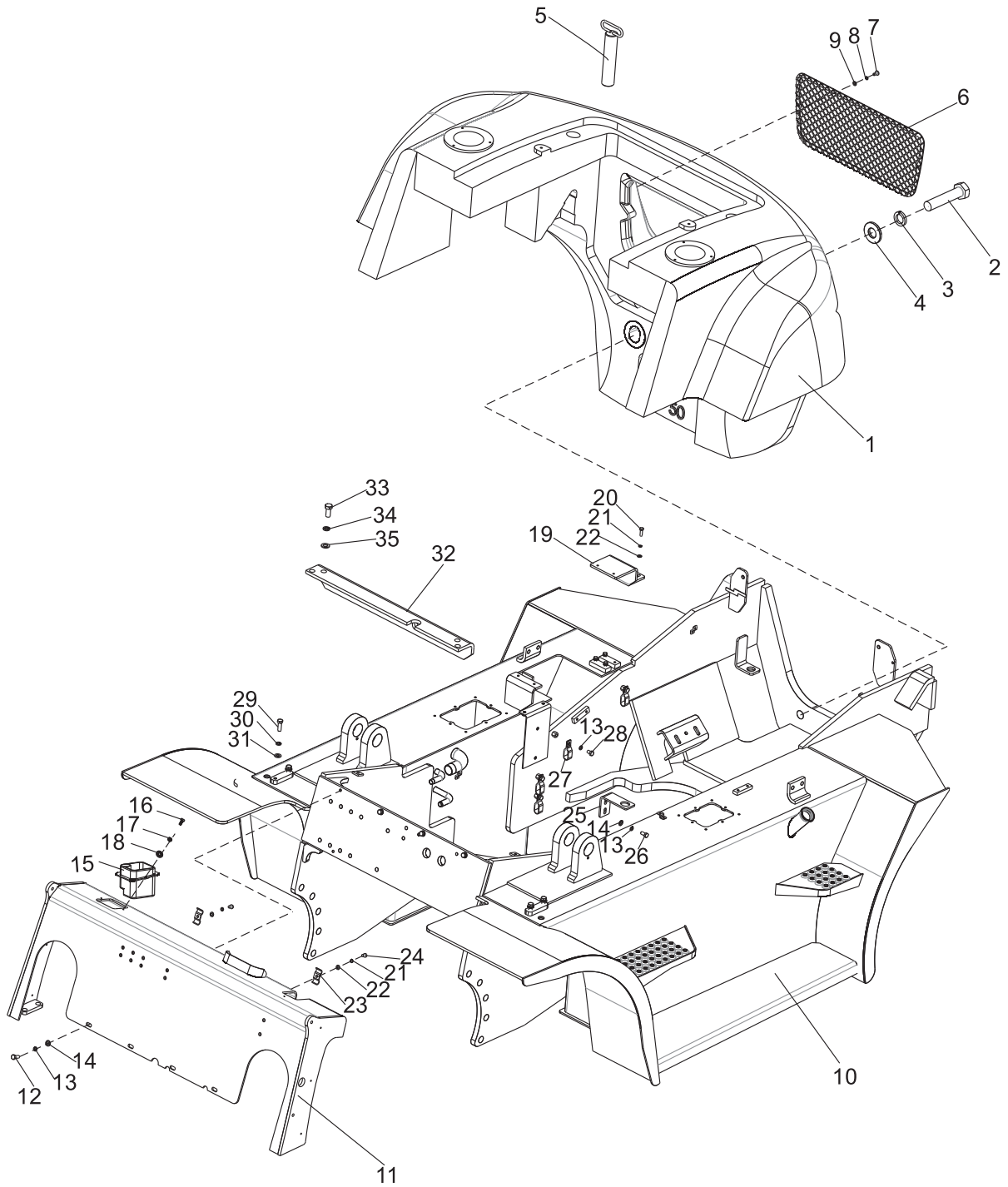

车架与平衡重
Frame & counter weight

FD50,60,70,80-CY1/W3/S3
FY50,60,70,80-G3/G4

序号 Item	零件号 Part No	零部件名称 Description	数量 Q'ty	备注 Remark
16	GB/T818	螺钉M6×16 Screw	2	
17	GB/T93	弹垫6 Washer,lock	2	
18	GB/T97.1	平垫6 Washer	2	
19	D50C1-10001	蓄电池支座II Battery support	1	
20	GB/T5783	螺栓M8×25 Bolt	4	
21	GB/T93	弹垫8 Washer,lock	6	
22	GB/T97.1	平垫8 Washer	6	
23	D50A1-10002	管夹 Clip	2	
24	GB/T5783	螺栓M8×12 Bolt	2	
25	D50A1-10613	消声器下支架 Bracket	1	
26	GB/T5783	螺栓M10×20 Bolt	2	
27	D30A1-10008	管夹5 Clip	10	
28	GB/T5783	螺栓M10×15 Bolt	10	
29	GB/T5783	螺栓M12×35 Bolt	4	
30	GB/T93	弹垫12 Washer,lock	4	
31	GB/T97.1	平垫12 Washer	4	
32	D90C1-10601	蓄能器支架 Bracket	1	
33	GB/T5783	螺栓M16×35 Bolt	4	
34	GB/T93	弹垫16 Washer,lock	4	
35	GB/T97.1	平垫16 Washer	4	

车架与平衡重

Frame & counter weight

FD50,60,70,80-YC2

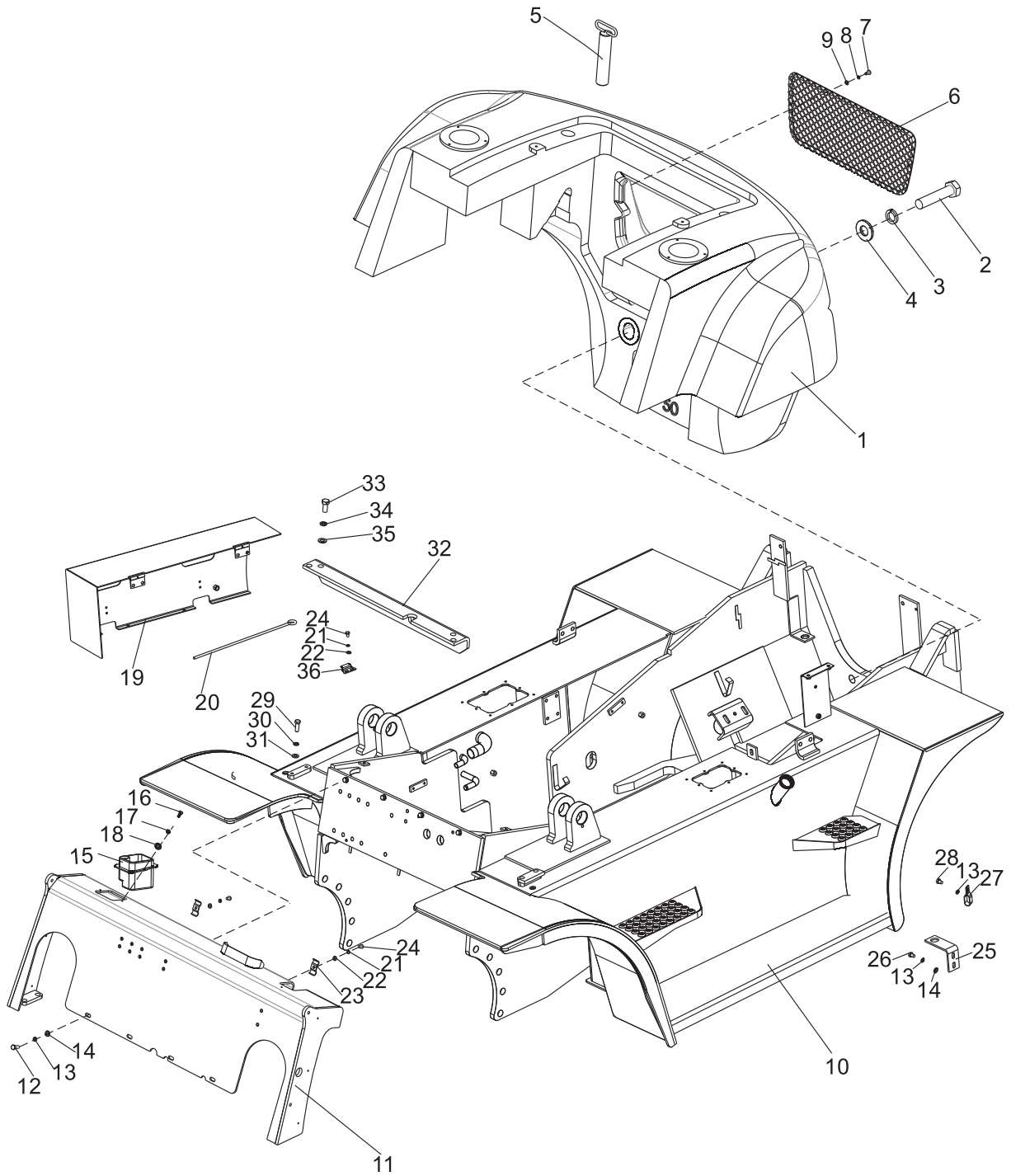

车架与平衡重

Frame & counter weight

FD50,60,70,80-YC2

序号 Item	零件号 Part No	零部件名称 Description	数量 Q'ty	备注 Remark
1	D50C1-50001	平衡重 Balance	1	5t车选用
-	D60C1-50001	平衡重 Balance	1	6t车选用
-	D70C1-50001	平衡重 Balance	1	7t车选用
-	D80C1-50001	平衡重 Balance	1	8t车选用
2	GB/T5783	螺栓M36×180 Bolt	2	5t,6t车选用
-	GB/T5783	螺栓M36×250 Bolt	2	7t,8t车选用
3	GB/T93	弹垫36 Washer,lock	2	
4	D30C1-50004	加厚垫圈 Washer	2	
5	D50C1-50100	牵引销 Pin	1	
6	D50C1-50006	配重护网 Net weight	1	
7	GB/T818	十字盘头螺钉M8×16 Screw	2	
8	GB/T93	弹垫8 Washer,lock	2	
9	GB/T97.1	平垫8 Washer	2	
10	D50G1-10100	车架体 Frame	1	
11	D50C1-10700	仪表架总成 Cabinet	1	标准车选用
-	D50C1-11000	仪表架总成 Cabinet	1	欧标车选用
-	D50C1-12000	仪表架总成 Cabinet	1	手液车选用
-	D50C1-13000	仪表架总成 Cabinet	1	装驾驶室选用
12	GB/T5783	螺栓M10×25 Bolt	4	
13	GB/T93	弹垫10 Washer,lock	14	
14	GB/T97.1	平垫10 Washer	6	
15	D30C1-10001	工具箱 Box	1	
16	GB/T818	螺钉M6×16 Screw	2	
17	GB/T93	弹垫6 Washer,lock	2	
18	GB/T97.1	平垫6 Washer	2	
19	D50G1-11100	电瓶盒盖总成 Battery cover	1	

车架与平衡重

Frame & counter weight

FD50,60,70,80-YC2

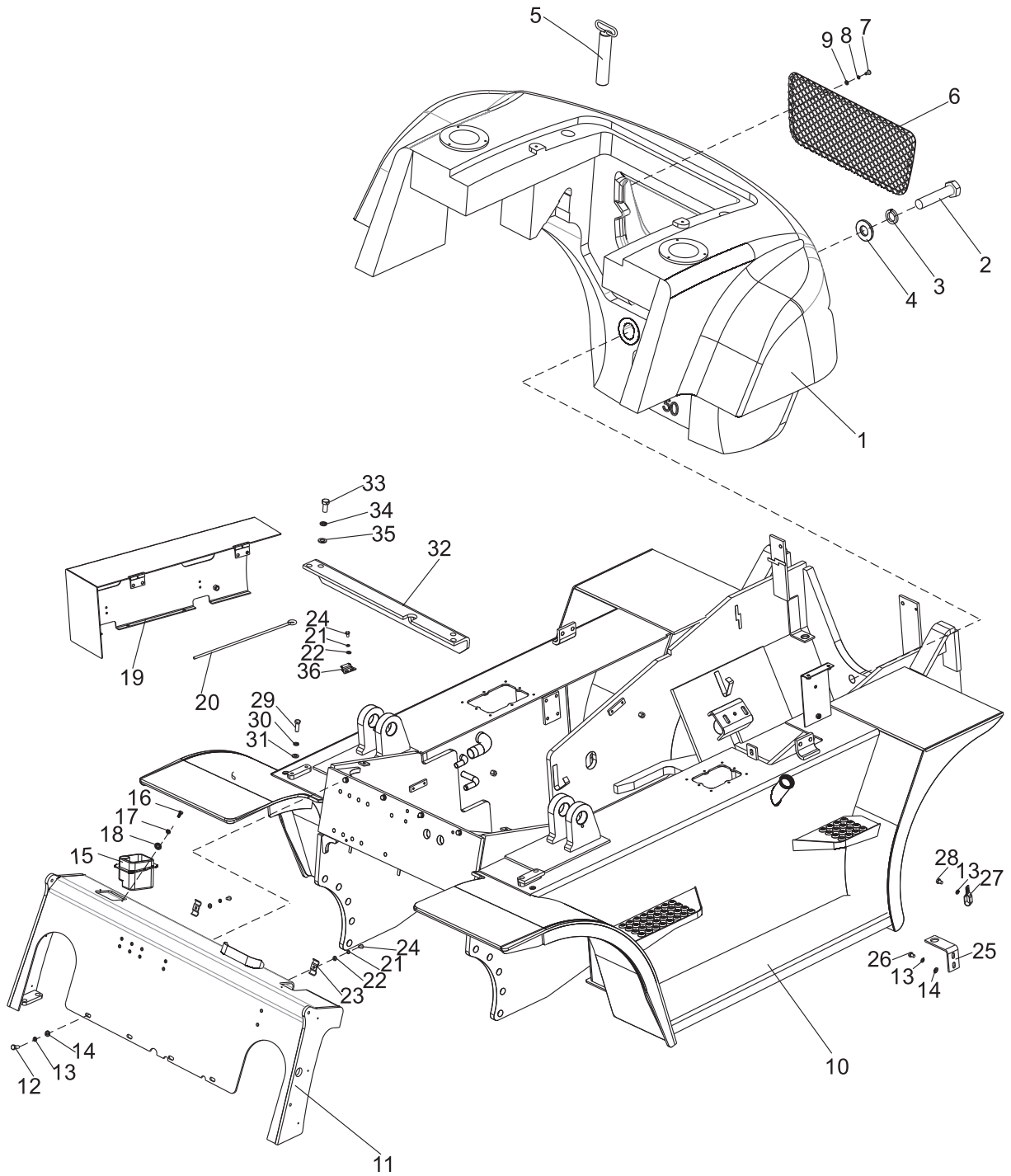

车架与平衡重

Frame & counter weight

FD50,60,70,80-YC2

序号 Item	零件号 Part No	零部件名称 Description	数量 Q'ty	备注 Remark
20	D50A1-10001	撑杆 Poles	1	
21	GB/T93	弹垫8 Washer,lock	6	
22	GB/T97.1	平垫8 Washer	6	
23	D50A1-10002	管夹 Clip	2	
24	GB/T5783	螺栓M8×12 Bolt	4	
25	D50A1-10613	消声器下支架 Bracket	1	
26	GB/T5783	螺栓M10×20 Bolt	2	
27	D30A1-10008	管夹5 Clip	8	
28	GB/T5783	螺栓M10×15 Bolt	8	
29	GB/T5783	螺栓M12×35 Bolt	4	
30	GB/T93	弹垫12 Washer,lock	4	
31	GB/T97.1	平垫12 Washer	4	
32	D90C1-10601	蓄能器支架 Bracket	1	
33	GB/T5783	螺栓M16×35 Bolt	4	
34	GB/T93	弹垫16 Washer,lock	4	
35	GB/T97.1	平垫16 Washer	4	
36	D15A1-20302	弹簧卡 Spring card	2	

车架与平衡重

Frame & counter weight

FD50,60,70,80-KMS2

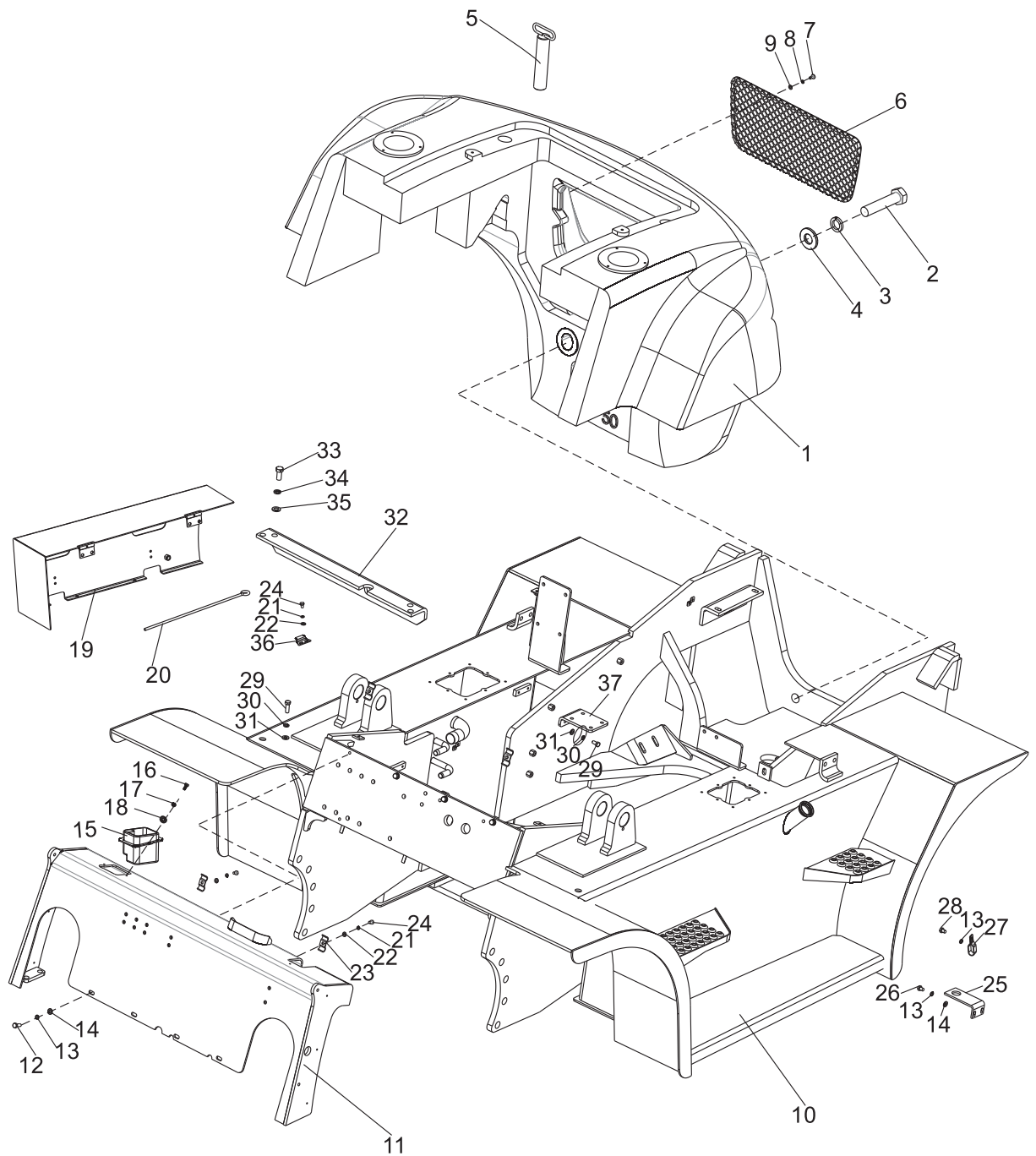

车架与平衡重

Frame & counter weight

FD50,60,70,80-KMS2

序号 Item	零件号 Part No	零部件名称 Description	数量 Q'ty	备注 Remark
1	D50C1-50001	平衡重 Balance	1	5t车选用
-	D60C1-50001	平衡重 Balance	1	6t车选用
-	D70C1-50001	平衡重 Balance	1	7t车选用
-	D80C1-50001	平衡重 Balance	1	8t车选用
2	GB/T5783	螺栓M36×180 Bolt	2	5t,6t车选用
-	GB/T5783	螺栓M36×250 Bolt	2	7t,8t车选用
3	GB/T93	弹垫36 Washer,lock	2	
4	D30C1-50004	加厚垫圈 Washer	2	
5	D50C1-50100	牵引销 Pin	1	
6	D50C1-50006	配重护网 Net weight	1	
7	GB/T818	十字盘头螺钉M8×16 Screw	2	
8	GB/T93	弹垫8 Washer,lock	2	
9	GB/T97.1	平垫8 Washer	2	
10	D50K1-10100	车架体 Frame	1	
11	D50C1-10700	仪表架总成 Cabinet	1	标准车选用
-	D50C1-11000	仪表架总成 Cabinet	1	欧标车选用
-	D50C1-12000	仪表架总成 Cabinet	1	手液车选用
-	D50C1-13000	仪表架总成 Cabinet	1	装驾驶室选用
12	GB/T5783	螺栓M10×25 Bolt	4	
13	GB/T93	弹垫10 Washer,lock	16	
14	GB/T97.1	平垫10 Washer	8	
15	D30C1-10001	工具箱 Box	1	
16	GB/T818	螺钉M6×16 Screw	2	
17	GB/T93	弹垫6 Washer,lock	2	
18	GB/T97.1	平垫6 Washer	2	
19	D50K1-10510	电瓶盒盖总成 Battery cover	1	

车架与平衡重
Frame & counter weight

FD50,60,70,80-KMS2

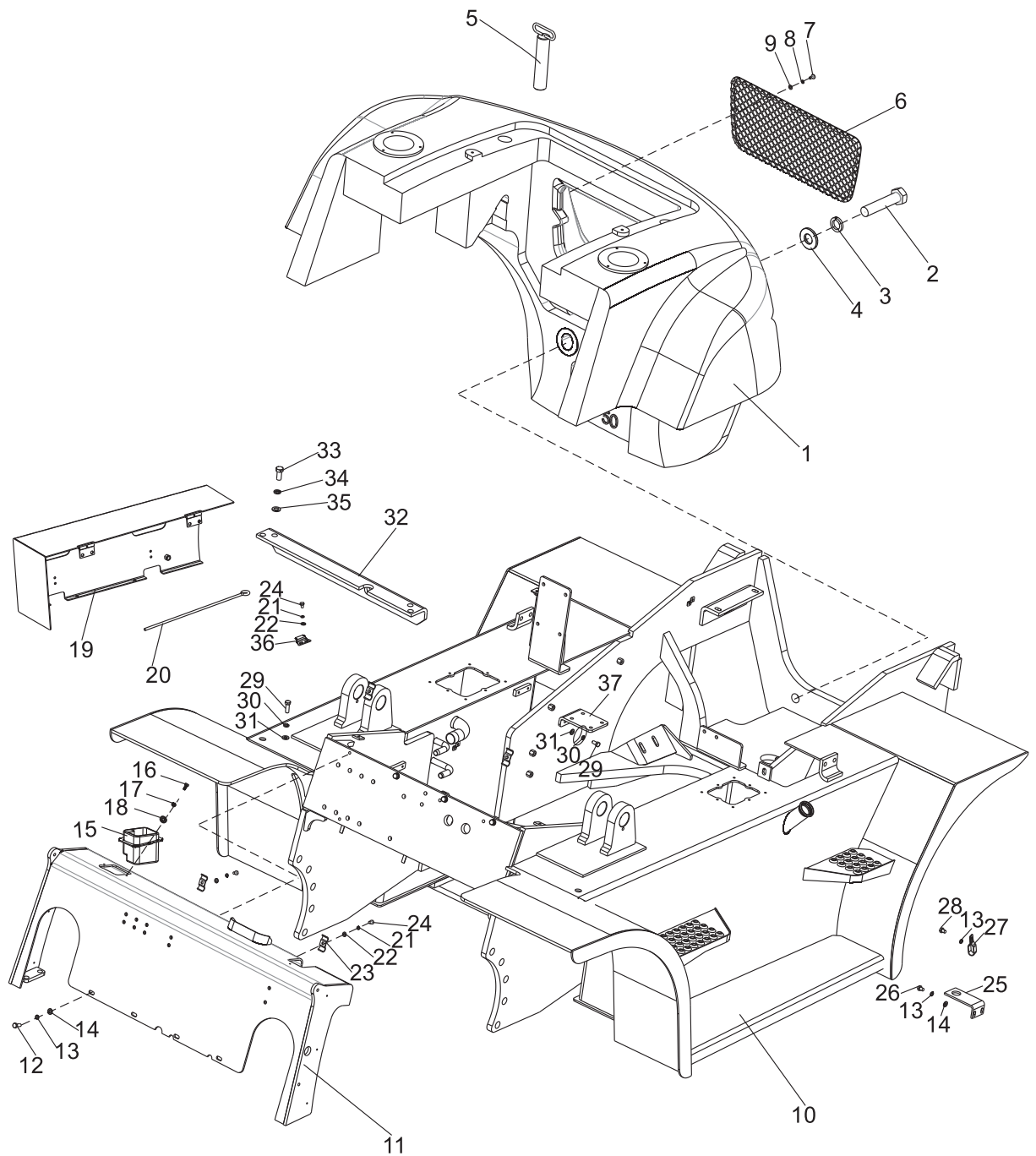

车架与平衡重

Frame & counter weight

FD50,60,70,80-KMS2

序号 Item	零件号 Part No	零部件名称 Description	数量 Q'ty	备注 Remark
20	D50A1-10001	撑杆 Poles	1	
21	GB/T93	弹垫8 Washer,lock	6	
22	GB/T97.1	平垫8 Washer	6	
23	D50A1-10002	管夹 Clip	2	
24	GB/T5783	螺栓M8×12 Bolt	4	
25	D50K1-10001	消声器下支架 Bracket	2	
26	GB/T5783	螺栓M10×20 Bolt	4	
27	D30A1-10008	管夹5 Clip	8	
28	GB/T5783	螺栓M10×15 Bolt	8	
29	GB/T5783	螺栓M12×35 Bolt	4	
30	GB/T93	弹垫12 Washer,lock	4	
31	GB/T97.1	平垫12 Washer	4	
32	D90C1-10601	蓄能器支架 Bracket	1	
33	GB/T5783	螺栓M16×35 Bolt	4	
34	GB/T93	弹垫16 Washer,lock	4	
35	GB/T97.1	平垫16 Washer	4	
36	D15A1-20302	弹簧卡 Spring card	2	
37	D50K1-10002	机油滤安装板 Oil filter installation plate	1	

机罩底板类及座椅 Hood, Floor Board & Seat

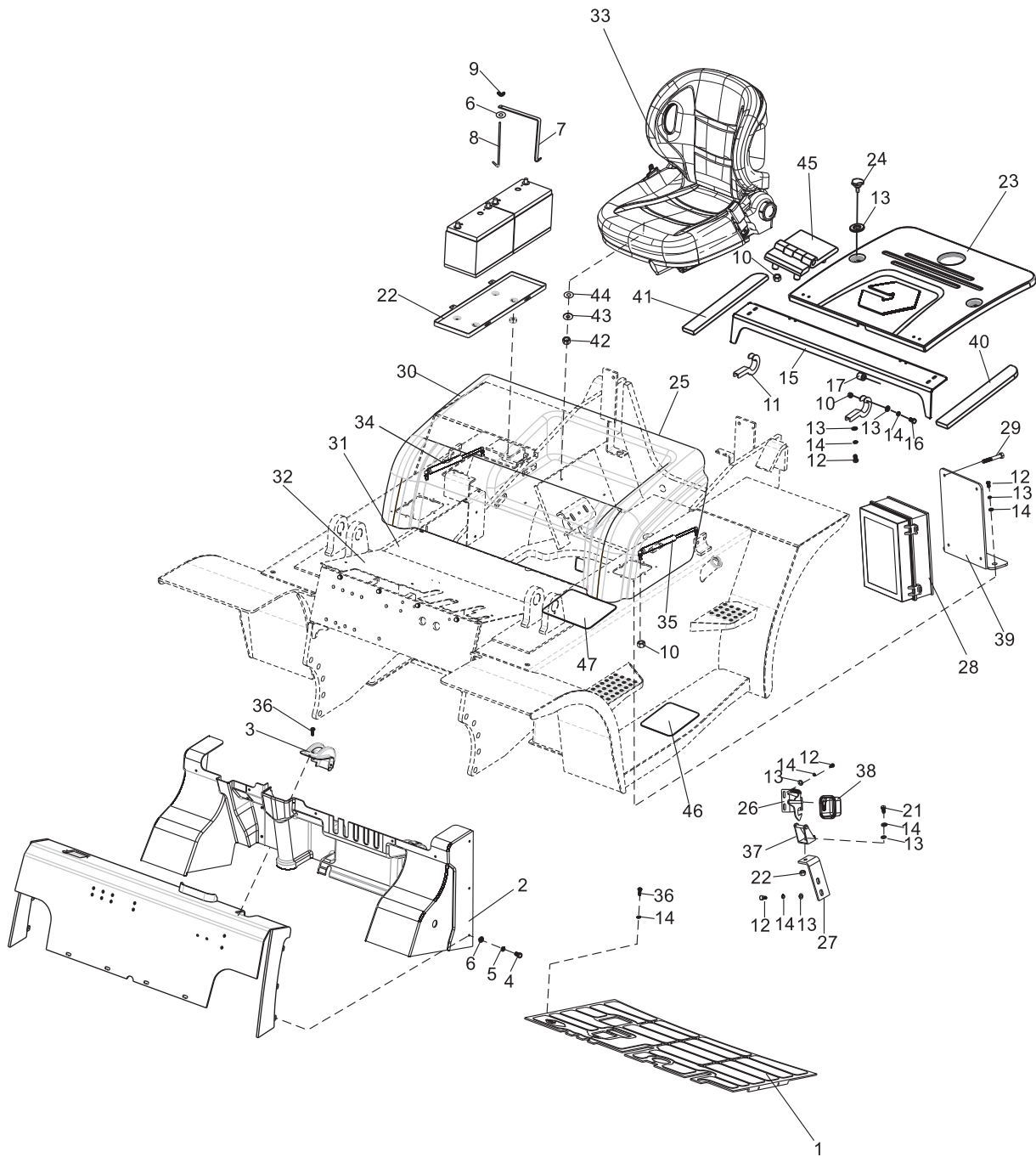

机罩底板类及座椅
Hood、Floor Board & Seat

序号 Item	零件号 Part No	零部件名称 Description	数量 Q'ty	备注 Remark
1	D50A1-20006	底板垫 Gasket	1	
2	D50C1-20010	覆盖件总成 Covering parts ass'y	1	
3	D50C1-20003	手制动覆盖件 Hand brake covering	1	
4	GB/T818	螺钉M6×16 Screw	2	
5	GB/T93	弹垫6 Washer,lock	2	
6	GB/T97.1	平垫6 Washer	4	FD/Y50,60,70,80-CY1 /W3/YC2/G3/G4
7	A45A2-00920	支架 Bracket	2	FD/Y50,60,70,80-CY1 /W3/YC2/G3/G4
8	A45A2-00930	螺杆 Screw	2	FD/Y50,60,70,80-CY1 /W3/YC2/G3/G4
9	GB/T62	蝶形螺母M6 Nut	2	FD/Y50,60,70,80-CY1 /W3/YC2/G3/G4
10	GB/T889.1	非金属嵌件锁紧螺母M8 Nut	14	
11	D50C1-20800	铰链 Hinge	2	
12	GB/T5783	螺栓M8×20 Bolt	11	
13	GB/T97.1	平垫8 Washer	16	
14	GB/T93	弹垫8 Washer,lock	16	
15	D50C1-20700	横梁总成 Beam	1	
16	A30A5-40005	螺栓 Bolt	2	
17	D30A1-20005	衬套 Bushing	2	
18	GB/T5786	螺栓M12×1.25×25 Bolt	4	
19	GB/T93	弹垫12 Washer,lock	4	
20	GB/T97.1	平垫12 Washer	4	
21	GB/T5783	螺栓M8×25 Bolt	1	
22	A45A2-09010	蓄电池底座 Battery base	1	FD/Y50,60,70,80-CY1 /W3/YC2/G3/G4
23	D50C1-20008	水箱盖板 Radiator cover	1	
24	D30A1-20009	螺钉 Screw	2	

机罩底板类及座椅 Hood、Floor Board & Seat

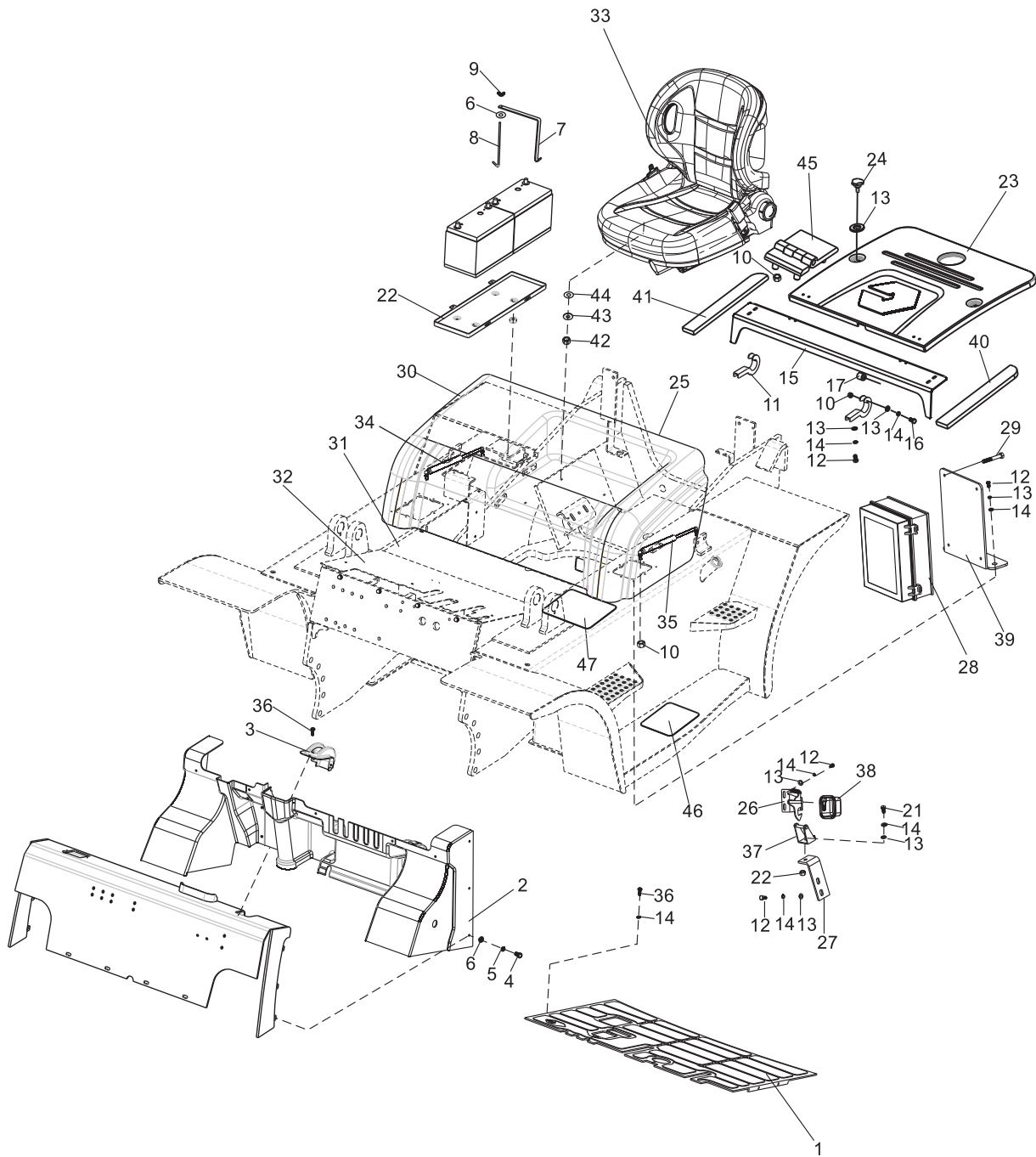

机罩底板类及座椅 Hood、Floor Board & Seat

序号 Item	零件号 Part No	零部件名称 Description	数量 Q'ty	备注 Remark
25	D30A1-20007×2000	密封条1×2000mm Gasket	1	
26	D30A1-20720	机罩上挂钩 Hook	1	
27	D50C1-20007	锁支架 Locks Support	1	
28	A50B2-01000	叉车中央电器盒 Panel	1	
29	GB/T818	螺钉M5×25 Screw	4	
30	D50C1-20100	内燃机罩总成 Bonnet ass'y	1	FD50,60,70,80-CY1 /W3/YC2/KMS2
-	D50E1-20100	内燃机罩总成 Bonnet ass'y	1	FD/Y50,60,70,80-S3 /G3/G4
31	D50C1-20500	后底板总成 Floor,board,rear	1	标准车选用
-	D50C1-20600	后底板总成 Floor,board,rear	1	装暖风机选用
32	D50A1-20800	前底板总成 Floor board,front	1	FD50,60,70,80-KMS2除外
-	D90F1-20100	前底板总成 Floor board,front	1	FD50,60,70,80-KMS2
33	A30A1-00100	BF2高配座椅 Seat	1	标配
-	A30A1-00500	BF2全悬浮高配座椅 Seat	1	选用
-	A30A1-00400	折叠座椅 Seat	1	选用
-	A30A1-00300	BF2电子开关高配座椅 Seat	1	OPS车选用
-	A30A1-00600	BF2全悬浮电子开关高配座椅 Seat	1	OPS车选用
-	A30A1-00800	BF5电子开关高配座椅 Seat	1	OPS车选用
-	A30A1-01000	BF5全悬浮电子开关高配座椅 Seat	1	OPS车选用
-	A30A1-00700	BF5高配座椅 Seat	1	CE车选用
-	A30A1-00900	BF5全悬浮高配座椅 Seat	1	CE车选用
34	D50C1-20400	气弹簧150N Shock,absorber	1	
35	D50C1-20300	气弹簧550N Shock,absorber	1	
36	GB/T818	螺钉M8×16 Screw	4	
37	D30A1-20710	机罩下挂钩 Hook	1	
38	D30A1-20701	挂钩盒 Hook box	1	

机罩底板类及座椅 Hood、Floor Board & Seat

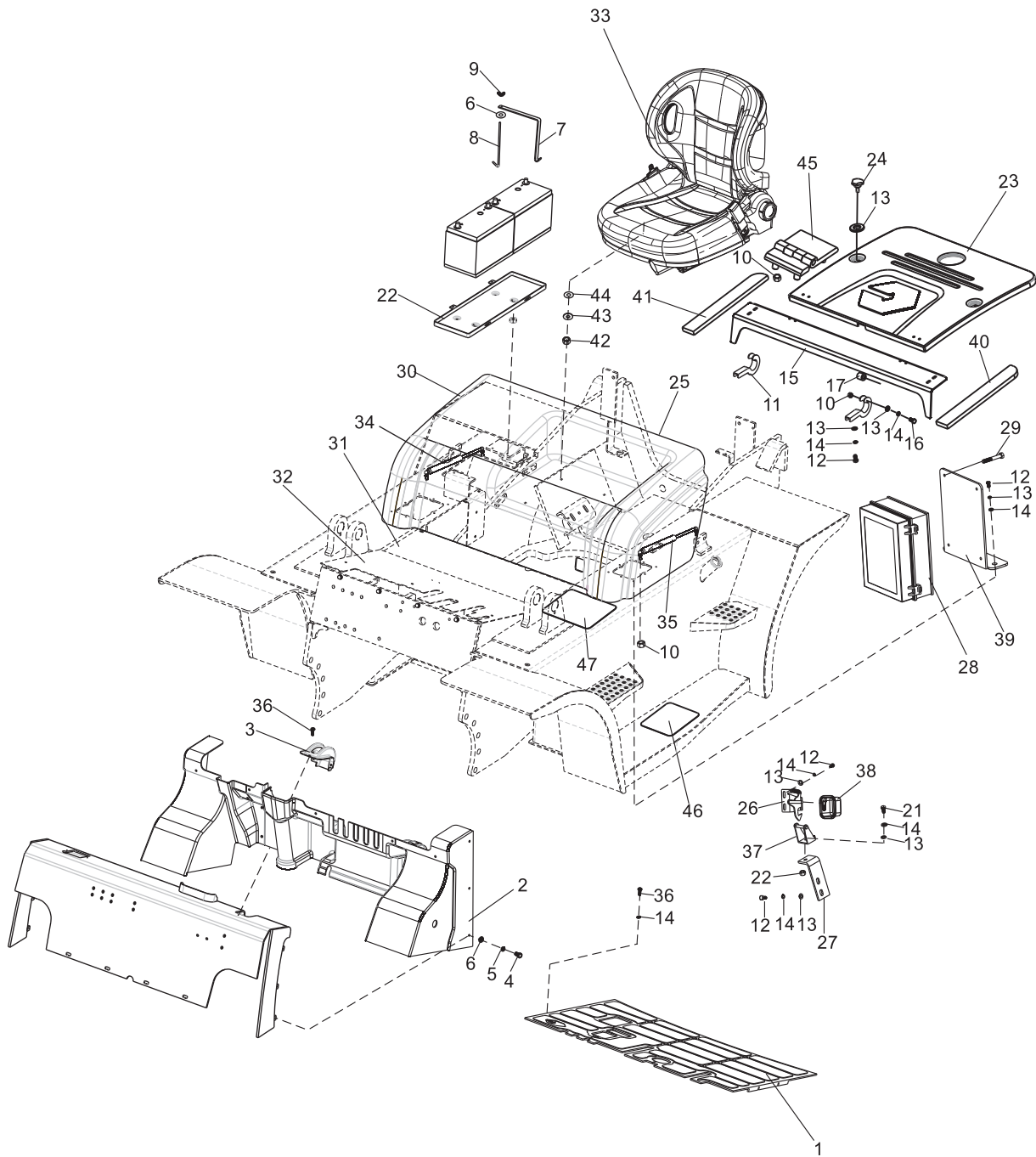

机罩底板类及座椅
Hood、Floor Board & Seat

序号 Item	零件号 Part No	零部件名称 Description	数量 Q'ty	备注 Remark
39	D50C1-20015	电器盒安装支架 Bracket	1	
40	D50C1-20009R	发泡胶条(右) Foaming adhesive tape	1	
41	D50C1-20009L	发泡胶条(左) Foaming adhesive tape	1	
42	GB/T6170	螺母M8 Nut	4	座椅附带
43	GB/T93	弹垫8 Washer,lock	4	座椅附带
44	GB/T97.1	平垫8 Washer	4	座椅附带
45	D45G1-20800	锌合金合页 Zinc alloy hinge	2	
46	D50C1-20006	防滑贴纸II Non-slip stickers II	2	
47	D50C1-20005	防滑贴纸I Non-slip stickers I	2	

护顶架
Head guard

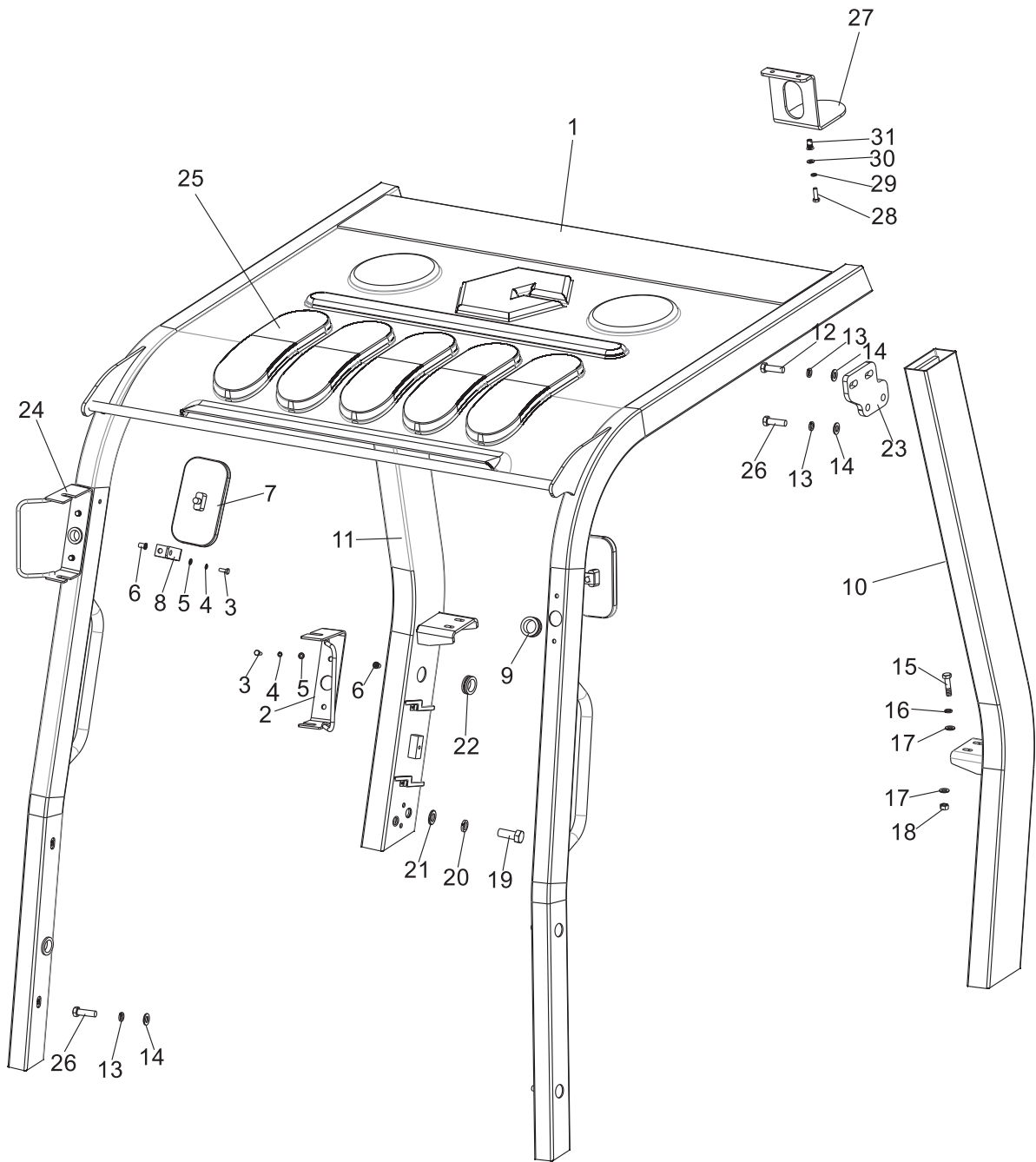

护顶架

Head guard

序号 Item	零件号 Part No	零部件名称 Description	数量 Q'ty	备注 Remark
1	D50C1-30200	框架总成 Overhead guard	1	
2	D30A1-30700L	前灯架总成(左) Guard,lamp F	1	
3	GB/T5783	螺栓M6×25 Bolt	6	
4	GB/T93	弹垫6 Washer,lock	6	
5	GB/T97.1	平垫6 Washer	6	
6	D30C1-30001	铆螺母 M6 Nut	6	
7	D30A1-30800	倒车镜 Back-mirror	2	
8	D30A1-30002	倒车镜支架 Guard	2	
9	D30A1-30004	出线胶圈I Grommet	2	
10	D50C1-30300	左后支撑 Rear pipe L.H.	1	
11	D50C1-30400	右后支撑 Rear pipe R.H.	1	
12	GB/T5783	螺栓M12×40 Bolt	4	
13	GB/T97.1	平垫12 Washer	12	
14	GB/T93	弹垫12 Washer,lock	12	
15	GB/T5783	螺栓M10×35 Bolt	4	
16	GB/T93	弹垫10 Washer,lock	4	
17	GB/T97.1	平垫10 Washer	8	
18	GB/T6170	螺母 M10 Nut	4	
19	GB//T5783	螺栓M16×40 Bolt	4	
20	GB/T97.1	平垫16 Washer	4	
21	GB/T93	弹垫16 Washer,lock	4	
22	D30A1-30005	出线胶圈II Grommet	3	
23	D50C1-30211	安装板 Mounting plate	2	
24	D30A1-30700R	前灯架总成(右) Guard,lamp F	1	

护顶架
Head guard

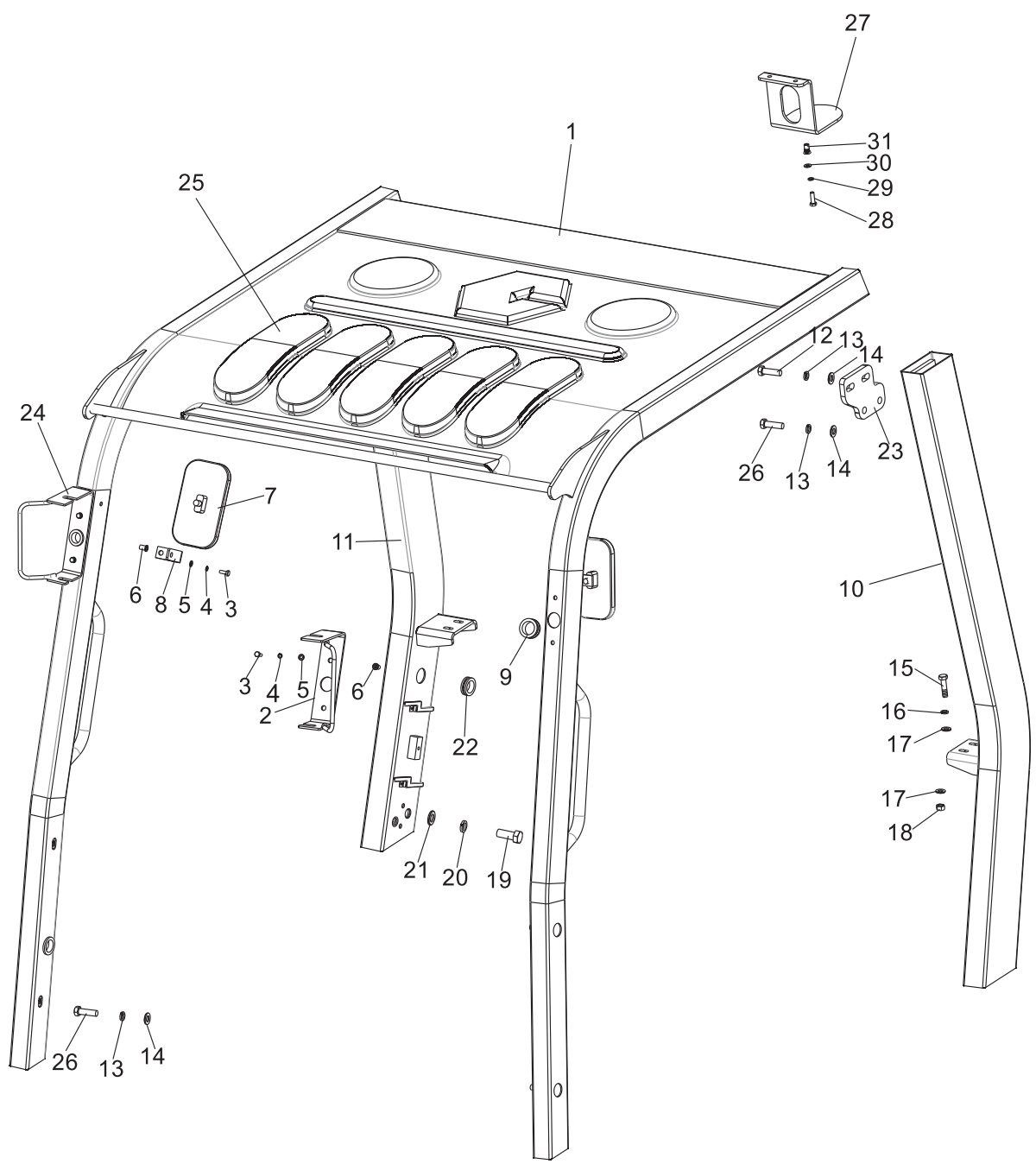

护顶架
Head guard

序号 Item	零件号 Part No	零部件名称 Description	数量 Q'ty	备注 Remark
25	D30C1-30002	防雨罩 Rain cover	5	
26	GB/T5783	螺栓M12×30 Bolt	8	
27	D30C1-30005	警灯固定架 Alarm lamp anchor	1	加警灯选配
28	GB/T5783	螺栓M8×25 Bolt	2	加警灯选配
29	GB/T93	弹垫8Washer,lock	2	加警灯选配
30	GB/T97.1	平垫8 Washer	2	加警灯选配
31	D35G1-30001	铆螺母 M8 Nut	2	加警灯选配

七、液压系统

HYDRAULIC SYSTEM

液压油箱
Oil tank

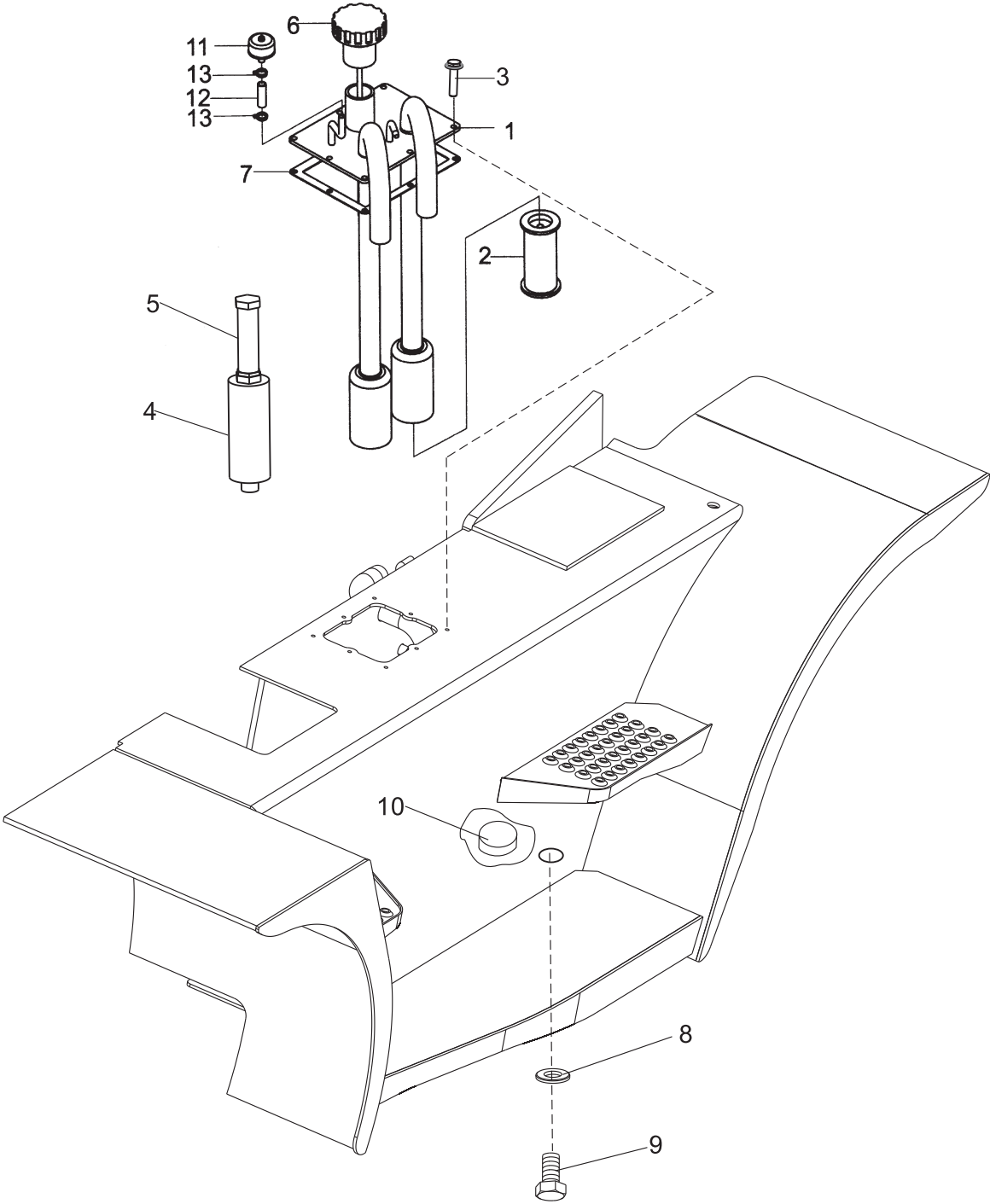

液压油箱
Oil tank

序号 Item	零件号 Part No	零部件名称 Description	数量 Q'ty	备注 Remark
1	A50C4-50100	盖板总成 Coverplate ass'y	1	
2	A30A4-50400	吸油滤油器 Strainer	2	
3	GB/T5787	六角法兰面螺栓M8×16 Bolt	8	
4	A45A4-50400	回油滤清器 Strainer	1	
5	A45A4-50200	钢管总成 Steel pipe	1	
6	A50A4-50100	加油盖总成 Oil cap ass'y	1	
7	A50A4-50001	盖板垫 Cover gasket	1	
8	A30A4-50004	ED密封圈26 Washer	1	
9	A30A4-50002	放油螺塞 Plug,drain	1	
10	A30A4-50003	磁铁 Magnet	2	
11	A30A4-50500	呼吸器 Breath setting	1	
12	TG000-10007	耐油胶管Φ10×70 Hose	1	
13	TK000-13019	卡箍Φ13-19 Clip	2	

阀操纵总成 (二片)
Valve control (two-throw)

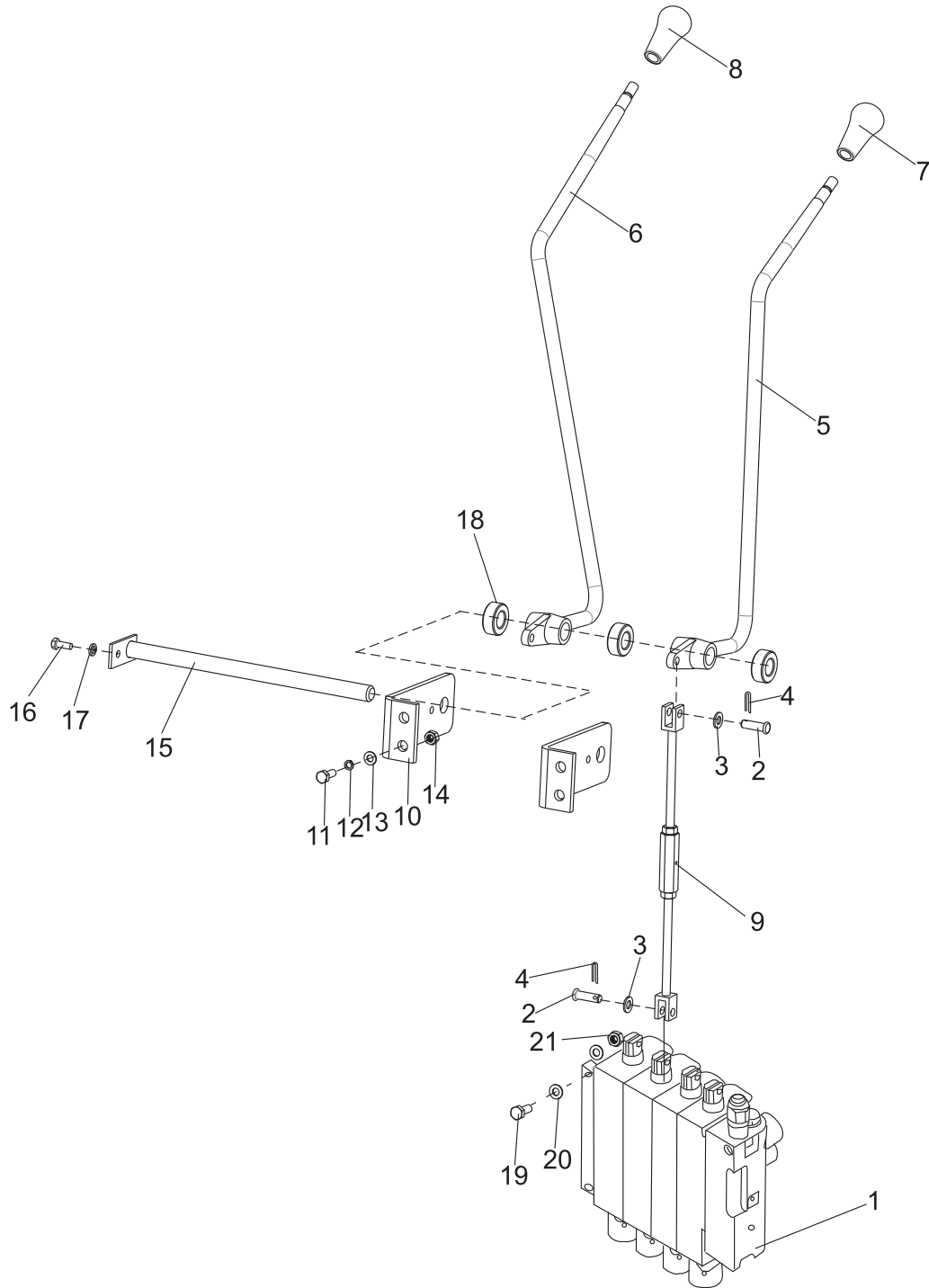

阀操纵总成 (二片)
Valve control (two-throw)

序号 Item	零件号 Part No	零部件名称 Description	数量 Q'ty	备注 Remark
1	A50A4-30000*2	多路阀 Control ass'y	1	标准车用
-	A50B4-30000*2	多路阀 Control ass'y	1	欧标车用
2	A50A7-40002	销轴 $\phi 8 \times 26$ Pin	4	
3	GB/T91	开口销 $\phi 2.5 \times 20$ Pin, cotter	4	
4	GB/T97.1	平垫8 Washer	4	
5	A50A7-40410	升降操纵杆 Lever, lift	1	
6	A50A7-40420	倾斜操纵杆 Lever, tilt	1	
7	A30A7-40003	起升手柄 Knob, lift	1	
8	A30A7-40004	倾斜手柄 Knob, tilt	1	
9	A50A7-40300	连接杆 Joint	2	
10	A50A7-40200	阀杆支架 Bracket, valve lever	2	
11	GB/T5783	螺栓 $M10 \times 25$ Bolt	4	
12	GB/T97.1	平垫10 Washer	4	
13	GB/T93	弹垫10 Washer, lock	4	
14	GB/T6170	螺母10 Nut	4	
15	A50A7-40100	连接轴 Shaft, valve	1	
16	GB/T5783	螺栓 $M6 \times 10$ Bolt	1	
17	GB/T93	弹垫6 Washer, lock	1	
18	A50A7-40001	调节套 Bushing	3	
19	GB/T5782	螺栓 $M12 \times 60 \times 35$ Bolt	4	
20	GB/T97.1	平垫12 Washer	8	
21	GB/T889.1	锁紧螺母12 Nut	4	

阀操纵总成 (三片)
Valve control (three-throw)

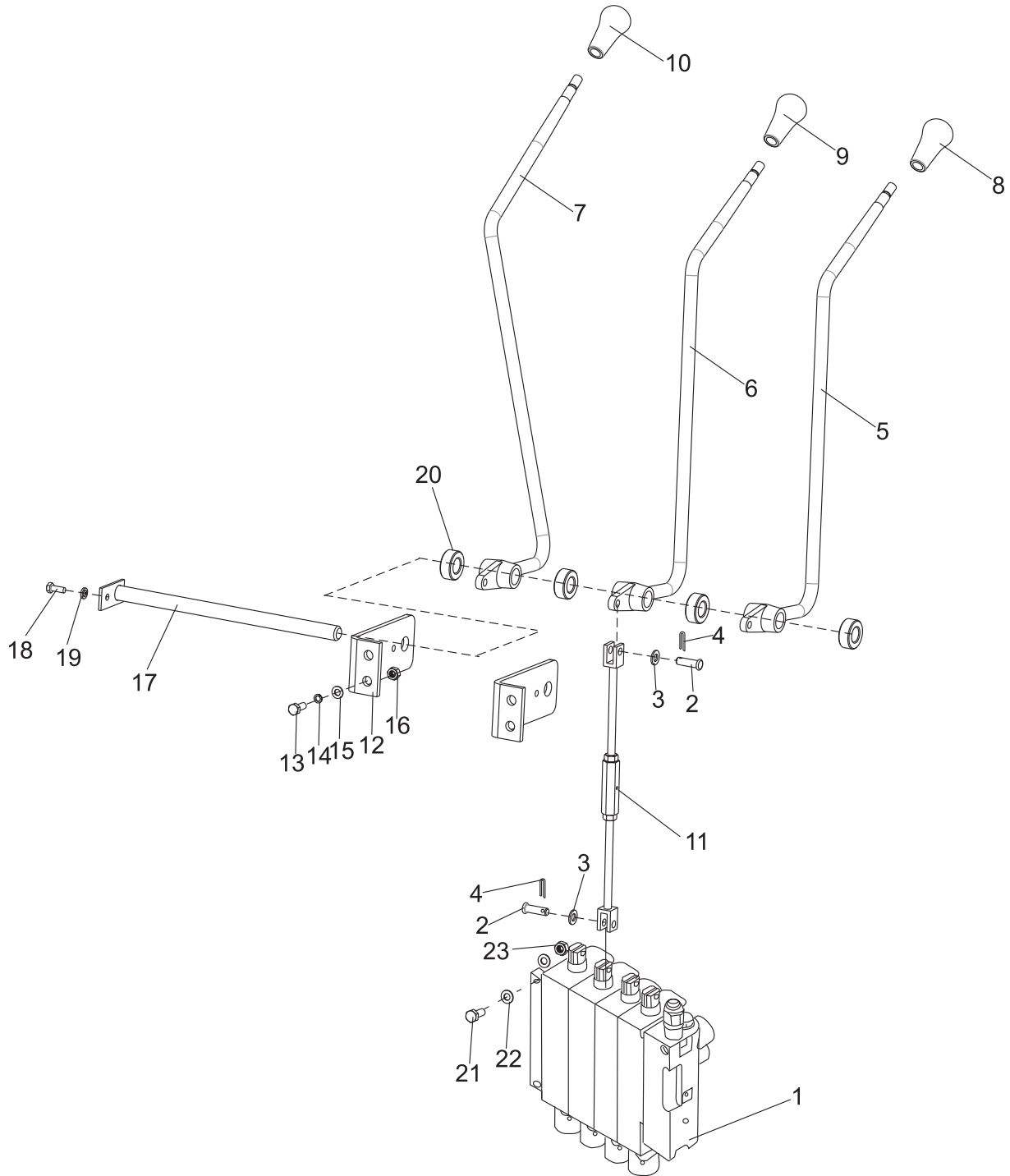

阀操纵总成 (三片)
Valve control (three-throw)

序号	零件号	零部件名称	数量	备注
1	A50A4-30000*3	多路阀 Control ass'y	1	标准车用
-	A50B4-30000*3	多路阀 Control ass'y	1	欧标车用
2	A50A7-40002	销轴 $\phi 8 \times 26$ Pin	6	
3	GB/T91	开口销 $\phi 2.5 \times 20$ Pin, cotter	6	
4	GB/T97.1	平垫8 Washer	6	
5	A50A7-40410	升降操纵杆 Lever, lift	1	
6	A50A7-40420	倾斜操纵杆 Lever, tilt	1	
7	A50A7-40430	第三片阀操纵杆 Lever,third	1	
8	A30A7-40003	起升手柄 Knob, lift	1	
9	A30A7-40004	倾斜手柄 Knob, tilt	1	
10	A30A7-40005	侧移手柄 Knob, sidesway	1	
11	A50A7-40300	连接杆 Joint	3	
12	A50A7-40200	阀杆支架 Bracket, valve lever	2	
13	GB/T5783	螺栓M10 \times 25 Bolt	4	
14	GB/T97.1	平垫10 Washer	4	
15	GB/T93	弹垫10 Washer, lock	4	
16	GB/T6170	螺母10 Nut	4	
17	A50A7-40100	连接轴 Shaft, valve	1	
18	GB/T5783	螺栓M6 \times 10 Bolt	1	
19	GB/T93	弹垫6 Washer, lock	1	
20	A50A7-40001	调节套 Bushing	4	
21	GB/T5782	螺栓M12 \times 60 \times 35 Bolt	4	
22	GB/T97.1	平垫12 Washer	8	
23	GB/T889.1	锁紧螺母12 Nut	4	

阀操纵总成 (四片)
Valve control (four-throw)

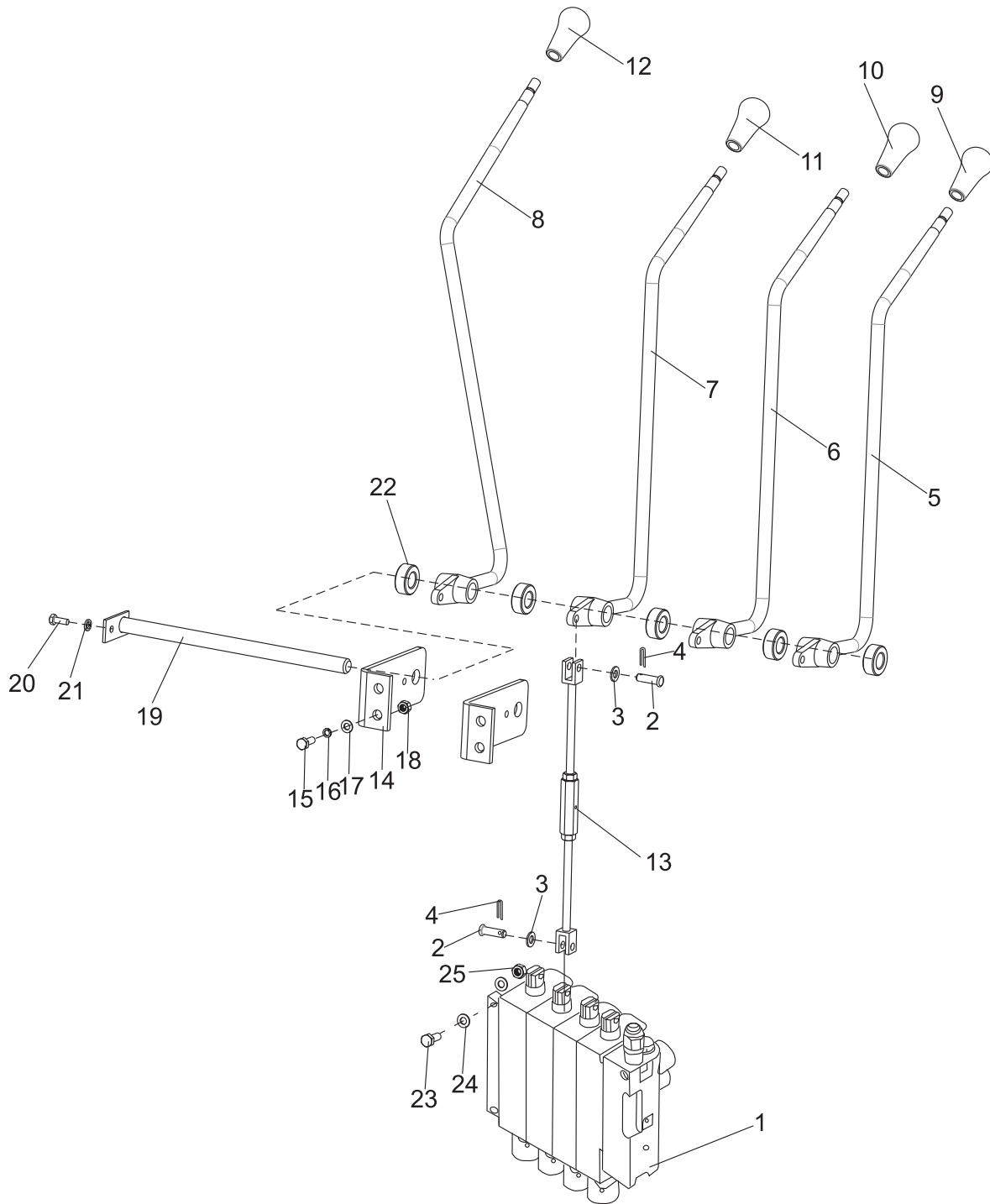

阀操纵总成 (四片)

Valve control (four-throw)

序号 Item	零件号 Part No	零部件名称 Description	数量 Q'ty	备注 Remark
1	A50A4-30000*4	多路阀 Control ass'y	1	标准车用
-	A50B4-30000*4	多路阀 Control ass'y	1	欧标车用
2	A50A7-40002	销轴 $\phi 8 \times 26$ Pin	8	
3	GB/T91	开口销 $\phi 2.5 \times 20$ Pin, cotter	8	
4	GB/T97.1	平垫8 Washer	8	
5	A50A7-40410	升降操纵杆 Lever, lift	1	
6	A50A7-40420	倾斜操纵杆 Lever, tilt	1	
7	A50A7-40430	第三片阀操纵杆 Lever,third	1	
8	A50A7-40440	第四片阀操纵杆 Lever,fourth	1	
9	A30A7-40003	起升手柄 Knob, lift	1	
10	A30A7-40004	倾斜手柄 Knob, tilt	1	
11	A30A7-40005	侧移手柄 Knob, sidesway	1	
12	A30A7-40006	夹紧手柄 Knob, clamp	1	
13	A50A7-40300	连接杆 Joint	4	
14	A50A7-40200	阀杆支架 Bracket, valve lever	2	
15	GB/T5783	螺栓 $M10 \times 25$ Bolt	4	
16	GB/T97.1	平垫10 Washer	4	
17	GB/T93	弹垫10 Washer, lock	4	
18	GB/T6170	螺母10 Nut	4	
19	A50A7-40100	连接轴 Shaft, valve	1	
20	GB/T5783	螺栓 $M6 \times 10$ Bolt	1	
21	GB/T93	弹垫6 Washer, lock	1	
22	A50A7-40001	调节套 Bushing	5	
23	GB/T5782	螺栓 $M12 \times 60 \times 35$ Bolt	4	
24	GB/T97.1	平垫12 Washer	8	
25	GB/T889.1	锁紧螺母12 Nut	4	

阀操纵总成 (五片) Valve control (five-throw)

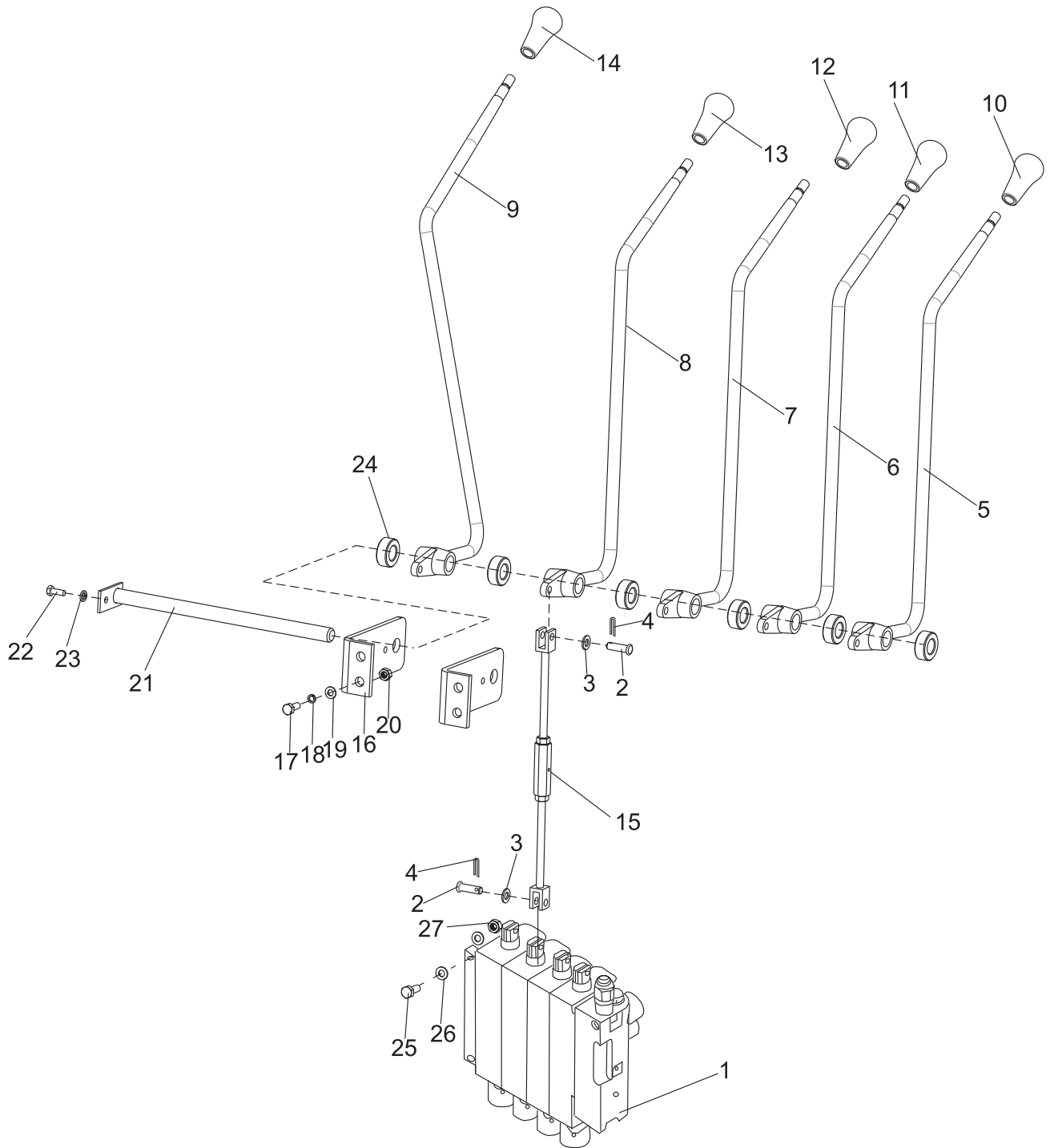

阀操纵总成 (五片)
Valve control (five-throw)

序号 Item	零件号 Part No	零部件名称 Description	数量 Q'ty	备注 Remark
1	A50A4-30000*4	多路阀 Control ass'y	1	标准车用
-	A50B4-30000*4	多路阀 Control ass'y	1	欧标车用
2	A50A7-40002	销轴 $\phi 8 \times 26$ Pin	10	
3	GB/T91	开口销 $\phi 2.5 \times 20$ Pin, cotter	10	
4	GB/T97.1	平垫8 Washer	10	
5	A50A7-40410	升降操纵杆 Lever, lift	1	
6	A50A7-40420	倾斜操纵杆 Lever, tilt	1	
7	A50A7-40430	第三片阀操纵杆 Lever,third	1	
8	A50A7-40440	第四片阀操纵杆 Lever,fourth	1	
9	A50A7-40450	第五片阀操纵杆 Lever,fifth	1	
10	A30A7-40003	起升手柄 Knob, lift	1	
11	A30A7-40004	倾斜手柄 Knob, tilt	1	
12	A30A7-40005	侧移手柄 Knob, sidesway	1	
13	A30A7-40006	夹紧手柄 Knob, clamp	1	
14	A30A7-40007	旋转手柄 Knob, rotate	1	
15	A50A7-40300	连接杆 Joint	5	
16	A50A7-40200	阀杆支架 Bracket, valve lever	2	
17	GB/T5783	螺栓M10 \times 25 Bolt	4	
18	GB/T97.1	平垫10 Washer	4	
19	GB/T93	弹垫10 Washer ,lock	4	
20	GB/T6170	螺母10 Nut	4	
21	A50A7-40100	连接轴 Shaft, valve	1	
22	GB/T5783	螺栓M6 \times 10 Bolt	1	
23	GB/T93	弹垫6 Washer,lock	1	
24	A50A7-40001	调节套 Bushing	6	
25	GB/T5782	螺栓M12 \times 60 \times 35 Bolt	4	
26	GB/T97.1	平垫12 Washer	8	
27	GB/T889.1	锁紧螺母12 Nut	4	

液压管路 Hydraulic pipeline

FD50,60,70,80-CY1

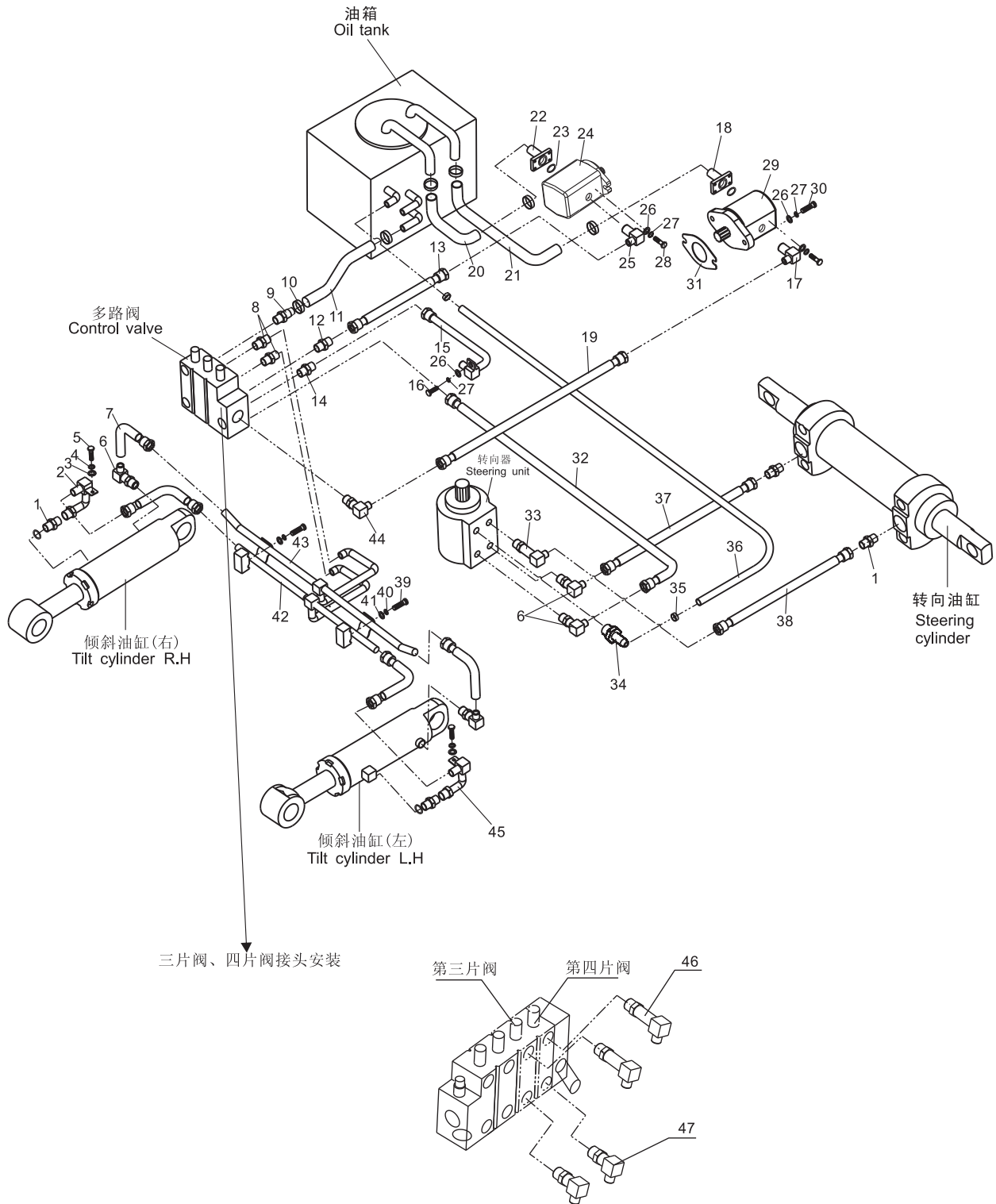

液压管路
Hydraulic pipeline

FD50,60,70,80-CY1

序号 Item	零件号 Part No	零部件名称 Description	数量 Q'ty	备注 Remark
1	GJT-51-00	直通接头 Nipple	4	
2	A50A4-00400R	接头总成(右) Nipple ass'y R.H.	1	
3	GB/T97.1	平垫6 Washer	2	
4	GB/T93	弹垫6 Washer,lock	2	
5	GB/T818	螺钉M6×16 Bolt	2	
6	GJT-55-00	直角接头 Elbow	4	
7	TGIBII-10042*G	高压胶管 10II×420 Hose H. P	4	
8	GJT-50-00	直通接头 Nipple	2	
9	GJT-48-00	回油接头 Nipple	1	
10	TK000-35051	夹箍35-51 Clip	6	
11	A50C4-00003	回油管 Hose	1	两片阀用Two-throw
-	A50C4-00004	三片阀回油管 Hose	1	三片阀用Three-throw
-	A50C4-00005	四片阀回油管 Hose	1	四片阀用Four-throw
12	GJT-49-00	直通接头 Nipple	1	
13	TGIBII-19050NL*G	高压胶管 19II×500 Hose H. P	1	
14	GJT-47-00	直通接头 Nipple	1	
15	A50A4-00300	升降缸钢管总成 Steel pipe ass'y	1	
16	GB/T5783	螺栓M10×25 Bolt	1	
17	GJT-52-00	直角接头 Elbow	1	
18	GJT-92-00	油泵进油口接头 Connector	1	
19	TGIBII-19090NL*G	高压胶管 19II×900 Hose H. P	1	标准车用
-	TGIBII-19091NL*G	高压胶管 19II×910 Hose H. P	1	欧标车用
20	A50C4-00001	前泵吸油管 Hose,suction	1	
21	A50C4-00002	后泵吸油管 Hose,suction	1	
22	GJT-58-00	油泵进油口法兰 Flange	1	
23	GB/T1235	O型密封圈36×3.5 O-ring	2	
24	A50A4-20100	前齿轮泵 Pump,front	1	

液压管路 Hydraulic pipeline

FD50,60,70,80-CY1

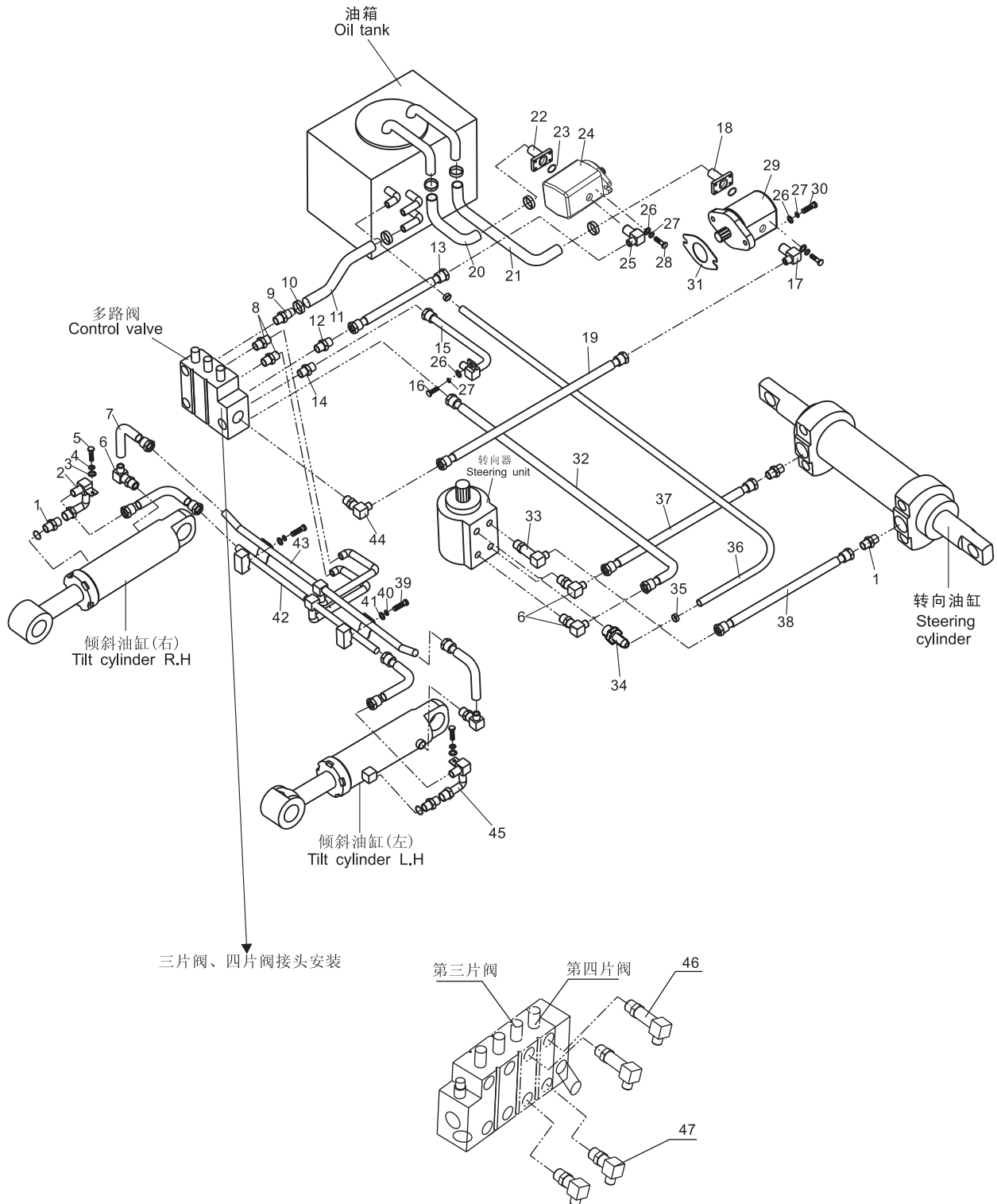

液压管路
Hydraulic pipeline

FD50,60,70,80-CY1

序号 Item	零件号 Part No	零部件名称 Description	数量 Q'ty	备注 Remark
25	GJT-43-00	出油口接头 Fuel discharge port	1	长源齿轮泵选用
-	GJT-57-00	出油口接头 Fuel discharge port	1	岛津齿轮泵选用
26	GB/T97.1	平垫10 Washer	18	
27	GB/T93	弹垫10 Washer,lock	18	
28	GB/T57830	螺栓M10×30 Bolt	16	
29	A50E4-20200	后齿轮泵 Pump,rear	1	
30	GB/T5786	螺栓M10×1.25×35 Bolt	4	
31	A50A4-00500	垫 Packing	2	
32	TGIBII-10042*G	高压胶管 10II×420 Hose H. P	1	标准车用
-	TGIBII-10047*G	高压胶管 10II×470 Hose H. P	1	欧标车用
33	GJT-54-00	直角接头 Elbow	1	
34	GJT-111-00	直通接头 Nipple	1	
35	TK000-22032	夹箍22-32 Clip	4	
36	TG000-19085	回油管 φ19×850 Hose	1	
37	TGIBI-10260*G	高压胶管 10I×2600 Hose H. P	1	
38	TGIBI-10250*G	高压胶管 10I×2500 Hose H. P	1	
39	GB/T5783	螺栓M8×25 Bolt	2	
40	GB/T93	弹垫8 Washer,lock	2	
41	GB/T97.1	平垫8 Washer	2	
42	A50A4-00100	倾斜油缸钢管总成(前) Steel pipe ass'y	1	
43	A50A4-00200	倾斜油缸钢管总成(后) Steel pipe ass'y	1	
44	GJT-57-00	直角接头 Elbow	1	
45	A50A4-00400L	接头总成(左) Nipple ass'y L.H.	1	
46	GJT-101-00	直角接头 Elbow	1	三片阀用Three-throw
-	GJT-101-00	直角接头 Elbow	2	四片阀用Four-throw
47	GJT-102-00	直角接头 Elbow	1	三片阀用Three-throw
-	GJT-102-00	直角接头 Elbow	2	四片阀用Four-throw

液压管路 Hydraulic pipeline

FD50,60,70,80-W3

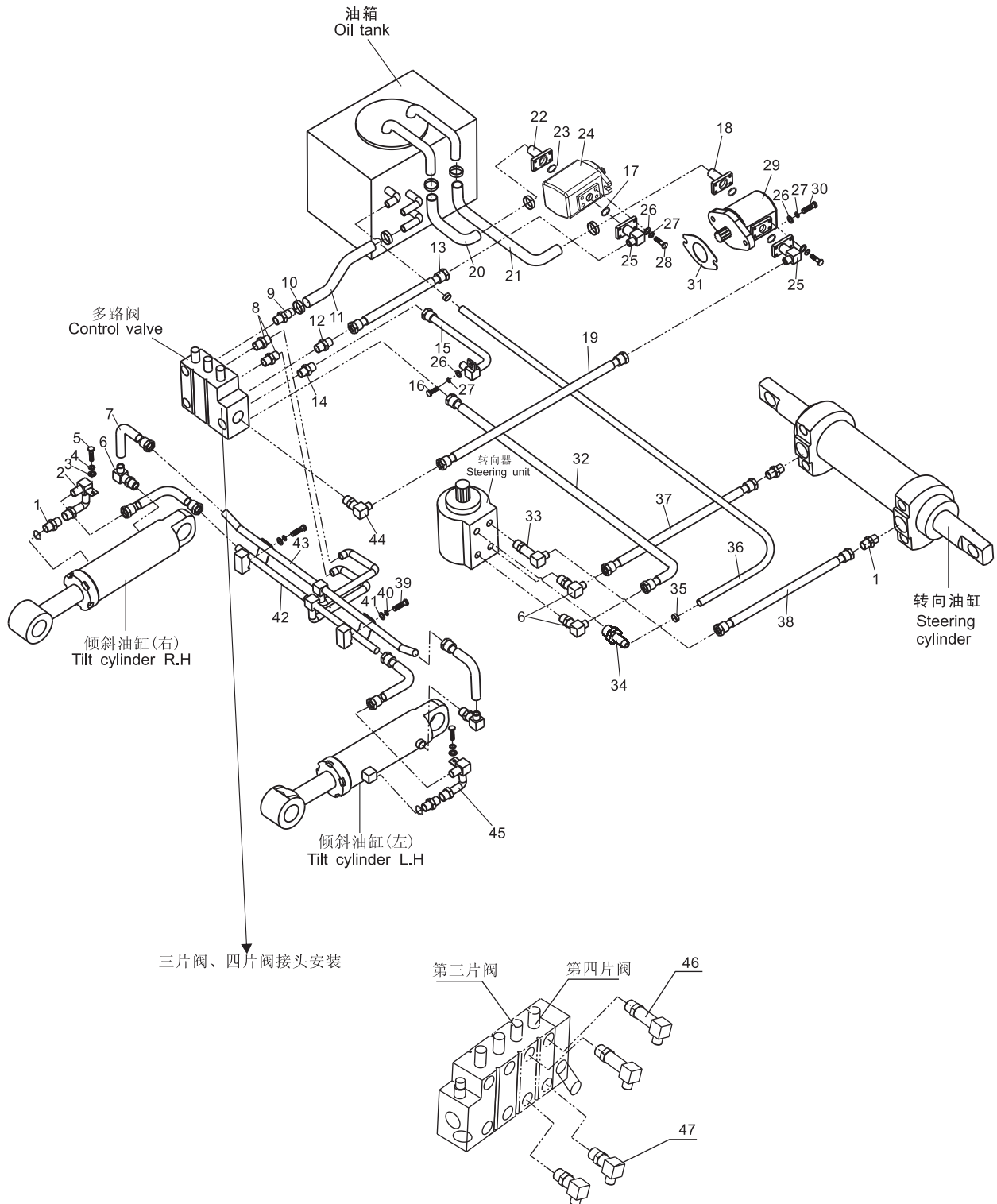

液压管路
Hydraulic pipeline

FD50,60,70,80-W3

序号 Item	零件号 Part No	零部件名称 Description	数量 Q'ty	备注 Remark
1	GJT-51-00	直通接头 Nipple	4	
2	A50A4-00400R	接头总成(右) Nipple ass'y R.H.	1	
3	GB/T97.1	平垫6 Washer	2	
4	GB/T93	弹垫6 Washer,lock	2	
5	GB/T818	螺钉M6×16 Bolt	2	
6	GJT-55-00	直角接头 Elbow	4	
7	TGIBII-10042*G	高压胶管 10II×420 Hose H. P	4	
8	GJT-50-00	直通接头 Nipple	2	
9	GJT-48-00	回油接头 Nipple	1	
10	TK000-35051	夹箍35-51 Clip	6	
11	A50C4-00003	回油管 Hose	1	两片阀用Two-throw
-	A50C4-00004	三片阀回油管 Hose	1	三片阀用Three-throw
-	A50C4-00005	四片阀回油管 Hose	1	四片阀用Four-throw
12	GJT-49-00	直通接头 Nipple	1	
13	TGIBII-19050NL*G	高压胶管 19II×500 Hose H. P	1	
14	GJT-47-00	直通接头 Nipple	1	
15	A50A4-00300	升降缸钢管总成 Steel pipe ass'y	1	
16	GB/T5783	螺栓M10×25 Bolt	1	
17	GB/T1235	O型密封圈35×3.5 O-ring	2	
18	GJT-92-00	油泵进油口接头 Connector	1	
19	TGIBII-19090NL*G	高压胶管 19II×900 Hose H. P	1	标准车用
-	TGIBII-19091NL*G	高压胶管 19II×910 Hose H. P	1	欧标车用
20	A50C4-00001	前泵吸油管 Hose,suction	1	
21	A50C4-00002	后泵吸油管 Hose,suction	1	
22	GJT-58-00	油泵进油口法兰 Flange	1	
23	GB/T1235	O型密封圈36×3.5 O-ring	2	
24	A50B4-20100	前齿轮泵 Pump,front	1	

液压管路 Hydraulic pipeline

FD50,60,70,80-W3

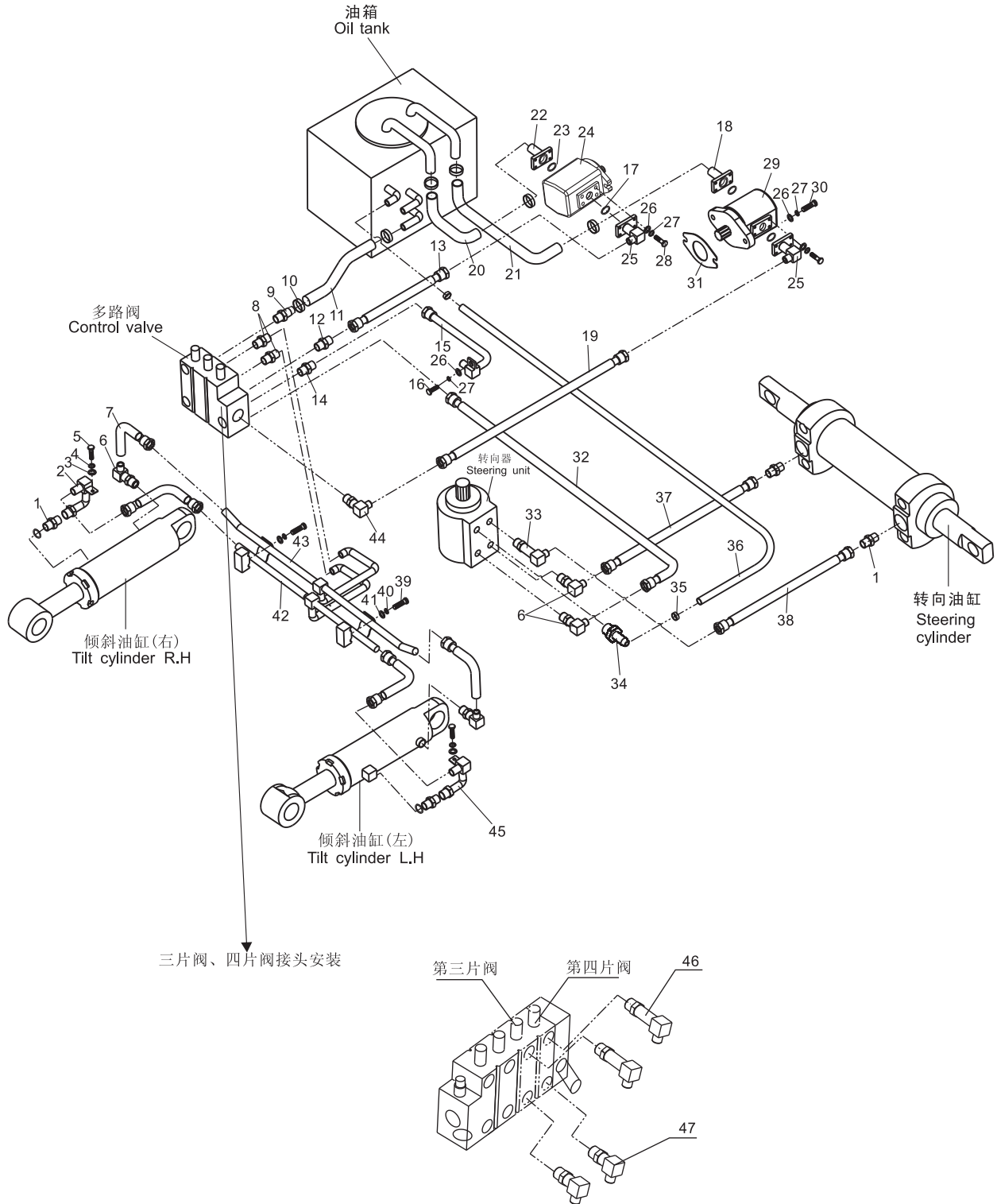

液压管路
Hydraulic pipeline

FD50,60,70,80-W3

序号 Item	零件号 Part No	零部件名称 Description	数量 Q'ty	备注 Remark
25	GJT-43-00	出油口接头 Fuel discharge port	2	长源齿轮泵选用
-	GJT-57-00	出油口接头 Fuel discharge port	2	岛津齿轮泵选用
26	GB/T97.1	平垫10 Washer	18	
27	GB/T93	弹垫10 Washer,lock	18	
28	GB/T57830	螺栓M10×30 Bolt	16	
29	A50B4-20200	后齿轮泵 Pump,rear	1	
30	GB/T5786	螺栓M10×1.25×35 Bolt	4	
31	A50A4-00500	垫 Packing	2	
32	TGIBII-10042*G	高压胶管 10II×420 Hose H. P	1	标准车用
-	TGIBII-10047*G	高压胶管 10II×470 Hose H. P	1	欧标车用
33	GJT-54-00	直角接头 Elbow	1	
34	GJT-111-00	直通接头 Nipple	1	
35	TK000-22032	夹箍22-32 Clip	4	
36	TG000-19085	回油管 φ19×850 Hose	1	
37	TGIBI-10260*G	高压胶管 10I×2600 Hose H. P	1	
38	TGIBI-10250*G	高压胶管 10I×2500 Hose H. P	1	
39	GB/T5783	螺栓M8×25 Bolt	2	
40	GB/T93	弹垫8 Washer,lock	2	
41	GB/T97.1	平垫8 Washer	2	
42	A50A4-00100	倾斜油缸钢管总成(前) Steel pipe ass'y	1	
43	A50A4-00200	倾斜油缸钢管总成(后) Steel pipe ass'y	1	
44	GJT-57-00	直角接头 Elbow	1	
45	A50A4-00400L	接头总成(左) Nipple ass'y L.H.	1	
46	GJT-101-00	直角接头 Elbow	1	三片阀用Three-throw
-	GJT-101-00	直角接头 Elbow	2	四片阀用Four-throw
47	GJT-102-00	直角接头 Elbow	1	三片阀用Three-throw
-	GJT-102-00	直角接头 Elbow	2	四片阀用Four-throw

液压管路 Hydraulic pipeline

FD50,60,70,80-S3

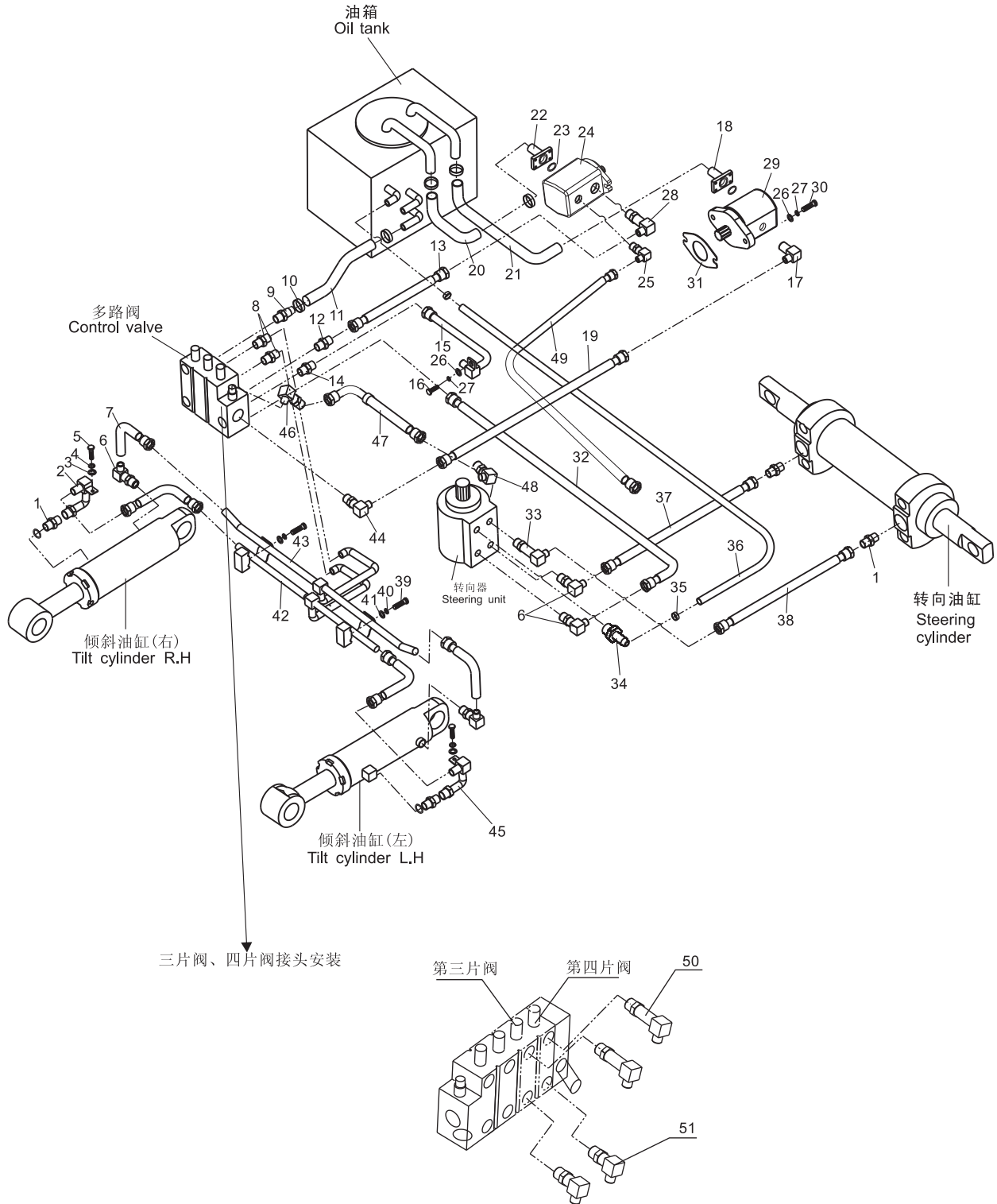

液压管路
Hydraulic pipeline

FD50,60,70,80-S3

序号 Item	零件号 Part No	零部件名称 Description	数量 Q'ty	备注 Remark
1	GJT-51-00	直通接头 Nipple	4	
2	A50A4-00400R	接头总成(右) Nipple ass'y R.H.	1	
3	GB/T97.1	平垫6 Washer	2	
4	GB/T93	弹垫6 Washer,lock	2	
5	GB/T818	螺钉M6×16 Bolt	2	
6	GJT-55-00	直角接头 Elbow	4	
7	TGIBII-10042*G	高压胶管 10II×420 Hose H. P	4	
8	GJT-50-00	直通接头 Nipple	2	
9	GJT-48-00	回油接头 Nipple	1	
10	TK000-35051	夹箍35-51 Clip	6	
11	A50C4-00003	回油管 Hose	1	两片阀用Two-throw
-	A50C4-00004	三片阀回油管 Hose	1	三片阀用Three-throw
-	A50C4-00005	四片阀回油管 Hose	1	四片阀用Four-throw
12	GJT-49-00	直通接头 Nipple	1	
13	TGIBII-19050NL*G	高压胶管 19II×500 Hose H. P	1	
14	GJT-47-00	直通接头 Nipple	1	
15	A50A4-00300	升降缸钢管总成 Steel pipe ass'y	1	
16	GB/T5783	螺栓M10×25 Bolt	1	
17	GJT-52-00	直角接头 Elbow	1	
18	GJT-92-00	油泵进油口接头 Connector	1	
19	TGIBII-19090NL*G	高压胶管 19II×900 Hose H. P	1	标准车用
-	TGIBII-19091NL*G	高压胶管 19II×910 Hose H. P	1	欧标车用
20	A50C4-00001	前泵吸油管 Hose,suction	1	
21	A50C4-00002	后泵吸油管 Hose,suction	1	
22	GJT-58-00	油泵进油口法兰 Flange	1	
23	GB/T1235	O型密封圈36×3.5 O-ring	2	
24	A50E4-20100	前齿轮泵 Pump,front	1	

液压管路 Hydraulic pipeline

FD/Y50,60,70,80-S3/G3/G4

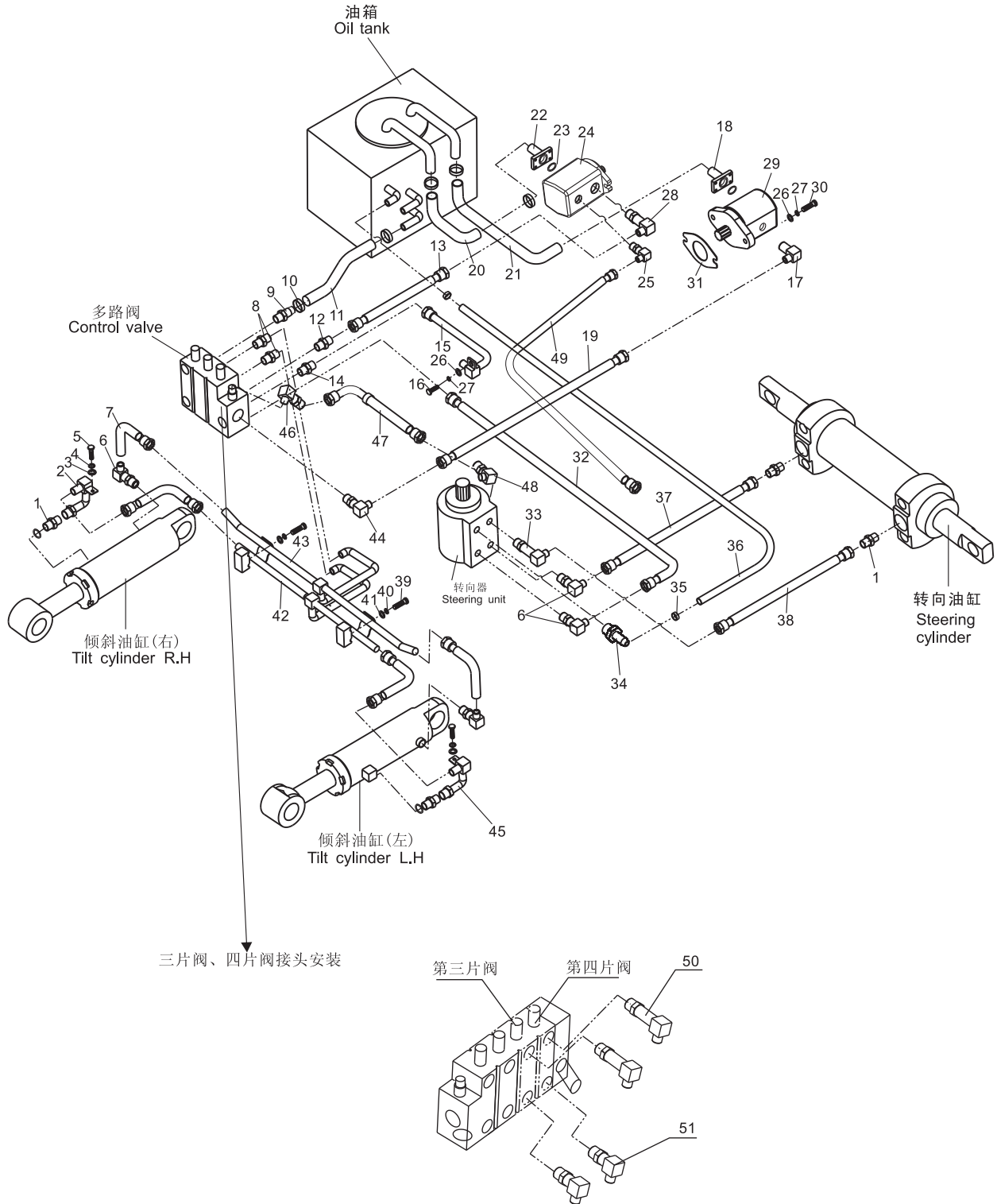

液压管路
Hydraulic pipeline

FD/Y50,60,70,80-S3/G3/G4

序号 Item	零件号 Part No	零部件名称 Description	数量 Q'ty	备注 Remark
25	GJT-52-00	出油口接头 Fuel discharge port	1	
26	GB/T97.1	平垫10 Washer	18	
27	GB/T93	弹垫10 Washer,lock	18	
28	GJT-144-00	直角接头 Elbow	1	
29	A50E4-20200	后齿轮泵 Pump,rear	1	
30	GB/T5786	螺栓M10×1.25×35 Bolt	4	
31	A50A4-00500	垫 Packing	2	
32	TGIBII-10042*G	高压胶管 10II×420 Hose H. P	1	标准车用
-	TGIBII-10047*G	高压胶管 10II×470 Hose H. P	1	欧标车用
33	GJT-54-00	直角接头 Elbow	1	
34	GJT-111-00	直通接头 Nipple	1	
35	TK000-22032	夹箍22-32 Clip	4	
36	TG000-19120	回油管 φ 19×1200 Hose	1	
37	TGIBI-10260*G	高压胶管 10I×2600 Hose H. P	1	
38	TGIBI-10250*G	高压胶管 10I×2500 Hose H. P	1	
39	GB/T5783	螺栓M8×25 Bolt	2	
40	GB/T93	弹垫8 Washer,lock	2	
41	GB/T97.1	平垫8 Washer	2	
42	A50A4-00100	倾斜油缸钢管总成(前) Steel pipe ass'y	1	
43	A50A4-00200	倾斜油缸钢管总成(后) Steel pipe ass'y	1	
44	GJT-57-00	直角接头 Elbow	1	
45	A50A4-00400L	接头总成(左) Nipple ass'y L.H.	1	
46	GJT-174-00	直角接头 Elbow	1	
47	TGLBI-06032-H30*G	高压胶管 6I×320 Hose H. P	1	
48	GJT-344-00	135° 接头 Connector	1	
49	TGIBI-10070*G	高压胶管 10I×700 Hose H. P	1	

液压管路 Hydraulic pipeline

FD/Y50,60,70,80-S3/G3/G4

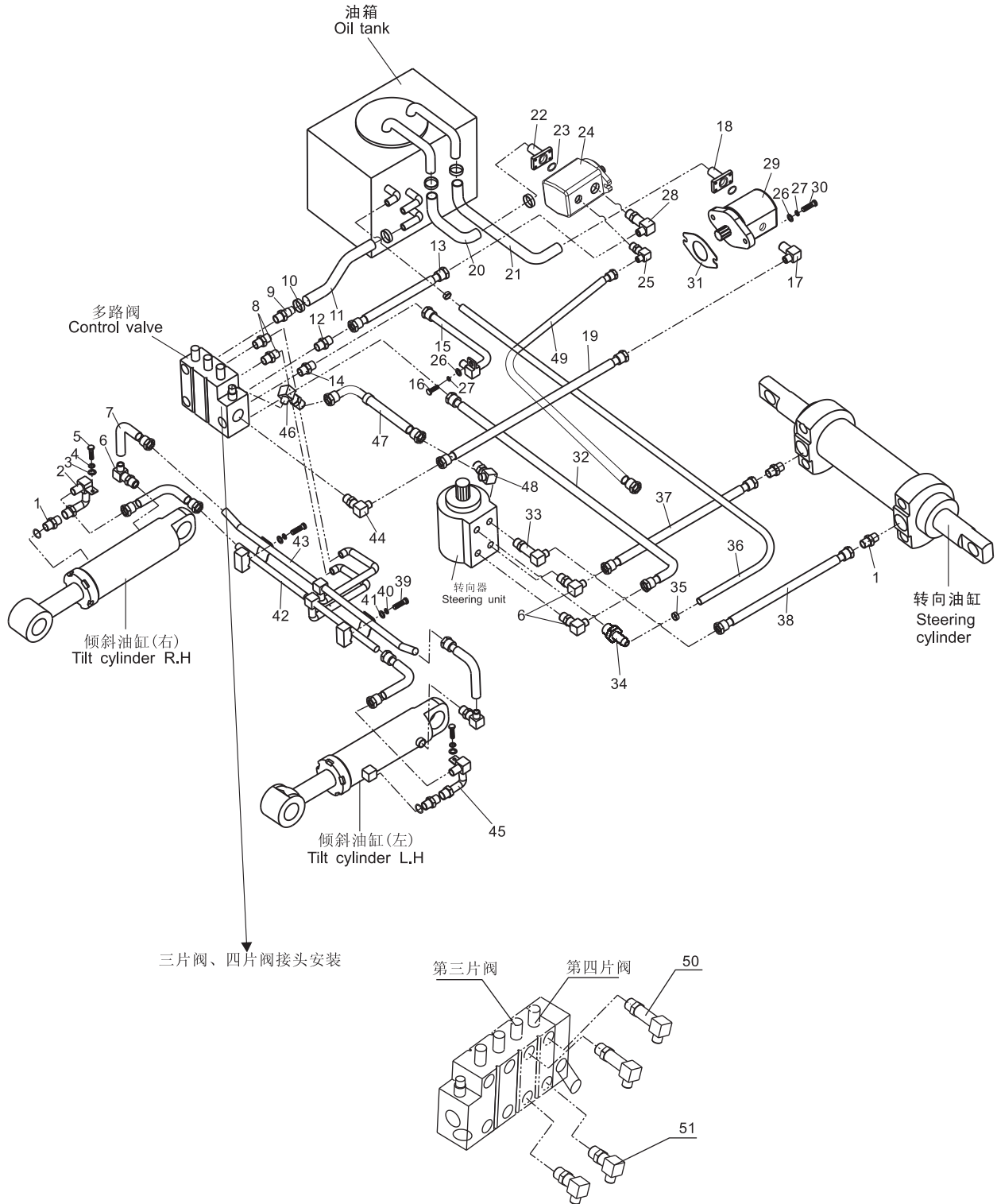

液压管路
Hydraulic pipeline

FD/Y50,60,70,80-S3/G3/G4

序号 Item	零件号 Part No	零部件名称 Description	数量 Q'ty	备注 Remark
46	GJT-101-00	直角接头 Elbow	1	三片阀用Three-throw
-	GJT-101-00	直角接头 Elbow	2	四片阀用Four-throw
47	GJT-102-00	直角接头 Elbow	1	三片阀用Three-throw
-	GJT-102-00	直角接头 Elbow	2	四片阀用Four-throw

液压管路 Hydraulic pipeline

FD50,60,70,80-YC2

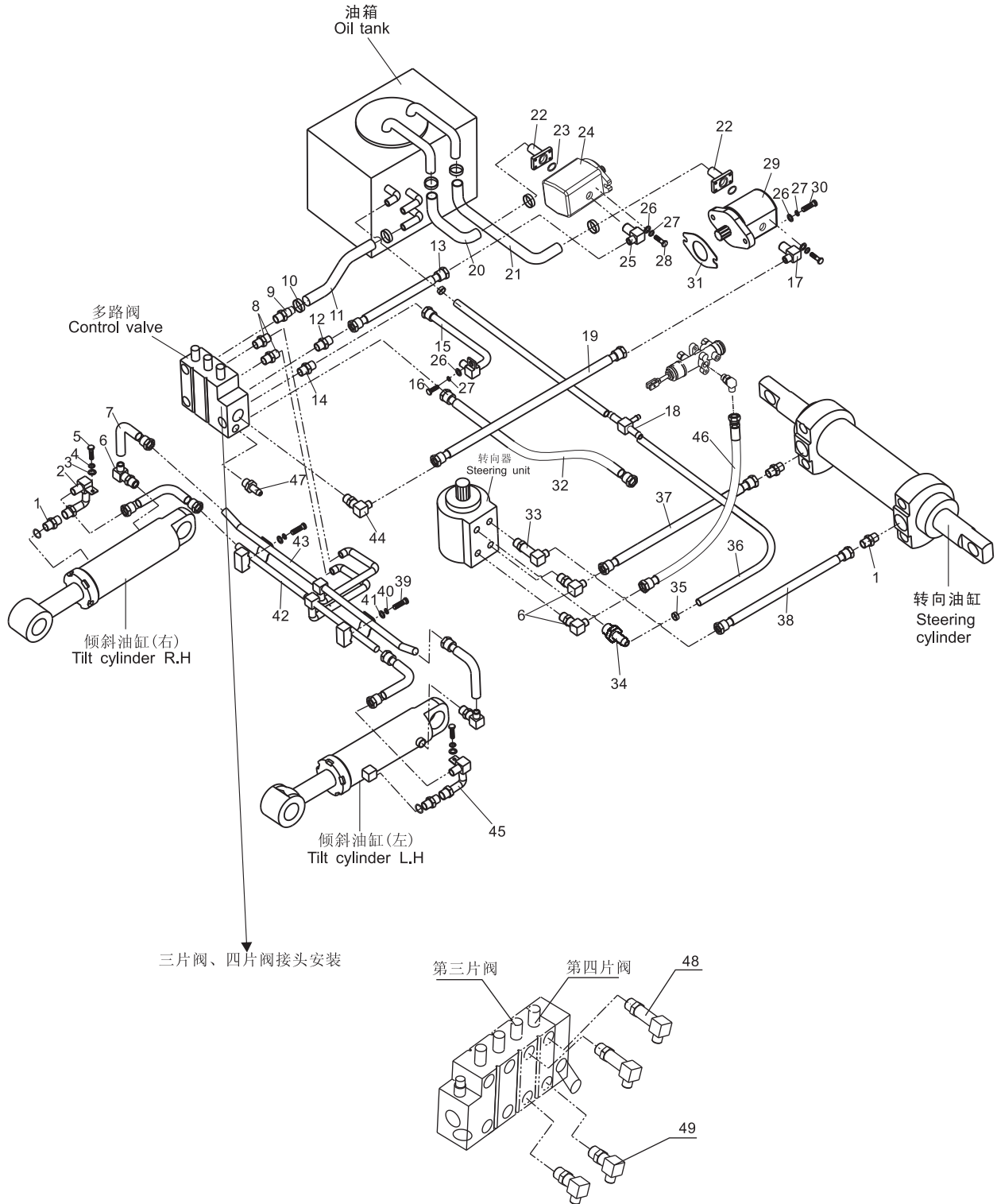

液压管路
Hydraulic pipeline

FD50,60,70,80-YC2

序号 Item	零件号 Part No	零部件名称 Description	数量 Q'ty	备注 Remark
1	GJT-51-00	直通接头 Nipple	4	
2	A50A4-00400R	接头总成(右) Nipple ass'y R.H.	1	
3	GB/T97.1	平垫6 Washer	2	
4	GB/T93	弹垫6 Washer,lock	2	
5	GB/T818	螺钉M6×16 Bolt	2	
6	GJT-55-00	直角接头 Elbow	4	
7	TGIBII-10042*G	高压胶管 10II×420 Hose H. P	4	
8	GJT-50-00	直通接头 Nipple	2	
9	GJT-48-00	回油接头 Nipple	1	
10	TK000-35051	夹箍35-51 Clip	6	
11	A50C4-00003	回油管 Hose	1	两片阀用Two-throw
-	A50C4-00004	三片阀回油管 Hose	1	三片阀用Three-throw
-	A50C4-00005	四片阀回油管 Hose	1	四片阀用Four-throw
12	GJT-49-00	直通接头 Nipple	1	
13	TGIBII-19050NL*G	高压胶管 19II×500 Hose H. P	1	
14	GJT-47-00	直通接头 Nipple	1	
15	A50A4-00300	升降缸钢管总成 Steel pipe ass'y	1	
16	GB/T5783	螺栓M10×25 Bolt	1	
17	GJT-52-00	直角接头 Elbow	1	
18	GJT-204-00	三通接头 Connector	1	
19	TGIBII-19090NL*G	高压胶管 19II×900 Hose H. P	1	标准车用
-	TGIBII-19091NL*G	高压胶管 19II×910 Hose H. P	1	欧标车用
20	A50C4-00001	前泵吸油管 Hose,suction	1	
21	A50C4-00002	后泵吸油管 Hose,suction	1	
22	GJT-58-00	油泵进油口法兰 Flange	2	
23	GB/T1235	O型密封圈36×3.5 O-ring	2	
24	A50A4-20100	前齿轮泵 Pump,front	1	

液压管路 Hydraulic pipeline

FD50,60,70,80-YC2

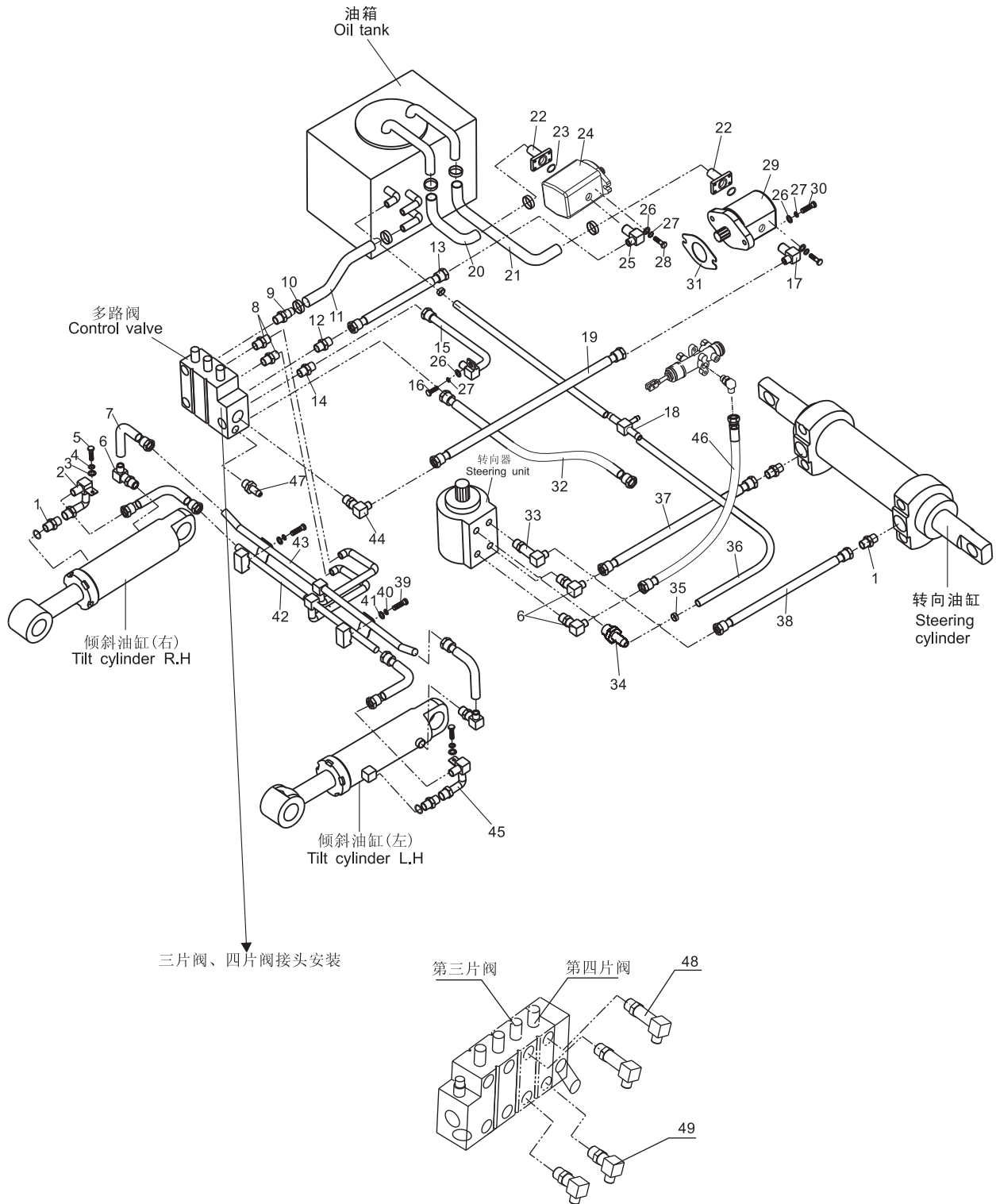

液压管路
Hydraulic pipeline

FD50,60,70,80-YC2

序号 Item	零件号 Part No	零部件名称 Description	数量 Q'ty	备注 Remark
25	GJT-43-00	出油口接头 Fuel discharge port	1	长源齿轮泵选用
-	GJT-57-00	出油口接头 Fuel discharge port	1	岛津齿轮泵选用
26	GB/T97.1	平垫10 Washer	18	
27	GB/T93	弹垫10 Washer,lock	18	
28	GB/T57830	螺栓M10×30 Bolt	16	
29	A50A4-20200	后齿轮泵 Pump,rear	1	
30	GB/T5786	螺栓M10×1.25×35 Bolt	4	
31	A50A4-00500	垫 Packing	2	
32	TGIBII-10052*G	高压胶管 10II×520 Hose H. P	1	标准车用
-	TGIBII-10057*G	高压胶管 10II×570 Hose H. P	1	欧标车用
33	GJT-54-00	直角接头 Elbow	1	
34	GJT-111-00	直通接头 Nipple	1	
35	TK000-22032	夹箍22-32 Clip	4	
36	TG000-19085	回油管 φ 19×850 Hose	1	
37	TGIBI-10260*G	高压胶管 10I×2600 Hose H. P	1	
38	TGIBI-10250*G	高压胶管 10I×2500 Hose H. P	1	
39	GB/T5783	螺栓M8×25 Bolt	2	
40	GB/T93	弹垫8 Washer,lock	2	
41	GB/T97.1	平垫8 Washer	2	
42	A50A4-00100	倾斜油缸钢管总成(前) Steel pipe ass'y	1	
43	A50A4-00200	倾斜油缸钢管总成(后) Steel pipe ass'y	1	
44	GJT-57-00	直角接头 Elbow	1	
45	A50A4-00400L	接头总成(左) Nipple ass'y L.H.	1	
46	TGIBI-10088*G	高压胶管 10I×880 Hose H. P	1	
47	GJT-90-00	直通接头 Nipple	1	

液压管路 Hydraulic pipeline

FD50,60,70,80-YC2

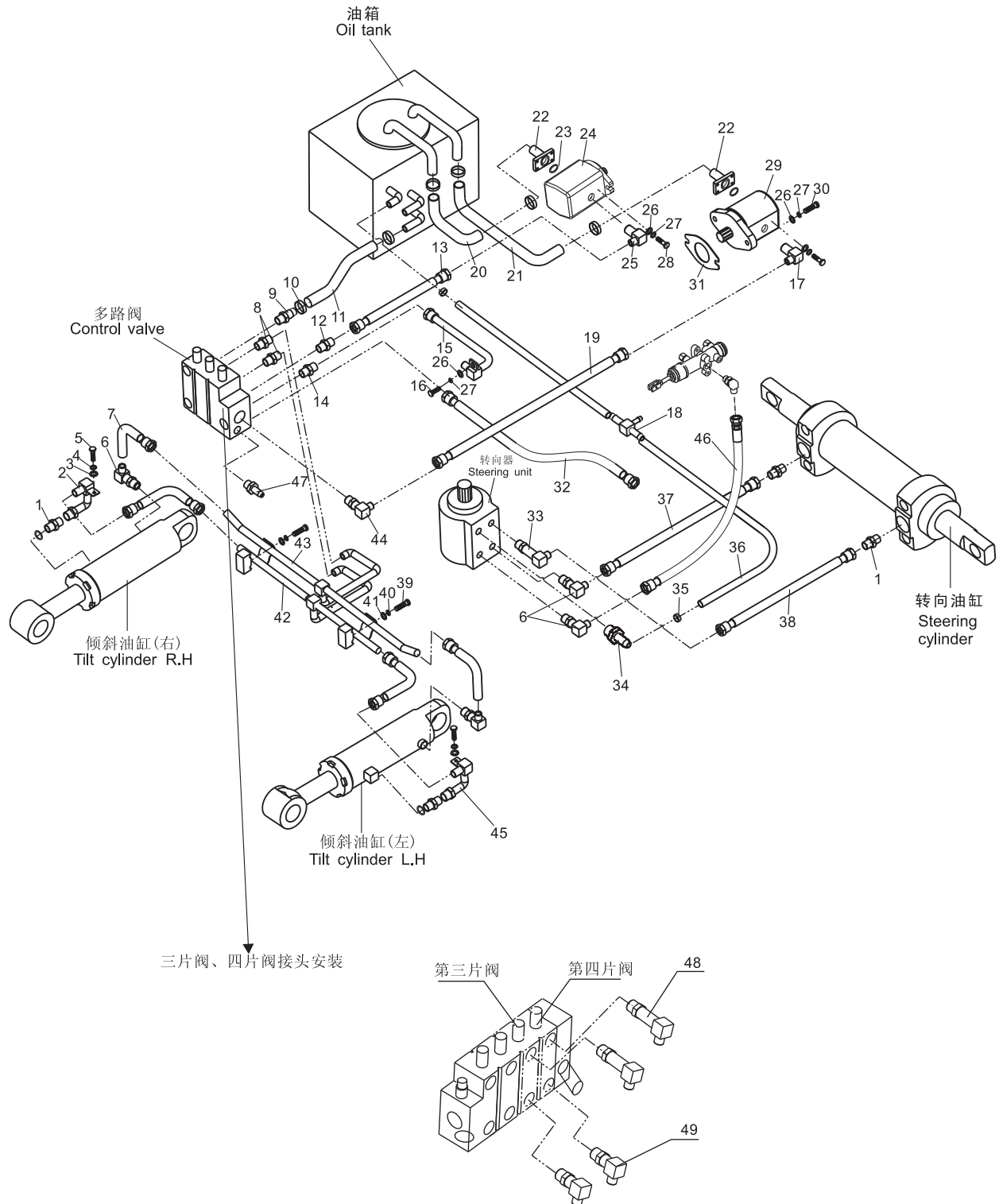

液压管路
Hydraulic pipeline

FD50,60,70,80-YC2

序号 Item	零件号 Part No	零部件名称 Description	数量 Q'ty	备注 Remark
48	GJT-101-00	直角接头 Elbow	1	三片阀用Three-throw
-	GJT-101-00	直角接头 Elbow	2	四片阀用Four-throw
49	GJT-102-00	直角接头 Elbow	1	三片阀用Three-throw
-	GJT-102-00	直角接头 Elbow	2	四片阀用Four-throw

液压管路 Hydraulic pipeline

FD50,60,70,80-KMS2

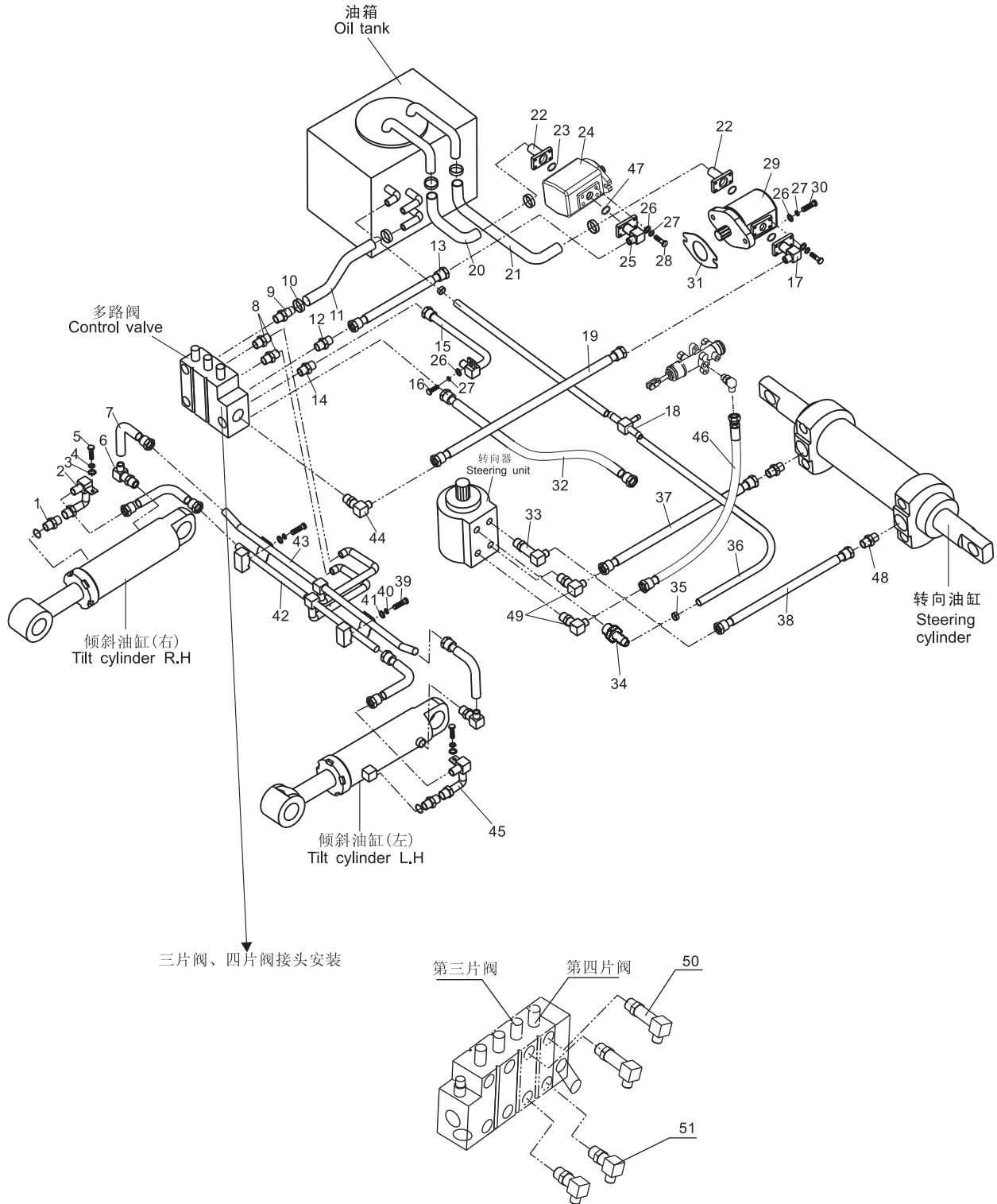

液压管路
Hydraulic pipeline

FD50,60,70,80-KMS2

序号 Item	零件号 Part No	零部件名称 Description	数量 Q'ty	备注 Remark
1	GJT-51-00	直通接头 Nipple	42	
2	A50A4-00400R	接头总成(右) Nipple ass'y R.H.	1	
3	GB/T97.1	平垫6 Washer	2	
4	GB/T93	弹垫6 Washer,lock	2	
5	GB/T818	螺钉M6×16 Bolt	2	
6	GJT-55-00	直角接头 Elbow	2	
7	TGIBII-10042*G	高压胶管 10II×420 Hose H. P	4	
8	GJT-50-00	直通接头 Nipple	2	
9	GJT-48-00	回油接头 Nipple	1	
10	TK000-35051	夹箍35-51 Clip	6	
11	A50C4-00003	回油管 Hose	1	两片阀用Two-throw
-	A50C4-00004	三片阀回油管 Hose	1	三片阀用Three-throw
-	A50C4-00005	四片阀回油管 Hose	1	四片阀用Four-throw
12	GJT-49-00	直通接头 Nipple	1	
13	TGIBII-19050NL*G	高压胶管 19II×500 Hose H. P	1	
14	GJT-382-00	直通接头 Nipple	1	
15	A90F4-00100	钢管总成 Steel pipe ass'y	1	
16	GB/T5783	螺栓M10×25 Bolt	1	
17	GJT-52-00	直角接头 Elbow	1	
18	GJT-204-00	三通接头 Connector	1	
19	TGIBII-19090NL*G	高压胶管 19II×900 Hose H. P	1	标准车用
-	TGIBII-19091NL*G	高压胶管 19II×910 Hose H. P	1	欧标车用
20	A50C4-00001	前泵吸油管 Hose,suction	1	
21	A50C4-00002	后泵吸油管 Hose,suction	1	
22	GJT-58-00	油泵进油口法兰 Flange	2	
23	GB/T1235	O型密封圈36×3.5 O-ring	2	
24	A50B4-20100	前齿轮泵 Pump,front	1	

液压管路 Hydraulic pipeline

FD50,60,70,80-KMS2

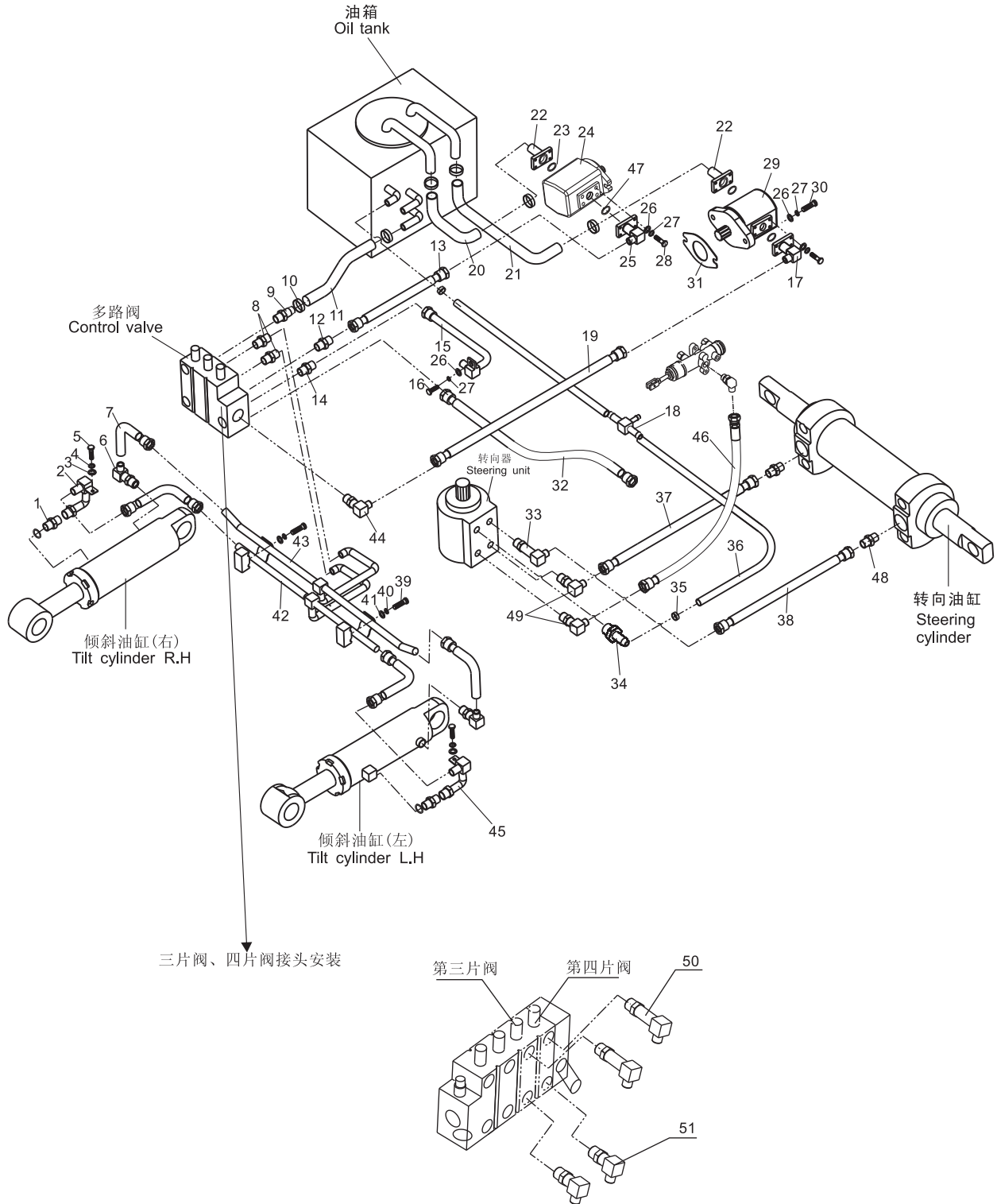

液压管路
Hydraulic pipeline

FD50,60,70,80-KMS2

序号 Item	零件号 Part No	零部件名称 Description	数量 Q'ty	备注 Remark
25	GJT-43-00	出油口接头 Fuel discharge port	1	长源齿轮泵选用
-	GJT-57-00	出油口接头 Fuel discharge port	1	岛津齿轮泵选用
26	GB/T97.1	平垫10 Washer	18	
27	GB/T93	弹垫10 Washer,lock	18	
28	GB/T57830	螺栓M10×30 Bolt	16	
29	A50B4-20200	后齿轮泵 Pump,rear	1	
30	GB/T5786	螺栓M10×1.25×35 Bolt	4	
31	A50A4-00500	垫 Packing	2	
32	TGIBII-10052*G	高压胶管 10II×520 Hose H. P	1	标准车用
-	TGIBII-10057*G	高压胶管 10II×570 Hose H. P	1	欧标车用
33	GJT-383-00	直角接头 Elbow	1	
34	GJT-111-00	直通接头 Nipple	1	
35	TK000-22032	夹箍22-32 Clip	4	
36	TG000-19110	回油管 φ19×1100 Hose	1	
37	TGIBI-10260*G	高压胶管 10I×2600 Hose H. P	1	
38	TGIBI-10250*G	高压胶管 10I×2500 Hose H. P	1	
39	GB/T5783	螺栓M8×25 Bolt	2	
40	GB/T93	弹垫8 Washer,lock	2	
41	GB/T97.1	平垫8 Washer	2	
42	A50A4-00100	倾斜油缸钢管总成(前) Steel pipe ass'y	1	
43	A50A4-00200	倾斜油缸钢管总成(后) Steel pipe ass'y	1	
44	GJT-57-00	直角接头 Elbow	1	
45	A50A4-00400L	接头总成(左) Nipple ass'y L.H.	1	
46	TGICI-10088*G	高压胶管 10I×880 Hose H. P	1	
47	GB/T1235	O型密封圈35×3.5 O-ring	2	
48	GJT-51-00	直角接头 Elbow	2	
49	GJT-55-00	直角接头 Elbow	2	

液压管路 Hydraulic pipeline

FD50,60,70,80-KMS2

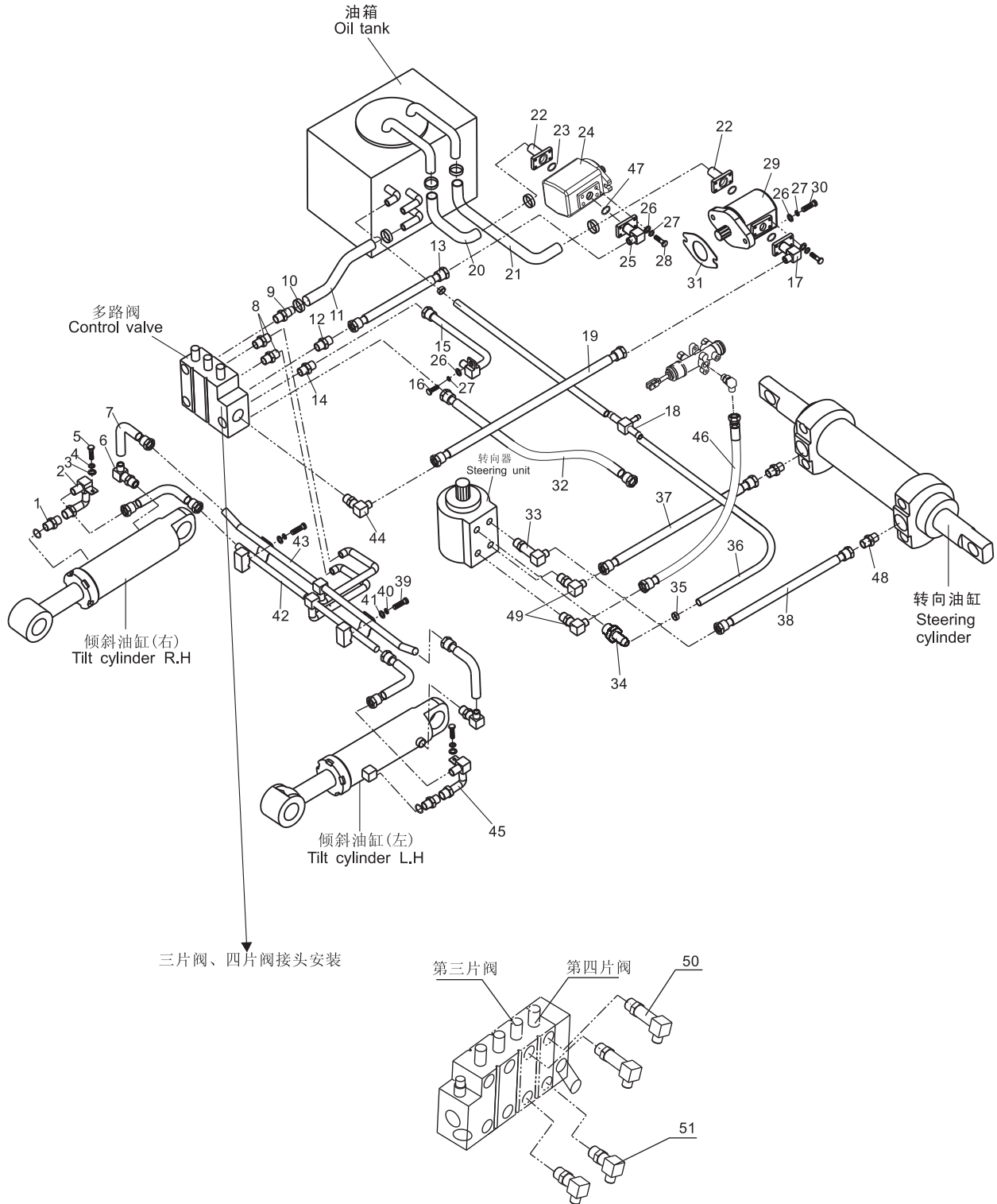

液压管路
Hydraulic pipeline

FD50,60,70,80-KMS2

序号 Item	零件号 Part No	零部件名称 Description	数量 Q'ty	备注 Remark
50	GJT-101-00	直角接头 Elbow	1	三片阀用Three-throw
-	GJT-101-00	直角接头 Elbow	2	四片阀用Four-throw
51	GJT-102-00	直角接头 Elbow	1	三片阀用Three-throw
-	GJT-102-00	直角接头 Elbow	2	四片阀用Four-throw

八、起重系统

LIFTING SYSTEM

门架管路系统（基本型）
Hydraulic system mast(Normal mast KM)

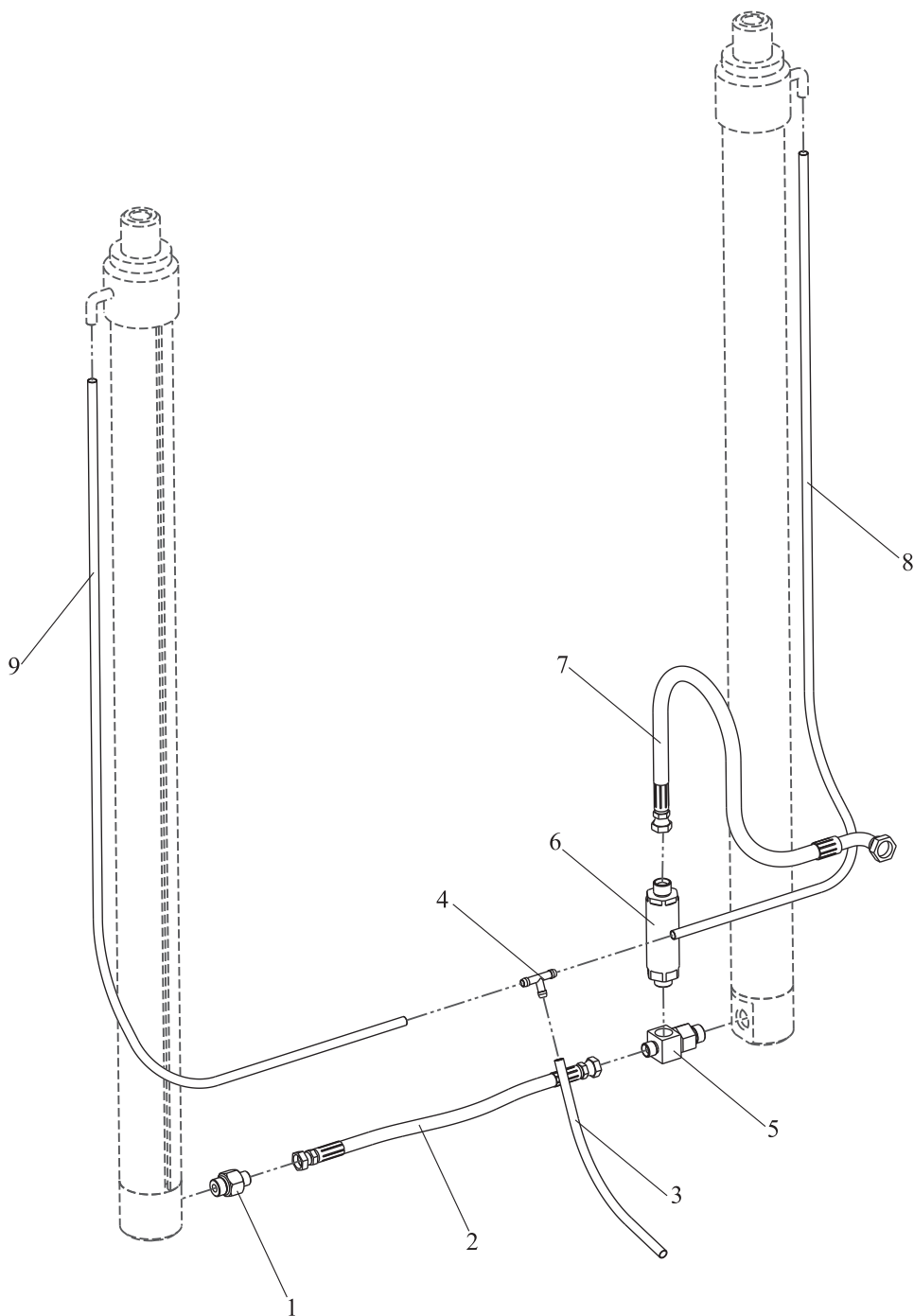

门架管路系统（基本型）
Hydraulic system mast(Normal mast KM)

序号 Item	零件号 Part No	零部件名称 Description	数量 Q'ty	备注 Remark
1	GJT-42-00	直通接头 Nipple	1	EX-B
-	GJT-404-00	直通接头 Nipple	1	EX-A
2	TGIBII-13056*J	高压胶管13II×560 Hose H.P.	1	EX-B
-	TGICII-13058*J	高压胶管13II×580 Hose H.P.	1	EX-A
3	TG000-120XX	塑料管d12×L3 Tube vinyl	1	
4	GJT-01-00	回油接头 Joint	1	
5	GJT-41-00	三通接头 Three way connector	1	EX-B
-	GJT-422-00	三通接头 Three way connector	1	EX-A
6	GJT-40-00	限速阀 Flow regulator	1	EX-B
-	GJT-402-00	限速阀 Flow regulator	1	EX-A
7	TGLBII-19084-H55GS*J	高压胶管19II×840 Hose H.P.	1	EX-B
-	TGLCII-19084-H55GS*J	高压胶管19II×840 Hose H.P.	1	EX-A
8	TG000-120XX	塑料管d12×L1 Tube vinyl	1	
9	TG000-120XX	塑料管d12×L2 Tube vinyl	1	

门架管路系统（两节全自由） Hydraulic system mast(Full Free 2-Stage Mast KZM)

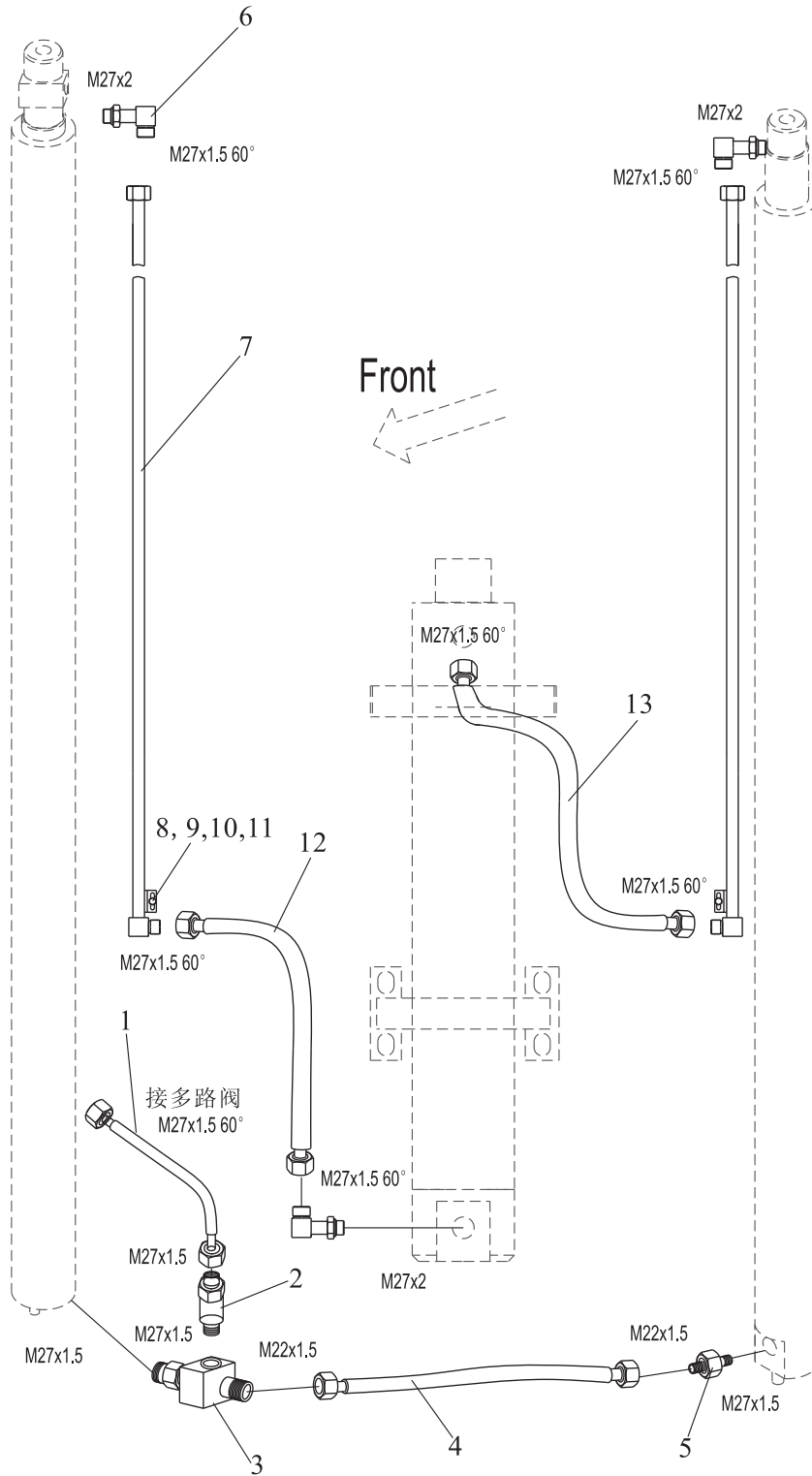

门架管路系统（两节全自由）
Hydraulic system mast(Full Free 2-Stage Mast KZM)

序号 Item	零件号 Part No	零部件名称 Description	数量 Q'ty	备注 Remark
1	TGLBII-190100-H55GS*J	高压胶管19II×1000 Hose H.P.	1	EX-B
-	TGLCII-190100-H55GS*J	高压胶管19II×1000 Hose H.P.	1	EX-A
2	GJT-40-00	限速阀 Flow regulator	1	EX-B
-	GJT-402-00	限速阀 Flow regulator	1	EX-A
3	GJT-446-00	三通接头 Three way connector	1	EX-B
-	GJT-447-00	三通接头 Three way connector	1	EX-A
4	TGIBII-13058*J	高压胶管13II×580 Hose H.P.	1	EX-B
-	TGICII-13058*J	高压胶管13II×580 Hose H.P.	1	EX-A
5	GJT-42-00	直通接头 Nipple	1	EX-B
-	GJT-404-00	直通接头 Nipple	1	EX-A
6	GJT-160-00	直角接头 Nipple	3	
7	Z70B3-70100-XXXX	钢管总成 Steel tube ass'y	2	
8	GB/T5783	螺栓M8×25 Bolt	2	
9	GB/T93	弹垫 8 Washer,lock	2	
10	GB/T97.1	平垫 8 Washer	2	
11	GB/T6170	螺母M8 Nut	2	
12	TGIBII-16080*J	高压胶管16II×800 Hose H.P.	1	
13	TGIBII-16XXX*G	高压胶管16II×XXX Hose H.P.	1	

门架管路系统（两节全自由）
Hydraulic system mast(Full Free 2-Stage Mast KZM)

管路系统选用件（Mast Piping Optional Parts）				
起升高度 Lifting Height	件7代号 Part No	件7长度 Hose(mm)	件13代号 Part No	件13长度 Hose(mm)
2300	Z70B3-70100-Z230	870	TGIBI-16045*G	450
2500	Z70B3-70100-Z250	970	TGIBI-16043*G	430
3000	Z70B3-70100-Z300	1220	TGIBI-16045*G	450
3300	Z70B3-70100-Z330	1370	TGIBI-16050*G	500
3500	Z70B3-70100-Z350	1470	TGIBI-16054*G	540
3700	Z70B3-70100-Z370	1570	TGIBI-16057*G	570
4000	Z70B3-70100-Z400	1770	TGIBI-16065*G	650
4500	Z70B3-70100-Z450	2020	TGIBI-16075*G	750
5000	Z70B3-70100-Z500	2270	TGIBI-16085*G	850
5500	Z70B3-70100-Z550	2570	TGIBI-16105*G	1050
6000	Z70B3-70100-Z600	2820	TGIBI-16115*G	1150

门架管路系统（三节全自由） Hydraulic system mast(Full Free 3-Stage Mast KZM)

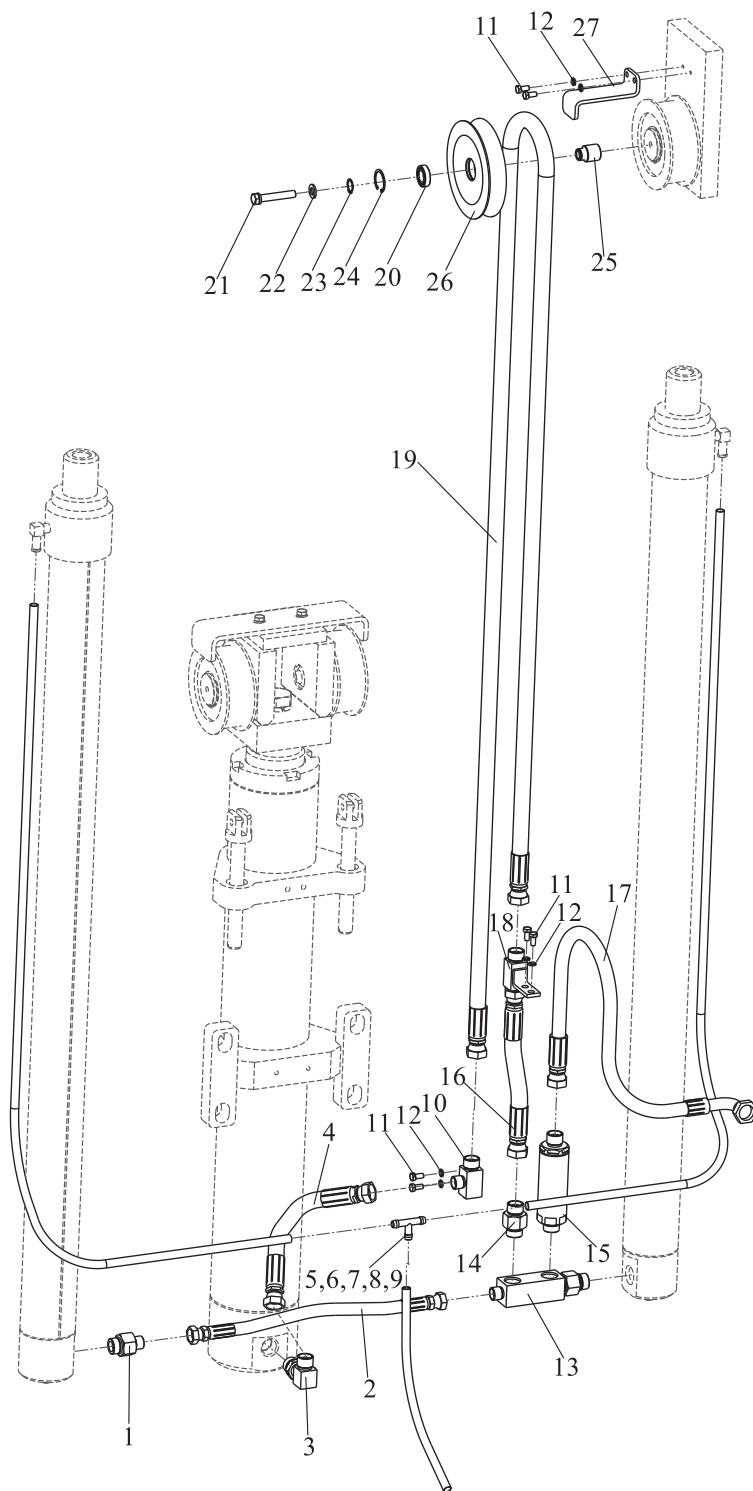

门架管路系统（三节全自由）

Hydraulic system mast(Full Free 3-Stage Mast KZM)

序号 Item	零件号 Part No	零部件名称 Description	数量 Q'ty	备注 Remark
1	GJT-42-00	直通接头 Nipple	1	EX-B
-	GJT-404-00	直通接头 Nipple	1	EX-A
2	TGIBII-13048*J	高压胶管13II×480 Hose H.P.	1	EX-B
-	TGICII-13048*J	高压胶管13II×480 Hose H.P.	1	EX-A
3	GJT-160-00	直角接头 Nipple	1	
4	TGIBII-16047*J	高压胶管16II×470 Hose H.P.	1	EX-B
-	TGICII-16047*J	高压胶管16II×470 Hose H.P.	1	EX-A
5	GJT-01-00	回油接头 Joint	1	
6	TG000-12XX	塑料管d12 Tube vinyl	1	
7	TG000-12120	塑料管d12×1200 Tube vinyl	1	
8	TQ000-08040	扎带 Binding	4	
9	TG000-12XX	塑料管d12 Tube vinyl	1	
10	GJT-307-00	直角接头 Nipple	1	EX-B
-	GJT-440-00	二通接头 Two-way coupling	1	EX-A
11	GB/T5783	螺栓M8×16 Bolt	6	
12	GB/T93	弹垫 8 Washer,lock	6	
13	GJT-318-00	四通接头总成 Four way connector	1	EX-B
-	GJT-443-00	四通接头总成 Four way connector	1	EX-A
14	GJT-172-00	直通接头 Nipple	1	EX-B
-	GJT-380-00	直通接头 Nipple	1	EX-A
15	GJT-40-00	限速阀 Flow regulator	1	
16	TGIBII-16035*J	高压胶管16II×350 Hose H.P.	1	
17	TGLBII-19084-H55GS*J	高压胶管19II×840 Hose H.P.	1	
18	GJT-319-00	直通接头 Nipple	1	EX-B
-	GJT-441-00	直通接头 Nipple	1	EX-A
19	TGIBII-16XXX*J	高压胶管16II×XXX Hose H.P.	1	

门架管路系统（三节全自由） Hydraulic system mast(Full Free 3-Stage Mast KZM)

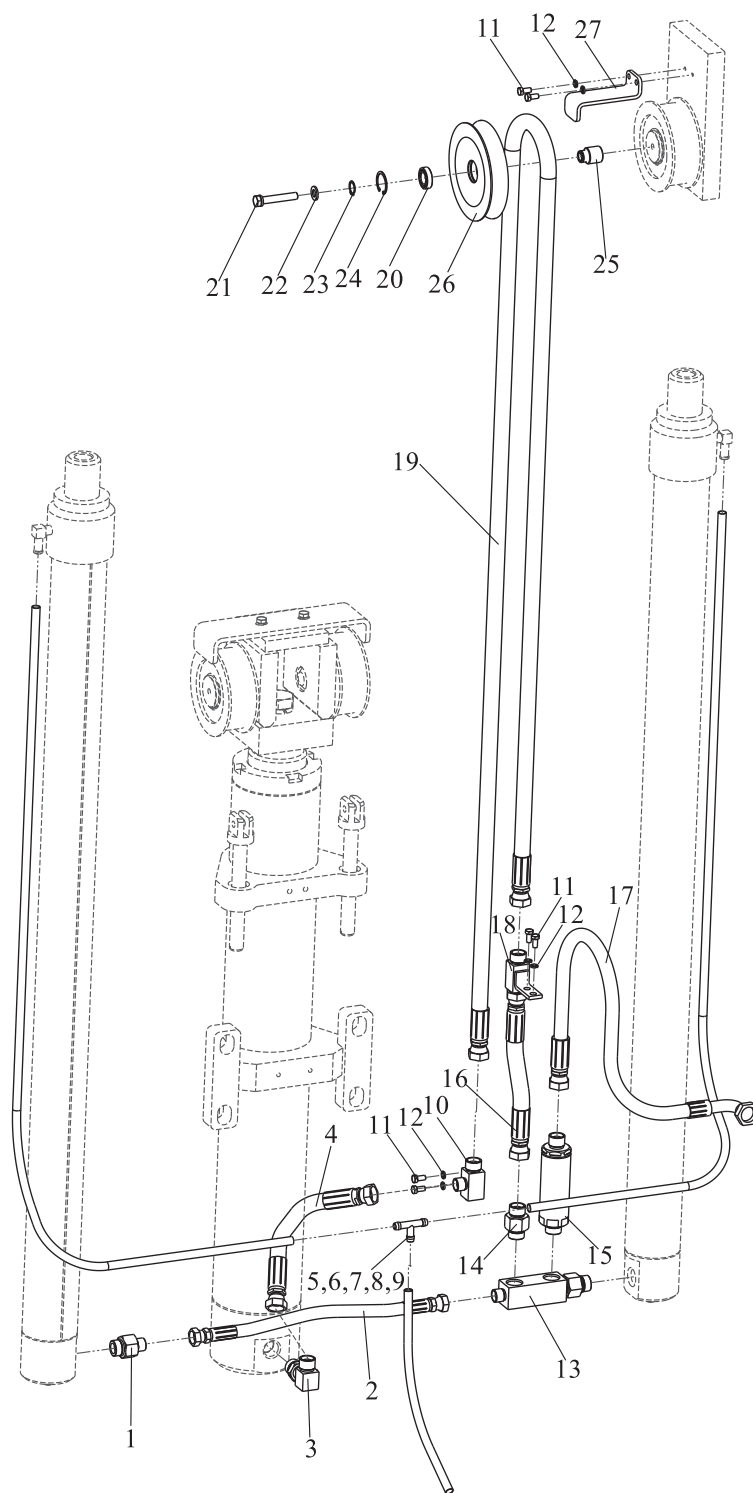

门架管路系统（三节全自由）

Hydraulic system mast(Full Free 3-Stage Mast KZM)

序号 Item	零件号 Part No	零部件名称 Description	数量 Q'ty	备注 Remark
20	GB/T276	轴承61904-2Z(37×20×8) Bushing	1	
21	GB/T5783	螺栓M12×70 Bolt	1	
22	GB/T93	弹垫 12 Washer,lock	1	
23	GB/T894.1	轴用弹性挡圈 20 Snap ring	1	
24	GB/T893.1	孔用弹性挡圈 37 Snap ring	1	
25	S70B3-70002	轴头 Spindle head	1	
26	S70B3-70001	滑轮 Pulley	1	
27	S70B3-70003	挡链板 Plate	1	

门架管路系统（三节全自由）
Hydraulic system mast(Full Free 3-Stage Mast KZM)

管路系统选用件（Mast Piping Optional Parts）			
起升高度 Lifting Height	件7代号 Part No	件19长度 Hose(mm)	备注 Remark
3600	TGIBII-16255*J	2550	
4000	TGIBII-16285*J	2850	
4350	TGIBII-16305*J	3050	
4500	TGIBII-16315*J	3150	
4800	TGIBII-16335*J	3350	
5000	TGIBII-16350*J	3500	
5500	TGIBII-16385*J	3850	
6000	TGIBII-16415*J	4150	

货叉
Fork

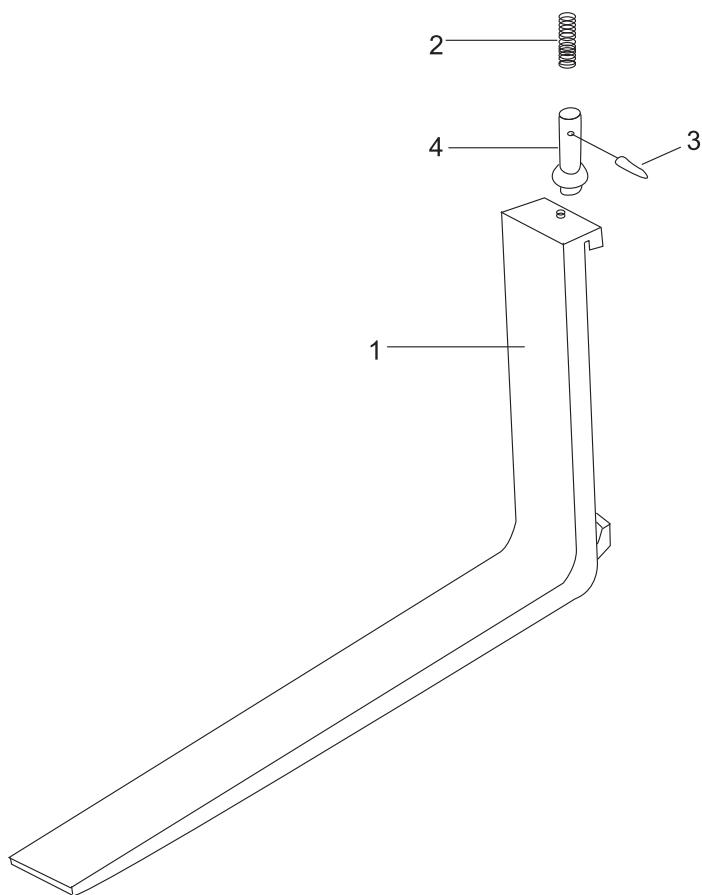

货叉
Fork

序号 Item	零件号 Part No	零部件名称 Description	数量 Q'ty	备注 Remark
1	A50A3-90000	货叉总成 Lifting fork ass'y	2	5-6t
-	A70A3-90000	货叉总成 Lifting fork ass'y	2	7-8t
2	A50A3-90001	弹簧 Spring	2	5-6t
-	A70A3-90001	弹簧 Spring	2	7-8t
3	A50A3-90002	销 Pin	2	5-6t
-	A70A3-90002	销 Pin	2	7-8t
4	A50A3-90003	止动销子 Pin, stopper	2	5-6t
-	A70A3-90003	止动销子 Pin, stopper	2	7-8t

货叉架（基本型）
Lift Bracket(Normal mast KM)

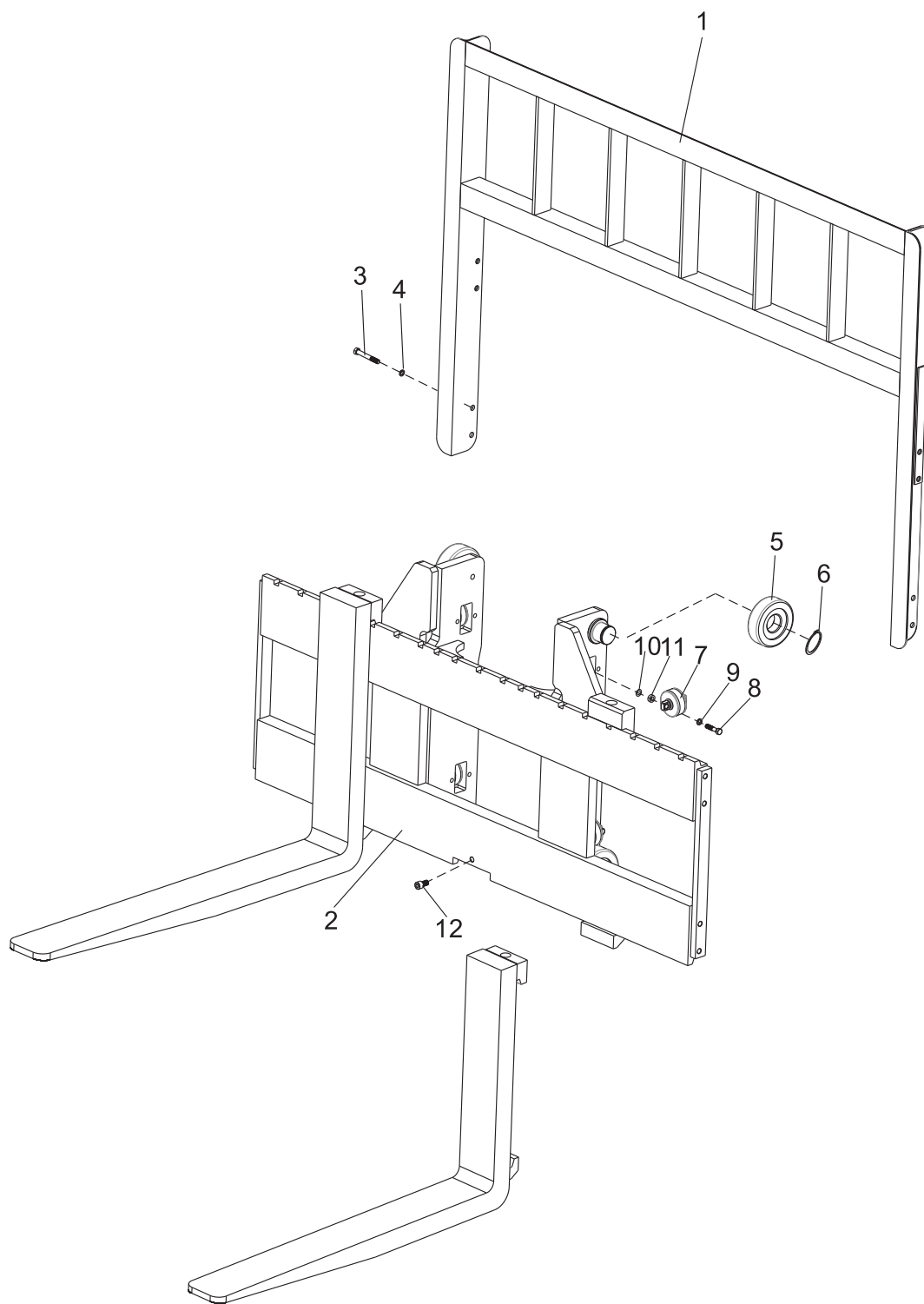

货叉架（基本型）

Lift Bracket(Normal mast KM)

序号 Item	零件号 Part No	零部件名称 Description	数量 Q'ty	备注 Remark
1	M50A3-60000	挡货架总成 Backrest ass'y	1	
2	M50B3-50000	货叉架总成 Lift bracket ass'y	1	5-6t
-	M70B3-50000	货叉架总成 Lift bracket ass'y	1	7-8t
3	GB/T5786	螺栓M14×1.5×30 Bolt	8	
4	GB/T93	弹垫14 Washer, lock	8	
5	M50B3-40200	主滚轮 End Roller	4	5-6t
-	M50A3-40200	主滚轮 End Roller	6	7-8t
6	GB/T894.1	弹性挡圈55 Snap,ring	4	5-6t
-	GB/T894.1	弹性挡圈55 Snap,ring	6	7-8t
7	M50A3-40300	侧滚轮组 Side Roller	4	
8	GB/T5783	螺栓M12×1.5×55 Bolt	8	
9	GB/T93	弹垫12 Washer, lock	8	
10	M50A3-40003	垫圈 Washer	8	
11	M50A3-40004	垫块 Spacer	8	
12	GB/T70.1	内六角圆柱头螺钉 M14×20 Screw	1	

货叉架（两节全自由）
Lift Bracke(Full Free 2-Stage Mast KZM)

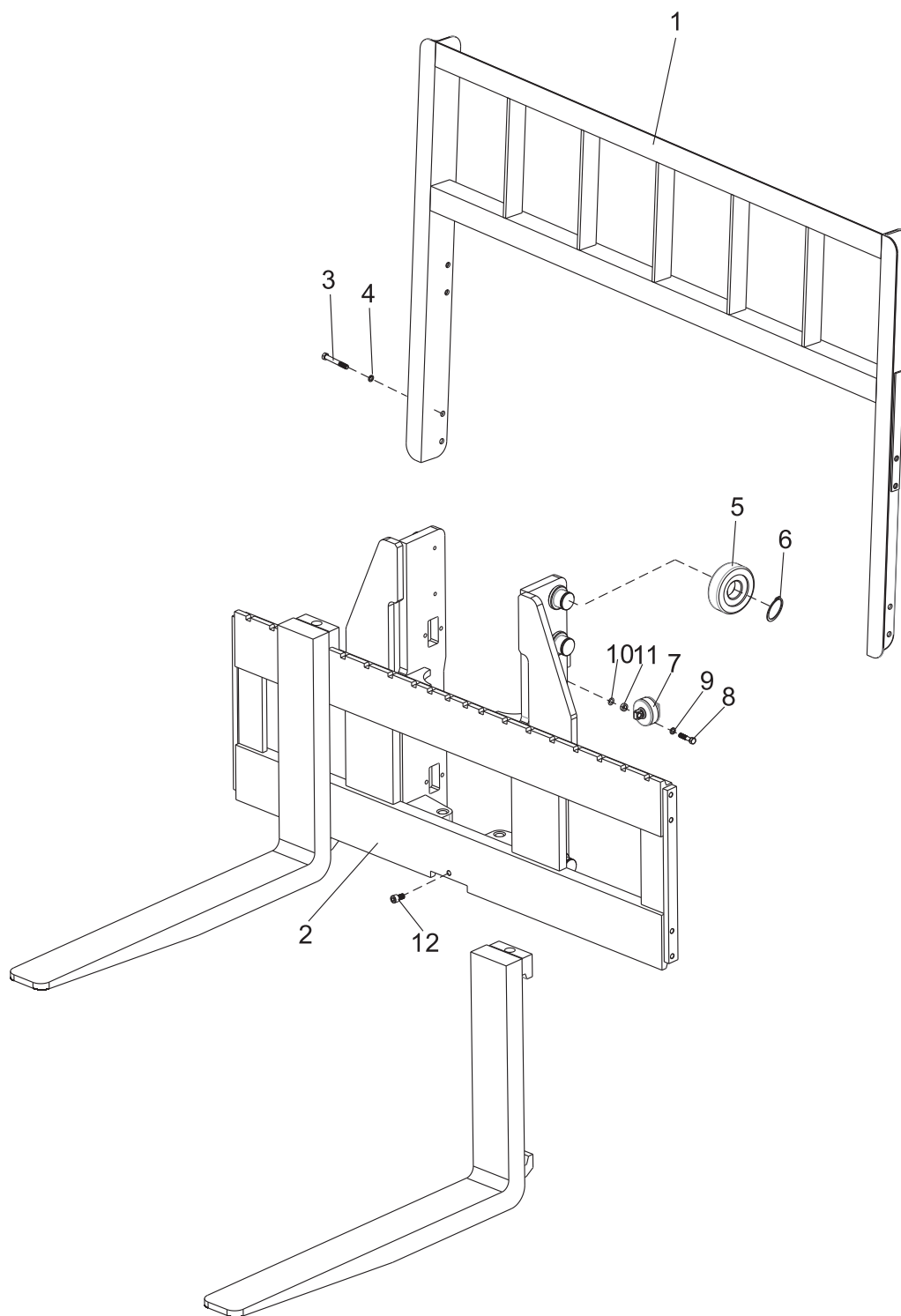

货叉架（两节全自由）

Lift Bracke(Full Free 2-Stage Mast KZM)

序号 Item	零件号 Part No	零部件名称 Description	数量 Q'ty	备注 Remark
1	M50A3-60000	挡货架总成 Backrest ass'y	1	
2	Z70B3-50000	货叉架总成 Lift bracket ass'y	1	
3	GB/T5786	螺栓M14×1.5×30 Bolt	8	
4	GB/T93	弹垫14 Washer, lock	8	
5	M50A3-40200	主滚轮 End Roller	6	
6	GB/T894.1	弹性挡圈55 Snap,ring	6	
7	M50A3-40300	侧滚轮组 Side Roller	4	
8	GB/T5783	螺栓M12×1.5×55 Bolt	8	
9	GB/T93	弹垫12 Washer, lock	8	
10	M50A3-40003	垫圈 Washer	8	
11	M50A3-40004	垫块 Spacer	8	
12	GB/T70.1	内六角圆柱头螺钉 M14×20 Screw	1	

货叉架（三节全自由）
Lift Bracket(Full Free 3-Stage Mast KZM)

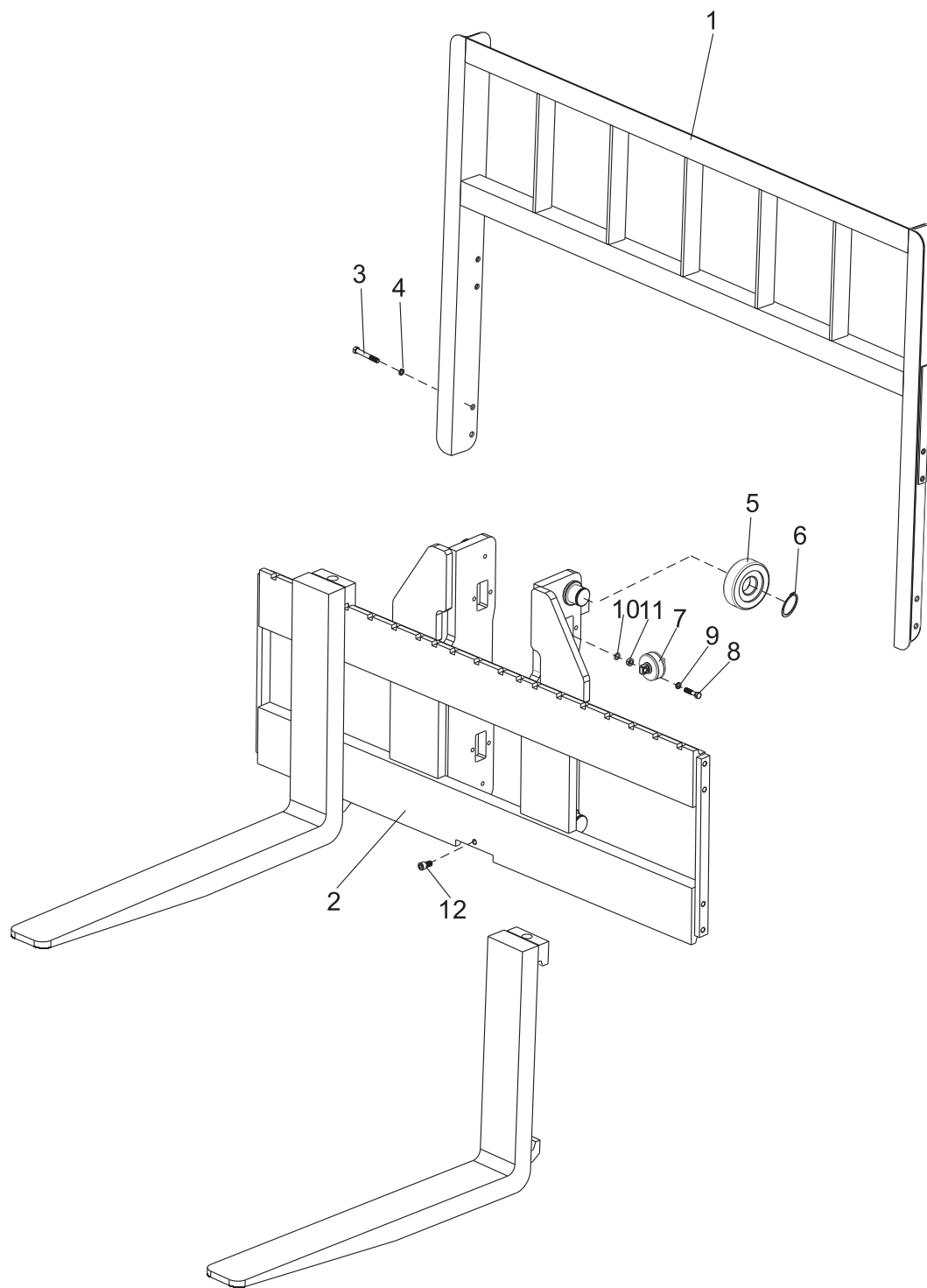

货叉架（三节全自由）

Lift Bracket(Full Free 3-Stage Mast KZM)

序号 Item	零件号 Part No	零部件名称 Description	数量 Q'ty	备注 Remark
1	M50A3-60000	挡货架总成 Backrest ass'y	1	
2	S50B3-50000	货叉架总成 Lift bracket ass'y	1	5-6t
-	S70B3-50000	货叉架总成 Lift bracket ass'y	1	7-8t
3	GB/T5786	螺栓M14×1.5×30 Bolt	8	
4	GB/T93	弹垫14 Washer, lock	8	
5	M50B3-40200	主滚轮 End Roller	4	5-6t
-	M50A3-40200	主滚轮 End Roller	6	7-8t
6	GB/T894.1	弹性挡圈55 Snap,ring	4	5-6t
-	GB/T894.1	弹性挡圈55 Snap,ring	6	7-8t
7	M50A3-40300	侧滚轮组 Side Roller	4	
8	GB/T5783	螺栓M12×1.5×55 Bolt	8	
9	GB/T93	弹垫12 Washer, lock	8	
10	M50A3-40003	垫圈 Washer	8	
11	M50A3-40004	垫块 Spacer	8	
12	GB/T70.1	内六角圆柱头螺钉 M14×20 Screw	1	

门架（基本型）
Mast(Normal mast KM)

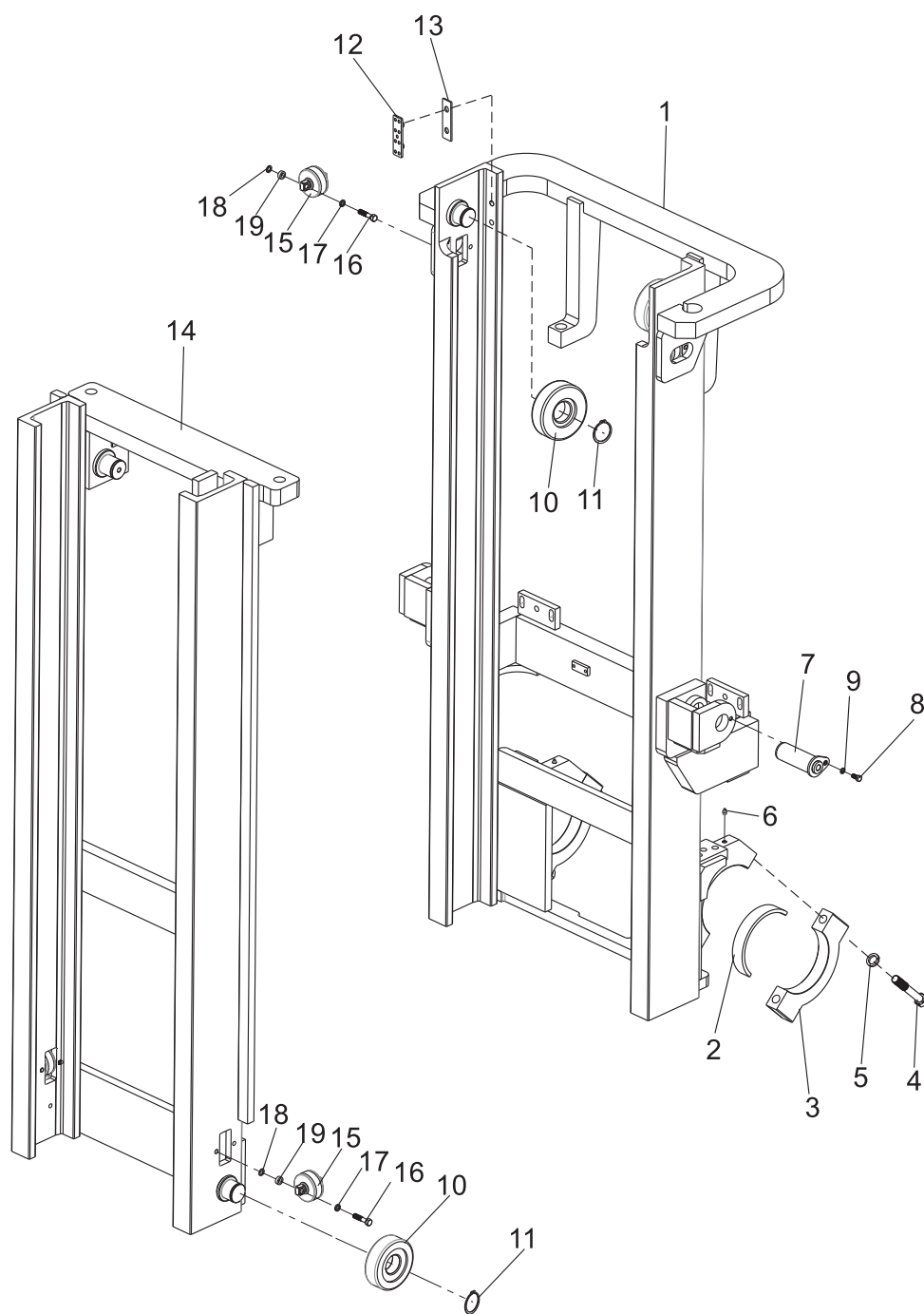

门架（基本型）
Mast(Normal mast KM)

序号 Item	零件号 Part No	零部件名称 Description	数量 Q'ty	备注 Remark
1	M50B3-10000	外门架 Outer master	1	5-6t
-	M70B3-10000	外门架 Outer master	1	7-8t
2	M50A3-00002	轴衬 Bushing	2	
3	M50A3-00001	支座盖 Cap	2	
4	GB/T5782	螺栓M22×1.5×140 Bolt	4	
5	GB/T93	弹垫22 Washer,lock	4	
6	JB/T7940.1	直通式压注油杯M10×1 Fitting	2	
7	M50A3-00100	倾斜油缸销轴总成 Pin axle ass'y	2	
8	GB/T5786	螺栓M10×1.25×20 Bolt	2	
9	GB/T93	弹垫10 Washer,lock	2	
10	M50B3-40200	主滚轮 End Roller	4	5-6t
-	M50A3-40200	主滚轮 End Roller	4	7-8t
11	GB/T894.1	弹性挡圈55 Snap ring	4	
12	M50A3-40005	限位滑块 Slipper	2	
13	M50A3-40006	调整垫片I Shim	6	
14	M50B3-30000	内门架 Inner master	1	5-6t
-	M70B3-30000	内门架 Inner master	1	7-8t
15	M50A3-40300	侧滚轮组 Side roller	4	
16	GB/T5783	螺栓M12×1.25×55 Bolt	8	
17	GB/T93	弹垫12 Washer,lock	8	
18	M50A3-40003	垫圈 Washer	8	
19	M50A3-40004	垫块 Spacer	8	

门架（两节全自由） Mast(Full Free 2-Stage Mast KZM)

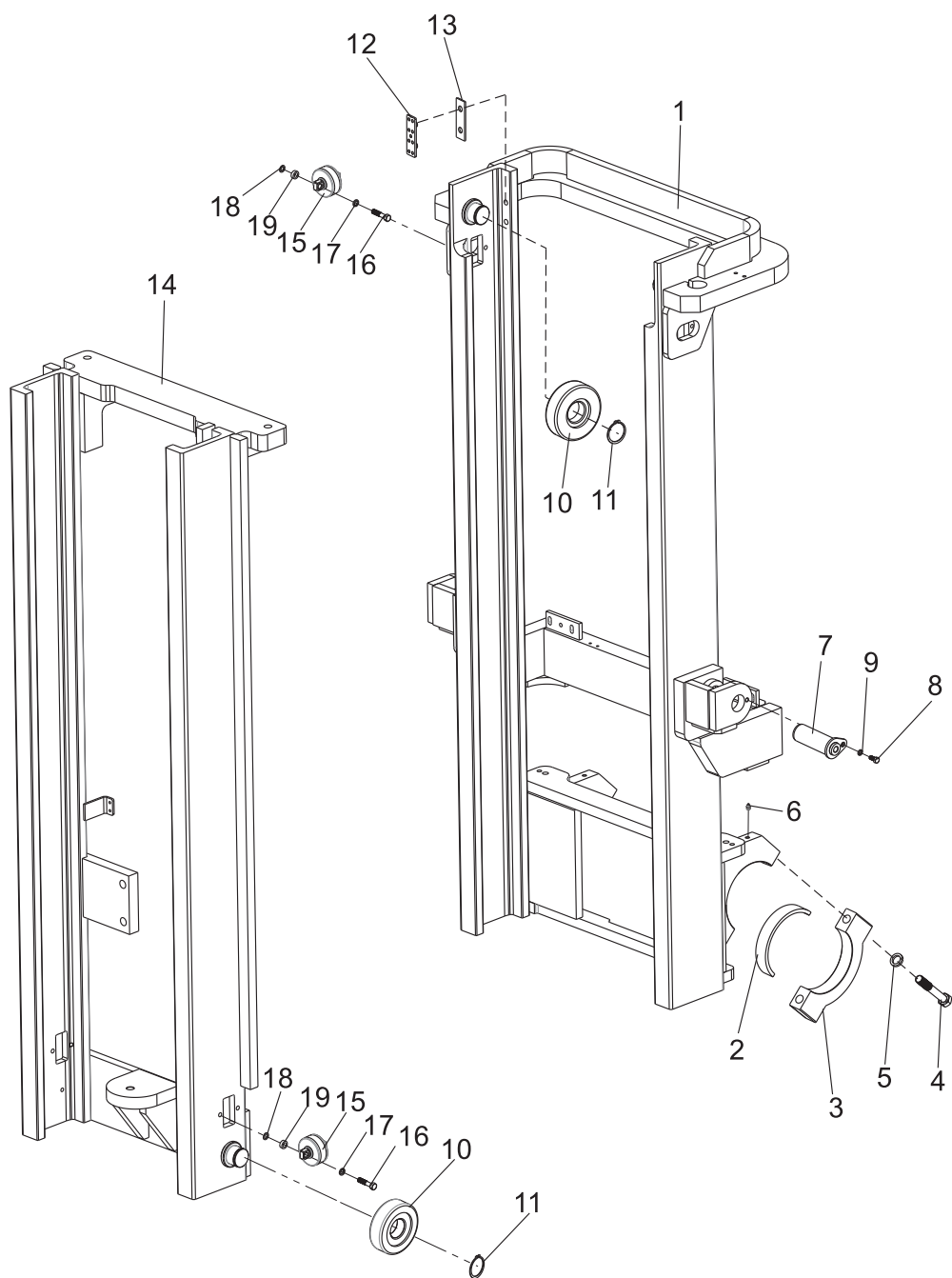

门架（两节全自由）
Mast(Full Free 2-Stage Mast KZM)

序号 Item	零件号 Part No	零部件名称 Description	数量 Q'ty	备注 Remark
1	Z70B3-10000	外门架 Outer master	1	
2	M50A3-00002	轴衬 Bushing	2	
3	M50A3-00001	支座盖 Cap	2	
4	GB/T5782	螺栓M22×1.5×140 Bolt	4	
5	GB/T93	弹垫22 Washer,lock	4	
6	JB/T7940.1	直通式压注油杯M10×1 Fitting	2	
7	M50A3-00100	倾斜油缸销轴总成 Pin axle ass'y	2	
8	GB/T5786	螺栓M10×1.25×20 Bolt	2	
9	GB/T93	弹垫10 Washer,lock	2	
10	M50A3-40200	主滚轮 End Roller	4	
11	GB/T894.1	弹性挡圈55 Snap ring	4	
12	M50A3-40005	限位滑块 Slipper	2	
13	M50A3-40006	调整垫片I Shim	6	
14	Z70B3-30000	内门架 Inner master	1	
15	M50A3-40300	侧滚轮组 Side roller	4	
16	GB/T5783	螺栓M12×1.25×55 Bolt	8	
17	GB/T93	弹垫12 Washer,lock	8	
18	M50A3-40003	垫圈 Washer	8	
19	M50A3-40004	垫块 Spacer	8	

门架（三节全自由） Mast(Full Free 3-Stage Mast KZM)

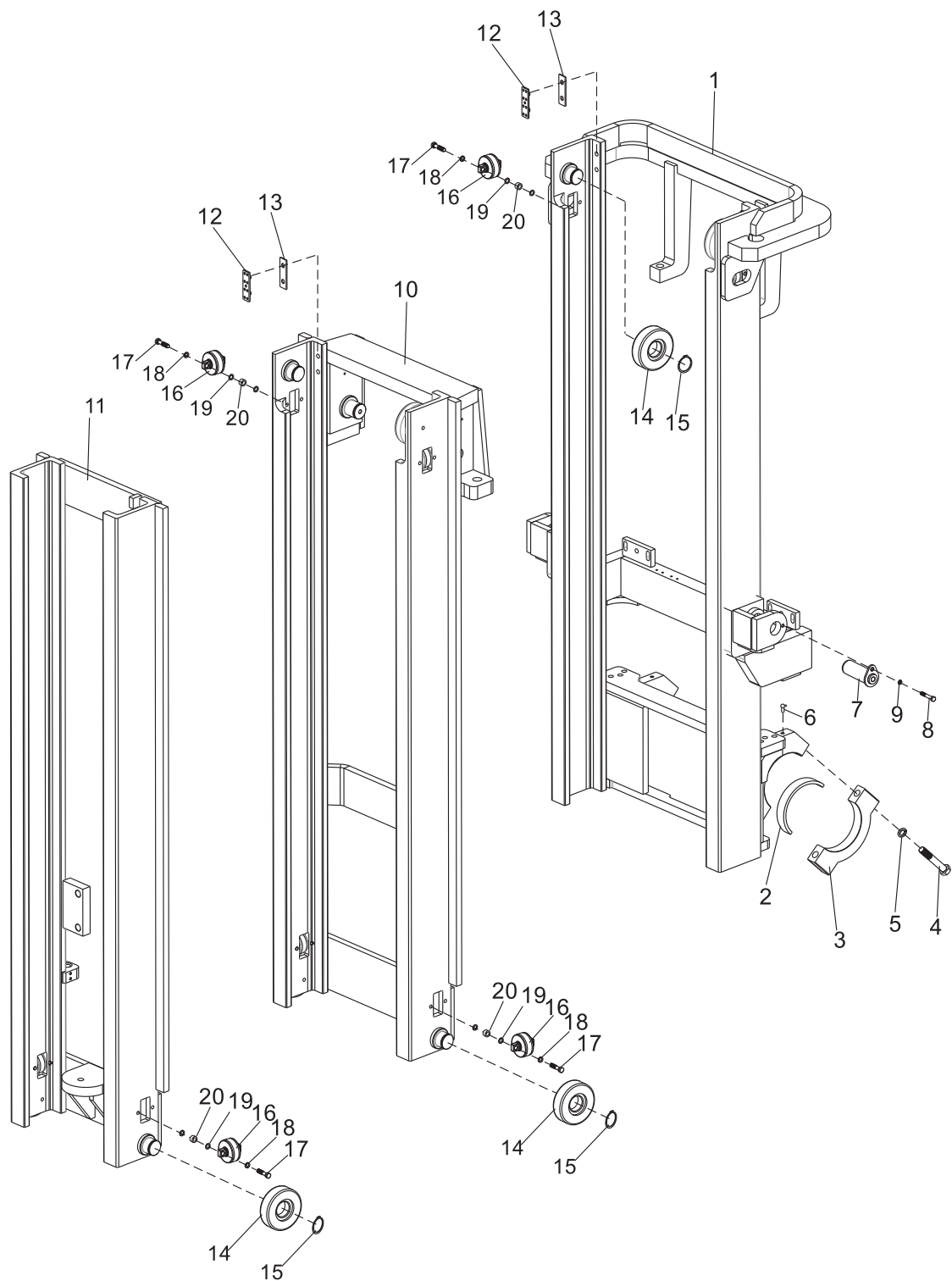

门架（三节全自由）
Mast(Full Free 3-Stage Mast KZM)

序号 Item	零件号 Part No	零部件名称 Description	数量 Q'ty	备注 Remark
1	S50B3-10000	外门架 Outer master	1	5-6t
-	S70B3-10000	外门架 Outer master	1	7-8t
2	M50A3-00002	轴衬 Bushing	2	
3	M50A3-00001	支座盖 Cap	2	
4	GB/T5782	螺栓M22×1.5×140 Bolt	4	
5	GB/T93	弹垫22 Washer,lock	4	
6	JB/T7940.1	直通式压注油杯M10×1 Fitting	2	
7	M50A3-00100	倾斜油缸销轴总成 Pin axle ass'y	2	
8	GB/T5786	螺栓M10×1.25×20 Bolt	2	
9	GB/T93	弹垫10 Washer,lock	2	
10	S50B3-20000	中门架 Medium master	1	5-6t
-	S70B3-20000	中门架 Medium master	1	7-8t
11	S50B3-30000	内门架 Inner master	1	5-6t
-	S50B3-30000	内门架 Inner master	1	7-8t
12	M50A3-40005	限位滑块 Slipper	4	
13	M50A3-40006	调整垫片I Shim	12	
14	M50B3-40200	主滚轮 End Roller	8	5-6t
-	M50A3-40200	主滚轮 End Roller	8	7-8t
15	GB/T894.1	弹性挡圈55 Snap ring	8	
16	M50A3-40300	侧滚轮组 Side roller	8	
17	GB/T5783	螺栓M12×1.25×50 Bolt	16	
18	GB/T93	弹垫12 Washer,lock	16	
19	M50A3-40003	垫圈 Shim	32	
20	M50A3-40004	垫块 Spacer	16	

起升油缸（基本型）

Lift cylinder(Normal mast KM)

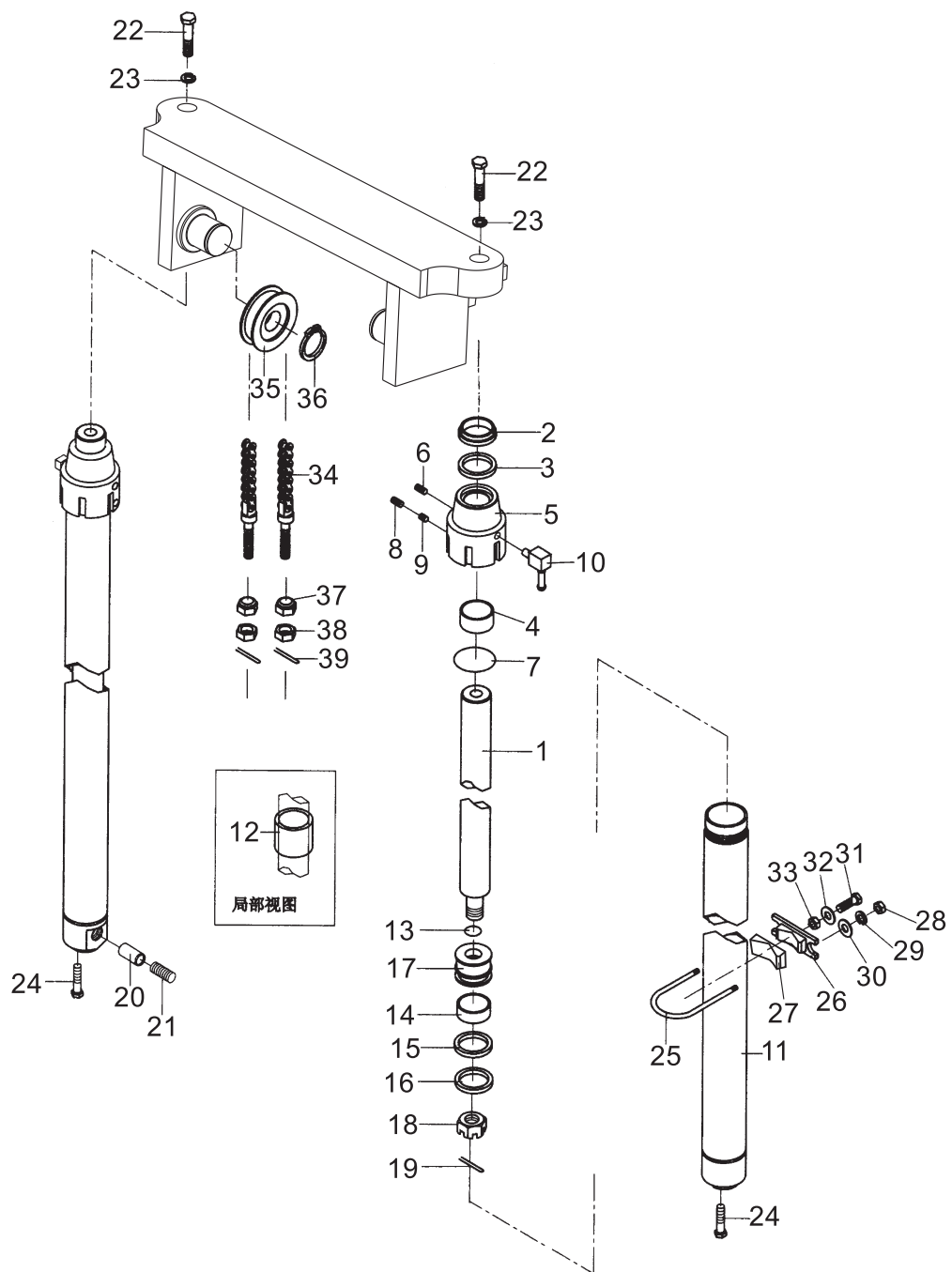

起升油缸（基本型）
Lift cylinder(Normal mast KM)

序号 Item	零件号 Part No	零部件名称 Description	数量 Q'ty	备注 Remark
A	A50A4-10100	起升油缸总成 Lift cylinder ass'y	2	
1	A50A4-10101	活塞杆 Rod	2	
2	A50A4-10102	防尘圈 Seal,dust	2	
3	A50A4-10103	U形密封圈 U-ring	2	
4	A50A4-10104	钢背轴承(6035) Bushing	2	
5	A50A4-10105	缸盖 Cap	2	
6	A50A4-10106	螺塞ZG3/8" Plug	2	
7	GB/T3452.1	O形密封圈92.5×55 O-ring	2	
8	A50A4-10107	塞子 Plug	2	
9	GB/T80	螺钉M6×8 Screw	4	
10	A50A4-10108	管接头 Elbow	2	
11	A50A4-10109	缸体 Cylinder	2	
12	A50A4-10110	调整套 Spacer	见表	
13	A50A4-10111	钢丝挡圈 Ring	2	
14	A50A4-10112	支承环 Wearing	2	
15	A50A4-10113	挡片 Snap ring	2	
16	A50A4-10114	U形密封圈 U-ring	2	
17	A50A4-10115	活塞 Piston	2	
18	A50A4-10116	螺母 Nut	2	
19	GB/T91	销6.3×60 Pin	2	
20	A50A4-10117	滑阀 Piston	2	
21	A50A4-10118	弹簧 Spring	2	
22	GB/T5786	螺栓M30×2×70 Bolt	2	
23	GB/T93	弹垫30 Washer,lock	2	
24	GB/T5786	螺栓M16×1.5×50 Bolt	4	

起升油缸（基本型）

Lift cylinder(Normal mast KM)

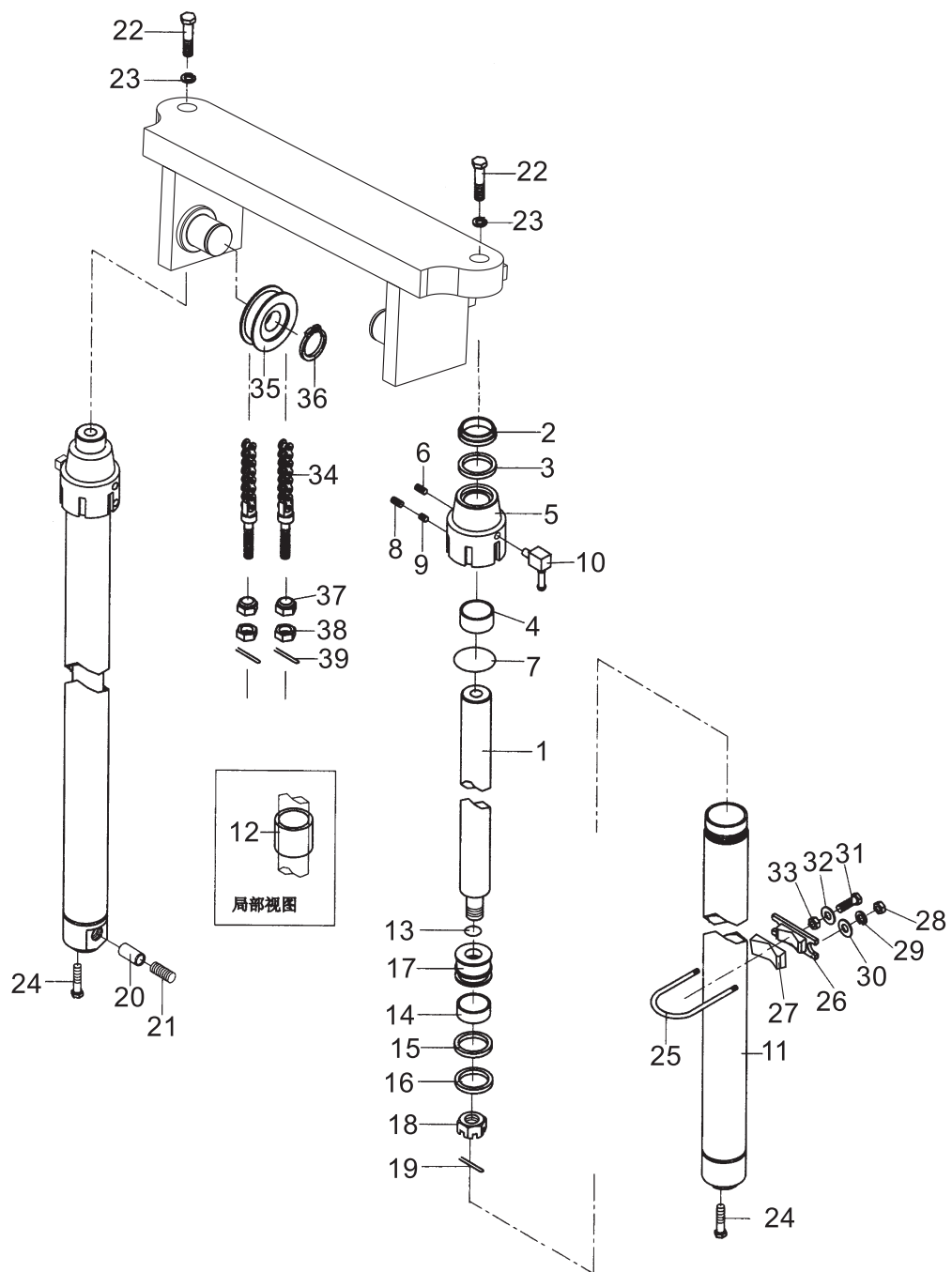

起升油缸（基本型）
Lift cylinder(Normal mast KM)

序号 Item	零件号 Part No	零部件名称 Description	数量 Q'ty	备注 Remark
25	M50A3-80004	U型螺栓 U-bolt	2	
26	M50A3-80003	油缸支撑块 Support	2	
27	M50A3-80002	调整块 Rubber	2	
28	GB/T6171	螺母M12×1.25 Nut	4	
29	GB/T93	弹垫12 Washer,lock	4	
30	GB/T97.1	平垫12 Washer	4	
31	GB/T5786	螺栓M16×1.25×65 Bolt	2	
32	GB/T97.1	平垫16 Washer	2	
33	GB/T6171	螺母M16×1.5 Nut	2	
34	LH2044×N	链条总成 Chain	2	
35	M50A3-80100	链轮总成 Sheave	2	
36	GB/T894.1	挡圈55 Snap ring	2	
37	GB/T6171	螺母M24×2 Nut	2	
38	A50A4-10119	球形螺母 Nut	4	
39	GB/T91	销3.2×40 Pin	4	

前起升油缸（两节全自由） Front Lift cylinder(Full Free 2-Stage Mast KZM)

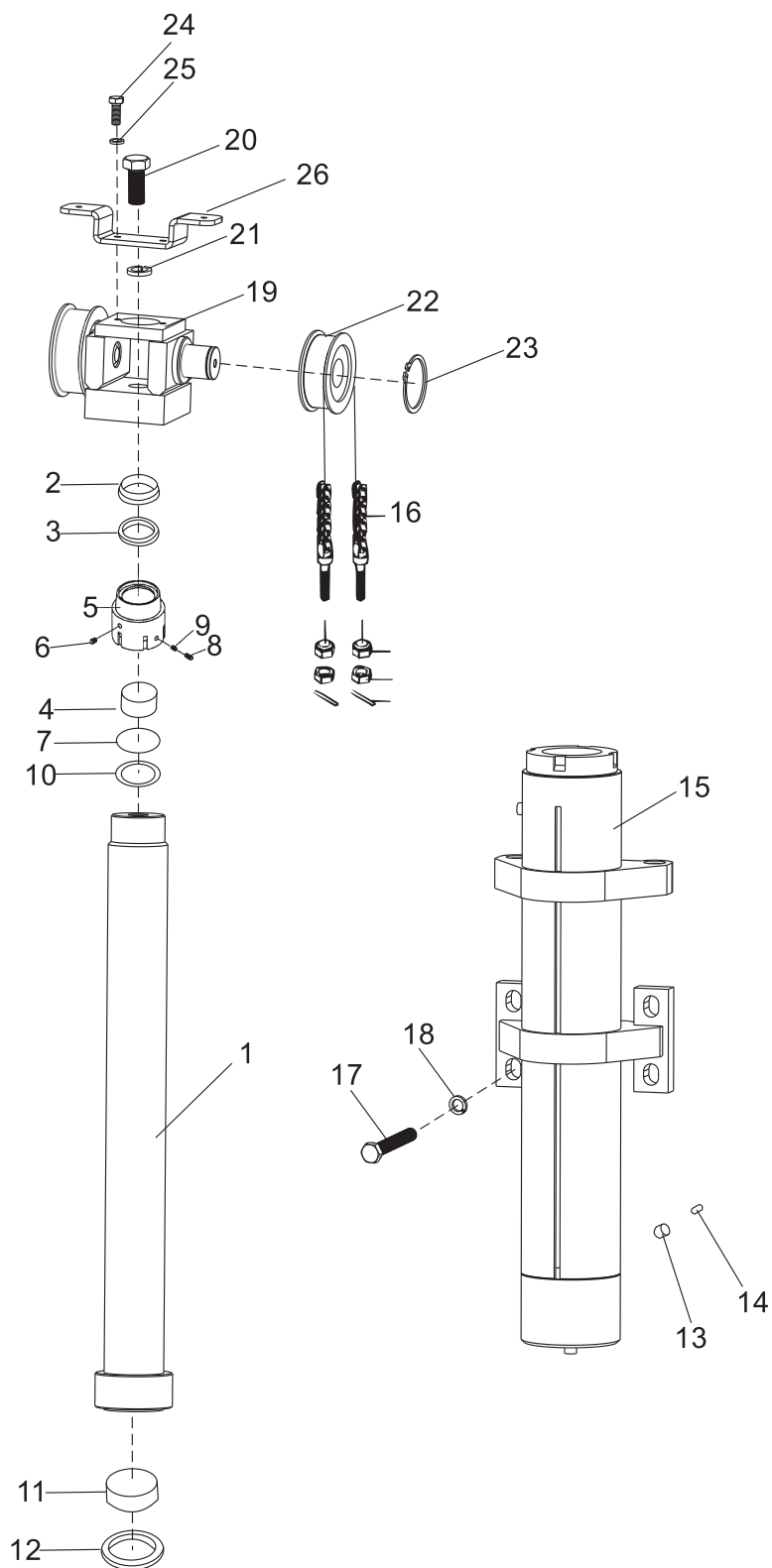

前起升油缸（两节全自由）
Front Lift cylinder(Full Free 2-Stage Mast KZM)

序号 Item	零件号 Part No	零部件名称 Description	数量 Q'ty	备注 Remark
A	A50B4-10300	前起升油缸总成 Front lift cylinder ass'y	1	
1	A50B4-10301	活塞杆 Rod	1	
2	A50A4-10302	防尘圈 Seal,dust	1	
3	A50A4-10303	轴封100×115×9 Ring	1	
4	A50A4-10304	钢背轴承 Bushing	1	
5	A50A4-10305	缸盖 Cap	1	
6	A50A4-10306	螺塞ZG3/8" Plug	1	
7	GB/T3452.1	O形密封圈130×3.1 O-ring	1	
8	A50A4-10307	塞子 Plug	1	
9	GB/T80	螺钉M6×8 Screw	2	
10	A50A4-10308	挡圈115×130×3 Ring	1	
11	A50A4-10309	孔用支承环130×30×3 Wearing	1	
12	A50A4-10310	孔封130×115×9 Ring	1	
13	A50A4-10311	滑阀 Piston	1	
14	A50A4-10312	弹簧 Spring	1	
15	A50B4-10302	缸体 Cylinder	1	
16	LH2044×N	链条总成 Chain	2	
17	GB/T5786	螺栓M24×2×65 Bolt	4	
18	GB/T93	弹垫24 Washer,lock	4	
19	Z70B3-80100	缸头座总成 Sprocket seat ass'y	1	
20	GB/T5786	螺栓M30×2×80 Bolt	1	
21	GB/T93	弹垫30 Washer,lock	1	
22	M50A3-80100	链轮总成 Sheave	2	
23	GB/T894.1	挡圈55 Snap ring	2	
24	GB/T5783	螺栓M10×20 Bolt	2	
25	GB/T93	弹垫10 Washer,lock	2	
26	Z70B3-80001	链条挡板 Chain baffle	1	

前起升油缸(三节全自由) Front Lift Cylinder (Full Free 3-Stage Mast KZM)

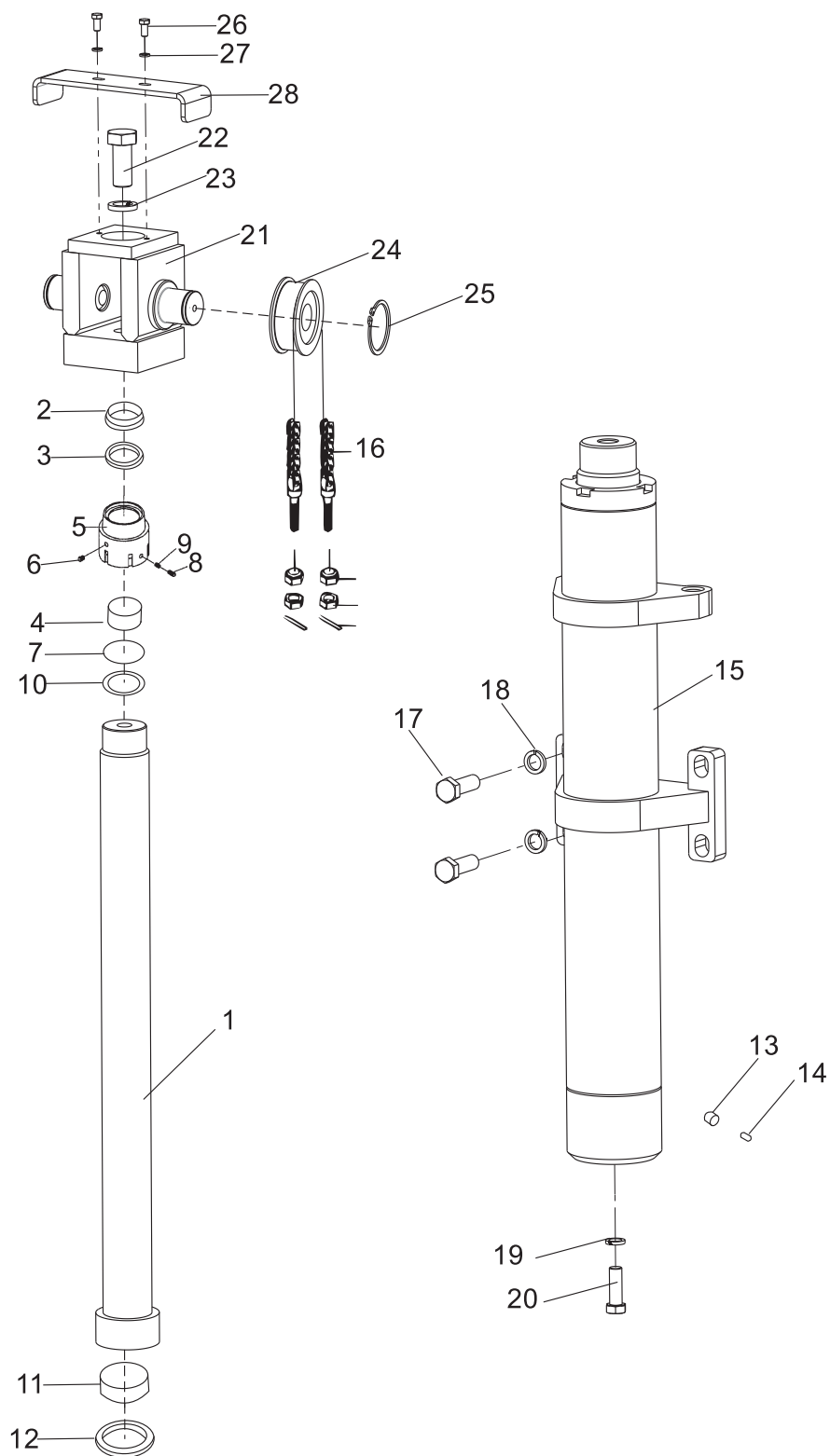

前起升油缸(三节全自由)
Front Lift Cylinder (Full Free 3-Stage Mast KZM)

序号 Item	零件号 Part No	零部件名称 Description	数量 Q'ty	备注 Remark
A	A50B4-10500	前起升油缸总成 Front lift cylinder ass'y	1	
1	A50B4-10501	活塞杆 Rod	1	
2	A50A4-10302	防尘圈 Seal,dust	1	
3	A50A4-10303	轴封100×115×9 Ring	1	
4	A50A4-10304	钢背轴承 Bushing	1	
5	A50A4-10305	缸盖 Cap	1	
6	A50A4-10306	螺塞ZG3/8" Plug	1	
7	GB/T3452.1	O形密封圈130×3.1 O-ring	1	
8	A50A4-10307	塞子 Plug	1	
9	GB/T80	螺钉M6×8 Screw	2	
10	A50A4-10308	挡圈115×130×3 Ring	1	
11	A50A4-10309	孔用支承环130×30×3 Wearing	1	
12	A50A4-10310	孔封130×115×9 Ring	1	
13	A50A4-10311	滑阀 Piston	1	
14	A50A4-10312	弹簧 Spring	1	
15	A50B4-10502	缸体 Cylinder	1	
16	LH2044×N	链条总成 Chain	2	
17	GB/T5786	螺栓M24×2×70 Bolt	4	
18	GB/T93	弹垫24 Washer,lock	4	
19	GB/T5786	螺栓M20×1.5×55 Bolt	1	
20	GB/T93	弹垫20 Washer,lock	1	
21	S70B3-80100	缸头座总成 Sprocket seat ass'y	1	
22	GB/T5786	螺栓M30×2×60 Bolt	1	
23	GB/T93	弹垫30 Washer,lock	1	
24	M50A3-80100	链轮总成 Sheave	2	
25	GB/T894.1	挡圈55 Snap ring	2	
26	GB/T5783	螺栓M10×20 Bolt	2	
27	GB/T93	弹垫10 Washer,lock	2	
28	S70B3-80002	链条挡板 Chain baffle	1	

后起升油缸(两节全自由) Rear Lift Cylinder (Full Free 2-Stage Mast KZM)

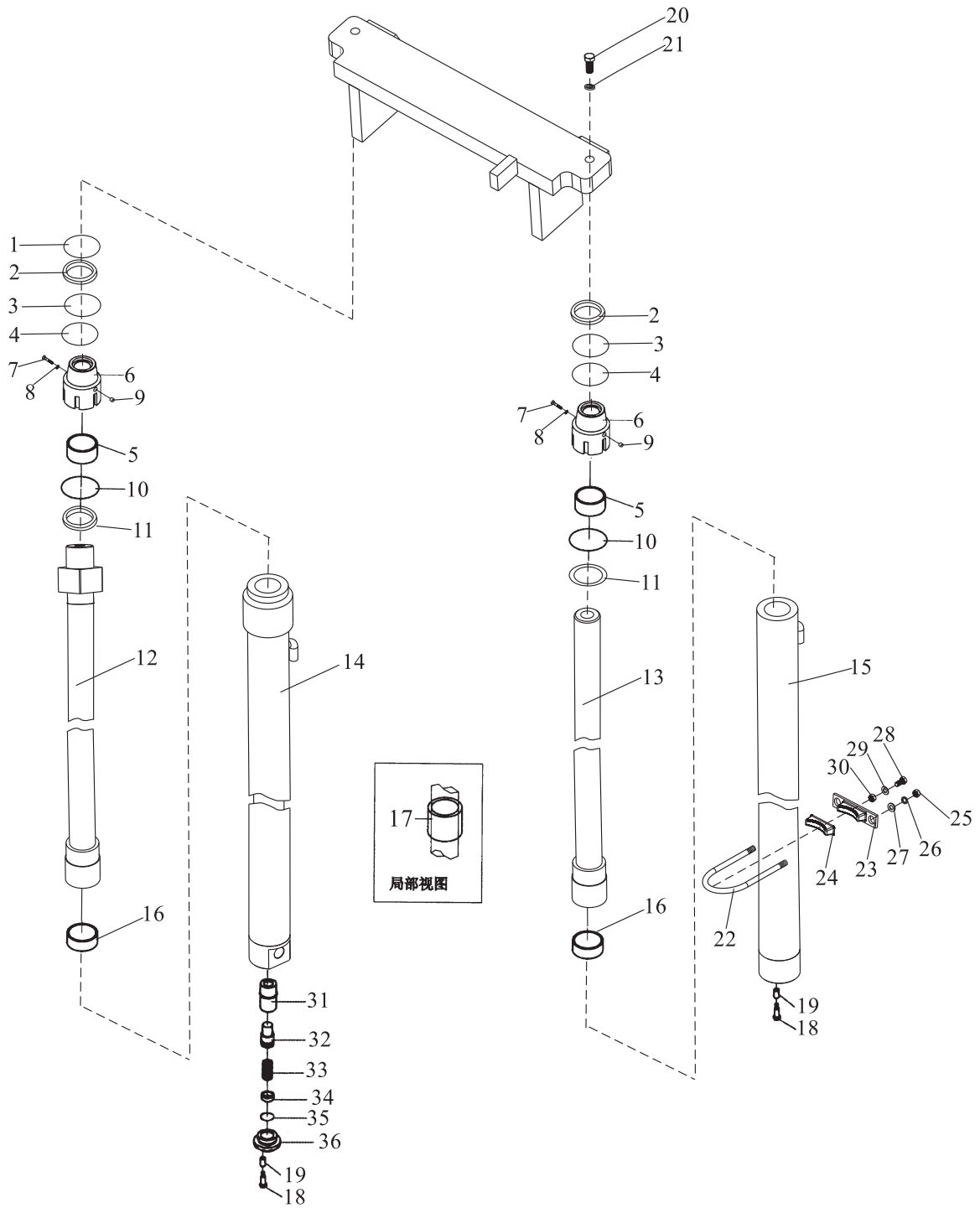

后起升油缸(两节全自由)
Rear Lift Cylinder (Full Free 2-Stage Mast KZM)

序号 Item	零件号 Part No	零部件名称 Description	数量 Q'ty	备注 Remark
A	A50B4-10400	后起升油缸总成 Rear lift cylinder ass'y	2	
1	GB/T1235	O型密封圈45×3.1 O-ring	1	
2	A50A4-10401	防尘圈 Dust ring	2	
3	A50A4-10402	挡圈60×70×3 Ring, back up	2	
4	A50A4-10403	轴用密封圈60×70×6 Ring	2	
5	A50A4-10404	钢背轴承65×60×35 Guide bushing	2	
6	A50A4-10405	缸盖 Cap, lift cylinder	2	
7	GB/T70	内六角螺钉M8×20 Screw	4	
8	JB/T982	组合密封垫8 Gasket	2	
9	A50A4-10406	放气堵M8 Plug	2	
10	GB/T1235	O型密封圈80×3.1 O-ring	2	
11	A50A4-10407	挡圈75.2×80×1.5 Ring, back up	2	
12	A50B4-10403	右活塞杆 Piston rod R.H.	1	
13	A50B4-10404	左活塞杆 Piston rod L.H.	1	
14	A50B4-10401	右缸体 Cylinder R.H.	1	
15	A50B4-10402	左缸体 Cylinder L.H.	1	
16	A50A4-10410	孔用支承环80×25×2.5 Backup ring	2	
17	A50A4-10413	调整套 Spacer	见表	
18	GB/T5786	螺栓M12×1.25×35 Bolt	2	
19	GB/T93	弹垫12 Washer,lock	2	
20	GB/T5786	螺栓M20×1.5×60 Bolt	2	
21	GB/T93	弹垫20 Washer,lock	2	
22	M35A3-80001	U型螺栓 U-bolt	2	
23	M30A3-80003	油缸支撑块 Support	2	
24	M30A3-80002	调整块 Rubber	2	
25	GB/T6171	螺母M10×1.25 Nut	4	

后起升油缸(两节全自由) Rear Lift Cylinder (Full Free 2-Stage Mast KZM)

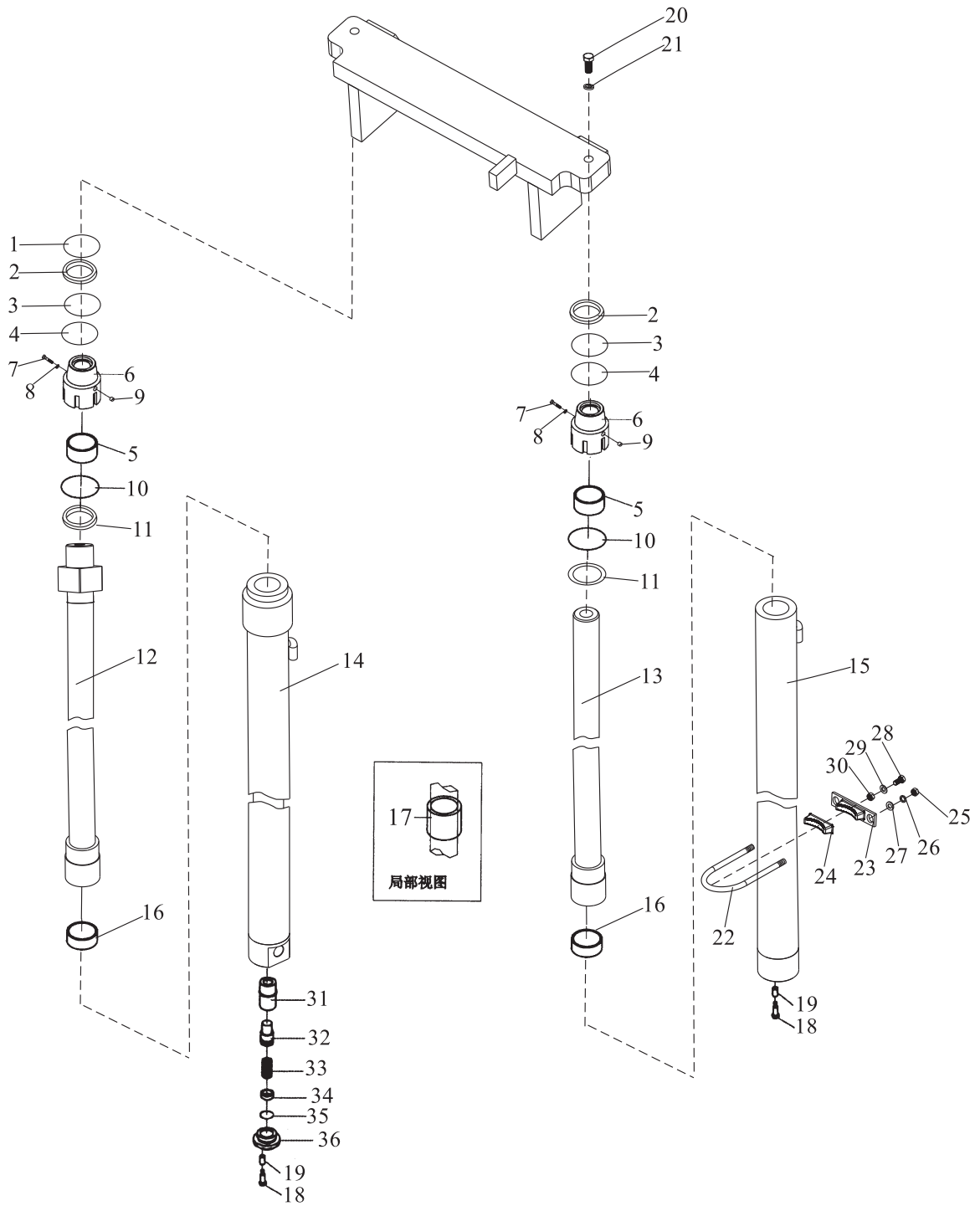

后起升油缸(两节全自由)

Rear Lift Cylinder (Full Free 2-Stage Mast KZM)

序号 Item	零件号 Part No	零部件名称 Description	数量 Q'ty	备注 Remark
26	GB/T93	弹垫10 Washer,lock	4	
27	GB/T97.1	平垫10 Washer	4	
28	GB/T5786	螺栓M12×1.25×35 Bolt	2	
29	GB/T97.1	平垫12 Washer	2	
30	GB/T6171	螺母M12×1.25 Nut	2	
31	A50A4-10414	阀帽 Sleeve	1	
32	A50A4-10415	阀芯 Spool	1	
33	A50A4-10416	弹簧 Spring	1	
34	A50A4-10417	阀座 Seat	1	
35	GB/T3452.1	O型密封圈30×2.65 O-ring	1	
36	A50B4-10405	底盖 Seat, valve	1	

后起升油缸(三节全自由) Rear Lift Cylinder (Full Free 3-Stage Mast KZM)

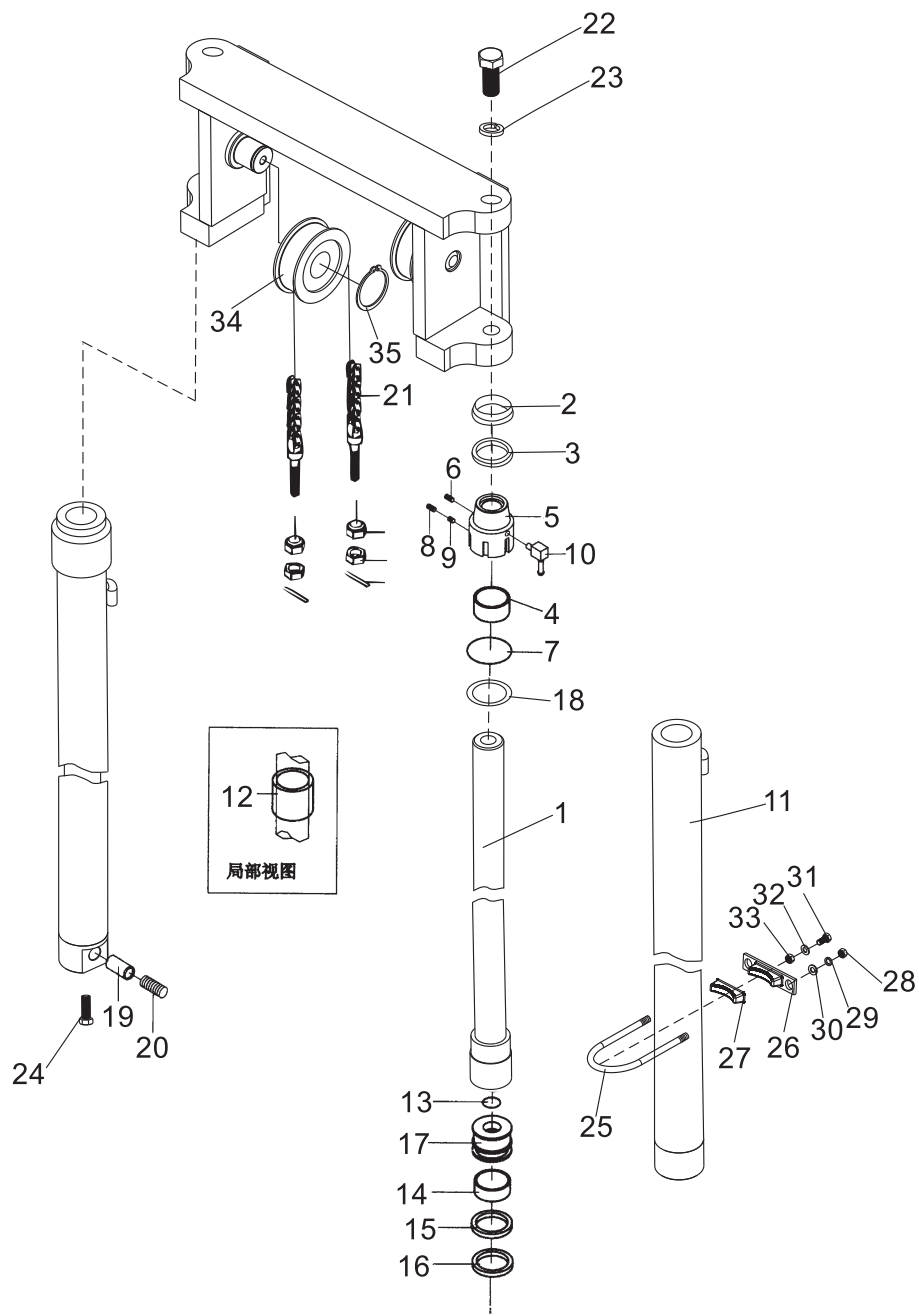

后起升油缸(三节全自由)
Rear Lift Cylinder (Full Free 3-Stage Mast KZM)

序号 Item	零件号 Part No	零部件名称 Description	数量 Q'ty	备注 Remark
A	A50B4-10600	后起升油缸总成 Rear lift cylinder ass'y	2	
1	A50B4-10601	活塞杆 Rod	2	
2	A50A4-10602	防尘圈 Seal,dust	2	
3	A50A4-10603	轴封60×70×6 Ring	2	
4	A50A4-10604	钢背轴承(6045) Bushing	2	
5	A50A4-10605	缸盖 Cap	2	
6	A50A4-10606	螺塞ZG3/8" Plug	2	
7	GB/T3452.1	O形密封圈106×3.55 O-ring	2	
8	A50A4-10607	塞子 Plug	2	
9	GB/T80	螺钉M6×8 Screw	4	
10	A50A4-10608	管接头 Elbow	2	
11	A50B4-10602	缸体 Cylinder	2	
12	A50A4-10610	调整套 Spacer	见表	
13	A50A4-10611	钢丝挡圈 Ring	2	
14	A50A4-10612	支承环80×25×2.5 Wearing	2	
15	A50A4-10613	挡圈70×80×3 Ring	2	
16	A50A4-10614	孔封80×70×6 Ring	2	
17	A50A4-10615	活塞 Piston	2	
18	A50A4-10616	挡圈60×70×3 Ring	2	
19	A50A4-10617	滑阀 Rotary	2	
20	A50A4-10618	弹簧 Spring	2	
21	LH2044×N	链条总成 Chain	2	
22	GB/T5786	螺栓M30×2×70 Bolt	2	
23	GB/T93	弹垫30 Washer,lock	2	
24	GB/T5786	螺栓M16×1.5×50 Bolt	2	

后起升油缸(三节全自由) Rear Lift Cylinder (Full Free 3-Stage Mast KZM)

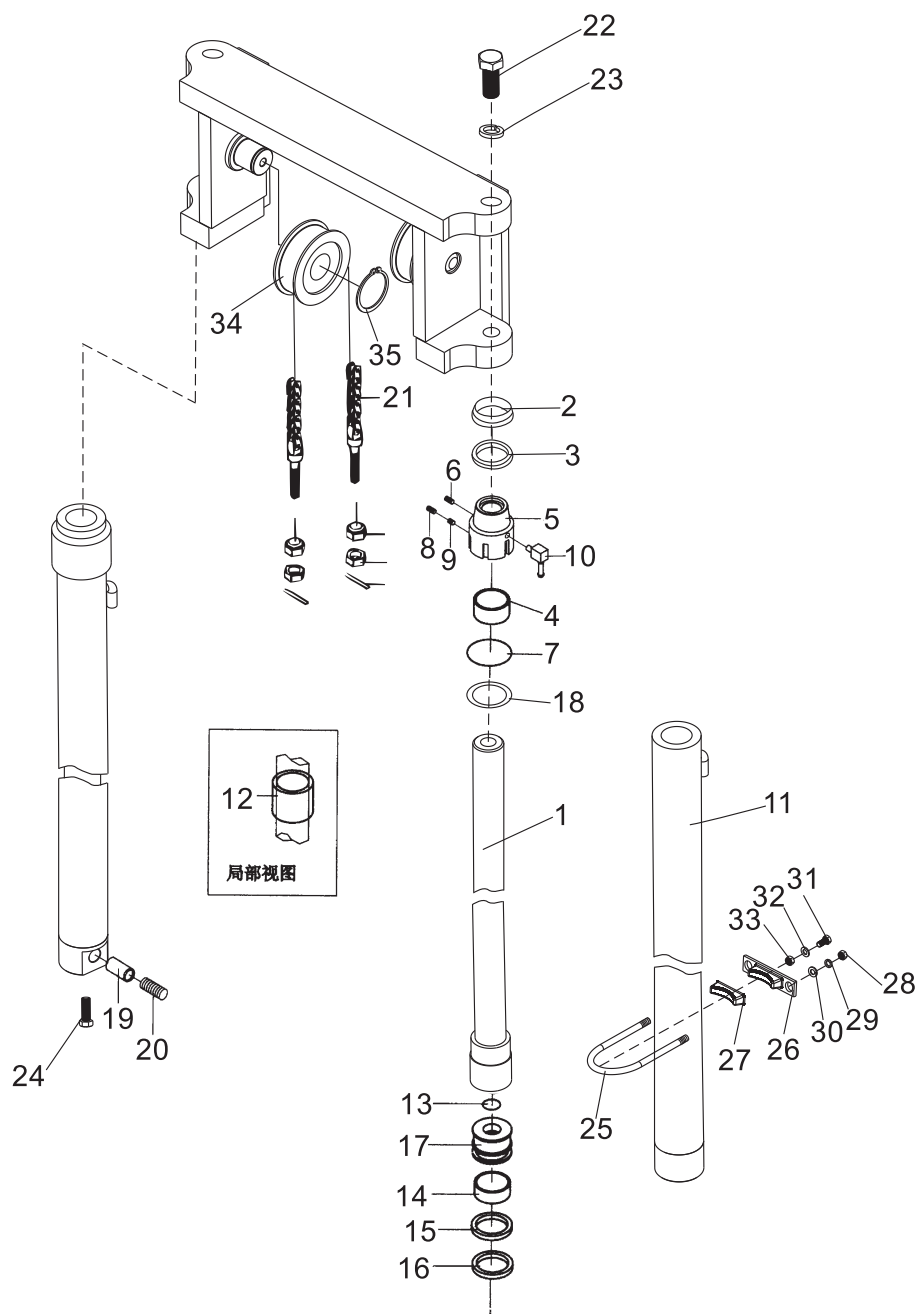

后起升油缸(三节全自由)
Rear Lift Cylinder (Full Free 3-Stage Mast KZM)

序号 Item	零件号 Part No	零部件名称 Description	数量 Q'ty	备注 Remark
25	M50A3-80004	U型螺栓 U-bolt	2	
26	M50A3-80003	油缸支撑块 Support	2	
27	M50A3-80002	调整块 Rubber	2	
28	GB/T6171	螺母M12×1.25 Nut	4	
29	GB/T93	弹垫12 Washer,lock	4	
30	GB/T97.1	平垫12 Washer	4	
31	GB/T5786	螺栓M16×1.5×70 Bolt	2	
32	GB/T97.1	平垫16 Washer	2	
33	GB/T6171	螺母M16×1.5 Nut	2	
34	M50A3-80100	链轮总成 Sheave	2	
35	GB/T894.1	挡圈55 Snap ring	2	

倾斜油缸 Tilt cylinder

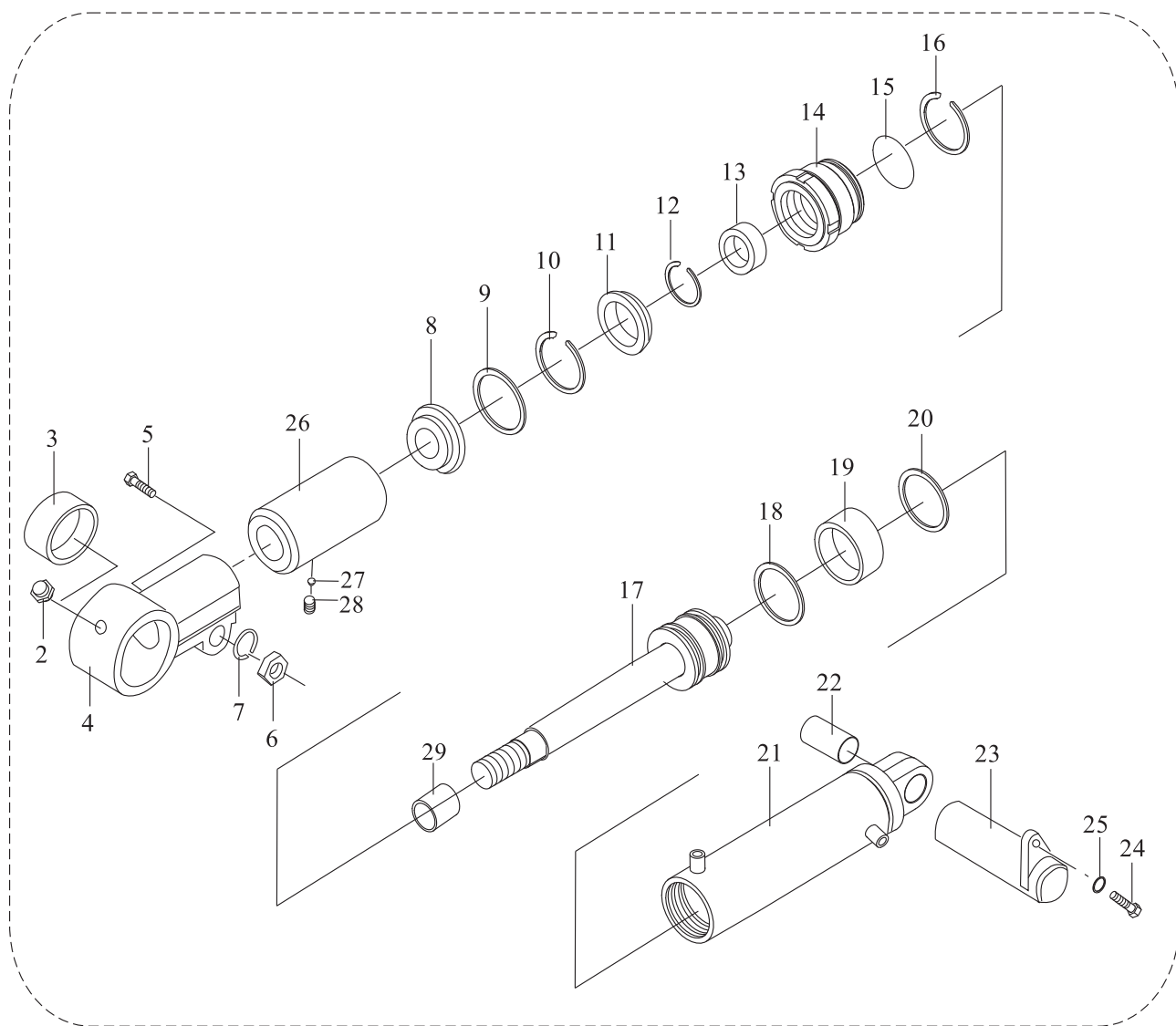

1

倾斜油缸
Tilt cylinder

序号 Item	零件号 Part No	零部件名称 Description	数量 Q'ty	备注 Remark
1	A50A3-10200	倾斜油缸总成 Tilt cylinder assy	2	
2	A50A3-10201	直通式滑油脂嘴Z1/8" Nipple grease	2	
3	A50A3-10202	钢背轴承5060 Bushing	2	
4	A50A3-10203	耳环 Ear ring	2	
5	GB/T5782	螺栓M16×70 Bolt	2	
6	GB/T6710	螺母M16 Nut	2	
7	GB/T93	弹簧垫圈16 Washer,lock	2	
8	A50A3-10204	防尘圈72 Seal,dust	2	
9	GB/T893.1	挡圈72 Ring,snap	2	
10	A50A3-10205	挡圈 Ring,snap	2	
11	A50A3-10206	U型密封圈50 U-ring	2	
12	A50A3-10207	挡圈 Ring,snap	2	
13	A50A3-10208	钢背轴承5030 Bushing	2	
14	A50A3-10209	导向套 Guide,sleeve	2	
15	GB/T1235	O型密封圈 O-ring	2	
16	A50A3-10210	挡圈 Ring,snap	2	
17	A50A3-10211	活塞体 piston body	2	
18	A50A3-10212	Yx密封圈 ring	4	
19	A50A3-10213	支承环 Wearing	2	
20	A50A3-10214	挡圈 Ring,snap	2	
21	A50A3-10215	缸体 Tube,cylinder	2	
22	A50A3-10216	钢背轴承5058 Bushing	2	
23	M50A3-00100	倾斜油缸销轴总成 Pin axle ass'y	2	

倾斜油缸 Tilt cylinder

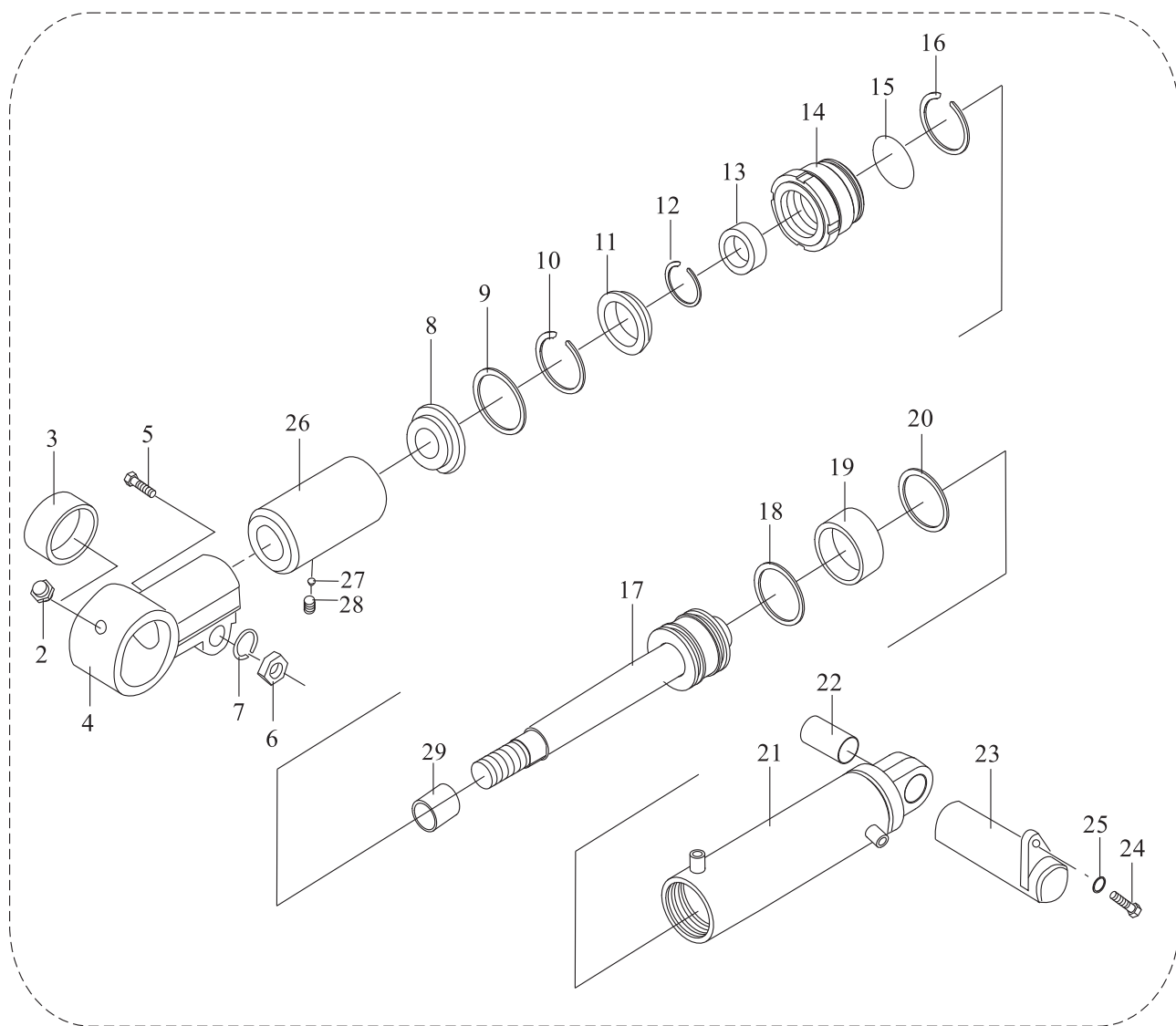

1

倾斜油缸
Tilt cylinder

序号 Item	零件号 Part No	零部件名称 Description	数量 Q'ty	备注 Remark
24	GB/T5786	螺栓M10×1.5×20 Bolt	2	
25	GB/T93	弹垫10 Washer,lock	2	
26	A50A3-10217	调整轴套 Spacer	2	
27	A50A3-10218	塞子 Plug	2	
28	GB/T73	紧定螺钉M10×12 Screw	2	
29	A50A3-10219	调整套 Bushing	2	

九、电气系统

ELECTRIC SYSTEM

液力车仪表总成 Instrument assembly(Hydraulic transmission)

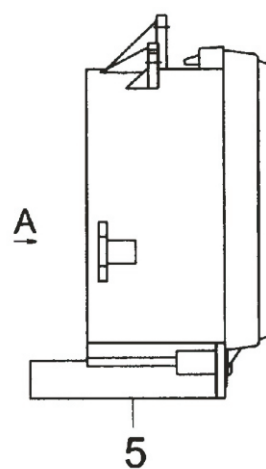
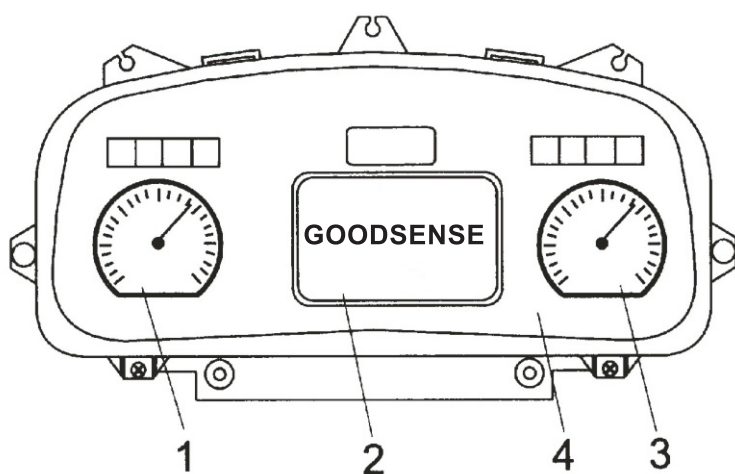

A向

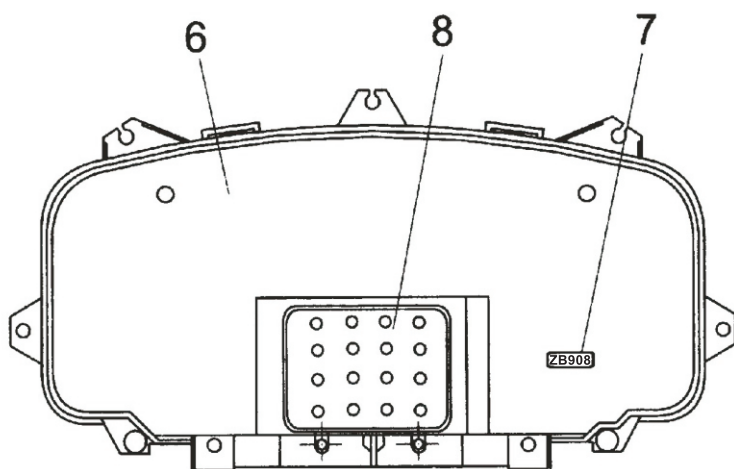

序号	名称
1	水温表盘 Temperature
2	线路板与表芯总成 Circuit board & meter core
3	燃油表盘 Fuel meter
4	面罩 Cover
5	外壳 Shunk
6	后盖板 Rrar cover
7	型号标识 Type sign
8	16线插座 16-wire socket

电气系统 Electric system

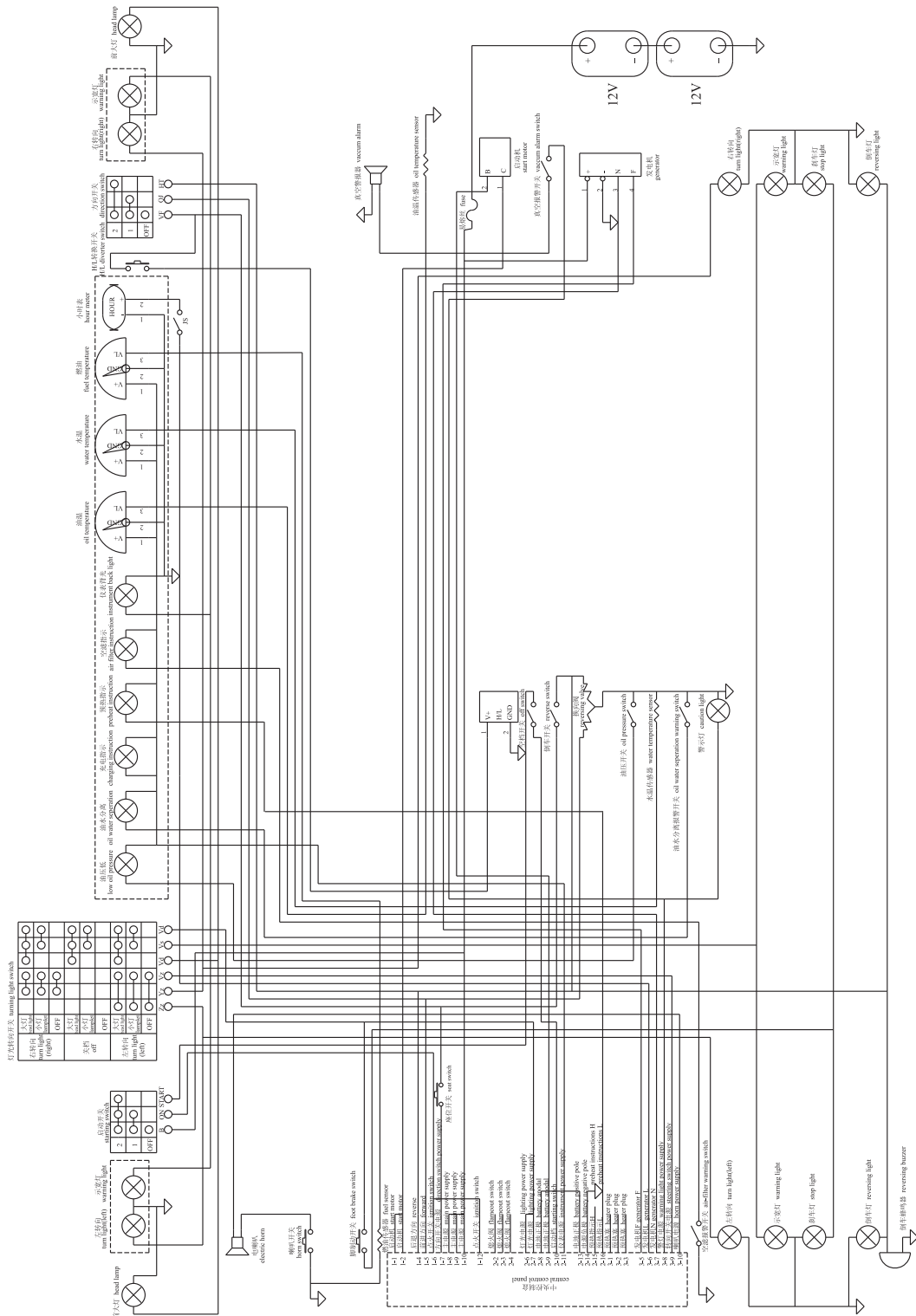

电气线路图(FD/Y50,60,70,80-CY1/S3/G3/G4)
Electrical circuit diagram(FD/Y50,60,70,80-CY1/S3/G3/G4)

电气系统

Electric system

序号 Item	零件号 Part No	零部件名称 Description	数量 Q'ty	备注 Remark
1	DT04G-24WD2	前大灯 Head lamp ass'y	2	
2	DT04G-24ZQX	前小灯 Side lamp ass'y	2	
3	DT02G-Jk804-5D	组合开关 Integral switch	1	
4	DT01G-ZB908	组合仪表 Combination	1	FD/Y50,60,70,80-CY1 /W3/S3/G3/G4/YC2
-	DT01G-ZB908W	组合仪表 Combination	1	FD50,60,70,80-KMS2
5	A30C2-00500	右护顶架线束 Right head guard harness	1	
6	DZ03G-RC3/4	油温传感器 Oil temp sending unit	1	FD50,60,70,80-CY1
7	A30B2-00900	易熔线 Fused link wire	1	/W3/S3/YC2/KMS2 FY50,60,70,80-G3/G4
-	A50K2-80200	易熔线 Fused link wire	1	FD50,60,70,80-KMS2
8	A30C2-20002	电瓶 Battery	2	FD/Y50,60,70,80-CY1 /W3/S3/G3/G4/YC2
-	A90F2-20100	电瓶 Battery	2	FD50,60,70,80-KMS2
9	A30G2-00700	电瓶引线(+) Cable	1	FD/Y50,60,70,80-CY1 /W3/G3/G4/YC2
-	A50B2-00700	电瓶引线(+) Cable	1	FD50,60,70,80-S3/KMS2
10	A50B2-01100	电瓶连接线 Battery cables	1	FD50,60,70,80-CY1/W3 /S3/YC2/KMS2
11	A30C2-00800	电瓶引线(-) Cable	1	FD/Y50,60,70,80-CY1 /W3/S3/G3/G4/YC2
-	A50B2-00800	电瓶引线(-) Cable	1	FD50,60,70,80-KMS2
12	DZ05G-YG411	油压报警开关oil pressure warning switch	1	FD50,60,70,80-CY1
-	DZ05G-YG408	油压报警开关oil pressure warning switch	1	FD50,60,70,80-S3
-	A90F2-50200	油压报警开关oil pressure warning switch	1	FD50,60,70,80-KMS2
13	DZ03G-Z3/8	水温传感器 Water temp sending unit	1	FD50,60,70,80-CY1/YC2
-	DZ03G-WG430	水温传感器 Water temp sending unit	1	FD/Y50,60,70,80-W3 /S3/G4
-	DZ03G-R1/2SY	水温传感器 Water temp sending unit	1	FY50,60,70,80-G3
-	A90F2-50100	水温传感器 Water temp sending unit	1	FD50,60,70,80-KMS2
14	DT04G-LTD152	警示灯 Caution light	1	
15	180型	捆扎带 Binding	20	

电气系统 Electric system

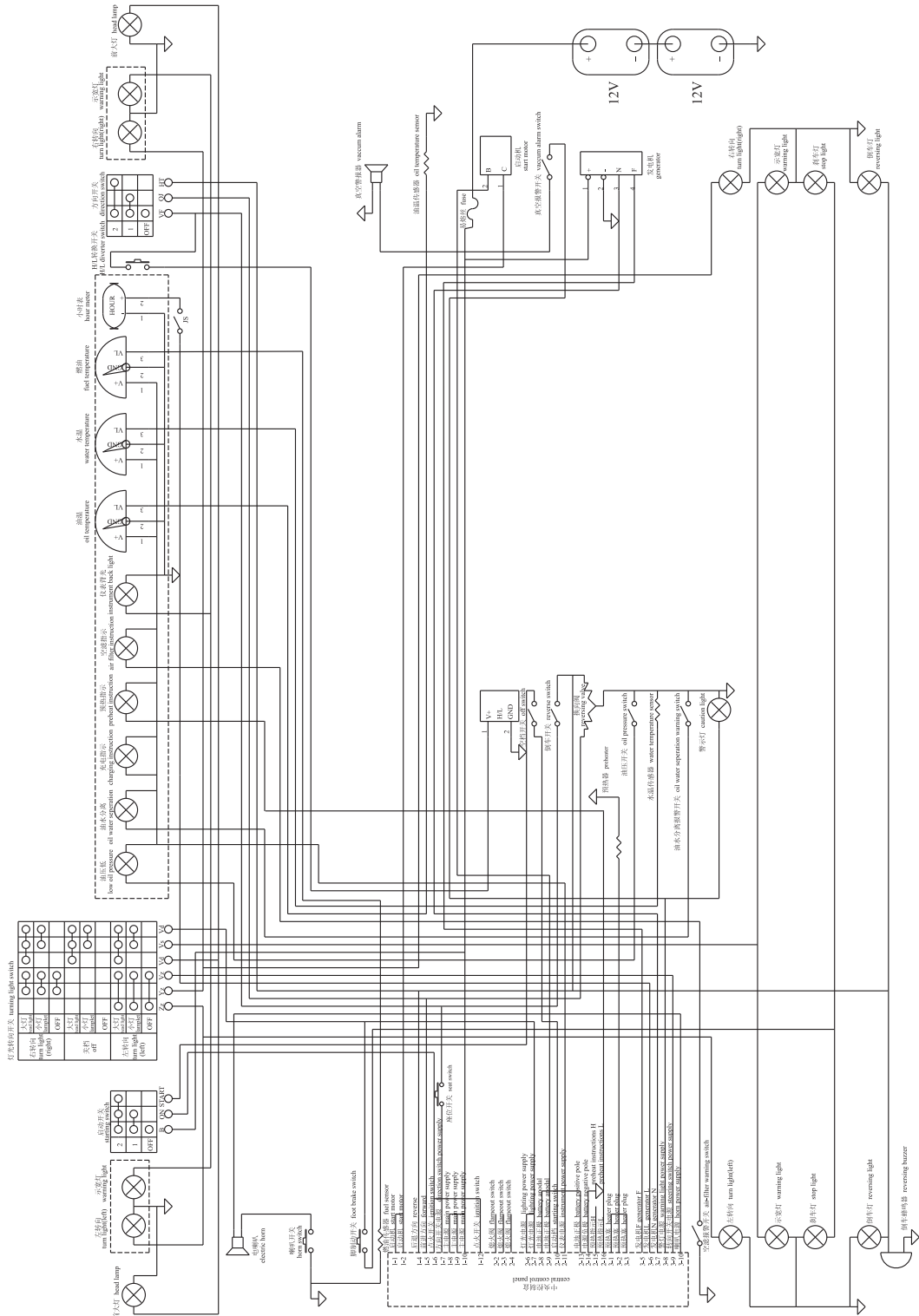

电气线路图(FD50,60,70,80-W3/YC2/KMS2)
Electrical circuit diagram(FD50,60,70,80-W3/YC2/KMS2)

电气系统
Electric system

序号 Item	零件号 Part No	零部件名称 Description	数量 Q'ty	备注 Remark
16	DT09G-DJB24B	倒车蜂鸣器 Back buzzer	1	
17	DT04G-XH8-16.3	后排灯 Rear lights	1	FD50,60,70,80-CY1 /W3/S3/KMS2
-	DT04G-XH8-16.3-12	后排灯 Rear lights	1	FD/Y50,60,70-G3/G4 /YC2
18	DT03G-YG312	燃油传感器 Fuel sensor	1	FD50,60,70,80-CY1 /W3/S3/YC2/KMS2
19	A50B2-01000	叉车中央电器盒 Panel	1	FD50,60,70,80-CY1 /W3/S3/YC2/KMS2
-	A30C2-10100	叉车中央电器盒 Panel	1	FY50,60,70,80-G3/G4
20	DT05G-JK205A	脚制动开关 Brake switch	1	
21	A50C2-80100	整车线束 Vehicle harness	1	FD50,60,70,80-CY1
-	A50D2-80100	整车线束 Vehicle harness	1	FD50,60,70,80-W3
-	A50E2-80100	整车线束 Vehicle harness	1	FD50,60,70,80-S3
-	A50F2-80100	整车线束 Vehicle harness	1	FY50,60,70,80-G4
-	A50I2-80100	整车线束 Vehicle harness	1	FY50,60,70,80-G3
-	A50G2-80100	整车线束 Vehicle harness	1	FD50,60,70,80-YC2
-	A50K2-80100	整车线束 Vehicle harness	1	FD50,60,70,80-KMS2
22	DT09G-DL224ED	电喇叭 Horn	1	
23	A30C2-00400	左护顶架线束 Left head guard harness	1	
24	JD281A-120A	启动继电器 Starter relay	1	FD50,60,70,80-CY1/S3
-	JD281A-120A	启动继电器 Starter relay	2	FD50,60,70,80-KMS2
25	TD06G-JD1914	中间继电器 Auxiliary relay	1	FY50,60,70,80-G3/G4

十、标牌

SCUTCHEON

标牌
Decal

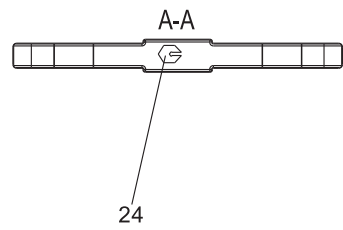
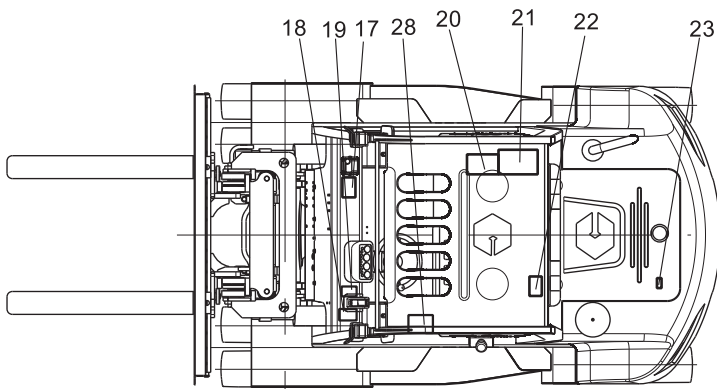
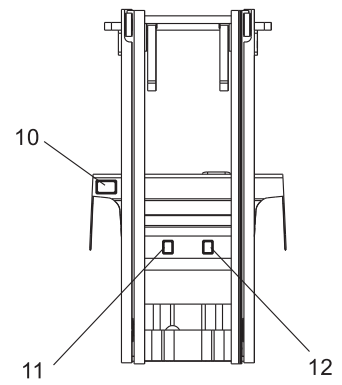
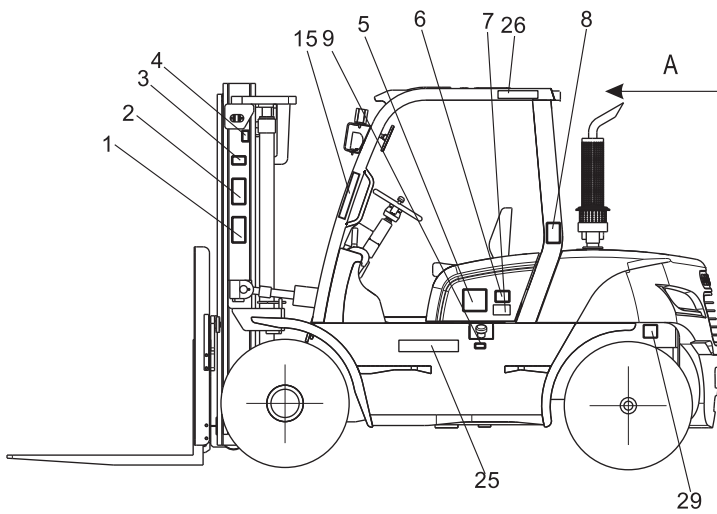
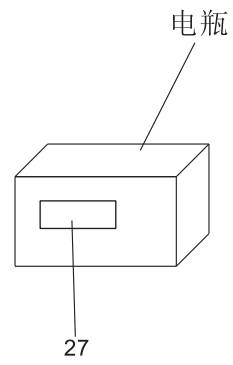
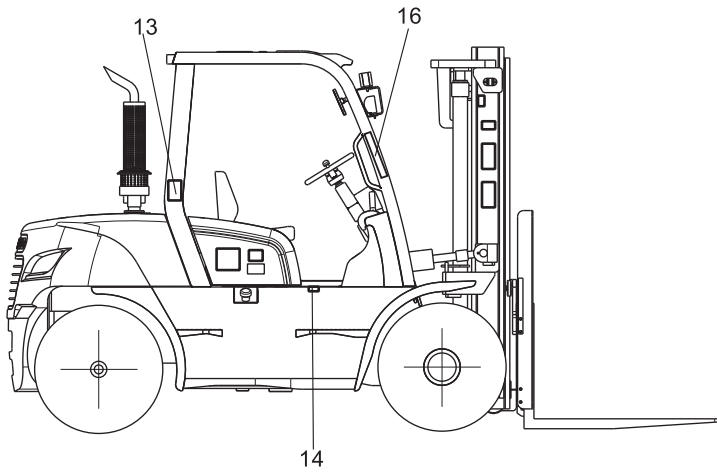

标牌 Decal

序号 Item	零件号 Part No	零部件名称 Description	数量 Q'ty	备注 Remark
1	GCI0170	“吉鑫祥”字样 Decal	2	国内用homeland
-	GCI0039	“GOODSENSE”（中） Decal	2	国外用go abroad
2	GCI0001	安全标志标牌 Decal, safety	2	国内用homeland
-	GCIY053	安全标志标牌 Decal, safety	2	国外用go abroad
3	GCI0022	CE标识 Decal	2	国外用go abroad
4	GCI0014	起吊标牌 Decal,sling	2	国内用homeland
-	GCIY066	起吊标牌 Decal,sling	2	国外用go abroad
5	GCI0006	叉车型号标牌 Decal,model	2	
6	GCI0034	“50”字样 Decal	2	5t
-	GCI0035	“60”字样 Decal	2	6t
-	GCI0036	“70”字样 Decal	2	7t
-	GCI0037	“80”字样 Decal	2	8t
7	GCI0041	“GOODSENSE”（小） Decal	1	
8	GCI0005	启动前检查要领 Decal,caution	1	国内用homeland
-	GCIY057	启动前检查要领 Decal,caution	1	国外用go abroad
9	GCI0008	加柴油标牌 Decal,fuel	1	国内柴油用homeland
-	GCI0092	加LPG标牌 Decal,fuel	1	国内LPG用homeland
-	GCIY060	加柴油标牌 Decal,fuel	1	国外柴油用go abroad
-	GCIY096	加LPG标牌 Decal,fuel	1	国外LPG用go abroad
10	GCI0418	内燃平衡重式叉车铭牌 Name plate	1	国内用homeland
-	GCIY419	内燃平衡重式叉车铭牌 Name plate	1	国外用go abroad
11	GCI0016	禁止进入门架后空间Decal, padlod mast space	1	国内用homeland
-	GCIY068	禁止进入门架后空间Decal, padlod mast space	1	国外用go abroad
12	GCI0017	注意伤手 Decal,notice thumb hand	1	国内用homeland
-	GCIY069	注意伤手 Decal,notice thumb hand	1	国外用go abroad
13	GCI0013	轮胎安全标牌 Decal,tyre safety	1	国内用homeland
-	GCIY065	轮胎安全标牌 Decal,tyre safety	1	国外用go abroad

标牌
Decal

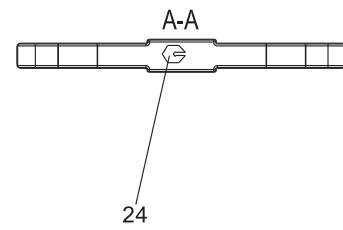
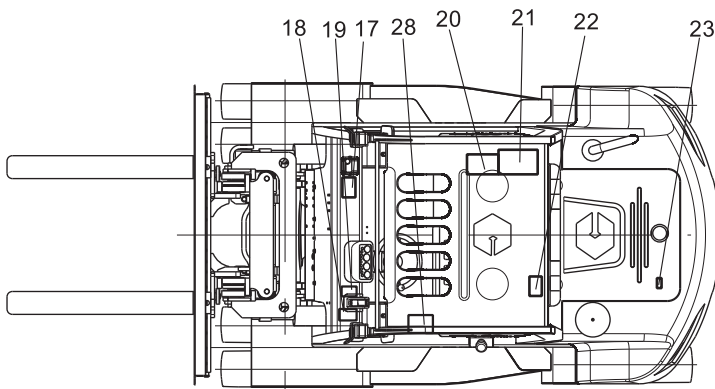
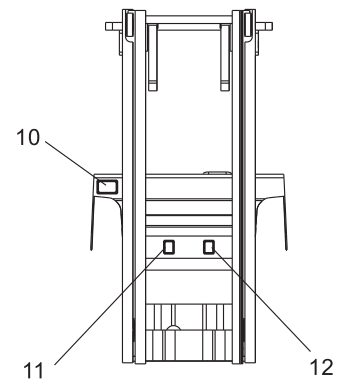
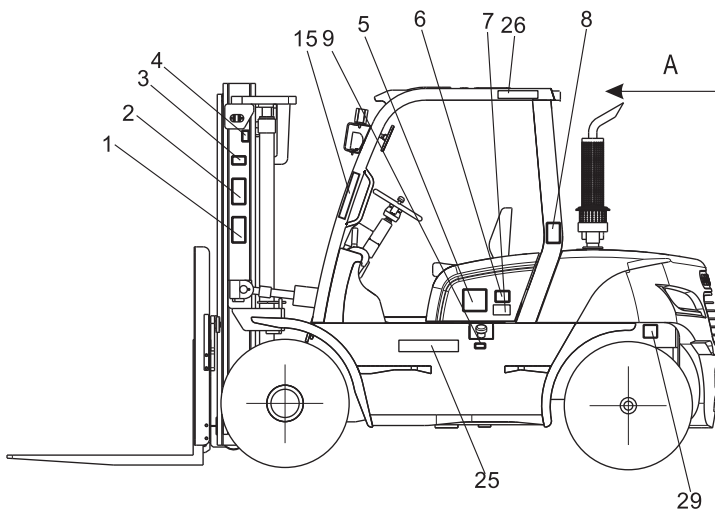
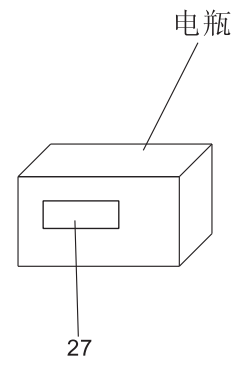
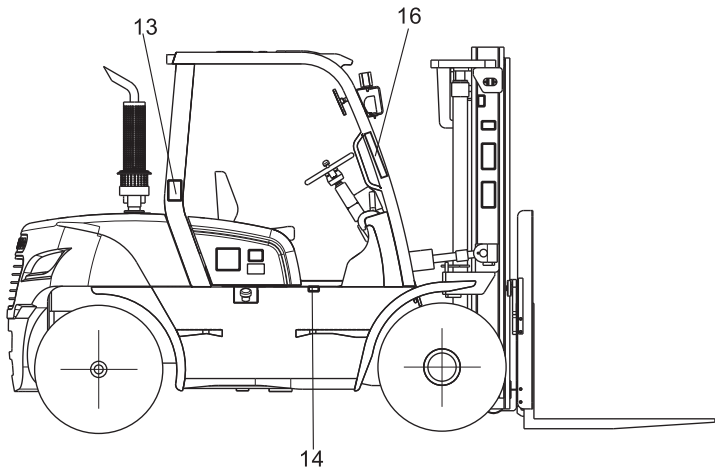

标牌 Decal

序号 Item	零件号 Part No	零部件名称 Description	数量 Q'ty	备注 Remark
14	GCI0010	加液压油标牌Decal,adding hydraulic oil	1	国内用homeland
-	GCIY062	加液压油标牌Decal,adding hydraulic oil	1	国外用go abroad
15	GCIY273	阅读说明书警告标志 Read instructions warning	1	
16	GCIY272	系安全带警告标识Fasten seat belts warning logo	1	
17	GCI0051	负荷曲线标牌5-7t Decal,Iubrication chart	1	国内用homeland
-	GCIY083	负荷曲线标牌5-7t Decal,Iubrication chart	1	国外用go abroad
18	GCI0407	下车拉紧手刹Decal,Parking brake adjustment	1	国内用homeland
-	GCIY275	下车拉紧手刹Decal,Parking brake adjustment	1	国外用go abroad
19	GCI0412	手刹标识 Decal	1	国内用homeland
-	GCIY411	手刹标识 Decal	1	国外用go abroad
20	GCI0003	润滑系统图标牌 Decal,Iubrication chart	1	国内用homeland
-	GCIY055	润滑系统图标牌 Decal,Iubrication chart	1	国外用go abroad
21	GCI0004	使用须知标牌 Decal	1	国内用homeland
-	GCIY056	使用须知标牌 Decal	1	国外用go abroad
22	GCI0012	风扇安全标牌 Decal,fan safety	1	国内用homeland
-	GCIY064	风扇安全标牌 Decal,fan safety	1	国外用go abroad
23	GCI0009	加防冻液标牌 Decal,antifreeze liquid	1	国内用homeland
-	GCIY061	加防冻液标牌 Decal,antifreeze liquid	1	国外用go abroad
24	GCI0098	Logo(中) 标牌 Decal	1	
25	GCI0103	“吉鑫祥叉车” 字样 Decal	1	国内用homeland
26	GCI0122	警告标识 Warning logo	1	国内用homeland
-	GCIY124	警告标识 Warning logo	1	国外用go abroad
27	GCI0121	电气警告标识 Electrical warning logo	1	国内用homeland
-	GCIY125	电气警告标识 Electrical warning logo	1	国外用go abroad
28	GCI0409	禁止载人标牌 Ban manned sign	1	国内用homeland
-	GCIY410	禁止载人标牌 Ban manned sign	1	国外用go abroad
29	GCIY408	配重起吊标识 Weight lifting logo	2	

浙江吉鑫祥叉车制造有限公司

ZHEJIANG GOODSENSE FORKLIFT CO.,LTD

地址:台州经济开发区滨海工业区海昌路1188号

Add:Haichang Road 1188#, Binhai Industrial Zone
Taizhou, Zhejiang, China

电话(Tel):0576-82698896 0086-576-82698897

传真(Fax):0576-82698899 0086-576-82707339

邮箱(E-mail):sales@goodsenseforklift.com

网址Http://www.goodsenseforklift.com

服务热线(Free Service Hot line):400-8802020

NO:A022