

# 说 明

1. 本“零件目录”汇集了 CPD30-35 叉车的零部件。
2. 查询方法:
  - 2.1 用户可根据目录中各总成图查找所需零部件的序号, 根据序号可查得相应的图号或标准件号。
  - 2.2 目录中图样的右上角表示此总成所适应的车型, 通用的零部件不加说明。
3. 订购零件时, 须写清楚所用叉车的型号, 叉车出厂编号, 所需零部件号及订购数量。
4. 维修更换零部件时为确保叉车质量, 希望使用本厂的零部件。
5. 为提高叉车的质量, 本厂将对叉车中某些零部件作些改进, 对于改进部分在此手册中不能同时进行一一修改, 请用户谅解。欲了解详细情况可与本厂销售公司或配件公司联系。
6. 叉车型号说明:

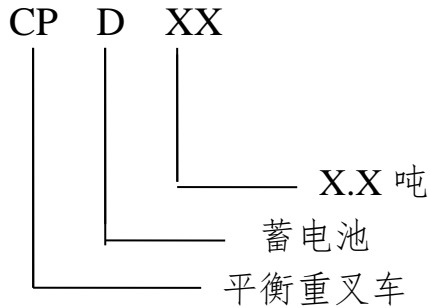

## 7. 缩写说明

ASS`Y 总成  
SW 关  
HP 高压

INC 包含  
L.H 左  
ATT. 属具

DIFF 差速器  
CYL 油缸  
LP 低压

R.H 右  
OP. 选用  
AR. 按需

# INFORMATION

1. This MANUAL collects all of the parts in Series CPD fork lift trucks having capacities from 3tonne through 3.5 tonne.
2. Methods of looking up a part or a component in the MANUAL:  
First looking up the series number of a part or a component in the drawing of the assembly ,in which the part or the component is,in the MANUAL and then the code of the drawing and standard of the part or the components in terms of the series number.  
The notes,indicating the assembly is applicable for a truck ,are the right top of the assembly drawing.
3. When you want to order a part ,please tell us the model and the series NO. of the truck ,in which it is,it's code of drawing and quantity.
4. For good work of your truck it is recommended to use the parts and compenent made by us if you need them in the serve and maintenance of it.
5. We reserve the right of change of the truck in construction for improving our products without notice .For the details of the change,please consult with the Sales Department.
6. Designations in the MANUAL:

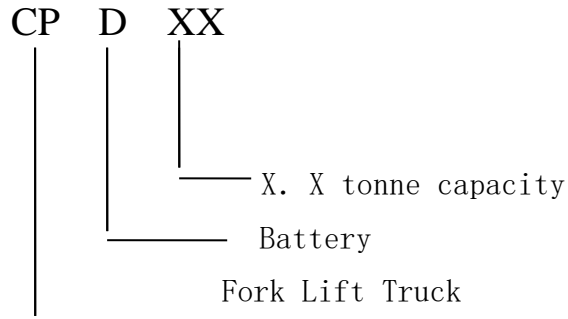

## 7. Abbreviations in the MANUAL:

ASS`Y	Assembly	INC	Include	DIFF	Differential	R.H	Right hand
SW	Switch	L.H	Left hand	CYL	Oil pressure cylinder	OP.	Option
HP	High pressure	ATT.	Attachment	LP	Low pressure	AR.	According to requirement

## TABLE of CONTENTS 目录

说 明 .....	1
INFORMATION .....	2
I FRAME SYSTEM 车身系统 .....	5
II DRIVE SYSTEM 驱动系统 .....	8
1. DRIVER WHEEL (SINGLE TIRE) 驱动轮 (单胎) .....	8
2. DRIVER WHEEL (DOUBLE TIRE) 驱动轮 (双胎) .....	9
3. DRIVE AXLE 驱动桥 .....	10
4. DRIVE AXLE(DOUBLE TIRE) 驱动桥 (双胎) .....	12
5. BRAKE ASSEMBLY 制动器总成 .....	14
2. STEERING CYLINDER 转向油缸 .....	18
3. STEERING WHEEL 转向轮 .....	19
IV TRANSMISSION SYSTEM 传动系统 .....	20
1. REDUCER ASSEMBLY 变速箱总成 .....	20
2. TRANSMISSION SYSTEM 传动系统 .....	23
V HOOD & FLOORBOARD 机罩与底板类 .....	24
VI BRAKE SYSTEM 制动系统 .....	26
1. SERVICE BRAKE SYSTEM 行车制动系统 .....	26
2. PARKING BRAKE SYSTEM 停车制动系统 .....	27
VII OVERHEAD GUARD 护顶架 .....	28
VIII STEERING SYSTEM 转向系统 .....	30
IX ELECTRIC SYSTEM 电气系统 .....	31
X HYDRAULIC SYSTEM 液压系统 .....	66
1. HYDRAULIC SYSTEM 液压系统 .....	66
2. MULTI-WAY VALVE & STEERING UNIT ASS`Y 多路阀转向器预装图 .....	67
3. GEER PUMP ASS`Y 多路阀转向器预装图 .....	68
4. VALVE CONTROL LINKAGE 阀操纵总成 .....	69
5. HYDRAULIC TANK 工作油箱 .....	70

6.POWER CYLINDER 转向油缸.....	71
X I MAST 门架.....	72
1. HYDRAULIC SYSTEM MAST 门架管路系统（基本型）.....	72
2. HYDRAULIC SYSTEM MAST 门架管路系统（二级全自由）.....	73
3. HYDRAULIC SYSTEM MAST 门架管路系统（三级全自由）.....	75
4. MAST 门架（基本型）.....	76
5. MAST 门架（二级全自由）.....	77
6. MAST 门架（三级全自由）.....	78
7. FORK&LIFT BRACKET 货叉及货叉架（基本型）.....	79
8. FORK&LIFT BRACKET 货叉及货叉架（二级全自由）.....	80
9. FORK&LIFT BRACKET 货叉及货叉架（三级全自由）.....	81
10. LIFT CYLINDER 起升缸（基本型）.....	82
11. REAR LIFT CYLINDER 后起升缸（二级全自由）.....	83
12. FRONT LIFT CYLINDER 前起升缸（二级全自由）.....	85
13. LIFT CYLINDER 后起升缸（三级全自由）.....	86
14.FRONT LIFT CYLINDER 前起升缸（三级全自由）.....	87
15.LIFT CYLINDER 倾斜油缸.....	88
X II SIGNAGE 标识标贴.....	90









## 2. DRIVER WHEEL (DOUBLE TIRE) 驱动轮 (双胎)

图 03 驱动轮 (双胎)					DRIVER WHEEL (DOUBLE TIRE)
序号 Item No	图 号 Part No	零部件名称 Description	件数 Q' ty	备 注 Remark	CPD30、CPD35
01	028×9-15-14PR- GB/T10823	Tire 充气轮胎	4	CPD30 标配	
-	028×9-15- GB/T16623	Tire 实心轮胎	4	CPD35 标配	
-	028×9-15- GB/T16623	Tire 环保实心轮胎	4	CPD30、35 选配	
02	CDQ3A-06001	Rim 7.00-12 轮辋总成 (双胎)	2		
03	CDQ3A-03031	Bolt 轮辋螺栓	12		
04	CDQ3A-03041	Nut 轮辋螺母	12		
05	CDQ3A-03051	Pipe 充气接管	2		

### 3. DRIVE AXLE 驱动桥

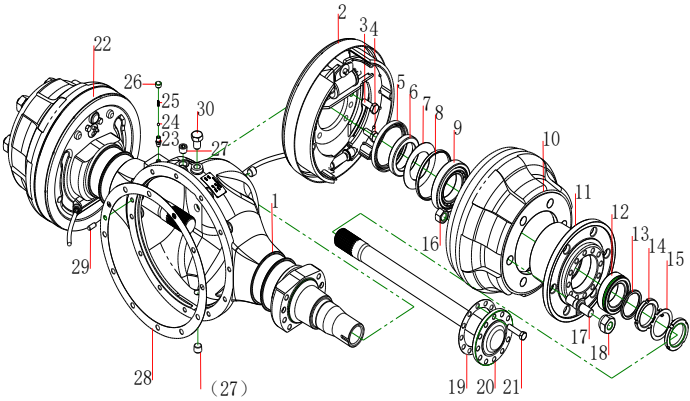
图 04 驱动桥					DRIVE AXLE
序号 Item No	图号 Part No	零部件名称 Description	件数 Q' ty	备注 Remark	CPD30、CPD35  
01	C1Q11-02011	Axle house 桥体	1		
02	C1Q11-09001	Brake ass' y Right 右制动器	1		
03	OM14×1.5×30	Bolt 螺栓 M14×1.5×30	4	GB/T5785-2000	
-	-GB/T5785				
04	OM14×1.5×30	Bolt 螺栓 M14×1.5×30	12	GB/T5786-2000	
-	-GB/T5786				
05	O125×100×12	Seal 旋转轴唇密封圈	2	GB/T13871.1	
-	-GB/T13871.1			-2007	
06	C1Q11-02071	Oil seal 油封	2		
07	C1Q11-02041	Oil seal 挡油圈	2		
08	C1Q11-02051	Seal 挡圈	2		
09	O30214E-GB/T307	Bearing 圆锥滚子轴承 30214E	2	GB/T307-2005	
10	C1Q11-02031	Brake drum 制动毂	2		
11	C1Q11-02061	Wheel hub 轮毂	2		
12	O33012-GB/T307	Bearing 圆锥滚子轴承 33012A	2	GB/T307-2005	
13	C1Q11-02081	Washer 垫片	2		
14	OM60-GB/T810	Nut 圆螺母 M60	2	GB/T810-1988	
15	OΦ60-GB/T858	Washer 圆螺母制动垫圈	2	GB/T858-1988	
16	OM20-GB/T6171	Nut 六角螺母 M20	12	GB/T6171-2000	
17	C1Q11-02101	Bolt 轮毂螺栓	12		
18	C1Q11-02111	Nut 轮毂螺母	12		
19	CDQ3A-01031	Gasket 半轴垫	2		
20	C1Q11-02091	Half shaft Right 半轴右	1		
21	OM12×1.25×50	Bolt 螺栓 M12×1.25×50	24	GB/T5785-2000	
-	-GB/T5785				
22	OM18×1.5×25	Bolt 螺栓 M18×1.5×25	1	GB/T5786-2000	



#### 4. DRIVE AXLE (DOUBLE TIRE) 驱动桥 (双胎)

图 05 驱动桥 (双胎)					DRIVE AXLE (DOUBLE TIRE)
序号 Item No	图号 Part No	零部件名称 Description	件数 Q' ty	备注 Remark	CPD30、CPD35  
01	C1Q11-02011	Axle house 桥体	1		
02	C1Q11-09001	Brake ass' y Right 右制动器	1		
03	OM14×1.5×30	Bolt 螺栓 M14×1.5×30	4	GB/T5785-2000	
-	-GB/T5785				
04	OM14×1.5×30	Bolt 螺栓 M14×1.5×30	12	GB/T5786-2000	
-	-GB/T5786				
05	O125×100×12	Seal 旋转轴唇密封圈	2	GB/T13871.1	
-	-GB/T13871.1			-2007	
06	C1Q11-02071	Oil seal 油封	2		
07	C1Q11-02041	Oil seal 挡油圈	2		
08	C1Q11-02051	Seal 挡圈	2		
09	O30214E-GB/T307	Bearing 圆锥滚子轴承 30214E	2	GB/T307-2005	
10	C1Q11-02031	Brake drum 制动鼓	2		
11	C1Q11-02061	Wheel hub 轮毂	2		
12	O33012-GB/T307	Bearing 圆锥滚子轴承 33012A	2	GB/T307-2005	
13	C1Q11-02081	Washer 垫片	2		
14	OM60-GB/T810	Nut 螺母 M60	2	GB/T810-1988	
15	OΦ60-GB/T858	Washer 圆螺母制动垫圈	2	GB/T858-1988	
16	OM20-GB/T6171	Nut 螺母 M20	12	GB/T6171-2000	
17	C1Q11-02101	Bolt 轮毂螺栓	12		
18	C1Q11-02201	Nut 螺母	12		
19	C1Q11-02111	Nut 轮毂螺母	12		
20	C1Q11-01031	Gasket 纸垫	2		
21	C1Q11-02091	Half shaft Right 半轴右	1		
22	OM12×1.25×50	Bolt 螺栓 M12×1.25×50	24	GB/T5785-2000	
-	-GB/T5785				

图 05		驱动桥 (双胎)			DRIVE AXLE (DOUBLE TIRE)			
序号	图 号	零部件名称	件数	备 注	CPD30、CPD35			
Item No	Part No	Description	Q' ty	Remark				
23	C1Q11-08001	Brake ass' y Left 左制动器	1					
24	C1Q11-02151	Vented plug 通气塞	1					
25	0Φ6-GB/T308	Ball 钢球	1					
26	C1Q11-02161	Spring 压缩弹簧	1					
27	C1Q11-02171	Nut 螺母	1					
28	C1Q11-02181	Plug 螺塞	3					
29	C1Q11-01021	Gasket 主传动垫	1					
30	08M6×24	Pin 圆柱销	1	GB/T119.2				
-	-GB/T119.2			-2000				
31	C1Q11-02191	Half shaft Left 半轴左	1					

## 5. BRAKE ASSEMBLY 制动器总成

图 06		制动器总成			BRAKE ASSEMBLY
序号	图 号	零部件名称	件数	备 注	CPD30、CPD35
Item No	Part No	Description	Q' ty	Remark	
A	C1Q11-08001	Wheel brake ass'y (LH)	1		
-		制动器总成 (左)			
-	C1Q11-09001	Wheel brake ass'y (RH)	1		
-		制动器总成 (右)			
01	OM8×1.25×25	Bolt 螺栓 M8×1.25×25	4	GB/T5785-2000	
-	-GB/T5785				
02	08-GB93	Washer 垫圈 8	4	GB93-87	
03	C1Q11-08211	Cover, adjusting hole 胶堵	2		
04	C1Q11-08181	Pin, shoe hold 压簧拉杆	4		
05	C1Q11-08011	Back plate 制动器底板总成	2	左右对称各一	
06	C1Q11-08261	Rivet 销钉	2		
07	C1Q11-08051	Lever brake 手制动拉杆	2	左右对称各一	
08	C1Q11-08031	Brake shoe 制动蹄带摩擦片总成	2		
09	C1Q11-08131	Washer, cup 压簧座	2		
10	C1Q11-08161	Spring 压缩弹簧	4		
11	C1Q11-08141	Spring 弹簧	2		
12	C1Q11-08041	Detent 棘爪	2		
13	C1Q11-08071	Reed 扭簧	2		
14	C1Q11-08021	Adjusting cover 间隙调整套	2	左右螺旋各一	
15	C1Q11-08081	Spring Distaff 弹簧拉线装置	2		
16	C1Q11-08061	Spring 右回位弹簧 (后)	2	左右对称各一	
17	C1Q11-08091	Bush 导向块	2		
18	C1Q11-08111	Spring 右回位弹簧 (前)		左右对称各一	
19	C1Q11-08121	Board 导向板	2		
20	C1Q11-08151	Brake 制动蹄带摩擦片及挂簧销	2	左右对称各一	
21	C1Q11-08241	Body 制动分泵总成	2		

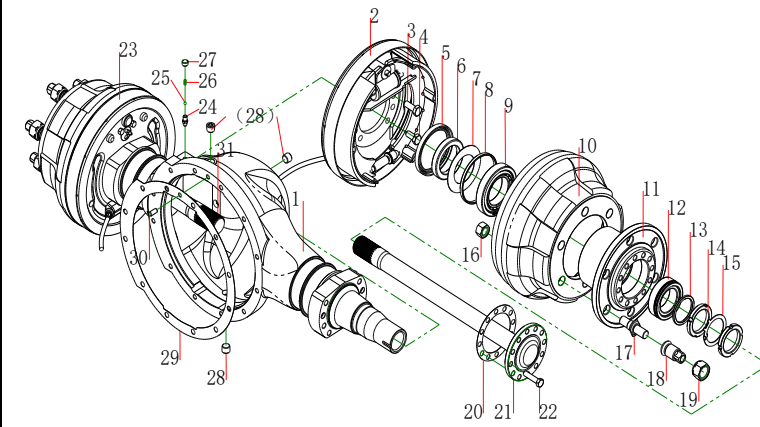

图 07		转向桥 (JAC-015)		STEERING ALLE	
序号 Item No	图号 Part No	零部件名称 Description	件数 Qty	备注 Remark	CPD30、CPD35
01	Z2035-QT000	Axle ass'y 转向桥体总成	1	3-3.5吨	
02	Z3035-LG000	Link 连杆	2		
03	Z2035-ZXYG	Power cylinder ass'y 转向油缸总成	1	3-3.5吨	
04	Z3035-LGLS	Bolt 轮毂螺栓 M14×1.5×48	1		
05	Z3035-LGLM	Nut 轮毂螺母 M14×1.5	1		
06	Z3035-ZXJ-L	Knuckle L.h. ass'y 左转向节总成	1		
07	051208-GB/T30	Bearing 推力轴承 51208	2	GB/T301-1995	
- 1					
08	0943/32-GBT29	Bearing 滚针轴承 943/32	4	GB/T290-1988	
09	Z3035-ZX000	Pin, king 转向节主销	2		
10	0B10h6×20-GB	Pin 圆柱销 B10h6×25	2	GB119.1-2000	
- 119.1					
11	Z3035-TZD00	Shim 调整垫	n		
12	0SC85×110×	Seal oil 油封 SC85×110×12	2	GB/T9877-2000	
- 12-GB9877.1					
13	Z3035-TZD01	Shim 转向节调整垫	n		
15	Z3035-CT000	Bushing 衬套	2		
16	030211-GB/T29	Bearing 轴承 30207	2	GB/T297-1994	
- 7					
17	030207-GB/T29	Bearing 轴承 30211	2	GB/T297-1994	
- 7					
18	ZAH3035-KCLM	Nut 开槽螺母 M30×2	2		
19	030-GB/T97.1	Washer 垫圈 30	2	GB/T97.1-2002	
20	06.3×56-GB/T	Pin 销 6.3×56	2		
- 91					

图 07		转向桥(JAC-015)		STEERING AXLE	
序号 Item No	图 号 Part No	零部件名称 Description	件数 Qty	备 注 Remark	CPD30、 CPD35
21	Z3035-LGG00	Cap 轮毂盖	2		
22	Z3035-LG000	Hub 轮毂	2		
23	OM12-GB/T61	Nut 六角扁螺母 M12	2	GB/T6172.1-2000	
-	72.1				
24	012-GBT97.1	Washer 垫圈 12	2	GB/T97.1-2002	
25	OM12×30-GB	Hub 内六角锥端紧定螺钉 M12×30	2		
-	/T78				
26	Z3035-FCZ00	Cap 防尘罩	2		
27	OM6-GB/T794	Fitting grease 油杯 M6	4	GB/T1152-1985	
-	0				
28	Z3841-ZXJ-L	Knuckle R. h. ass'y 右转向节总成	1		
29	OM14×40-GB	Bolt 螺栓 M14×40	4	GB/T5782-2000	
-	/T5782				
30	014-GBT97.1	Washer 垫圈 14	4	GB/T97.1-2002	
31	0FB32×40×7-	Seal oil 防尘密封圈 FB32×40×7	4	GB/T10708.3-1987	
-	GB/T10708.3				
32	031.7×4.7-	O-ring 0型圈 31.7×4.7	2	JB/T7757.2	
-	JB/T7757.2				
33	Z3035-DQ000	Bushing 挡圈	4		
35	0Z1/8-27(90°)	Fitting grease 油杯 Z1/8-27(90°)	4	JBT7904.2-2000	
-	-JB/T7904.2				
36	OM8×16-GB/	Bolt 螺栓 M8×16	4	GB/T5783-2000	
-	T5783				
37	014-GBT97.1	Washer 垫圈 14	4	GB/T97.1-2002	
38	Z3035-DB000	Baffle 挡板	2		
39	Z3035-LGX00	Pin 连杆销	4		
40	0GE16-GB/T304	Bearing 关节轴承 GE16	4	GB/T304-1987	

## 2. STEERING CYLINDER 转向油缸

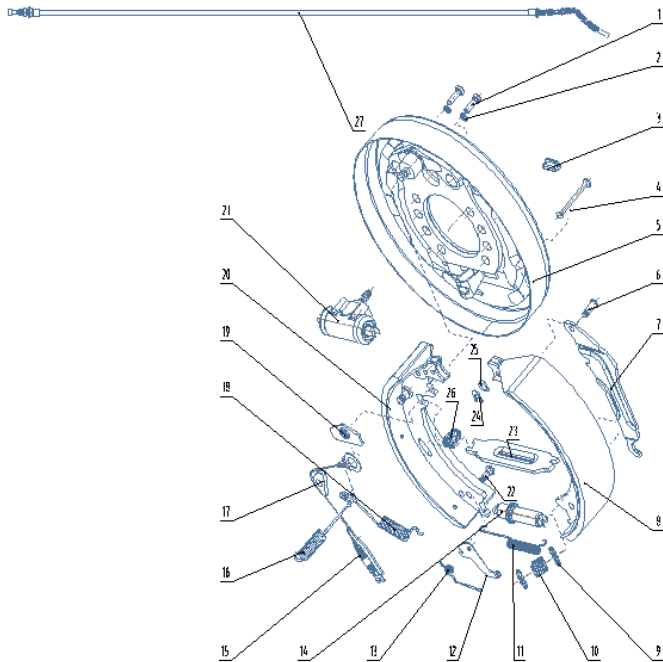
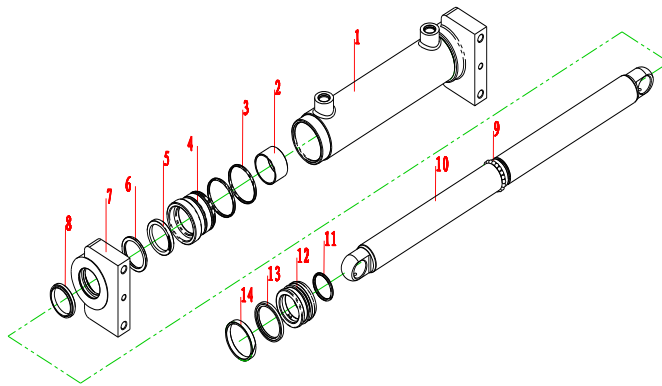
图 08 转向油缸					STEERING CYLINDER
序号 Item No	图号 Part No	零部件名称 Description	件数 Q' ty	备注 Remark	CPD30、CPD35  
01	C1W04-02211	Cylinder 缸筒	1		
02	C1W04-02221	Bearing 轴承	2		
03	C1W04-02231	O ring 0型圈	4		
04	C1W04-02241	Cylinder Cover 缸套	2		
05	C1W04-02251	Ring 活塞杆密封圈	2		
06	C1W04-02261	Ring 挡圈	2		
07	C1W04-02271	Cylinder Board 缸盖	2		
08	C1W04-02281	Shield 防尘圈	2		
09	C1W04-02291	Ball 钢球	22		
10	C1W04-02301	Piston Staff 活塞杆	1		
11	C1W04-02311	O ring 0型圈	1		
12	C1W04-02321	Piston 活塞	1		
13	C1W04-02331	Ring 密封圈	1		
14	C1W04-02341	Suppot Ring 支撑环	1		

### 3. STEERING WHEEL 转向轮

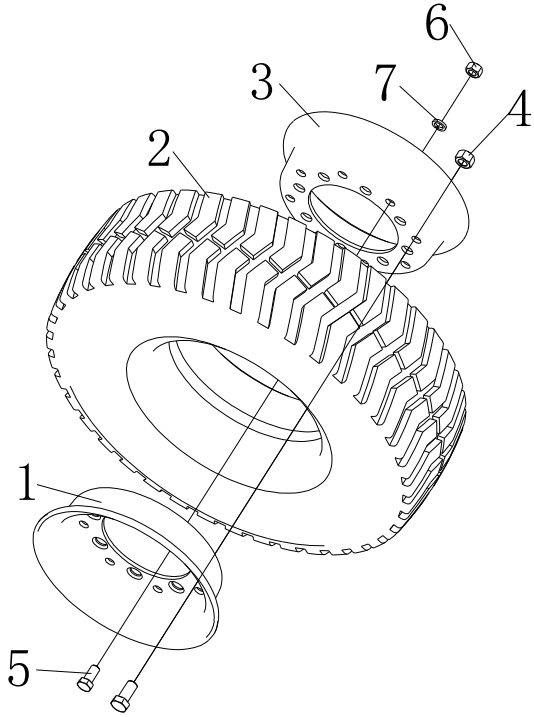
图 09		转向轮			STEERING WHEEL
序号	图 号	零部件名称	件数	备 注	
Item No	Part No	Description	Q' ty	Remark	
01	C3W2A-01021	Rim outside 外轮	2	3-3.5 吨	
02	06.50-10-10	Tire 轮胎 6.00-9-10PR	2	GB/T2982-2001	
	PR-GBT2982			3-3.5 吨	
03	C2W3A-01011	Rim inside 内轮辋		3-3.5 吨	
04	C3W2A-01031	Nut 轮毂螺母	16		
05	C2W3A-01031	Bolt 轮辋螺栓	16		
06	0M12x1.25-	Nut 螺母 M12x1.25	16	GB/T6171-2000	
-	GBT6171				
07	012-GB93	Washer 垫	16	GB93-87	

# IV TRANSMISSION SYSTEM 传动系统

## 1. REDUCER ASSEMBLY 变速箱总成

图 10		变速箱总成			TRANSMISSION ASS ' Y	
序号	图 号	零部件名称	件数	备 注	CPD30、CPD35	
Item No	Part No	Description	Q' ty	Remark		
01	C1C11-01011	gear boxhouse 箱体	1			
02	C1C11-20801	Cap bearing 轴承座	2			
03	C1C11-21401	Lock washer 锁片	4			
04	C1C11-21501	Bolt 螺栓	4			
05	C1C11-02101	Case, cross L.H. 左差速器壳体	1			
06	C1C11-02201	Case, cross R.H. 右差速器壳体	1			
07	C1C11-20101	Washer 垫圈	2			
08	C1C11-22101	Gear side 半轴齿轮	2			
09	C1C11-23001	Gear shaft 齿轮轴 (I)	1			
10	C1C11-21901	Gear shaft 齿轮轴 (II)	1			
11	0B6×28	Pin 圆柱销 B6×28	1	GB/T119-2000		
-	-GB/T119					
12	C1C11-21801	Gear ,Pinion 行星齿轮	4			
13	C1C11-21701	Washer thrust 止推垫圈	4			
14	C1C11-20001	Gearwheel 大齿轮	1			
15	C1C11-22301	Bolt 螺栓	12			
16	C1C11-20401	Washer lock 锁紧垫片	6			
17	0M10×1.25 (12 级)	Nut 螺母 M10×1.25 (12 级)	12	GB/T6176-2000		
-	-GB/T6176					
18	06211-GB/T276	Bearing 轴承 6211	2	GB/T276-1994		
19	085×3.1	O ring 0 型密封圈 85×3.1	1	GB/T1235-76		
-	-GB/T1235					
20	C1C11-21601	Cap bearing 轴承座	1			
21	010-GB93	Washer 垫圈 10	16	GB93-1987		
22	0M10×25	Bolt 螺栓 M10×25	6	GB/T5783-2000		
-	-GB/T5783					

图 10 变速箱总成					TRANSMISSION ASS'Y	
序号	图号	零部件名称		件数	备注	
Item No	Part No	Description		Q'ty	Remark	
23	C1C11-20501	Gear shaft	齿轮轴	1		
24	C1C11-30401	Gear	齿轮III	1	GB93-87	
25	C1C11-20301	Shim	调整垫	1		
26	050-GB/T894.1	Washer	轴用弹性挡圈 50	1	GB/T894.1-86	
27	0NJ307E-GB/T283	Bearing	轴承 NJ307E	1	GB/T283-94	
28	032206-GB/T297	Bearing	轴承 32206	1	GB/T297-97	
29	C1C11-20901	Bushing	衬套	1		
30	C1C11-20601	Shim	调整垫	按需		
31	C1C11-21101	Nut	锁紧螺母	1		
32	062×3.1	O ring	0 型密封圈 62×3.1	1	GB/T1235-76	
-	-GB/T1235					
33	C1C11-21001	Cover	端盖	1		
34	0M10×1.25×25	Bolt	螺栓 M10×1.25×25	4	GB/T5786-2000	
-	-GB/T5786					
35	C1C11-22701	Shaft	轴	1		
36	025×2.4	O ring	0 型密封圈 25×2.4	2	GB/T1235-76	
-	-GB/T1235					
37	C1C11-22601	Gear	齿轮 (I)	1		
38	C1C11-22801	Gear	齿轮 (II)	1	HDCS30 II	
-	C1C11-22901	Gear	齿轮 (II)	1	HDCS30 II A	
39	C1C11-20701	Shim	调整垫	1		
40	C1C11-20201	Washer	挡圈	1		
41	06305-GB/T297	Bearing	轴承 6305	4	GB/T276-94	
42	C1C11-24001	Gear	输入齿轮	1	HDCS30 II	
-	C1C11-22201	Gear	输入齿轮	1	HDCS30 II A	
43	06208-GB/T297	Bearing	轴承 6208	4	GB/T276-94	



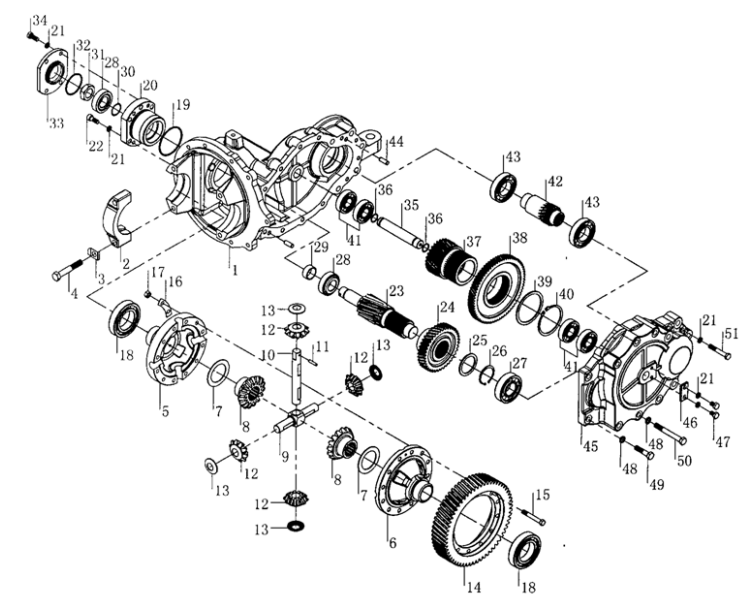
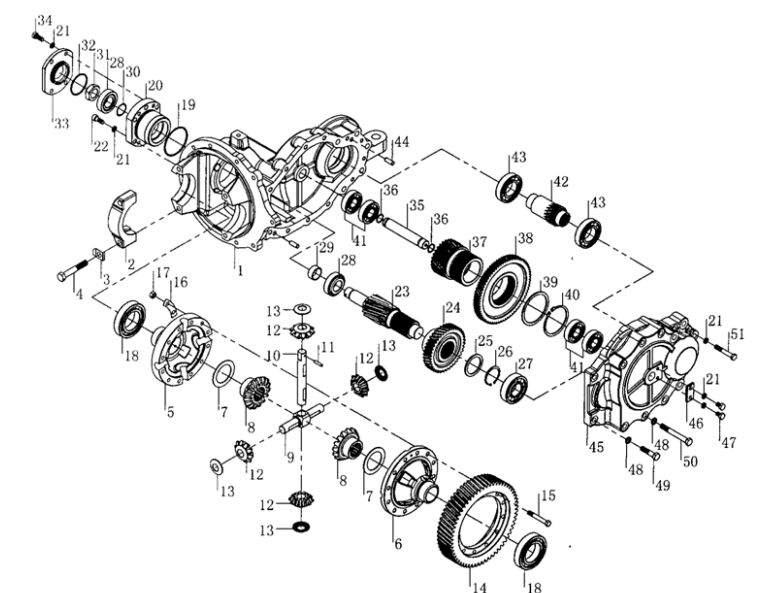
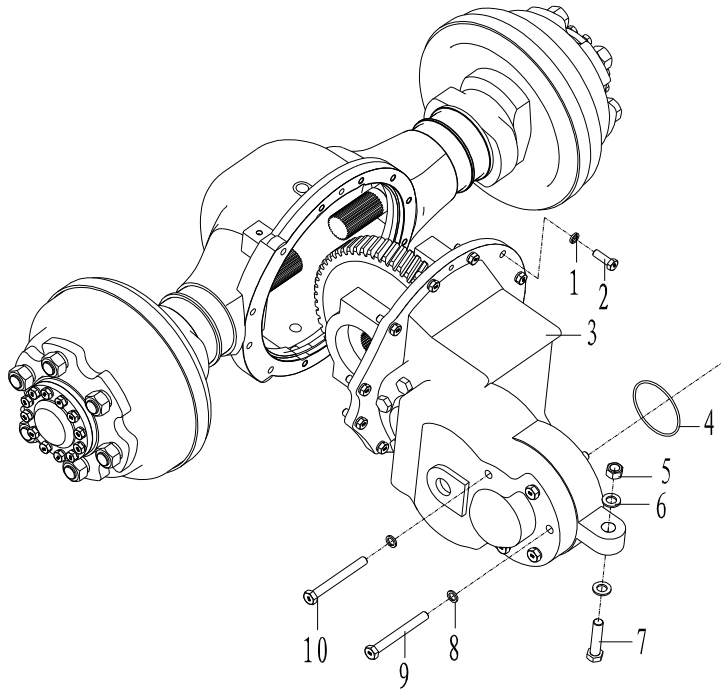

## 2. TRANSMISSION SYSTEM 传动系统

图 11		传动系统			DRIVE SYSTEM
序号	图 号	零部件名称	件数	备 注	CPD30、CPD35
Item No	Part No	Description	Q' ty	Remark	
01	012-GB93	Washer 垫圈 12	6	GB93-87	
02	0M12×1.25×35	Bolt 螺栓 M12×1.25×75	6	GB/T5783-2000	
-	-GB/T5783				
03	C1C11-02001	Gear Boxhouse 变速箱总成	1		
04	095×3.1-GB1235	Oil O型密封圈 95(外)×3.1	1	GB1235-76	
05	0M12×1.5	Nut 锁紧螺母 M12×1.5	1	GB889.2-2000	
-	-GB889.2				
06	016-GB/T97.1	Washer 垫圈 16	2	GB/T97.1-2002	
-	-GB/T5786				
07	0M16×80	Bolt 螺栓 M16×80	1	GB/T5783-2000	
-	-GB/T5783				
08	014-GB93	Washer 垫圈 14	5	GB93-87	
09	0M14×120	Bolt 螺栓 M14×120	4	GB/T5783-2000	
-	-GB/T5783				
10	0M14×155	Bolt 螺栓 M14×155	1	GB/T5783-2000	
-	-GB/T5783				

# V HOOD&FLOORBOARD 机罩与底板类

图 12 机罩与底板类					HOOD & FLOORBOARD
序号 Item No	图号 Part No	零部件名称 Description	件数 Q' ty	备注 Remark	CPD30、CPD35  
01	CDJ3D-02001	Hood 机罩装配总成	1		
02	CDJ3D-07001	Sidehood 侧罩总成(左)	1		
03	C1J11-00011	Cap 平衡重起吊盖	2		
04	CDJ1A-01011	Cap 配重盖	1		
05	08-GB/T96.1	Washer 垫圈 8	4	GB/T96.1-2002	
06	08-GB93	Washer 垫圈 8	5	GB93-87	
07	0M8×20 -GB/T5783	Bolt 螺栓 M8×20	4	GB/T5783-2000	
08	CDH2A-01011	Apron 出线胶圈	2		
09	CDJ3D-08001	Sidehood 侧罩总成(右)	1		
10	CDJ2A-14001	Seat 座椅	1		
11	CDJ3D-A0051	Board Mat 底板垫	1		
12	C1J01-06001	Buckle 搭扣总成	1		
13	0M8×10 -GB/T818	Boult 螺钉 M8×10	2	GB/T818-2000	
14	08-GB93	Washer 垫圈 8	1	GB93-87	
15	0M6×10 -GB/T818	Boult 螺钉 M6×10	8	GB818-85	
16	CDJ3D-01041	Footplate 脚踏板(左)	1		
17	CDJ3D-09001	Boult 盖板螺钉	2	GB93-1987	



# VI BRAKE SYSTEM 制动系统

## 1. SERVICE BRAKE SYSTEM 行车制动系统

图 13 行车制动装置					BRAKE CONTROL UNIT
序号 Item No	图号 Part No	零部件名称 Description	件数 Q'ty	备注 Remark	CPD30、CPD35
01	CDX3A-07001	Steel Tube 制动钢管总成(左)	1		
02	CDX2A-01011	Pipe Strap 管夹片	2		
03	CDX3A-06001	Steel Tube 制动钢管总成(右)	1		
04	0M8×25	Bolt 螺栓 M8×25	1	GB/T5783-2000	
-	-GB/T5783				
05	08-GB93	Washer 垫圈 8	1	GB93-1987	
06	08-GB/T97.1	Washer 垫圈 8	1	GB/T97.1-2002	
07	CDX2A-08001	Block Hoop 储油卡箍	1		
08	CDX2A-01031	Oil Tank 储油罐	1		
09	0Φ16-QC/T390	Block Hoop 双钢丝卡箍Φ16	2		
10	CDX2A-01021	Latex Canal 制动橡胶管	1		
11	CDX2A-02001	Service Brake 行车制动	1		
12	0M10×25	Bolt 螺栓 M10×25	4	GB/T5783-2000	
-	-GB/T5783				
13	010-GB93	Washer 垫圈 10	4	GB93-1987	
14	010-GB/T97.1	Washer 垫圈 10	4	GB/T97.1-2002	

## 2. PARKING BRAKE SYSTEM 停车制动系统

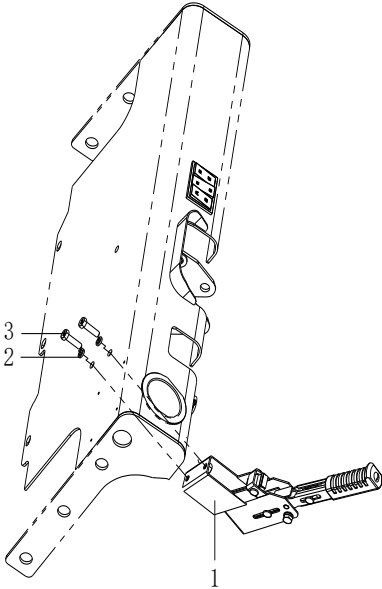
图 14 停车制动系统					PAPKING BRAKE
序号 Item No	图 号 Part No	零部件名称 Description	件数 Q' ty	备 注 Remark	CPD30、CPD35
01	CDT2A-02001	Lever, Hand Brake	1		
-		电叉手制动总成			
02	010-GB93	Washer 垫圈 10	2	GB93-1987	
03	0M10×25	Bolt 螺栓 M10×25	1	GB/T5783-2000	
-	-GB/T5783				

## VII OVERHEAD GUARD 护顶架

图 15		护顶架			OVERHEAD GUARD
序号	图 号	零部件名称	件数	备 注	CPD30、CPD35
Item No	Part No	Description	Q' ty	Remark	
01	CDH2A-02001	Overhead guard 框架总成	1		
02	CDH3D-01081	Apron 开槽胶圈 I	4		
03	CDH3D-01091	Apron 开槽胶圈 II	3		
04	012-GB/T96.1	Washer 垫圈 12	4	GB/T96.1-2002	
05	012-GB93	Washer 垫圈 12	4	GB/T5783-2000	
06	OM12×30 -GB/T5783	Bolt 螺栓 M12×30	4	GB93-1987	
07	OM16×45 -GB/T5783	Bolt 螺栓 M16×45	4	GB/T5783-2000	
08	016-GB/T97.1	Washer 垫圈 16	4	GB/T97.1-2002	
09	016-GB93	Washer 垫圈 16	4	GB93-87	
10	OM16×1.5 -GB/T6171	Bolt 螺母 M16×1.5	4	GB/T6171-2000	
11	OM16×35 -GB/T5783	Bolt 螺栓 M16×35	2	GB/T5783-2000	
12	016-GB93	Washer 垫圈 16	2	GB93-87	
13	016-GB/T97.1	Washer 垫圈 16	2	GB/T97.1-2002	
14	CDH2A-01061	mirror 后视镜	1		
15	CDH3A-01051	mirror lamp 后视镜支架	1		
16	CDH2A-01031	Decoratetop 饰盖	4		
17	08-GB/T97.1	Washer 垫圈 8	1	GB/T97.1-2002	
18	08-GB93	Washer 垫圈 8	1	GB93-87	
19	OM8×20 -GB5783	Bolt 螺栓 M8×20	1	GB/T5783-2000	
20	CDH3D-07001	Trestle 前灯罩总成(右)	1		

图 15 护顶架					OVERHEAD GUARD
序号 Item No	图 号 Part No	零部件名称 Description	件数 Q' ty	备 注 Remark	CPD30、CPD35
21	CDH3D-08001	Trestle 前灯架总成(左)	1		
22	0M5×14 -GB17880	Nut 柳螺母 M5×14	4	GB17880.2	
23	0M6×16.5 -GB17880	Nut 柳螺母 M6×16.5	2	GB17880.2	

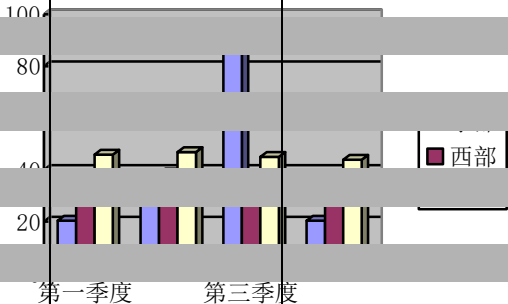

# VIII STEERING SYSTEM 转向系统

图 16		转向系统			STEERING SYSTEM
序号	图 号	零部件名称	件数	备 注	CPD30、CPD35
Item No	Part No	Description	Q' ty	Remark	
01	CDE2A-06001	Steering Wheel $\Phi 300$ 方向盘	1		
02	CDE3D-02001	Steering Column 转向管柱总成	1		
03	CDE2A-01041	Rubber Mat 橡胶垫 01	4		
04	CDE2A-01051	Bolt 螺栓(左旋)	1		
05	CDE2A-01061	Casing 套管 02	1		
06	CDE2A-02071	Cardan Joint 万向节	1		
07	CDE2A-01011	Sheath 护套	1		
08	CDE2A-03001	Shaft 连接轴总成	1		
09	010-GB93	Washer 垫圈 10	2	GB93-1987	
10	0M10×25	Bolt 螺栓 M10×25	2	GB/T5782-2000	
-	-GB/T5782				
11	CDE2A-01101	Bolt 螺栓	2		
12	014-GB/T97.1	Washer 垫圈 14	2	GB/T97.1-2002	
13	CDE2A-01091	Washer 垫圈 01	2		
14	CDE2A-01081	Bolt 螺栓 M10×16 左旋	1		
15	010-GB/T96.1	Washer 垫圈 10	1	GB/T96.1-2002	
16	COE2A-02401	Handle 手柄总成	1		
17	CDE2A-01071	Nut 螺母(左旋)	1		

IX ELECTRIC SYSTEM 电气系统

图 16 电气系统					ELECTRIC SYSTEM
序号 Item No	图 号 Part No	零部件名称 Description	件数 Q' ty	备 注 Remark	CPD30、CPD35  
A	CDD3D-A1001	Electric System 电气系统			
01	CDD3D-01001	Electric System 电气系统	1	标配 inmotion 控制系统	
-					
02	CDD3D-B1001	Electric System 电气系统	1	选配 Curtis 控制系统	
-					

图 16		电气系统			ELECTRIC SYSTEM	
序号	图 号	零部件名称	件数	备 注	CPD30、CPD35	
Item No	Part No	Description	Q' ty	Remark		
A	CDD3D-01001	Electric System 电气系统	1	标配inmotion		
01	CDD3D-32002	BC Principle Diagram 半交流电气原理图	1			
-	CDD3D-32003	AC Principle Diagram 全交流电气原理图	1			
02	CDD3D-70001	Control Assembly Drawing 电控装配图	1			
03	CDD3D-71001	Traction Motor Assembly Drawing 行走电机装配图	1			
04	CDD3D-72001	Pump Motor Assembly Drawing 起升电机装配图	1			
05	CDD3D-73001	Cable Assembly Drawing 线束装配图	1			
06	CDD3D-74001	Power Assembly Drawing 电源装配图	1			
07	CDD3D-75001	Assembly Drawing Of Power Socket Assembly 电源插座总成装配图	1			
08	CDD3D-76001	Electrical Parts Assembly Drawing Of The Shield 护顶架电气部件装配图	1			
09	CDD3D-77001	12V Parts Assembly Drawing 12V 部件装配图	1			
10	CDD3D-78001	Brake Electric Parts Assembly Drawing 制动电气部件装配图	1			







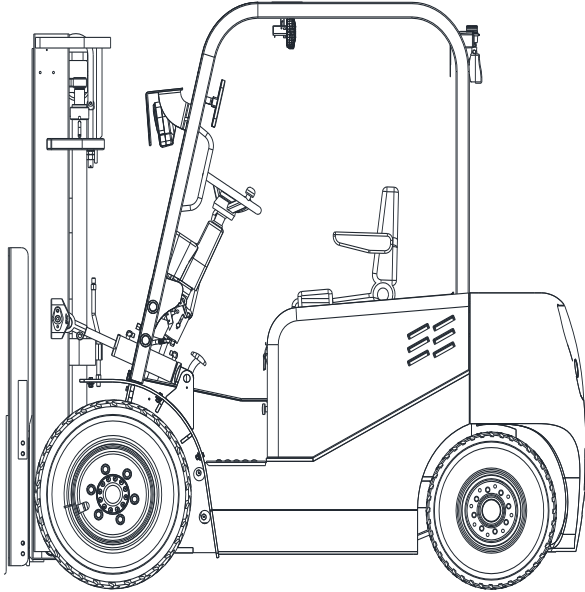

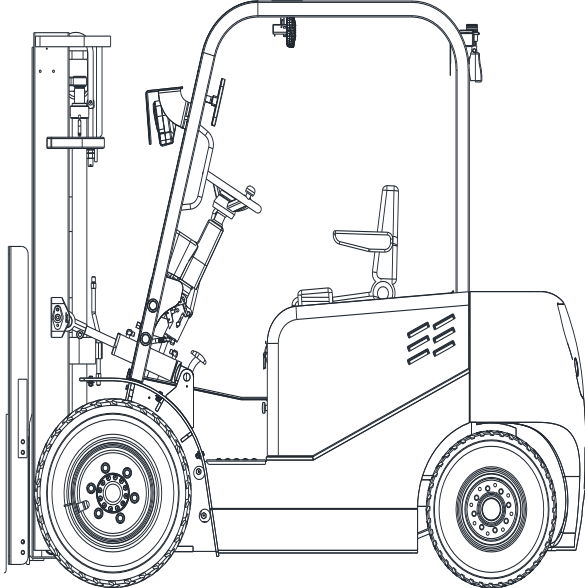

图 16		电气系统			ELECTRIC SYSTEM	
序号	图 号	零部件名称	件数	备 注	CPD30、CPD35	
Item No	Part No	Description	Q' ty	Remark		
A	CDD3D-06002	A/D Control Unit	1			
-		半交流电控总成				
01	CDD3D-06012	Baseplate 底板	1			
02	CDD3D-06022	AC Traction Controller	1			
-		交流牵引控制器				
03	CDD3D-06072	Control Lead Outlet	1			
-		电控引出线				
04	CDD3D-06042	Pump Fuse Assembly	1			
-		泵熔断器总成				
05	CDD3D-06032	DC Pump Controller	1			
-		直流泵控制器				
06	CDD3D-06052	Contactoer Assembly	1			
-		接触器总成				
07	CDD3D-06062	Traction Fuse Assembly	1			
		牵引熔断器总成				

图 16 电气系统					ELECTRIC SYSTEM
序号	图 号	零部件名称	件数	备 注	CPD30、CPD35
Item No	Part No	Description	Q' ty	Remark	
A	CDD3D-06003	AC Control Unit 交流电控总成	1		
01	CDD3D-06013	Baseplate 底板	1		
02	CDD3D-06022	AC Traction Controller	1		
-		交流牵引控制器			
03	CDD3D-06073	Control Lead Outlet	1		
-		电控引出线			
04	CDD3D-06033	AC Pump Controller	1		
-		交流泵控制器			
05	CDD3D-06042	Pump Fuse Assembly	1		
-		泵熔断器总成			
06	CDD3D-06052	Contactors Assembly	1		
-		接触器总成			
07	CDD3D-06062	Traction Fuse Assembly	1		
		牵引熔断器总成			

图 16		电气系统			ELECTRIC SYSTEM	
序号	图 号	零部件名称	件数	备 注	CPD30、CPD35	
Item No	Part No	Description	Q' ty	Remark		
A	CDD3D-71001	Traction Motor Assembly	1			
-		Drawing 行走电机装配图				
01	CDD3A-03001	AC Traction Motor	1			
-		交流行走电机				
-	CDD3A-03011	AC Traction Motor	1			
-		交流行走电机				
02	014-GB/T93	Washer 弹簧垫圈 14	5	GB93-87		
03	0M14×1.5×120-					
-	-GB/T5783	Bolt 螺栓 M14×1.5×120	3	GB/T5783-2000		
04	0M14×1.5×155-					
-	-GB/T5783	Bolt 螺栓 M14×1.5×155	2	GB/T5783-2000		



图 16		电气系统			ELECTRIC SYSTEM	
序号	图 号	零部件名称	件数	备 注	CPD30、CPD35	
Item No	Part No	Description	Q' ty	Remark		
A	CDD3D-73001	Cable Assembly Drawing	1			
-		线束装配图				
01	CDD3D-07002	AC/DC Frame Cable	1			
-		半交流车身线束				
-	CDD3D-07003	AC Frame Cable	1			
-		全交流车身线束				
02	CDD3D-91001	Cab Cable	1			
		驾驶室过渡线				
03	CDD3D-92001	Warm Air Blower Cable	1			
-		暖风机过渡线				
04	CDD3D-93001	Safety Belt Switch Cable	1			
-		安全带开关过渡线				
05	CDD3D-99001	Harness Fixing Card	4			
-		线束固定卡				

图 16 电气系统					ELECTRIC SYSTEM
序号 Item No	图 号 Part No	零部件名称 Description	件数 Q' ty	备 注 Remark	CPD30、CPD35
A	CDD3D-74001	Power Assembly Drawing 电源装配图	1		
-					
01	CDD3D-A0011	Battery List 蓄电池组清单	1		
02	CDD3D-A0021	Charger List 充电机清单	1		

图 16		电气系统			ELECTRIC SYSTEM	
序号	图 号	零部件名称	件数	备 注	CPD30、CPD35	
Item No	Part No	Description	Q' ty	Remark		
A	CDD3D-A0011	Battery List 蓄电池组清单	1			
01	CDD3D-B1011	Battery 蓄电池	1	3t 标配 500Ah		
02	CDD3D-B1021	Battery 蓄电池	1	3.5t 标配 550Ah		
03	CDD3D-B1031	Battery 蓄电池	1	选配好牌 500Ah		
04	CDD3D-B1041	Battery 蓄电池	1	选配 GS 500Ah		
05	CDD3D-B1051	Battery 蓄电池	1	选配 600Ah		
06	CDD3D-B1061	Battery 蓄电池	1	选配 650Ah		
07	CDD3D-B1071	Battery 蓄电池	1	选配好牌 560Ah		
08	CDD3D-B1081	Battery 蓄电池	1	FAAM 500Ah		
09	CDD3D-B1091	Battery 蓄电池	1	Selective 选配		
10	CDD3D-B1101	Battery 蓄电池	1	Selective 选配		
11	CDD3D-B1111	Battery 蓄电池	1	Selective 选配		
12	CDD3D-B1121	Battery 蓄电池	1	Selective 选配		
13	CDD3D-B1131	Battery 蓄电池	1	Selective 选配		
14	CDD3D-B1141	Battery 蓄电池	1	Selective 选配		

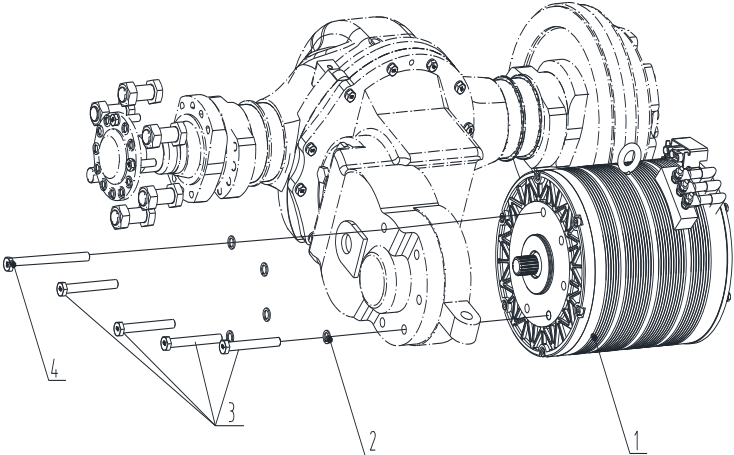
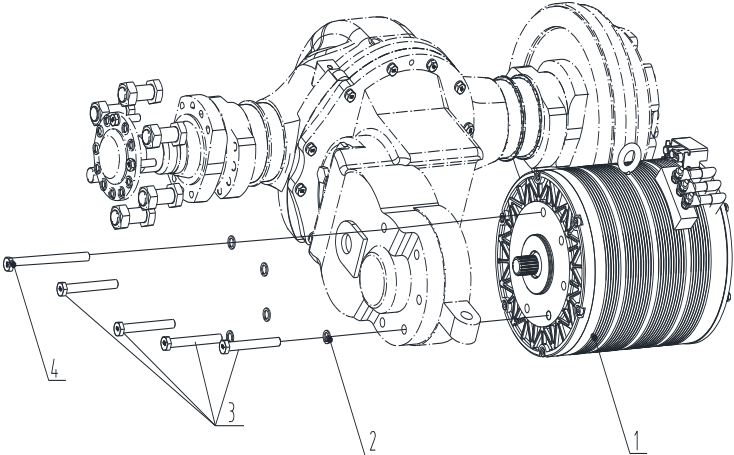
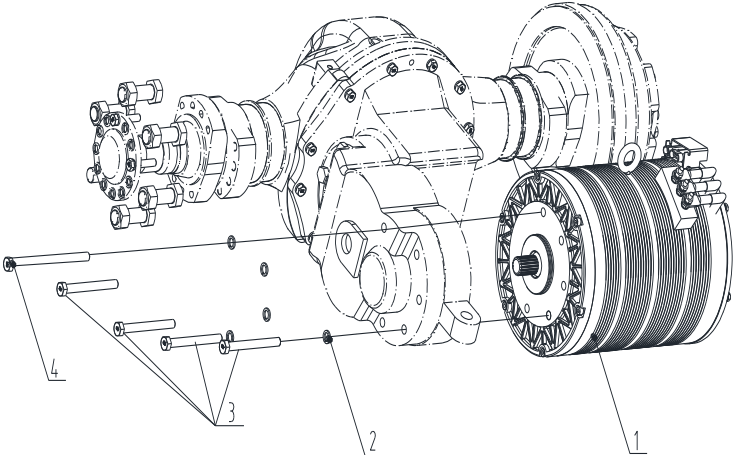
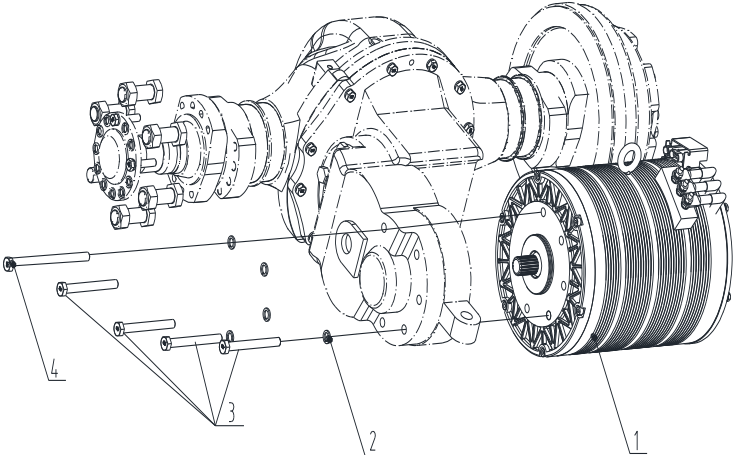
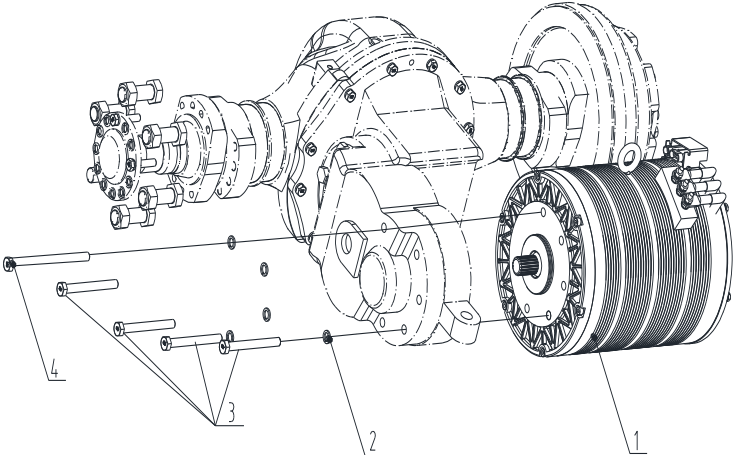
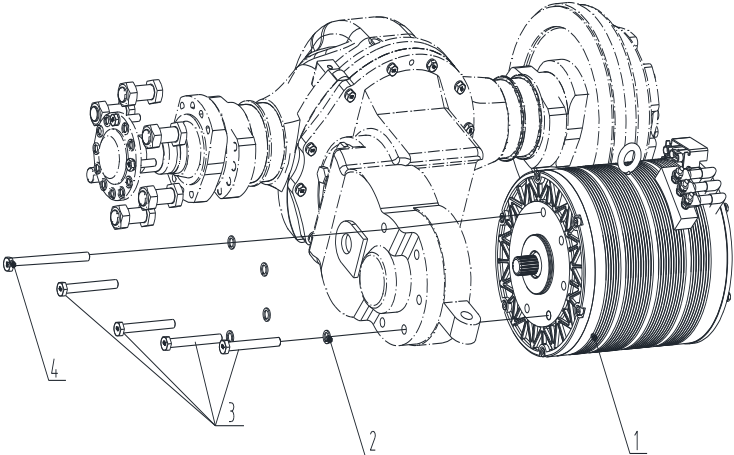
图 16		电气系统			ELECTRIC SYSTEM	
序号	图 号	零部件名称		件数	备 注	CPD30、CPD35
Item No	Part No	Description		Q' ty	Remark	
A	CDD3D-A0021	Charger List	充电机清单	1		
01	CDD3D-B2011	Charge	充电机	1	标配 80V70A	
02	CDD3D-B2021	Charge	充电机	1	选配德龙	
03	CDD3D-B2031	Charge	充电机	1	华为 80V80A	
04	CDD3D-B2041	Charge	充电机	1	华为 80V90A	
05	CDD3D-B2051	Charge	充电机	1	选配德龙	
06	CDD3D-B2061	Charge	充电机	1	选配德龙	
07	CDD3D-B2071	Charge	充电机	1	选配嘉昌	
08	CDD3D-B2081	Charge	充电机	1	选配嘉昌	
09	CDD3D-B2091	Charge	充电机	1	选配嘉昌	
10	CDD3D-B2101	Charge	充电机	1	Selective 选配	
11	CDD3D-B2111	Charge	充电机	1	Selective 选配	
12	CDD3D-B2121	Charge	充电机	1	Selective 选配	
13	CDD3D-B2131	Charge	充电机	1	Selective 选配	
14	CDD3D-B2141	Charge	充电机	1	Selective 选配	
15	CDD3D-B2151	Charge	充电机	1	Selective 选配	
16	CDD3D-B2161	Charge	充电机	1	Selective 选配	
17	CDD3D-B2171	Charge	充电机	1	Selective 选配	
18	CDD3D-B2181	Charge	充电机	1	Selective 选配	
19	CDD3D-B2191	Charge	充电机	1	Selective 选配	
20	CDD3D-B2201	Charge	充电机	1	Selective 选配	
21	CDD3D-B2211	Charge	充电机	1	Selective 选配	





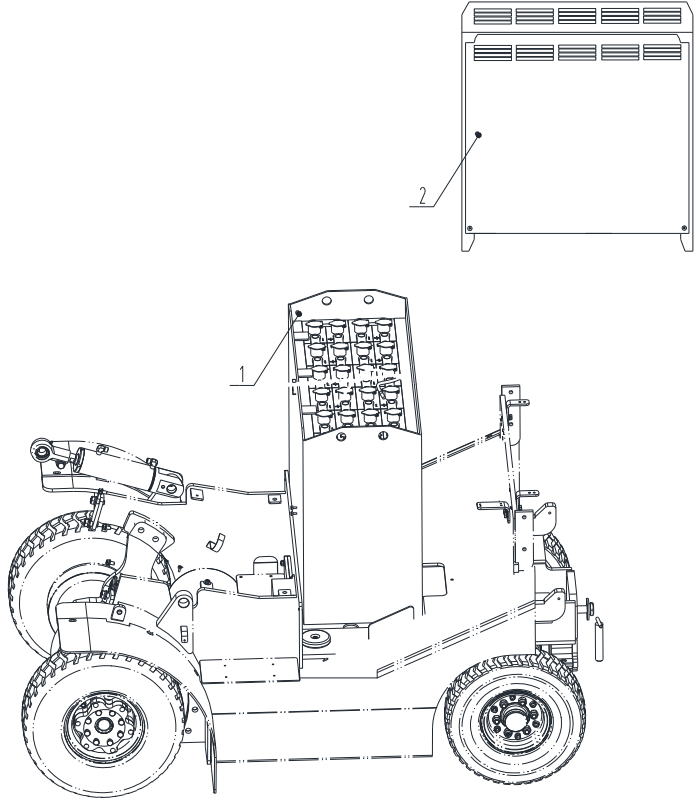

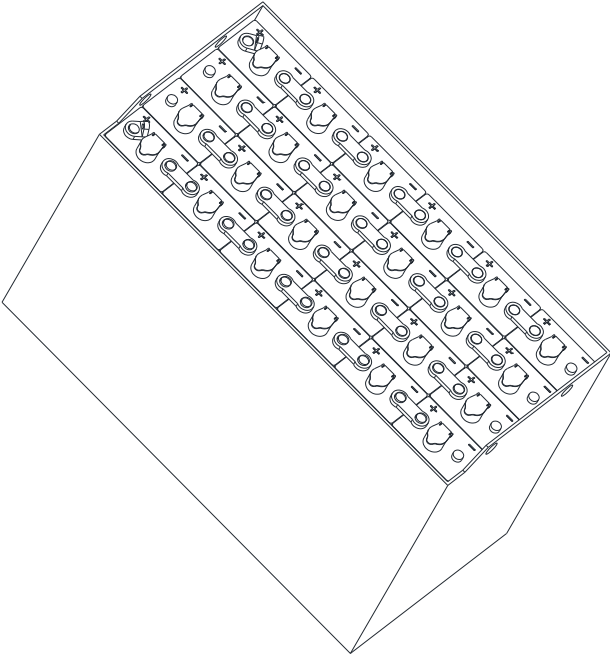
图 16		电气系统			ELECTRIC SYSTEM	
序号	图 号	零部件名称	件数	备 注	CPD30、CPD35	
Item No	Part No	Description	Q' ty	Remark		
A	CDD3D-77001	12V Parts Assembly Drawing	1			
-		12V 部件装配图				
01	CDD3D-19001	Fusebox 保险丝盒	1			
02	CDD3D-11001	DC-DC DC 转换器	1			
03	05-GB/T97.1	Washer 垫圈 5	4	GB/T97.1-2002		
04	05-GB/T93	Washer 垫圈 5	4	GB93-87		
05	0M5×15-GB/T818	Screw 螺钉 M5×15	4	GB/T818-2000		
06	CDD3D-21001	Flash Unit 电子闪光灯	1			
07	CDD2A-20001	Reverse Buzzer 倒车蜂鸣器	1			
-	CDD2A-20011	Speech Reverse Buzzer	1	Selective 选配		
-		语音倒车蜂鸣器				
08	06-GB/T97.1	Washer 垫圈 6	4	GB/T97.1-2002		
09	06-GB/T93	Washer 垫圈 6	4	GB93-87		
10	0M6×12-GB/T818	Screw 螺钉 M6×12	1	GB/T818-2000		
11	0M6×16-GB/T818	Screw 螺钉 M6×16	3	GB/T818-2000		
12	CDD2A-16001	Horn 喇叭	1			
13	08-GB/T97.1	Washer 垫圈 8	1	GB/T97.1-2002		
14	08-GB/T93	Washer 垫圈 8	1	GB93-87		
15	0M8×15-GB/T5783	Bolt 螺栓 M8×15	1	GB/T5783-2000		
16	CDD3D-22001	Horn Filter 喇叭滤波器	1			
17	04-GB/T93	Washer 垫圈 4	1	GB93-87		
18	0M4×10-GB/T818	Screw 螺钉 M4×10	1	GB/T5783-2000		
19	CDD3A-40001	Safety Belt Alarm 安全带报警	1	Selective 选配		

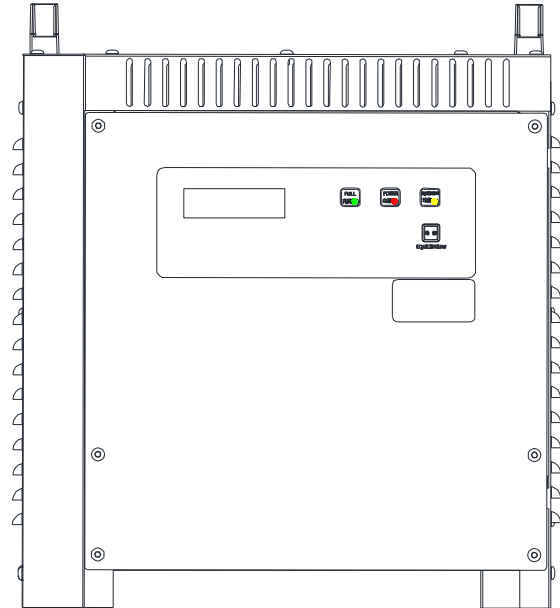

图 16		电气系统			ELECTRIC SYSTEM	
序号	图 号	零部件名称	件数	备 注	CPD30、CPD35	
Item No	Part No	Description	Q' ty	Remark		
A	CDD3D-79001	Covering Parts Assembly	1			
-		Drawing 覆盖件电气部件装配图				
01	CDD3D-84001	Triple False Plate 三联假板	1			
02	CDD3D-89001	USB Charger USB 充电器	1			
03	CDD2A-10001	Power Source SW 总电源开关	1			
04	CDD3D-86001	Lighting Switches	1	Selective 选配		
-		照明翘板开关				
05	CDD3D-85001	Fan Rocker Switch	1	Selective 选配		
-		风扇翘板开关				
06	CDD3D-39001	Wiper Switch 雨刮器开关	1	Selective 选配		
07	CDD3D-94001	Fan Rocker Switch Cable	1	Selective 选配		
-		风扇翘板开关过渡线				
08	CDD3D-95001	Fan/Wiper Rocker Switch Cable	1	Selective 选配		
-		风扇、雨刮翘板开关过渡线				
09	CDD3D-45001	Warm Air Blower 暖风机	1	Selective 选配		
10	OM6×55	Bolt 螺栓 M6×55	4	GB/T5783-2000		
-	-GB/T5783					
11	O6-GB/T93	Washer 垫圈 6	4	GB93-87		
12	O6-GB/T97.1	Washer 垫圈 6	4	GB/T97.1-2002		
13	OM6-GB/T6170	Nut 螺母 M6	4	GB/T6170-2000		



图 16		电气系统			ELECTRIC SYSTEM	
序号	图 号	零部件名称	件数	备 注	CPD30、CPD35	
Item No	Part No	Description	Q' ty	Remark		
A	CDD3D-80001	Accelerator Assembly Drawing	1			
-		加速器装配图				
01	CDD3D-12001	Accelerator 加速器	1			
02	0M8×25	Bolt 螺栓 M8×25	2	GB/T5783-2000		
-	-GB/T5783					
03	08-GB/T97.1	Washer 垫圈 8	2	GB/T97.1-2002		
04	08-GB/T93	Washer 弹簧垫圈 8	2	GB93-87		
05	0M8-GB/T6170	Nut 螺母 M8	2	GB/T6170-2000		

图 16 电气系统					ELECTRIC SYSTEM
序号	图 号	零部件名称	件数	备 注	CPD30、CPD35
Item No	Part No	Description	Q' ty	Remark	
A	CDD3D-81001	Valve Electric Parts	1		
-		Assembly Drawing			
-		多路阀电气部件装配图			
01	CDD3D-A0001	Lift SW 起升开关	1		
02	CDD3D-55001	Lifting Speed Sensor 起升调速传感器	1		
-					

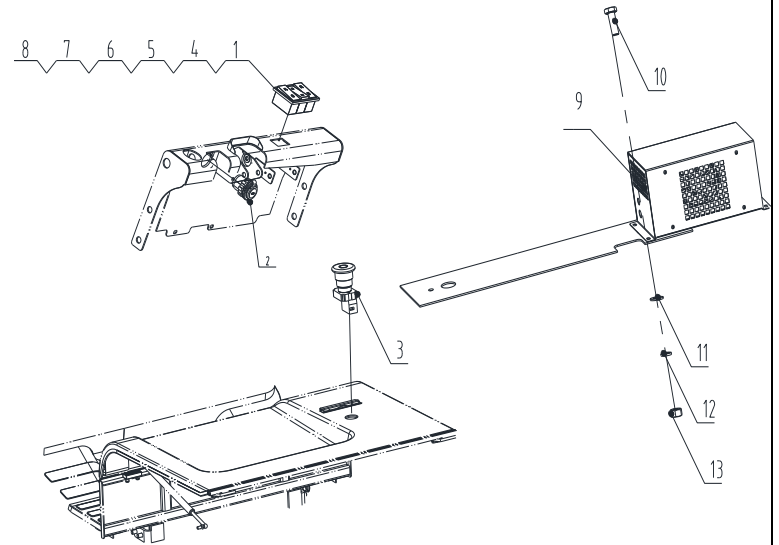

图 16		电气系统			ELECTRIC SYSTEM	
序号	图 号	零部件名称	件数	备 注	CPD30、CPD35	
Item No	Part No	Description	Q' ty	Remark		
A	CDD3D-83001	Forceful Electric Power	1			
-		Assembly Drawing 强电装配图				
01	CDD3D-64001	AC Travel Motor Cable	1			
-		交流行走电机 U 线				
02	CDD3D-65001	AC Travel Motor Cable	1			
-		交流行走电机 V 线				
03	CDD3D-66001	AC Travel Motor Cable	1			
-		交流行走电机 W 线				
04	CDD3D-33001	Water Proof 防水烟斗	8			
05	CDD2A-42001	Magnet ring 行走磁环	12	国际标配		
06	CDD3D-67001	AC Pump Motor Cable	1			
-		交流起升电机 U 线				
07	CDD3D-68001	AC Pump Motor Cable	1			
-		交流起升电机 V 线				
08	CDD3D-69001	AC Pump Motor Cable	1			
-		交流起升电机 W 线				
09	OM8×25	Bolt 不锈钢螺栓 M8×25	2	GB/T3098.6-		
-	-GB/T3098.6			2000		
10	O8-GB/T97.1	Washer 垫圈 8	2	GB/T97.1-2002		
11	O8-GB/T93	Washer 弹簧垫圈 8	2	GB93-87		
12	OM8-GB/T3098.15	Nut 不锈钢螺母 M8	2	GB/T3098.15		
				-2000		

图 16		电气系统			ELECTRIC SYSTEM	
序号	图 号	零部件名称	件数	备 注	CPD30、CPD35	
Item No	Part No	Description	Q' ty	Remark		
A	CDD3D-B1001	Electric System 电气系统	1	选配Curtis		
01	CDD3A-67002	BC Principle Diagram 半交流电气原理图	1			
-	CDD3A-68002	AC Principle Diagram 全交流电气原理图	1			
02	CDD3D-70002	Control Assembly Drawing 电控装配图	1			
03	CDD3D-71001	Traction Motor Assembly Drawing 行走电机装配图	1			
04	CDD3D-72001	Pump Motor Assembly Drawing 起升电机装配图	1			
05	CDD3D-73002	Cable Assembly Drawing 线束装配图	1			
06	CDD3D-74001	Power Assembly Drawing 电源装配图	1			
07	CDD3D-75001	Assembly Drawing Of Power Socket Assembly 电源插座总成装配图	1			
08	CDD3D-76001	Electrical Parts Assembly Drawing Of The Shield 护顶架电气部件装配图	1			
09	CDD3D-77001	12V Parts Assembly Drawing 12V 部件装配图	1			
10	CDD3D-78001	Brake Electric Parts Assembly Drawing 制动电气部件装配图	1			

图 16		电气系统			ELECTRIC SYSTEM			
序号	图 号	零部件名称	件数	备 注	CPD30、CPD35			
Item No	Part No	Description	Q' ty	Remark				
11	CDD3D-79001	Covering Parts Assembly	1					
-		Drawing 覆盖件电气部件装配图						
12	CDD3D-80002	Accelerator Assembly Drawing	1					
-		加速器装配图						
13	CDD3D-81001	Valve Electric Parts	1					
-		Assembly Drawing						
-		多路阀电气部件装配图						
14	CDD3D-82002	Steering Column Electric	1					
-		Parts Assembly Drawing						
-		转向管柱电气部件装配图						
15	CDD3D-83002	Forceful Electric Power	1					
-		Assembly Drawing 强电装配图						





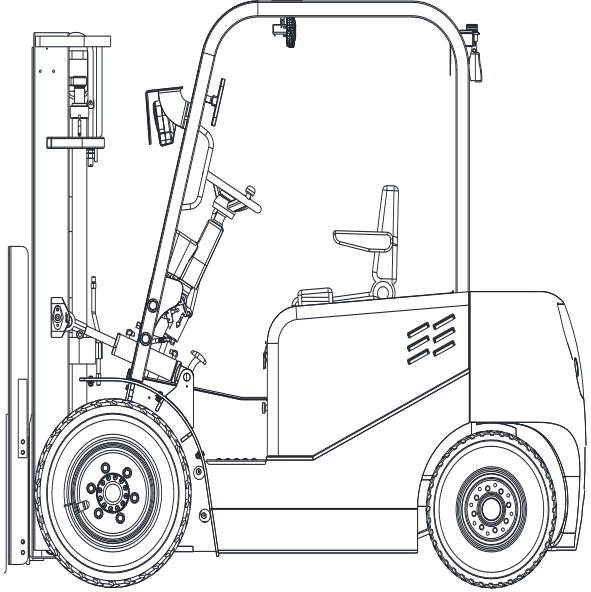

图 16		电气系统			ELECTRIC SYSTEM	
序号	图 号	零部件名称	件数	备 注	CPD30、CPD35	
Item No	Part No	Description	Q' ty	Remark		
A	CDD3A-06002	A/D Control Unit	1	选配 Curtis		
-		半交流电控总成				
01	CDD3A-06012	Traction Controller 牵引电控	1			
02	CDD3A-06192	T Main Contactor 牵引主接触器	1			
03	CDD3A-06062	T Fuse 牵引电控保险丝	1			
04	CDD3A-06182	Fuse 保险丝	1			
05	CDD3A-06112	P Fuse 泵电控保险丝	1			
06	CDD3A-06032	P Main Contactor 泵主接触器	1			
07	CDD3A-06132	Pump Controller 泵电控	1			
08	CDD3A-06121	Cable 过渡线	1			
09	CDD3A-33001	Water Proof 防水烟斗	17			
10	CDD3A-06171	Baseplate 底板	1			

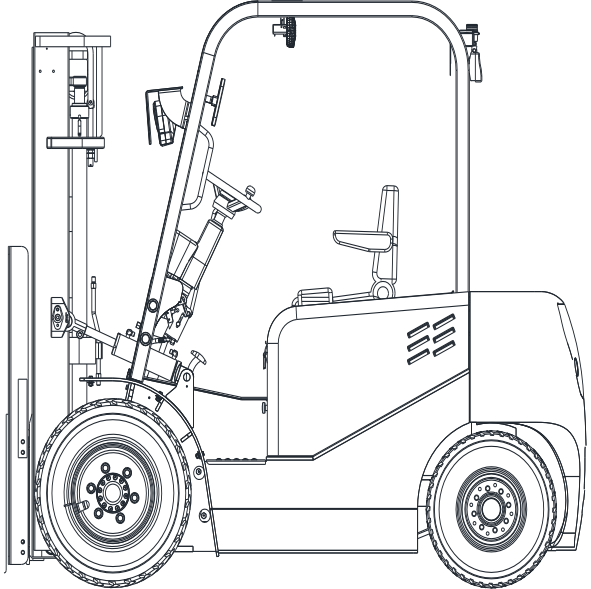



图 16		电气系统			ELECTRIC SYSTEM		
序号	图 号	零部件名称	件数	备 注	CPD30、CPD35		
Item No	Part No	Description	Q' ty	Remark			
A	CDD3D-80002	Accelerator Assembly Drawing 加速器装配图	1	选配 Curtis			
01	CDD3A-12001	Accelerator 加速器	1				
02	0M8×25	Bolt 螺栓 M8×25	2	GB/T5783-2000			
-	-GB/T5783						
03	08-GB/T97.1	Washer 垫圈 8	2	GB/T97.1-2002			
04	08-GB/T93	Washer 弹簧垫圈 8	2	GB93-87			
05	0M8-GB/T6170	Nut 螺母 M8	2	GB/T6170-2000			

图 16		电气系统			ELECTRIC SYSTEM	
序号	图 号	零部件名称	件数	备 注	CPD30、CPD35	
Item No	Part No	Description	Q' ty	Remark		
A	CDD3D-82002	Steering Column Electric	1	选配 Curtis		
-		Parts Assembly Drawing				
-		转向管柱电气部件装配图				
01	CDD3D-28002	Meter ass'y 仪表总成	1			
02	CDD3D-18001	Combination SW 组合开关	1			
03	OM6×35-GB/T5783	Bolt 螺栓 M6×35	4	GB/T5783-2000		
04	CDE2A-01021	Shim 垫片 01	4			
05	CDE2A-01031	Bushing 套管 01	4			
06	CDE2A-01041	Rubber Pad 橡胶垫 01	4			



# X HYDRAULIC SYSTEM 液压系统

## 1. HYDRAULIC SYSTEM 液压系统

图 18 液压系统					HYDRAULIC SYSTEM
序号 Item No	图号 Part No	零部件名称 Description	件数 Q' ty	备注 Remark	CPD30、CPD35
01	CDK3B-A0041	Multi-way valve & Steering Unit 多路阀转向器预装图	1		
-					
02	CDK3B-13001	Steel Pipe Ass'y 倾斜钢管总成	1		
03	CDK3B-A0061	Valve Control Ass'y 阀操纵总成	1		
04	CDK3B-06001	Hose H. P. 倾斜高压胶管 I	2		
05	CDK3B-07001	Hose H. P. 倾斜高压胶管 II	2		
06	CBM2A-A0171	Tilting Cylinder 倾斜缸总成	2		
07	CDK3B-A7011	Hose L. P. 多路阀回油管 I	1		
08	0d50-JB/T8870	Clip 蜗轮蜗杆卡箍 $\Phi 32-50$	6	JB/T 8870-1999	
09	CDK3B-02001	Steel Pipe Ass'y 回油钢管总成	1		
10	0M8-GB6170	Nut 螺母 M8	3	GB6170-85	
11	08-GB93	Washer 垫圈 8	3	GB93-87	
12	08-GB/T97.1	Washer 垫圈 8	3	GB/T97.1-2002	
13	CDK3B-03001	Hydraulic Tank 液压油箱	1		
14	CDK3B-01021	Hose L. P. 多路阀回油管 II	1		
15	CDK3A-13001	Hose L. P. 转向器回油管	1		
16	0d20-JBT8870	Clip 蜗轮蜗杆卡箍 $\Phi 12-20$	AR	JB/T 8870-1999	
17	CDK3B-01031	Hose L. P. 齿轮泵吸油管	1		
18	CDK3B-08001	Gear Pump Ass'y 齿轮泵预装图	1		
19	CDK3B-12001	Hose H. P. 多路阀供油高压胶管	1		
20	0TBA-007	Contact M16-M16 直通接头	2		
21	CDK3A-04001	Hose H. P. 转向高压胶管	2		
22	CDK3A-14001	Hose L. P. 门架回油管	AR		

## 2. MULTI-WAY VALVE & STEERING UNIT ASS`Y 多路阀转向器预装图

图 18 多路阀转向器预装图					MULTI-WAY VALVE & STEERING UNIT ASS`Y
序号 Item No	图 号 Part No	零部件名称 Description	件数 Q' ty	备 注 Remark	CPD30、CPD35
01	CDK2A-A0031	Multi-way Valve 多路阀	1		
02	016-JB982	Washer 组合垫圈 16	1	JB982-77	
03	CDK2A-39001	Contact M16 回油接头	1		
04	0d20-JBT8870	Clip 蜗轮蜗杆卡箍 Φ12-20	2	JB/T 8870-1999	
05	CDK2A-21011	Hose L.P. 转向器回油管	1		
06	CDK2A-20001	Steering Unit 转向器	1		
07	0TBA-023	Contact 回油接头	1		
08	0TBA-003	Contact M20-M16 直通接头	5		
09	CDK2A-18002	Hose H.P. 转向器供油高压胶管	1		
10	0TBA-005	Contact M12-M16 直通接头	1		
11	CDK2A-19003	Hose H.P. LS 高压胶管	1		
12	0TBA-053	Contact M12-M16K 直角接头	1		
13	0TBA-110	Contact M22-M22 135°	1		
14	0TBA-001	Contact M20-M22 直通接头	1		
15	0TBA-013	Contact M20-M16 直角接头 II	AR		
16	0TBA-011	Contact M20-M16 直角接头 I	AR		

### 3..GEER PUMP ASS`Y 多路阀转向器预装图

图 18		齿轮泵预装图			GEAR PUMP ASS`Y	
序号	图 号	零部件名称	件数	备 注	CPD30、CPD35	
Item No	Part No	Description	Q' ty	Remark		
01	OTBA-025	Contact M22-M22 直通接头	1			
02	CDK3B-09001	Gear Pump 齿轮泵	1			
03	OTBA-050	Contact M33×2 回油直角接头	1			

#### 4. VALVE CONTROL LINKAGE 阀操纵总成

图 19		阀操纵总成			VALVE CONTROL LINKAGE	
序号	图 号	零部件名称	件数	备 注	CPD30、CPD35	
Item No	Part No	Description	Q' ty	Remark		
01	C2K3A-A0051	Operating Handle 操纵手柄	AR			
02	CDK3B-A0031	Operating Stick 操纵杆	AR			
03	C2K3A-A0061	Pin Ass `y 销轴总成	1			
04	0M6×12-GBT5783	Bolt 螺栓 M6×12	1	GB/T5783-2000		
05	06-GB93	Washer 垫圈 6	1	GB93-87		
06	C2K3A-25051	Washer 垫片	4			
07	CDK2A-06021	Adjusting Sleeve 调节套	AR			
08	CDK2A-06011	Link Bar 连接杆	AR			
09	C2K3A-25061	Pin 销轴	AR			
10	02×12-GBT91	Pin , cotter 开口销 2×12	AR	GB/T91-2000		
11	05-GBT97.1	Washer 垫圈 5	AR	GB/T 97.1-2002		
12	0M10×1.25×25	Bolt 螺栓 M10×1.25×25	3	GB/T5786-2000		
-	-GB/T5786					
13	010-GB93	Washer, lock 垫圈 10	3	GB93-87		

## 5. HYDRAULIC TANK 工作油箱

图 20		工作油箱			HYDRAULIC TANK	
序号	图 号	零部件名称	件数	备 注	CPD30、CPD35	
Item No	Part No	Description	Q' ty	Remark		
01	CDK3B-04001	Tank 油箱焊接总成	1			
02	C2K3A-33001	Filter 吸油滤清器	1			
03	0112×3.55- - GB/T3452.1	O-ring 0形圈 112(内)×3.55	1	GB/T3452.1		
04	CDK3B-05001	Cover plate 油箱盖板总成	1			
05	08-GB97.1	Washer 垫圈 8	6	GB/T97.1-2002		
06	08-GB93	Washer 垫圈 8	6	GB93-87		
07	0M8×20-GBT5783	Bolt 螺栓 M8×20	1	GB/T5783-2000		
08	0d20-JBT8870 - GB/T3452.1	Clip 蜗轮蜗杆卡箍 Φ12-20	1	JB/T 8870-1999		
09	OTLN-057	Buffer pot 缓冲壶	1			
10	C1K3A-32001	Breather 呼吸器	1			
11	C1K3A-30021	Hose 封头套管	AR			
12	CDK3A-12001	Oil gauge 油标尺	1			
13	C2K3A-39001	Filter 回油滤芯	1			
14	C1F3A-03071	Magnet 磁铁 Φ68×Φ34×14	1			
15	020-JBT982	Washer 组合垫圈 20	1	JB982-77		
16	C1F3A-03021	Drain plug 放油螺塞	1			

## 6. POWER CYLINDER 转向油缸

图 21		转向油缸 (JAC-025)			POWER CYLINDER (JAC-025)
序号	图 号	零部件名称	件数	备 注	CPD30、CPD35
Item No	Part No	Description	Q' ty	Remark	
01	0d80×3.1	O-ring 0 形圈 d80×3.1	1	GB/T1235-1976	
-	-GB/T1235				
02		Sealing ring 活塞杆密封圈 50×60×6	4		
03	050×60×3	Snap ring 挡圈 50×60×3	2	GB/T1235-1976	
-	-GB/T1235				
04	0d50×3.55	O-ring 0 形圈 d50×3.55	2	GB/T3452.1-2005	
-	-GB/T3452.1				
05		Seal, dust 防尘圈 50×58×5/6.5	2		
06		Snap ring 挡圈 50×60×3	2		
07	075-	Snap ring 挡圈	2	GB/T894.1-1986	
-	-GB/T894.1				
08		Joint bearing 向心关节轴承	2		
09	0M6-JB/T7940.1	Oil cup 直通式压注油杯 M6	2	JB/T7940.1-95	
10		Snap ring 挡圈 $\phi 27 \times \phi 22 \times 4$	4		
11		Sealingring 活塞杆密封圈 80×64.5×6.3	1		
12		Support ring 支撑环	1		
13	0d43.7×3.55	O-ring 0 形圈 d43.7×3.55	1	GB/T3452.1-2005	
-	-GB/T3452.1				
14	0S $\phi 6$ -GB/T308	Steel ball 钢球 S $\phi 6$	24	GB/T308-1989	

# X I MAST 门架

## 1. HYDRAULIC SYSTEM MAST 门架管路系统 (基本型)

图 22		门架管路系统 (基本型)			HYDRAULIC SYSTEM MAST (NORMAL MAST KM)	
序号	图 号	零部件名称	件数	备 注	CPD30、CPD35	
Item No	Part No	Description	Q' ty	Remark		
01	CKM03-SH010	Oil cylinder 起升油缸总成	2	3-3.3 吨选用		
-	C2M3B-A0061	Oil cylinder 后升降油缸	2	3.5 吨选用		
02	CBM2A-16001	Hose H.P. 高压胶管	1			
03	C2M3A-01051	Oil return tee 回油三通	1			
04	019(内)×2.65-	O-ring O形圈 19(内)×2.65	1	GB3452.1-2000		
-	GB3452.1					
05	C2M1A-A0201	Flow regulator 限速阀	1			
06	CBM2A-18001	Hose H.P. 高压胶管	1			
07	0TBA-033	Tee joint 三通接头	1			
08	0TBA-001	Through joint M20- M22 直通接头	1			
09	0M12×1.25×25-	Bolt 螺栓 M12×1.25×25	2	GB/T5786-2000		
-	GB/T5786					
10	012-GB93	Washer 弹簧垫圈 12	2	GB93-87		
11	012-GB97.1	Washer 垫圈 12	2	GB/T97.1-2002		
12	0M8×16-GBT5783	Bolt 螺栓 M8×16	3	GB/T5783-2000		
13	08-GB93	Washer 弹簧垫圈 8	3	GB93-87		
14	CKM01-40001	Guard 护板	1			
15	C2M3A-A0191	Return pipe 门架回油管 II	1			
16	0d20-JB/T8870	Clamp 蜗轮蜗杆卡箍 Φ12-20	4	JB/T8870-97		
17	C2M3A-A0181	Return pipe 门架回油管 I	1			
18	C2M3A-01091	Tee fixed plate 三通固定板	1			

## 2. HYDRAULIC SYSTEM MAST 门架管路系统（二级全自由）

图 23		门架管路系统（二级全自由）			HYDRAULIC SYSTEM MAST (FULL FREE 2-STAGE MAST CZM)	
序号 Item No	图号 Part No	零部件名称 Description	件数 Q' ty	备注 Remark	CPD30、CPD35	
01	OTBA-107	RightAngleconnector M20-M27 直角接头				
-						
02	CKM03-SH010	Lifting oil cylinder 后升降油缸	2			
03	CBM3A-16001	Hose H.P. 高压胶管 II	1			
04	C2M3A-01051	Steel tube assembl 后缸钢管总成	1			
05		Rubber sheath 橡胶护套				
06		Pipe clamp 管夹				
07	OM8×16-GBT5783	Bolt 螺栓 M8×16	3	GB/T5783-2000		
08	08-GB93	Washer 弹簧垫圈 8	3	GB93-87		
09		Hose H.P. 门架供油高压胶管				
10	C2M1A-A0201	Flow regulator XSF-F16L-K 限速阀	1			
11	019(内)×2.65- GB/T3452.1	O-ring 0形圈 19(内)×2.65	1	GB/T3452.1-2000		
12	OTBA-001	Through joint M20-M22 直通接头	1			
13	OTBA-033	Tee joint 三通接头	1			
14	CKM01-40001	Guard 护板 II	1			
15	08-GB/T97.1	Washer 垫圈 8				
16	CBM3A-15001	Hose H.P. 高压胶管 I				
17	OM16×1.5×45- GB/T5786	Bolt 螺栓 M16×1.5×45	2	GB/T5786-2000		
18	016-GB93	Washer 弹簧垫圈 16	2	GB93-87		
19	016-GB/T97.1	Washer 垫圈 16	2	GB/T97.1-2002		
20	OM12×1.25×30- GB/T5786	Bolt 螺栓 M12×1.25×30	2	GB/T5786-2000		
21	012-GB93	Washer 弹簧垫圈 12	2	GB93-87		

图 23		门架管路系统（二级全自由）			HYDRAULIC SYSTEM MAST (FULL FREE 2-STAGE MAST CZM)	
序号	图 号	零部件名称	件数	备 注	CPD30、CPD35	
Item No	Part No	Description	Q' ty	Remark		
22	012-GB/t97.1	Washer 垫圈 12	2	GB/T97.1-2002		
23	0TBA-099	RightAngleconnector M27-M27 直角接头	1			
-						
24	CBM3A-A0061	Lifting oil cylinder 前升降油缸	1			

### 3. HYDRAULIC SYSTEM MAST 门架管路系统（三级全自由）

图 24	门架管路系统（三级全自由）				HYDRAULIC SYSTEM MAST (FULL FREE 3-STAGE MAST CSM)
序号 Item No	图 号 Part No	零部件名称 Description	件数 Q' ty	备 注 Remark	CPD30、CPD35
01	OM16×1.5×45- GB/T5786	Bolt 螺栓 M16×1.5×45	1	GB/T5786-2000	
-					
02	O16-GB/T97.1	Washer 垫圈 16	1	GB/T97.1-2002	
03	C2M3A-28031	The gasket 垫圈 I	1		
04	C2M3A-28021	Casing 套管	4		
05	CSM04-22501	Rubber roller 胶管滑轮	1		
06	CSM03-SH018	Hose H.P. 高压胶管III	1		
07	CSM04-30001	Return pipe 回油管 I	2		
08	0d20-JB/T8872	Clamp 蜗轮蜗杆卡箍 φ12-20	5	JB/T8872-2000	
09	C2M1A-A0201	Tee joint 三通接头	1		
10	CSM03-03402	Hose H.P. 高压胶管	1		
11	OTBA-031	RightAngleconnector M27-M22 直角接头	1		
-					
12	OTBA-044	Tee joint 凸三通接头	1		
13	OTBA-001	Through joint M20-M22 直通接头	1		
14	CSM03-05602	Steel tubeassembly 前缸钢管总成	1		
15	08-GB/T97.1	Washer 垫圈 8	4	GB/T97.1-2002	
16	OM8×25-GB/T5783	Bolt 螺栓 M8×25	4	GB/T5783-2000	
17	08-GB93	Washer 弹簧垫圈 8	4	GB93-87	
18	CSM03-05502	Hose H.P. 高压胶管IV	1		
19	CSM03-28702	Hose H.P. 高压胶管II	1		
20	OTBA-082	Connector M22-M22K 扣压直角接头	2		
21	C2M1A-A0201	Flow regulatorXSF-F16L-K 限速阀	1		
22	CSM03-03202	The three way a' y 三通安装总成	1		
23	CSM09-25041	Hosclamp 管卡	1		

#### 4. MAST 门架（基本型）

图 25		门架（基本型）			MAST (NORMAL MAST KM)	
序号	图 号	零部件名称	件数	备 注	CPD30、CPD35	
Item No	Part No	Description	Q' ty	Remark		
01	CKM21-SH019	Outer mast 外门架总成	1	3-3.3 吨选用		
-	CKM21-SH053	Outer mast 外门架总成	1	3.5 吨选用		
02	C2M3A-02011	Slipper 限位滑块	2			
03	C2M3A-A7031	Shim 调整垫片	2			
04	C2M3A-04001	Roller 180708 滚轮	2			
05	040-GB/T894.1	Snap ring 轴用弹性挡圈 40	2	GB/T894.1-86		
06	C2M3A-02041	Shim 调整垫块 I	8			
07	C2M3A-A7041	Shim 调整垫片 II	8			
08	C2M3A-05001	Sideroller 84904A 侧滚轮	2			
09	010-GB93	Washer 弹性垫圈 10	10	GB93-87		
10	010×1.25×45	Bolt 螺栓 M10×1.25×45	8	GB/T5786-2000		
-	-GB/T5786					
11	C2M3A-41001	Pin 倾斜缸销轴	2			
12	010×1.25×20	Bolt 螺栓 M10×1.25×20	2	GB/T5786-2000		
-	-GB/T5786					
13	OM10 ×1-	Fitting 直通式润滑脂嘴 M10×1	2	ZB/T33001.2		
-	ZB/T33001.2					
14	C2M3A-01011	Bushing 门架轴衬	2			
15	C2M3A-01021	Cap 支座盖	2			
16	016×1.5×70	Bolt 螺栓 M16×1.5×70	4	GB/T5786-2000		
-	-GB/T5786					
17	016-GB93	Washer 弹性垫圈 16	4	GB93-87		
18	C2M3A-A0191	Roller 980811NT 滚轮	2			
19	055-GB/T894.1	Snap ring 轴用弹性挡圈 55	2	GB/T894.1-86		
20	CKM21-SH016	Inner mast 内门架总成	1	3-3.3 吨选用		
-	CKM21-SH054	Inner mast 内门架总成	1	3.5 吨选用		

## 5. MAST 门架（二级全自由）

图 26	门架（二级全自由）				MAST (FULL FREE 2-STAGE MAST CZM)
序号	图 号	零部件名称	件数	备 注	CPD30、CPD35
Item No	Part No	Description	Q' ty	Remark	
01	CBM3B-A0021	Outer mast 外门架总成	1		
02	C2M3A-02011	Slipper 限位滑块	2		
03	C2M3A-A7031	Shim 调整垫片	2		
04	C2M3A-04001	Roller 180708 滚轮	2		
05	040-GB894.1	Snap ring 轴用弹性挡圈 40	2	GB/T894.1-86	
06	C2M3A-02041	Shim 调整垫块 I	8		
07	C2M3A-A7041	Shim 调整垫片 II	8		
08	C2M3A-05001	Side roller 84904A 侧滚轮	2		
09	010-GB93	Washer 弹性垫圈 10	10	GB93-87	
10	0M10×1.25×45-GB/T5786	Bolt 螺栓 M10×1.25×45	8	GB/T5786-2000	
11	CKM01-03601	Pin 倾斜缸销轴	2		
12	0M10×1.25×20-GBT5786	Bolt 螺栓 M10×1.25×20	2	GB/T5786-2000	
13	0M10x1-ZB/T33001.2	Fitting 直通式润滑脂嘴 M10×1	2	ZB/T33001.2	
14	C2M3A-01011	Bushing 门架轴衬	2		
15	C2M3A-01021	Cap 支座盖	2		
16	0M16×1.5×70-GB/T5786	Bolt 螺栓 M16×1.5×70	4	GB/T5786-2000	
17	016-GB93	Washer 弹性垫圈 16	4	GB93-87	
18	C2M3A-A0191	Roller 980811NT 滚轮	2		
19	055-GB/T894.1	Snap ring 轴用弹性挡圈 55	2	GB/T894.1-86	
20	CBM3A-A0031	Inner mast 内门架总成	1		

## 6. MAST 门架（三级全自由）

图 27	门架（三级全自由）				MAST (FULL FREE 3-STAGE MAST CSM)
序号	图 号	零部件名称	件数	备 注	CPD30、CPD35
Item No	Part No	Description	Q' ty	Remark	
01	CBM3B-A0021	Outer mast 外门架总成	1		
02	C2M3A-02011	Slipper 限位滑块	2		
03	C2M3A-A7031	Shim 调整垫片 I	2		
04	C2M3A-04001	Roller 180708 滚轮	2		
05	040-GB/T894.1	Snap ring 轴用弹性挡圈 40	2	GB/T894.1-86	
06	C2M3A-02041	Shim 调整垫块 I	8		
07	C2M3A-A7041	Shim 调整垫片 II	8		
08	C2M3A-05001	Side roller 84904A 侧滚轮	2		
09	010-GB93	Washer 弹性垫圈 10	10	GB93-87	
10	0M10×1.25×45-GB/T5786	Bolt 螺栓 M10×1.25×45	8	GB/T5786-2000	
11	CKM01-03601	Pin 倾斜缸销轴	2		
12	0M10×1.25×20-GB/T5786	Bolt 螺栓 M10×1.25×20	2	GB/T5786-2000	
13	0M10x1-ZB/T33001.2	Fitting 直通式润滑脂嘴 M10×1	2	ZB/T33001.2	
14	C2M3A-01011	Bushing 门架轴衬	2		
15	C2M3A-01021	Cap 支座盖	2		
16	0M16×1.5×70-GB/T5786	Bolt 螺栓 M16×1.5×70	4	GB/T5786-2000	
17	016-GB93	Washer 弹性垫圈 16	4	GB93-87	
18	C2M3A-A0191	Roller 980811NT 滚轮	2		
19	055-GB/T894.1	Snap ring 轴用弹性挡圈 55	2	GB/T894.1-86	
20	CBM3A-A0031	Inner mast 内门架总成	1		
21	C2M3A-12001	Sprocker 780708K 链轮	2		
22	CCM3A-A0031	Inner mast 中门架总成	1		

## 7. FORK&LIFT BRACKET 货叉及货叉架（基本型）

图 28	货叉及货叉架（基本型）				FORK&LIFT BRACKET (NORMAL MAST KM)
序号	图 号	零部件名称	件数	备 注	CPD30、CPD35
Item No	Part No	Description	Q' ty	Remark	
01	C2M3A-A0201	Pallet fork 货叉总成	2		
02	C2M3A-26001	Block shelf assembly 挡货架总成	1		
03	014-GB93	Washer 垫圈 14	4	GB93-87	
04	0M14×25-GBT5782	Bolt 螺栓 M14×25	2	GB/T5782-2000	
05	0M14×30-GBT5782	Bolt 螺栓 M14×30	2	GB/T5782-2000	
06	CKM21-03101	Lift bracket 3-3.5T 货叉架总成	1	3-3.5 吨选用	
-	CKM21-11001	Lift bracket 3-3.5t 货叉架总成		3.5 吨选用	
07	C2M3A-17041	Shim 调整垫块	4		
08	C2M3A-A7041	Shim 调整垫片 II	4		
09	C2M3A-22001	Shaft side roller C2-3 侧滚轮	2		
10	012-GB93	Washer 弹性垫	2	GB93-87	
11	0M12×1.25×45-GBT5786	Bolt 螺栓 M12×1.25×45	2	GB/T5786-2000	
12	055-GB894.1	Snap ring 轴用弹性挡圈 55	6	GB894.1-86	
13	C2M3A-17011	Shield 760311NT 防尘圈	4		
14	C2M3A-21001	Side roller 760311NT 侧滚轮组	4		
15	C2M3A-A0191	Roller 980811NT 滚轮	6		
16	C2M3A-17031	Seal 760311NT 防松片	4		
17	C2M3A-17021	Adjust 760311NT 调节螺钉	4		

## 8. FORK&LIFT BRACKET 货叉及货叉架（二级全自由）

图 29	货叉及货叉架（二级全自由）				FORK&LIFT BRACKET（FULL FREE 2-STAGE MAST CZM）
序号	图 号	零部件名称	件数	备 注	CPD30、CPD35
Item No	Part No	Description	Q' ty	Remark	
01	C2M3A-A0201	Pallet fork 货叉总成	2		
02	C2M3A-26001	Block shelf assembly 挡货架总成	1		
03	014-GB93	Washer 垫圈 14	4	GB93-87	
04	0M14×25-GBT5782	Bolt 螺栓 M14×25	2	GB/T5782-2000	
05	0M14×30-GBT5782	Bolt 螺栓 M14×30	2	GB/T5782-2000	
06	CBM3A-10001	Lift bracket 3 吨货叉架总成	1		
07	C2M3A-17041	Shim 调整垫块	4		
08	C2M3A-A7041	Shim 调整垫片 II	4		
09	C2M3A-22001	Shaft side roller C2-3 侧滚轮	2		
10	012-GB93	Washer 弹性垫圈 12	2	GB93-87	
11	0M12×1.25×45-GB/T5786	Bolt 螺栓 M12×1.25×45	2	GB/T5786-2000	
12	055-GB/T894.1	Snap ring 轴用弹性挡圈 55	6	GB/T894.1-86	
13	C2M3A-17011	Shield 760311NT 防尘圈	4		
14	C2M3A-21001	Side roller 760311NT 侧滚轮组	4		
15	C2M3A-A0191	Roller 980811NT 滚轮	6		
16	C2M3A-17031	Seal 760311NT 防松片	4		
17	C2M3A-17021	Adjust 760311NT 调节螺钉	4		

## 9. FORK&LIFT BRACKET 货叉及货叉架（三级全自由）

图 30	货叉及货叉架（三级全自由）				FORK&LIFT BRACKET（FULL FREE 3-STAGE MAST CSM）
序号	图 号	零部件名称	件数	备 注	CPD30、CPD35
Item No	Part No	Description	Q' ty	Remark	
01	C2M3A-A0201	Pallet fork 货叉总成	2		
02	C2M3A-26001	Block shelf assembly 挡货架总成	1		
03	014-GB93	Washer 垫圈 14	4	GB93-87	
04	0M14×25-GBT5782	Bolt 螺栓 M14×25	2	GB/T5782-2000	
05	0M14×30-GBT5782	Bolt 螺栓 M14×30	2	GB/T5782-2000	
06	CCM3A-20001	Lift bracket 货叉架总成	1		
07	C2M3A-17041	Shim 调整垫块	4		
08	C2M3A-A7041	Shim 调整垫片 II	4		
09	C2M3A-22001	Shaft side roller C2-3 侧滚轮	2		
10	012-GB93	Washer 弹性垫圈 12	2	GB93-87	
11	0M12×1.25×45-GB/T5786	Bolt 螺栓 M12×1.25×45	2	GB/T5786-2000	
12	055-GB/T894.1	Snap ring 轴用弹性挡圈 55	6	GB/T894.1-86	
13	C2M3A-17011	Shield 760311NT 防尘圈	4		
14	C2M3A-21001	Side roller 760311NT 侧滚轮组	4		
15	C2M3A-A0191	Roller 980811NT 滚轮	6		
16	C2M3A-17031	Seal 760311NT 防松片	4		
17	C2M3A-17021	Adjust 760311NT 调节螺钉	4		



## 11. REAR LIFT CYLINDER 后起升缸 (二级全自由)

图 32		后起升缸 (二级全自由)			REAR LIFT CYLINDER (FULL FREE 2-STAGE MAST CZM)	
序号	图 号	零部件名称	件数	备 注	CPD30、CPD35	
Item No	Part No	Description	Q' ty	Remark		
01	0M20x1.5x45	Bolt 螺栓 M20×1.5×45	2	GB/T5786-2000		
02	020-GB93	Washer 弹性垫圈 20	2	GB93-87		
03	CBM2A-A7011	Cylinder headblock 缸头座 (左)	1			
04		Cylinder rod head 左缸杆头	1			
05		Cap cylinder 缸盖	2			
06		Dust ring 防尘圈 40	2			
07		Packing 密封圈 40×50×6	2			
08		Snap ring 挡圈 50×40×3	2			
09		Bushing 钢背轴承 4045	2			
10		Cap 导向套	2			
11		Piston rod ass'y 左柱塞杆总成	1			
12		Sleeve 调整套	2			
13		Cylinder 缸筒	2			
14		O-ring O 形圈 21×2.4	2	GB3452.1		
15		Pin 销 D10×26	2			
16	CBM2A-A7011	Cylinder headblock 缸头座 (右)	1			
17		Cylinder rod head 右缸杆头	1			
18		Piston rod ass'y 右柱塞杆总成	1			
19	C2M2A-18001	U-bolt U 型螺栓	2			
20	C2M1A-01041	Spacer 橡胶垫	2			
21	C2M3A-45001	Support 油缸支撑块	2			
22	0M10×1.25-GB/T6171	Nut 螺母 M10×1.25	4	GB/T6171-2000		
23	010-GB93	Washer 弹性垫圈 10	4	GB93-87		
24	010-GB/T96.1	Washer 大平垫 10	4	GB/T96.1-2000		
25	0M12×1.25-GB/T6171	Nut 螺母 M12×1.25	2	GB/T6171-2000		
26	0M12×1.25×45-	Bolt 螺栓 M12×1.25×45	2	GB/T5786-2000		









# 15. LIFT CYLINDER 倾斜油缸

图 36		倾斜油缸			TILT CYLINDER	
序号	图 号	零部件名称	件数	备 注	CPD30、CPD35	
Item No	Part No	Description	Q' ty	Remark		
01		Snap ring 挡圈 47	2			
02		Bushing 关节轴承	2			
03		Ear ring 耳环	2			
04		Fitting grease 直通式滑脂嘴 Z1/8	2			
05	OM14×1.5-	Nut 螺母 M14×1.5	2	GB/T6171-2000		
-	GB/T6171					
06	014-GB93	Washer 垫圈 14	2	GB93-87		
07		Snap washer 垫子	2			
08		Cylinder head 缸盖	2			
09	073×2.65-	O-ring 0型密封圈 73×2.65	2	GB/T3452.1-2005		
-	GB/T3452.1					
10	070×65×1.25	Snap ring 挡圈 70×65×1.25	2	GB/T1235-76		
-	GB/T1235					
11	070×3.1-GB/T1235	O-ring 0型密封圈 70×3.1	2	GB/T1235-76		
-						
12		Seal, dust 防尘圈 32×40×5/6.5	2			
13		Bushing 轴套 30×34×32	2			
14	032×42×2	Snap ring 挡圈 32×42×2	2			
-	GB1235					
15		Sealing ring 活塞杆密封圈 32×42×7.3	2			
-						
16	OM14×1.5×55	Bolt 螺栓 M14×1.5×55	2	GB/T5782-2000		
-	GB/T5782					
17		Spacer 调整轴套	2			
18		Body piston ass'y 活塞体	2			



## X II SIGNAGE 标识标贴

图 37		标识标牌			SIGNAGE
序号	图 号	零部件名称	件数	备 注	CPD30、CPD35
Item No	Part No	Description	Q' ty	Remark	
1	Sign0-06901	Lifting logo 起吊标识 (英文)	4		
2	Sign0-01601	The left door frame safety signs			
-		门架安全左侧标牌 (英文)	1		
3	Sign2-02001	DC fork J series logo			
4		直流电叉J系列标识	2	左右各一	
-	Sign2-01801	AC fork J series logo			
-		交流电叉J系列标识	2	左右各一	
6	Sign0-06301	No climbing safety signs			
-		禁攀安全标牌 (英文)	1		
7	Sign0-06201	Safety signs			
-		横梁安全标牌 (英文)	1		
8	Sign0-06701	The door frame on the right side			
-		Of safety sign			
-		门架安全右侧标牌 (英文)	1		
9	Sign2-03801	Electric fork lubrication			
-		chart sign			
-		电叉润滑系统图标牌 (英文)	1		
10	Sign2-01001	Battery forklift trucks			
-		nameplate			
-		蓄电池平衡重式叉车铭牌	1		
-		(国际中性)			
11	Sign2-03901	Brake fluit signs			
-		制动液标牌 (英文)	1		
13	Sign0-08801	OPS 警示标识 (英文)	1		
14	Sign0-04701	The total power switch logo			
-		总断电开关标识 (英文)	1		

图 37 标识标牌					SIGNAGE
序号	图 号	零部件名称	件数	备 注	CPD30、CPD35
Item No	Part No	Description	Q' ty	Remark	
15	Sign0-04601	Check bolt fixed signs			
-		螺栓检查固定标识 (英文)	1		
16	Sign0-06401	Forklift driving before the inspection otice signs			
-		开车前检查项目标牌 (英文)	1		
17	Sign2-04601	Battery forklift Precautions signage			
-		蓄电池叉车使用注意事项标牌 (英文)	1		
18	Sign0-05001	3t load curve signs			
-		3t 负载曲线标牌 (英文)	1	3t 电叉选用	
-	Sign0-05101	3.5t load curve signs			
-		3.5t 负载曲线标牌 (英文)	1	3.5t 电叉选用	
19	Sign0-07001	The instructions on the label			
-		使用须知标牌 (英文)	1		
20	Sign2-04001	Overspeed alarm system			
-		超速报警系统标牌 (英文)	1	超速报警系统选	
21	Sign2-04101	Overload alarm system signs			
-		超载报警系统标牌 (英文)	1	超载报警系统选	
22	Sign0-07301	Hydraulic oil label			
-		液压油标牌 (英文)	1		
23	Sign0-07601	Fork installation instructions			
-		货叉安装指示标牌 (英文)	1		
24	Sign0-03601	3t electrick forklift			
-		tire pressure lable			
-		3t 电叉轮胎气压标牌 (英文)	1		

