

第五部分 操纵系统目录

Part V Control system contents

(A) CPCD10/15/18-XW32F (B) CPCD10/15/18-XW32B (C) CPCD10/15/18-XW32M (D) CPYD15/18-XW21F (D1) CPYD15/18-XW51F
 (E) CPYD15/18-XW21B (E1) CPYD15/18-XW51B (F) CPYD15/18-XW21M (F1) CPYD15/18-XW51M (G) CPCD10/15/18-XW12F
 (H) CPCD10/15/18-XW10F (I) CPQD10/15/18-XW21F

序号 Item	名称 Description	适用车型 Serial No.	页码 Page
图 1 Fig.1	制动与微动操纵 (一) Brake and inching control (I)	(A) (B) (C) (D) (D1) (E) (E1) (F) (F1) (G) (H) (I)	5-1
图 2 Fig.2	制动与微动操纵 (二) Brake and inching control (II)	(B) (E) (E1)	5-4
图 3 Fig.3	制动与微动操纵 (三) Brake and inching control (III)	(C) (F) (F1)	5-5
图 4 Fig.4	油门操纵总成 Throttle control assy	(A) (B) (C) (G) (H)	5-6
图 5 Fig.5	油门操纵总成 Throttle control assy	(D) (E) (E1) (F) (F1) (I)	5-9
图 6 Fig.6	驻车制动器总成 Handle control	(A) (B) (D) (D1) (E) (E1) (G) (H) (I)	5-11
图 7 Fig.7	驻车制动器总成 Handle control	(C) (F) (F1)	5-12
图 8 Fig.8	管路总成 Brake pipe assy	(A) (B) (D) (D1) (E) (E1) (G) (H) (I)	5-13
图 9 Fig.9	管路总成 Brake pipe assy	(C) (F) (F1)	5-14
图 10 Fig.10	制动总泵 Brake pump	(A) (B) (D) (D1) (E) (E1) (G) (H) (I)	5-16
图 11 Fig.11	制动总泵 Brake pump	(C) (F) (F1)	5-18

图1 制动与微动操纵（一）

Fig.1 Brake and inching control (I)

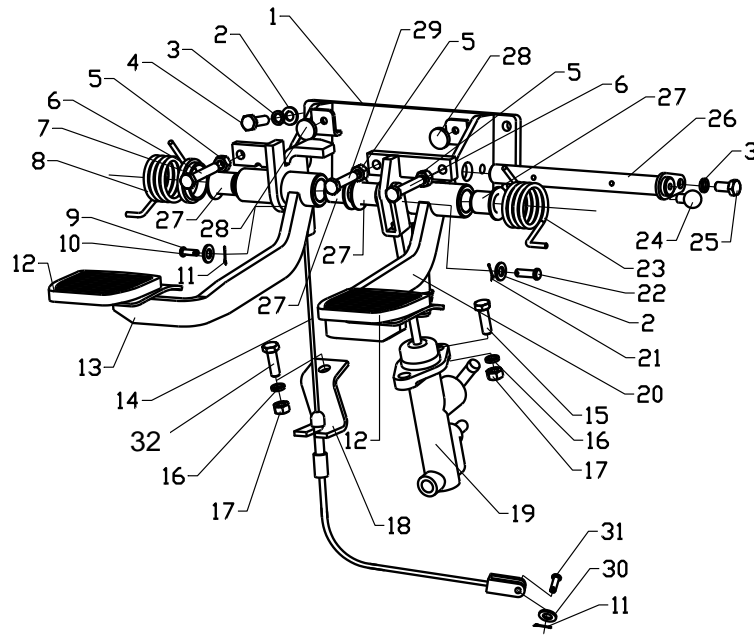

序号 Item	物料码 Part No.	名称 Description	数量 Qty	备注或适用车型 Remarks Or Serial No.
1	XF250-511000-000	制动微动支架 Brake pedal support	1	
2	G0097P1-000008-00	垫圈 8 Washer 8	5	
3	G000093-000008-00	垫圈 8 Washer 8	6	Ⓒ Ⓕ Ⓕ ₁
3	G000093-000008-00	垫圈 8 Washer 8	5	Ⓐ Ⓑ Ⓓ Ⓓ ₁ Ⓔ Ⓔ ₁ Ⓖ Ⓕ Ⓖ
4	G005783-008025-00	螺栓 M8×25 Bolt M8×25	5	
5	G006170-000008-00	螺母 M8 Nut M8	3	
6	G005783-008045-00	螺栓 M8×45 Bolt M8×45	2	
7	XF250-510002-000	隔套 Sleeve	1	
8	XF250-510003-000	微动扭簧 Inching spring	1	
9	G000882-006020-01	销轴 B6×20 Pin shaft B6×20	1	
10	G0097P1-000006-00	垫圈 6 Washer 6	1	
11	G000091-002012-00	销 2×12 Pin 2×12	2	Ⓐ Ⓑ Ⓓ Ⓓ ₁ Ⓔ Ⓔ ₁ Ⓖ Ⓕ Ⓖ
11	G000091-002012-00	销 2×12 Pin 2×12	1	Ⓒ Ⓕ Ⓕ ₁
11	G000091-3P2016-00	销 3.2×16 Pin 3.2×16	1	Ⓒ Ⓕ Ⓕ ₁ 拉线下端 Wire bottom
12	XF250-512002-000	踏板垫 Pedal gasket	2	

图1 制动与微动操纵 (一)

Fig.1 Brake and inching control (I)

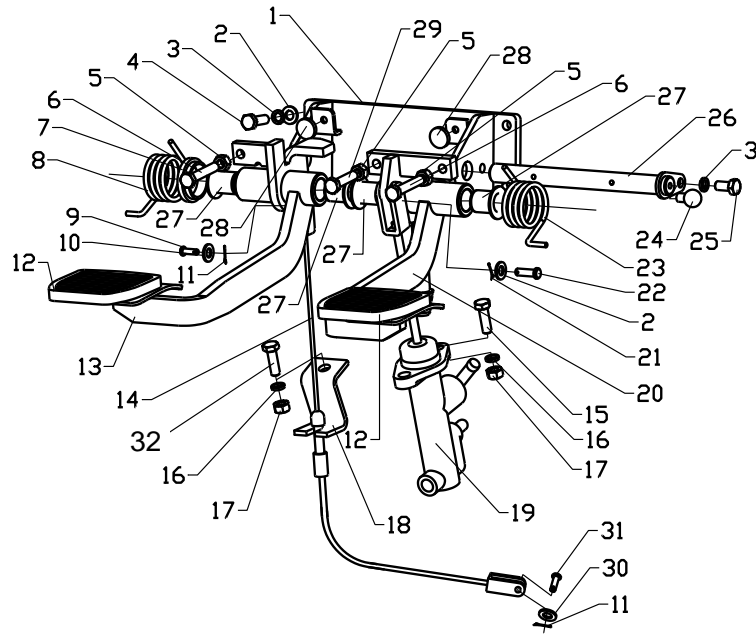

序号 Item	物料码 Part No.	名称 Description	数量 Qty	备注或适用车型 Remarks Or Serial No.
13	XF250-512100-000	微动踏板 Inching pedal	1	
14	XF250-510100-000	微动拉线总成 Inching line assy	1	Ⓐ Ⓓ Ⓣ ⓖ ⓗ ⓘ
14	XB250-510100-000	微动拉线总成 Inching line assy	1	Ⓑ Ⓔ Ⓔ1
14	XM250-510100-000	微动拉线总成 Inching line assy	1	Ⓒ Ⓕ Ⓕ1
15	G005783-010030-00	螺栓 M10×30 Bolt	3	
16	G000093-000010-00	垫圈 10 Washer 10	3	
17	G006170-000010-00	螺母 M10 Nut M10	3	
18	XF250-510200-000	微动拉线支架 Inching line support	1	
19	XF150-511000-000	制动总泵 Brake pump	1	Ⓐ Ⓑ Ⓓ Ⓣ Ⓔ Ⓔ1 ⓖ ⓗ ⓘ
19	XM250-512000-000	制动总泵 Brake pump		Ⓒ Ⓕ Ⓕ1
20	XF250-513100-000	制动踏板 Brake pedal	1	Ⓐ Ⓑ Ⓓ Ⓣ Ⓔ Ⓔ1 ⓖ ⓗ ⓘ
20	XM250-513100-000	制动踏板 Brake pedal	1	Ⓒ Ⓕ Ⓕ1
21	G000091-3P2014-00	销 3.2×14 Pin 3.2×14	1	
22	G000882-008026-01	销轴 B8×26 Pin shaft B8×26	1	
23	XF250-510004-000	制动扭簧 Brake spring	1	

图1 制动与微动操纵（一）

Fig.1 Brake and inching control (I)

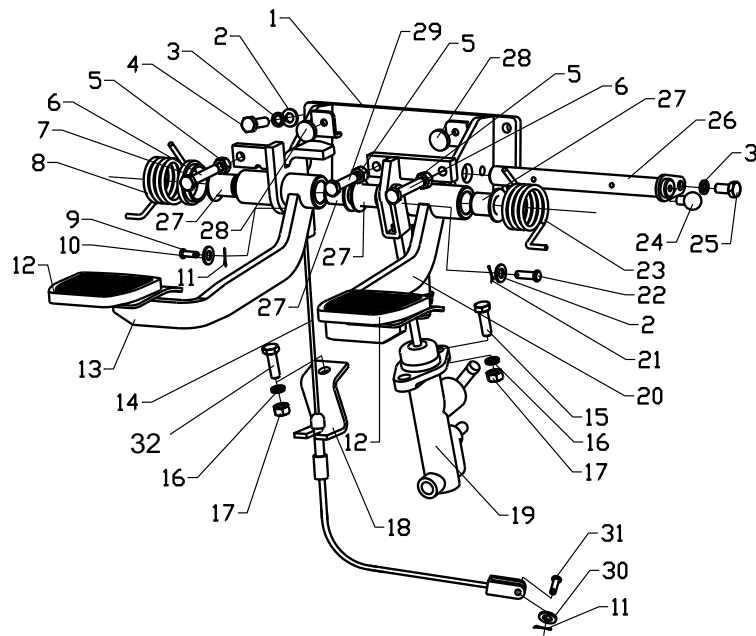

序号 Item	物料码 Part No.	名称 Description	数量 Qty	备注或适用车型 Remarks Or Serial No.
24	Q701B90-NPT1/16-G00	油杯 Oil grease	1	
25	G005783-008012-00	螺栓 M8×12 Bolt M8×12	1	
26	XF250-514000-000	销轴 Shaft	1	
27	XF250-512001-000	衬套 Bushing	4	
28	XF250-510001-000	止推圈 Thrust collars	2	
29	G005783-008035-00	螺栓 M8×35 Bolt M8×35	1	
30	G0097P1-000005-00	垫圈 5 Washer 5	1	
31	G000882-005016-01	销轴 B5×16 Pin shaft B5×16	1	(A) (B) (D) (D1) (E) (E1) (G) (H) (I)
31	G000882-008018-00	销轴 B8×18 Pin shaft B8×18	1	(C) (F) (F1)
32	G005783-010025-00	螺栓 M10×25 Bolt M10×25	1	

图2 制动与微动操纵 (二)
Fig.2 Brake and inching control (II)

ⓑ CPCD10/15/18-XW32B ⓔ CPCD15/18-XW21B ⓔ① CPCD15/18-XW51B

序号 Item	物料码 Part No.	名称 Description	数量 Qty	备注或适用车型 Remarks Or Serial No.
1	G005782-008065-00	螺栓 M8×65 Bolt M8×65	2	
2	G000093-000008-00	垫圈 8 Washer 8	2	
3	XB150-516200-000	底板总成 Fixing bracket	1	
4	R561-513002-G00	复合衬套 0806 Bearing 0806	2	SF-1-0806-F-G00
5	XB150-516100-000	销轴总成 Shaft assy	1	
6	G000879-003020-00	销 3×20 Pin 3×20	1	
7	R561-513001-000	下板 Plate	1	
8	R450-510003-000	弹簧 Spring	1	



图3 制动与微动操纵（三）

Fig.3 Brake and inching control (III)

©CPCD10/15/18-XW32M ⑤CPYD15/18-XW21M ⑥CPYD15/18-XW51M

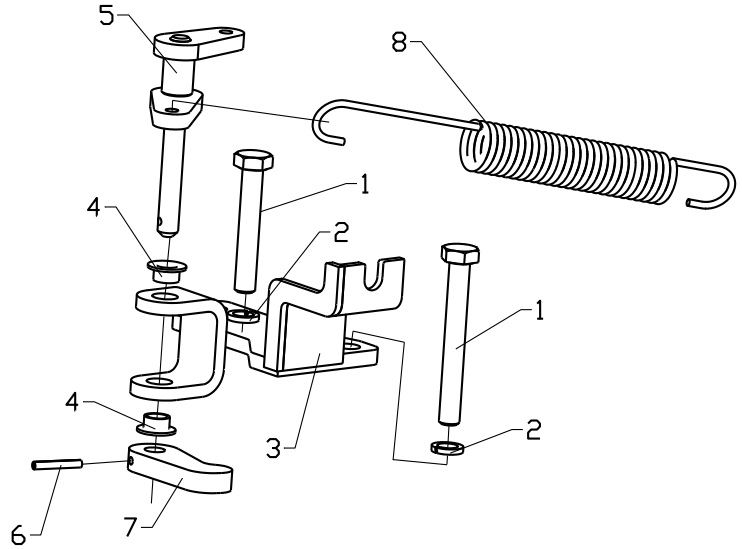
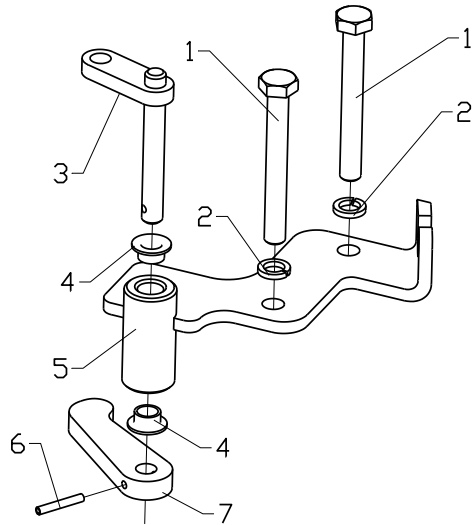

序号 Item	物料码 Part No.	名称 Description	数量 Qty	备注或适用车型 Remarks Or Serial No.
1	G005782-008065-00	螺栓 M8×65 Bolt M8×65	2	
2	G000093-000008-00	垫圈 8 Washer 8	2	
3	XM250-511100-000	销轴总成 Shaft assy	1	
4	R561-513002-G00	复合衬套 0806 Bearing	2	SF-1-0806-F-G00
5	XM250-511200-000	轴套总成 Shaft sleeve assy	1	
6	G000879-003020-00	销 3×20 Pin 3×20	1	
7	XM250-511001-000	下板 Plate	1	

图4 油门操纵总成
Fig.4 Throttle control assy

Ⓐ CPCD10/15/18-XW32F Ⓑ CPCD10/15/18-XW32B Ⓒ CPCD10/15/18-XW32M
Ⓓ CPCD10/15/18-XW12F Ⓔ CPCD10/15/18-XW10F

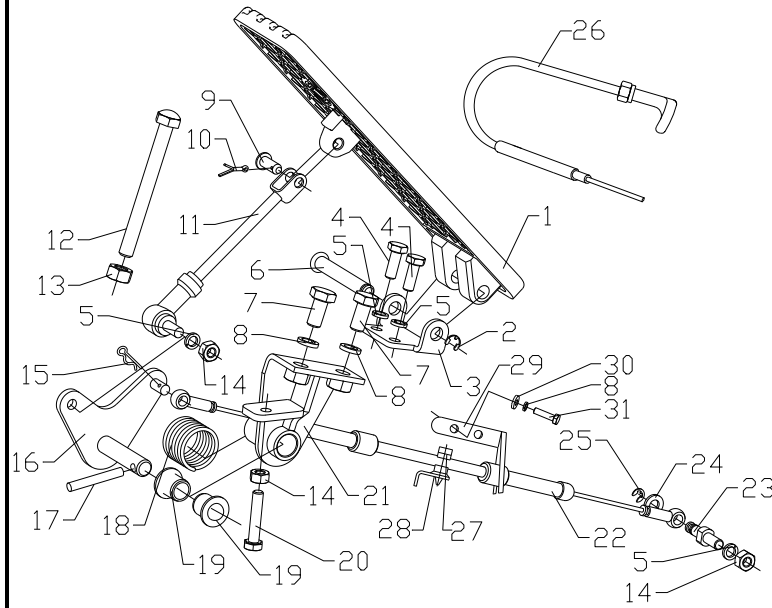

序号 Item	物料码 Part No.	名称 Description	数量 Qty	备注或适用车型 Remarks Or Serial No.
1	XF250-520001-000	油门踏板 Throttle pedal	1	
2	G000896-000006-00	挡圈 6 Snap ring 6	1	
3	XF250-520005-000	支架 Support	1	
4	G005783-006016-00	螺栓 M6×16 Bolt M6×16	2	
5	G000093-000006-00	垫圈 6 Washer 6	4	
6	XF250-520002-000	销轴 Shaft	1	
7	G005783-008016-00	螺栓 M8×16 Bolt M8×16	2	
8	G000093-000008-00	垫圈 8 Washer 8	2	
9	G000882-006016-01	销轴 B6×16 Pin shaft B6×16	1	
10	G000091-002012-00	销 2×12 Pin 2×12	1	
11	XF250-521000-000	连杆 Rod	1	
12	15PH-500001	限位螺栓 Thrust bolt	1	
13	G006170-000008-00	螺母 M8 Nut M8	1	
14	G006170-000006-00	螺母 M6 Nut M6	3	
15	XF250-520006-G00	锁销 6 Pin 6	1	

图4 油门操纵总成
Fig.4 Throttle control assy

Ⓐ CPCD10/15/18-XW32F Ⓑ CPCD10/15/18-XW32B Ⓒ CPCD10/15/18-XW32M
Ⓓ CPCD10/15/18-XW12F Ⓔ CPCD10/15/18-XW10F

序号 Item	物料码 Part No.	名称 Description	数量 Qty	备注或适用车型 Remarks Or Serial No.
16	XF250-524000-000	摇臂 Rod arm	1	
17	G000879-005040-00	销 5×40 Pin 5×40	1	
18	XF250-520004-000	扭簧 Spring	1	
19	XF250-520003-000	衬套 Bushing	2	
20	G005783-006030-00	螺栓 M6×30 Bolt M6×30	1	
21	XF250-522000-000	支架 Support	1	
22	XF250-523000-000	油门拉线 Throttle line	1	Ⓐ Ⓑ Ⓒ
22	XF155-521000-000	油门拉线 Throttle line	1	Ⓓ
22	XF308-521000-000	油门拉线 Throttle line	1	Ⓔ
23	GR501-520001-000	拉线挂销 Pin	1	Ⓐ Ⓑ Ⓒ Ⓓ
23	N121-510001-000	拉线挂销 Pin	1	Ⓔ
24	G0097P1-000006-00	垫圈 6 Washer 6	1	
25	G000896-000004-00	挡圈 4 Snap ring 4	1	
26	N150-522000-000	手风门推杆总成 Thrust rod assembly	1	Ⓓ
27	XF250-520008-000	管夹 Clip	1	



图4 油门操纵总成
Fig.4 Throttle control assy

Ⓐ CPCD10/15/18-XW32F Ⓑ CPCD10/15/18-XW32B Ⓒ CPCD10/15/18-XW32M
Ⓓ CPCD10/15/18-XW12F Ⓔ CPCD10/15/18-XW10F

序号 Item	物料码 Part No.	名称 Description	数量 Qty	备注或适用车型 Remarks Or Serial No.
28	XF250-520007-000	管夹安装板 Clip mounting plate	1	
29	R968-510001-000	支架 Support	1	
30	G0097P1-000008-00	垫圈 8 Washer 8	2	
31	G005783-008020-00	螺栓 M8×20 Bolt M8×20	2	

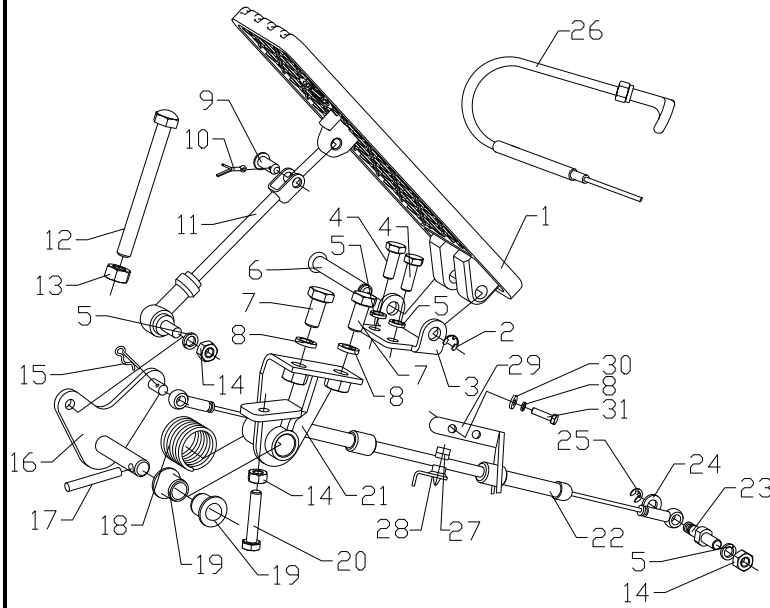

图5 油门操纵总成
Fig.5 Throttle control assy

Ⓓ CPYD15/18-XW21F Ⓔ CPYD15/18-XW51F Ⓔ CPYD15/18-XW21B Ⓔ CPYD15/18-XW51B
Ⓕ CPYD15/18-XW21M Ⓕ CPYD15/18-XW51M Ⓕ CPYD15/18-XW21F

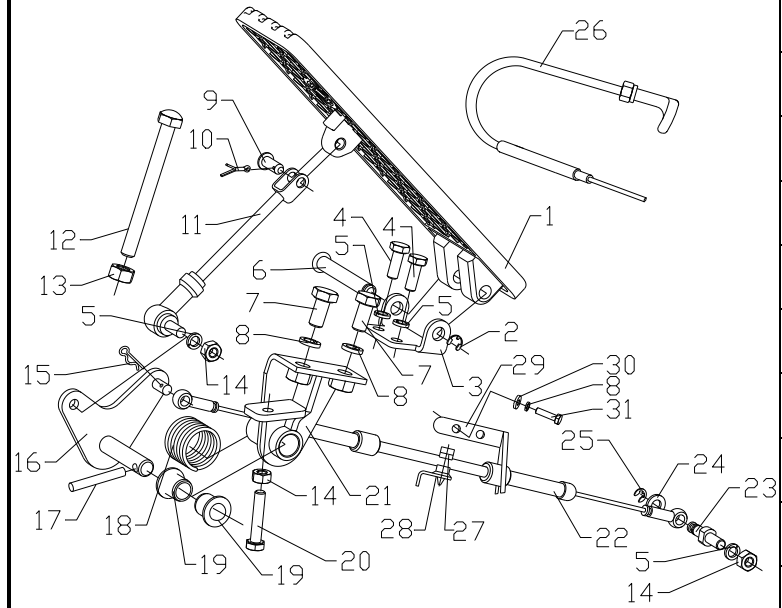
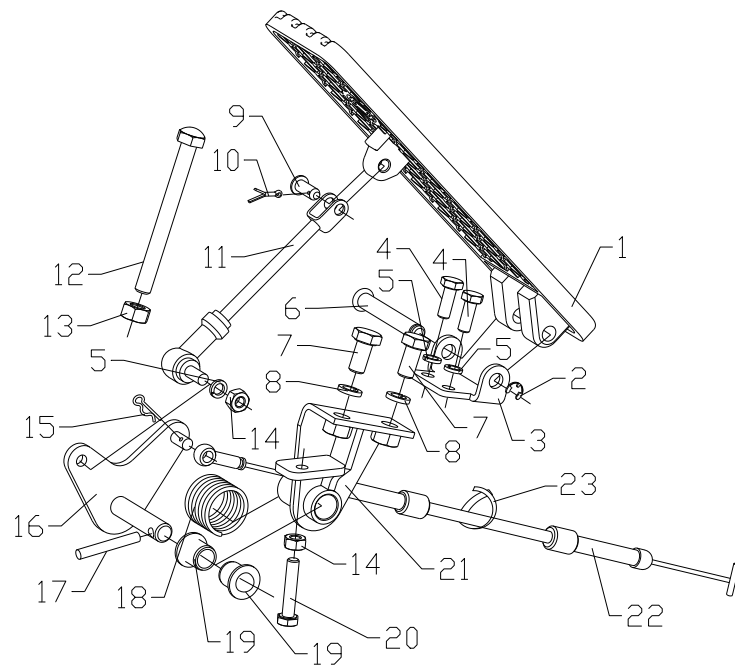

序号 Item	物料码 Part No.	名称 Description	数量 Qty	备注或适用车型 Remarks Or Serial No.
1	XF250-520001-000	油门踏板 Throttle pedal	1	
2	G000896-000006-00	挡圈 6 Snap ring 6	1	
3	XF250-520005-000	支架 Support	1	
4	G005783-006016-00	螺栓 M6×16 Bolt M6×16	2	
5	G000093-000006-00	垫圈 6 Washer 6	4	
6	XF250-520002-000	销轴 Shaft	1	
7	G005783-008016-00	螺栓 M8×16 Bolt M8×16	2	
8	G000093-000008-00	垫圈 8 Washer 8	2	
9	G000882-006016-00	销轴 6×16 Pin shaft 6×16	1	
10	G000091-002012-00	销 2×12 Pin 2×12	1	
11	XF250-521000-000	连杆 Rod	1	
12	15PH-500001	限位螺栓 Thrust bolt	1	
13	G006170-000008-00	螺母 M8 Nut M8	1	
14	G006170-000006-00	螺母 M6 Nut M6	3	
15	XF250-520006-G00	锁销 6 Pin 6	1	

图5 油门操纵总成
Fig.5 Throttle control assy

Ⓐ CPYD15/18-XW21F Ⓑ CPYD15/18-XW51F Ⓒ CPYD15/18-XW21B Ⓓ CPCD15/18-XW51B
Ⓔ CPYD15/18-XW21M Ⓕ CPYD15/18-XW51M Ⓖ CPQD10/15/18-XW21F

序号 Item	物料码 Part No.	名称 Description	数量 Qty	备注或适用车型 Remarks Or Serial No.			
							
16	XF250-524000-000				摇臂 Rod arm	1	
17	G000879-005040-00				销 5×40 Pin 5×40	1	
18	XF250-520004-000				扭簧 Spring	1	
19	XF250-520003-000				衬套 Bushing	2	
20	G005783-006030-00				螺栓 M6×30 Bolt M6×30	1	
21	XF250-522000-000				支架 Support	1	
22	XF251-523000-000				油门拉线 Throttle line	1	
23	PKD-170-G00				捆线带 Tie line	1	

图6 驻车制动器总成
Fig.6 Handle control

Ⓐ CPCD10/15/18-XW32F Ⓑ CPCD10/15/18-XW32B Ⓓ CPYD15/18-XW21F Ⓣ CPYD15/18-XW51F
Ⓔ CPYD15/18-XW21B ⓔ CPCD15/18-XW51B Ⓒ CPCD10/15/18-XW12F ⓗ CPCD10/15/18-XW10F
Ⓛ CPQD10/15/18-XW21F

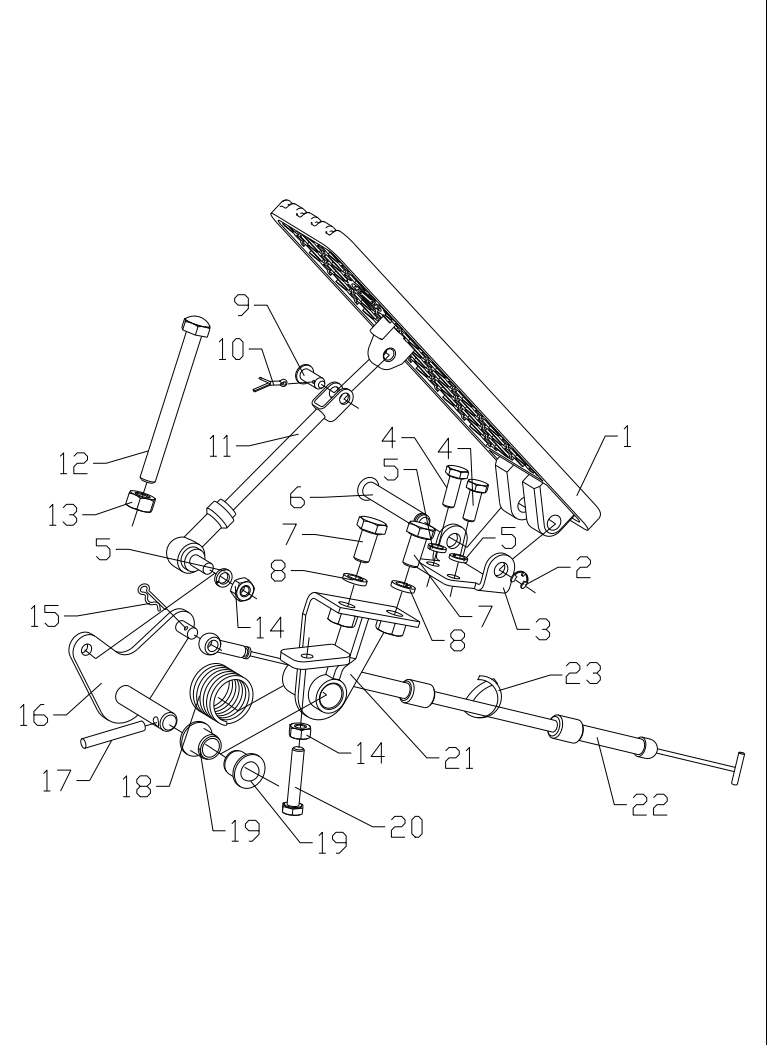
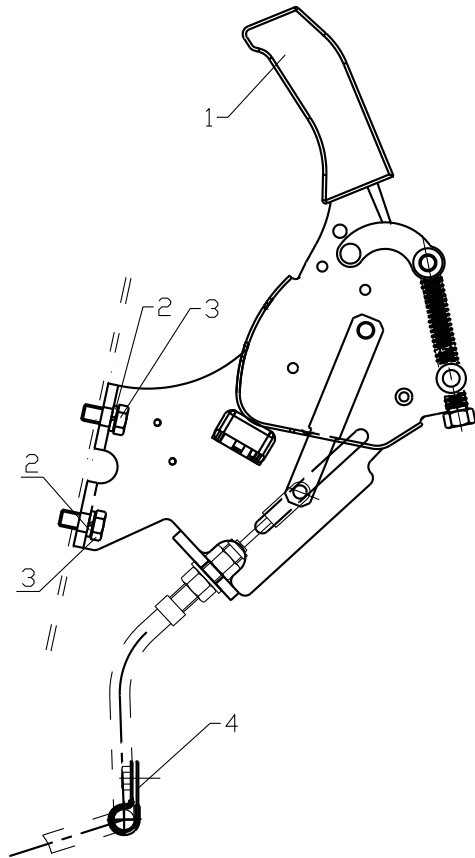

序号 Item	物料码 Part No.	名称 Description	数量 Qty	备注或适用车型 Remarks Or Serial No.
1	XF250-531000-000	驻车制动器 Parking brake control	1	
2	G000093-000010-00	垫圈 10 Washer 10	2	
3	G005783-010020-00	螺栓 M10×20 Bolt M10×20	2	≤2010-02
3	G006170-000010-00	螺母 M10 Nut M10	2	≥2010-03
4	N163-540002-000	管夹 Clip	1	

图7 驻车制动器总成

Fig.7 Handle control

©CPCD10/15/18-XW32M ⑤CPYD15/18-XW21M ⑥CPYD15/18-XW51M

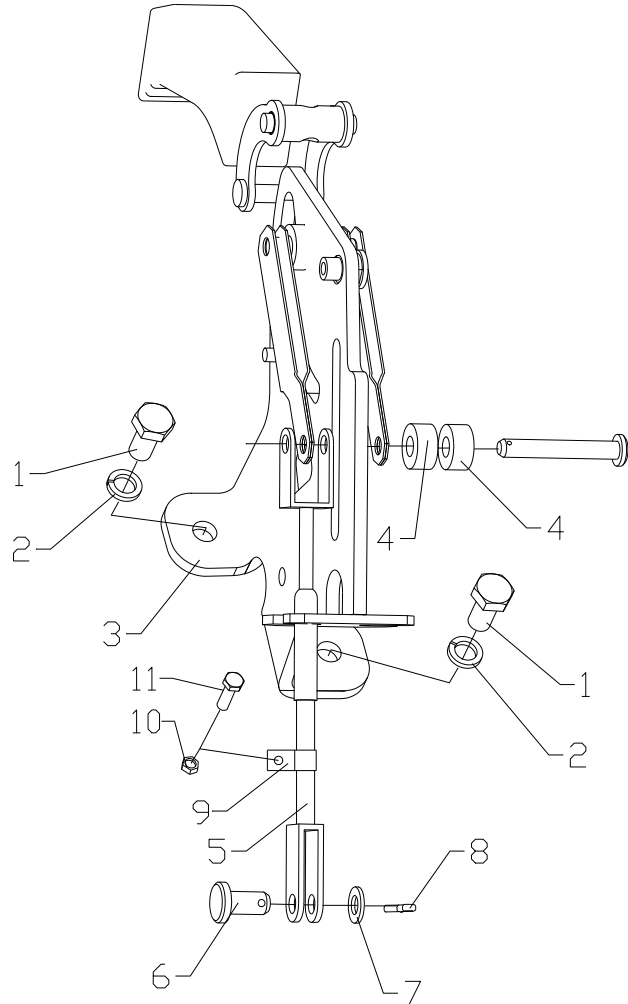

序号 Item	物料码 Part No.	名称 Description	数量 Qty	备注或适用车型 Remarks Or Serial No.
1	G005783-010020-00	螺栓 M10×20 Bolt M10×20	2	≤2010-02
1	G006170-000010-00	螺母 M10 Nut M10	2	≥2010-03
2	G000093-000010-00	垫圈 10 Washer 10	2	
3	XF250-531000-000	驻车制动器 Parking brake control	1	
4	XM250-530001-000	隔套 Sleeve	2	
5	XM250-530100-000	手制动拉线总成 Cable	1	
6	G000882-008020-01	销轴 B8×20 Pin shaft B8×20	1	
7	G0097P1-000008-00	垫圈 8 Washer 8	1	
8	G000091-3P2016-00	销 3.2×16 Pin 3.2×16	1	
9	N163-540001-000	管夹 Clip	1	
10	G006170-000008-00	螺母 M8 Nut M8	1	
11	G005783-008016-00	螺栓 M8×16 Bolt M8×16	1	

图 8 管路总成
Fig.8 Brake pipe assy

Ⓐ CPCD10/15/18-XW32F Ⓑ CPCD10/15/18-XW32B Ⓓ CPYD15/18-XW21F Ⓔ CPYD15/18-XW51F
Ⓔ CPYD15/18-XW21B Ⓔ CPCD15/18-XW51B Ⓒ CPCD10/15/18-XW12F Ⓕ CPCD10/15/18-XW10F
Ⓘ CPQD10/15/18-XW21F

序号 Item	物料码 Part No.	名称 Description	数量 Qty	备注或适用车型 Remarks Or Serial No.
1	G005783-008016-00	螺栓 M8×16 Bolt M8×16	2	
2	G000093-000008-00	垫圈 8 Washer 8	3	
3	XF250-540200-000	支架 Support	1	
4	G005783-006016-00	螺栓 M6×16 Bolt M6×16	2	
5	G000093-000006-00	垫圈 6 Washer 6	2	
6	G0097P1-000006-00	垫圈 6 Washer	2	
7	XF250-540001-000	胶管 Pipe	1	
8	Q672-19-G00	双钢丝式环箍 19 Clamp	2	
9	XF250-540100-000	油壶 Oil cup	1	
10	N163-540002-000	管夹 Clip	1	
11	G005783-008030-00	螺栓 M8×30 Bolt M8×30	1	
12	XF250-540002-000	主制动油管 Brake pipe	1	
13	XF250-540005-001	三通接头 Connector	1	XF250-540005-000
14	XF150-520001-000	左制动油管 Left brake pipe	1	
15	XF150-520002-000	右制动油管 Right brake pipe	1	

图9 管路总成
Fig.9 Brake pipe assey

© CPCD10/15/18-XW32M ⑤ CPYD15/18-XW21M ⑥ CPYD15/18-XW51M

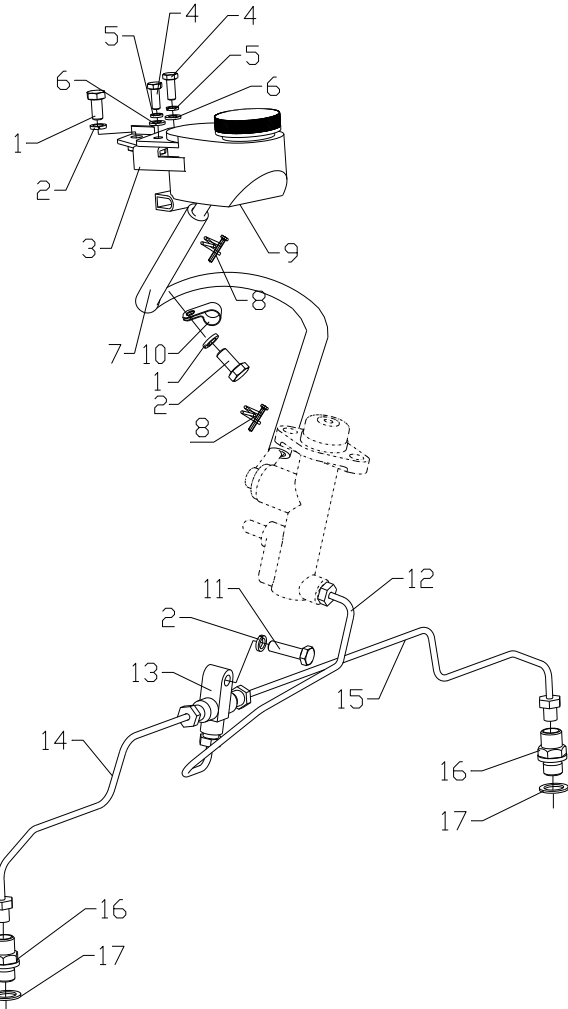

序号 Item	物料码 Part No.	名称 Description	数量 Qty	备注或适用车型 Remarks Or Serial No.
1	G005783-008016-00	螺栓 M8×16 Bolt M8×16	2	
2	G000093-000008-00	垫圈 8 Washer 8	3	
3	XF250-540200-000	支架 Support	1	
4	G005783-006016-00	螺栓 M6×16 Bolt M6×16	2	
5	G000093-000006-00	垫圈 6 Washer 6	2	
6	G0097P1-000006-00	垫圈 6 Washer 6	2	
7	XM250-540005-000	胶管 Pipe	1	
8	Q672-19-G00	双钢丝式环箍 19 Clamp 19	2	
9	XF250-540100-000	油壶 Oil cup	1	
10	N163-540002-000	管夹 Clip	1	
11	G005783-008030-00	螺栓 M8×30 Bolt M8×30	1	
12	XF250-540002-000	主制动油管 Brake pipe	1	
13	XF250-540005-001	三通接头 Connector	1	XF250-540005-000
14	XM150-540001-000	左制动油管 Left brake pipe	1	
15	XM150-540002-000	右制动油管 Right brake pipe	1	

图9 管路总成
Fig.9 Brake pipe assey

©CPCD10/15/18-XW32M ㊦CPYD15/18-XW21M ㊦1CPYD15/18-XW51M

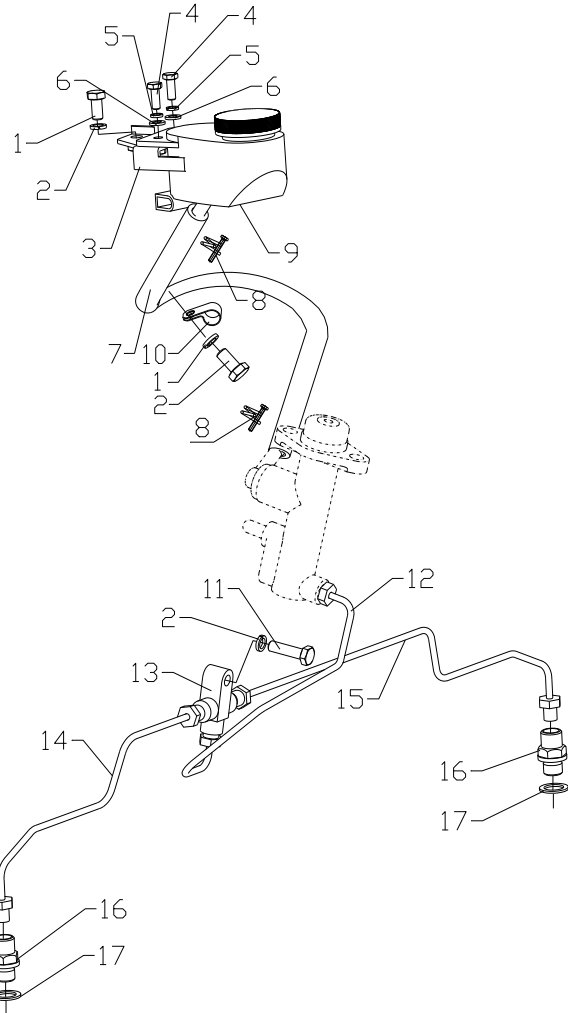

序号 Item	物料码 Part No.	名称 Description	数量 Qty	备注或适用车型 Remarks Or Serial No.
16	RM622-530004-000	接头 Joint	2	
17	J000982-000014-00	垫圈 Washer	2	

图 10 制动总泵
Fig.10 Brake pump

Ⓐ CPCD10/15/18-XW32F Ⓑ CPCD10/15/18-XW32B Ⓓ CPYD15/18-XW21F Ⓔ CPYD15/18-XW51F
Ⓔ CPYD15/18-XW21B Ⓕ CPCD15/18-XW51B Ⓖ CPCD10/15/18-XW12F Ⓖ CPCD10/15/18-XW10F
Ⓘ CPQD10/15/18-XW21F

序号 Item	物料码 Part No.	名称 Description	数量 Qty	备注或适用车型 Remarks Or Serial No.
A	XF150-511000-000	制动总泵 Brake pump	1	
1	1.08.02401013	推杆叉 Push bracket	1	
2	1.08.02501035	螺母 Nut	1	
3	1.08.02301022	推杆 Push rod	1	
4	1.08.01010037	护罩 Cover	1	
5	1.08.02101006	孔用弹性挡圈 Snap ring	1	
6	1.08.03204007	限位垫圈 Washer	1	
7	1.08.00410039	辅助皮圈 First ring	1	
8	1.08.01612251	活塞 Piston	1	
9	1.08.03201023	活塞垫片 Piston Washer	1	
10	1.08.00510029	压力皮圈 Seal ring	1	
11	1.08.01803006	弹簧座 Spring support	1	
12	1.08.01301088	弹簧 Spring	1	
13	1.08.03202032	出油阀垫片 Washer	1	
14	1.08.01201004	出油阀 Valve	1	

图 10 制动总泵
Fig.10 Brake pump

- Ⓐ CPCD10/15/18-XW32F Ⓑ CPCD10/15/18-XW32B Ⓓ CPYD15/18-XW21F Ⓔ CPYD15/18-XW51F
 Ⓔ CPYD15/18-XW21B Ⓕ CPCD15/18-XW51B Ⓖ CPCD10/15/18-XW12F Ⓖ CPCD10/15/18-XW10F
 Ⓘ CPQD10/15/18-XW21F

序号 Item	物料码 Part No.	名称 Description	数量 Qty	备注或适用车型 Remarks Or Serial No.
	15	O 型圈 19x2.65 O-ring 19x2.65	1	
	16	进油管接头 Connector	1	
	17	弹簧夹 Spring clip	1	
	18	缸体 Body cylinder	1	
	XF150-511000-000 -kit	修理包 Repair kits		INC: 7、10、14、16



图 11 制动总泵
Fig.11 Brake pump

©CPCD10/15/18-XW32M ⑤CPYD15/18-XW21M ⑥CPYD15/18-XW51M

序号 Item	物料码 Part No.	名称 Description	数量 Qty	备注或适用车型 Remarks Or Serial No.
A1	XM250-512000-000	制动总泵 Brake pump	1	
1	1.08.02401013	推杆叉 Push bracket	1	
2	1.08.02501035	螺母 Nut	1	
3	1.08.02301016	推杆 Push rod	1	
4	1.08.01016003	护罩 Cover	1	
5	1.08.02101011	孔用弹性挡圈 Snap ring	1	
6	1.08.00415074	第一辅助皮圈 First ring	1	
7	1.08.01616004	活塞 Piston	1	
8	1.08.03201007	活塞垫片 Washer	1	
9	1.08.00516001	压力皮圈 Seal ring	1	
10	1.08.01801002	第二弹簧座 Spring support	1	
11	1.08.01302106	弹簧 Spring	1	
12	1.08.01801087	弹簧座 Spring support	1	
13	1.08.01201041	出油阀 Valve	1	
14	1.08.02903011	O 型圈 19×2.65 O-ring 19×2.65	1	

图 11 制动总泵
Fig.11 Brake pump

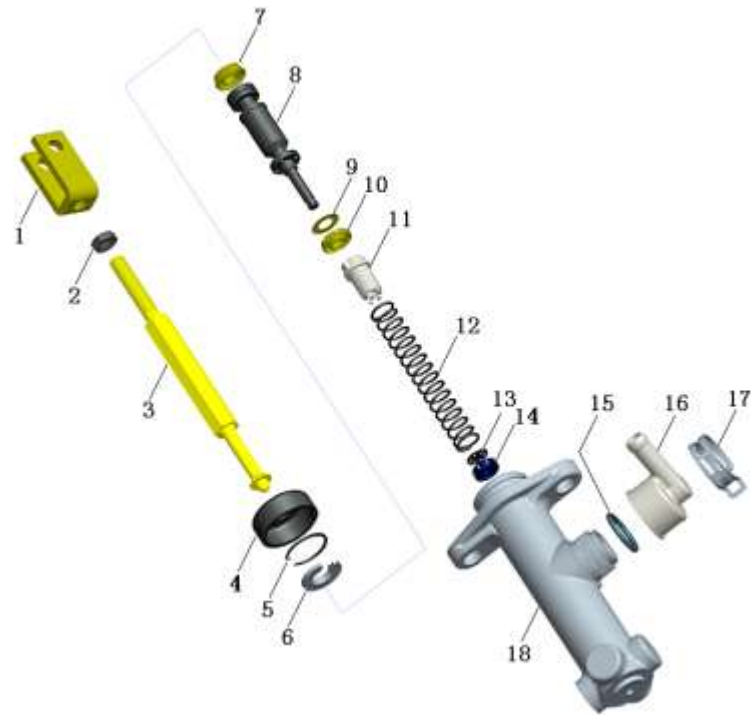
©CPCD10/15/18-XW32M ⑤CPYD15/18-XW21M ⑥CPYD15/18-XW51M

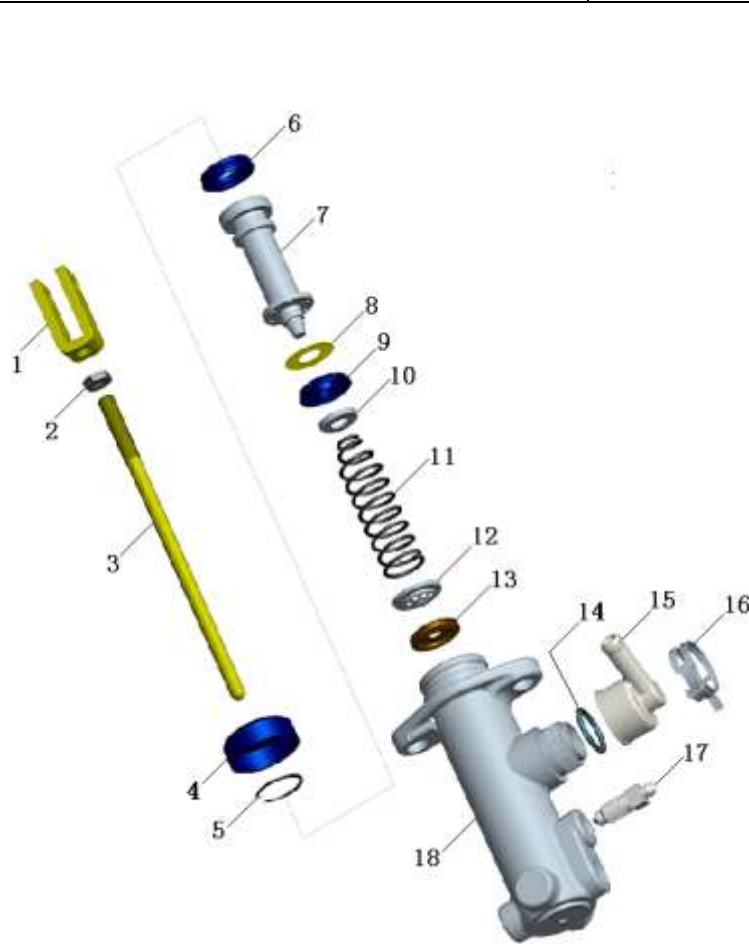

序号 Item	物料码 Part No.	名称 Description	数量 Qty	备注或适用车型 Remarks Or Serial No.
15	1.08.03002015	进油管接头 Connector	1	
16	1.08.03802007	弹簧夹 Spring clip	1	
17	1.08.03601007	放气螺钉 Screw	1	
18	2.01.TJS0116002	缸体 Body cylinder	1	
	XM250-512000-000-kit	修理包 Repair kits		INC: 6、9、13、15

