

叉车零件目录

FORKLIFT PARTS CATALOGUE

CPCD30

CD-BB

CD-CB

CD-DB

CD-EB

CD-FB

CD-RB

CD-SB

C-BB

C-CB

CPQD30

QD-FB

QD-BB

Q-BB

YD-FB

CPCD35

CD-BB

CD-CB

CD-EB

CD-RB

大连叉车有限责任公司

DALIAN FORKLIFT CO., LTD.





货叉架

Lift Bracket

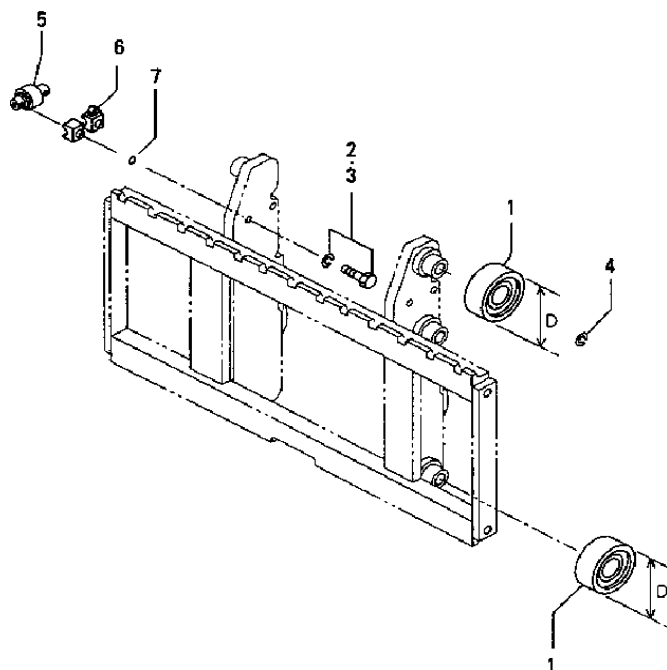

序号 Item No.	零件图号 Part No.	零部件名称 Part Description		数量 Q'ty	备注 Remark
		名称 Apellation	规格 Spec		
1	980811M-00	主滚轮 Roller,Main	D=118.7	6	选配 selective use
	980811S-00	主滚轮 Roller,Main	D=118.5	6	
	980811L-00	主滚轮 Roller,Main	D=119.7	6	
2	GB894.1	挡圈 Snap ring	55	6	
3	GB93	垫圈 Washer	12	8	
4	GB5786	螺栓 Bolt	M12×1.25×45	8	
5	L4903	侧滚轮 Side Roller		4	
6	30XDB11FD00001	垫块 Block		8	
7	30X1000013	垫圈 Shim		8组	

FORKLIFT PARTS CATALOGUE



货叉架、挡货架

Lift Bracket、Backrest

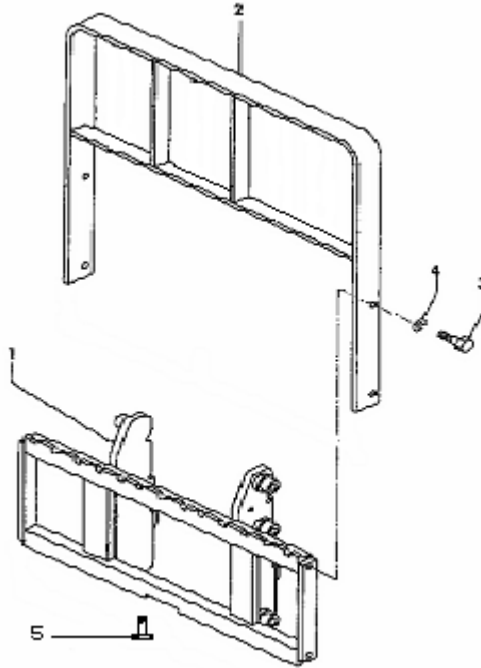

序号 Item No.	零件图号 Part No.	零部件名称 Part Description		数量 Q'ty	备注 Remark
		名称 Apellation	规格 Spec		
1	30XFB13FA10000	货叉架 Bracket		1	①②
1	35XFB13A10000	货叉架 Bracket		1	③
2	D94301-12500	挡货架 Bracket		1	①②
2	35X94301-12500	挡货架 Bracket		1	③
3	GB5786	螺栓 Bolt	M14×1.5×35	8	①②
3	GB5783	螺栓 Bolt	M16×35	8	③
4	GB93	垫圈 Washer	14	8	①②
4	GB93	垫圈 Washer	16	8	③
5	GB70.1	螺栓 Bolt	M10×1.5×16	1	



倾斜油缸

Tilt Cylinder

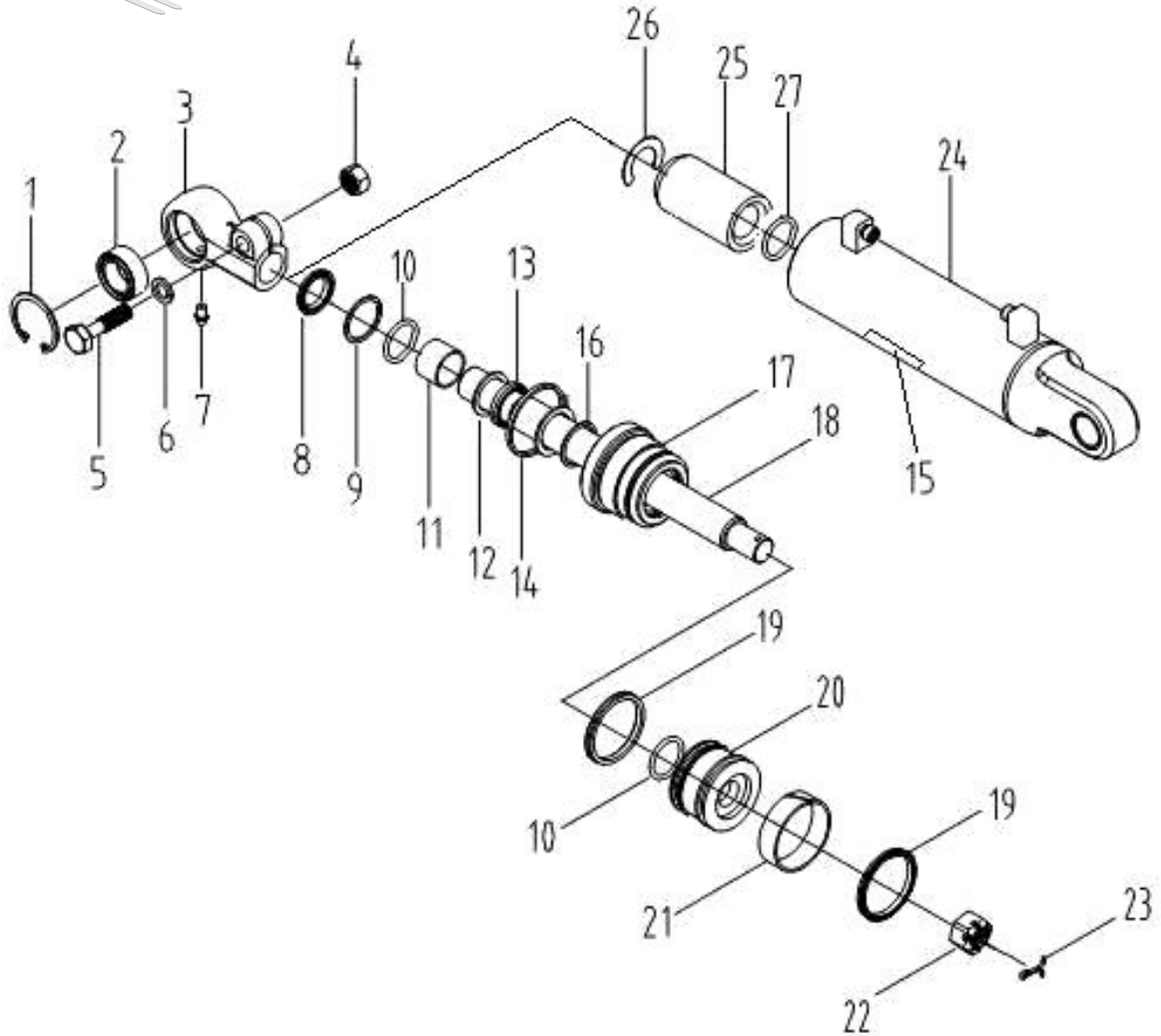

序号 Item No.	零件图号 Part No.	零部件名称 Part Description		数量 Q'ty	备注 Remark
		名称 Apellation	规格 Spec		
1	GB894.1	孔用挡圈 RING	47	1	
2	GB304.5	关节轴承 BUSHING	GE30ES	1	
3	3.0DCQ-01E	耳环 EAR RING		1	
4	GB6170	螺母 Nut	M14	1	
5	GB5782	螺栓 BOLT	M14×50	1	
6	GB859	垫圈 WASHER	14	1	

FORKLIFT PARTS CATALOGUE

序号 Item No.	零件图号 Part No.	零部件名称 Part Description		数量 Q'ty	备注 Remark
		名称 Apellation	规格 Spec		
7	JB/T7940.1	油杯 FITTING GREASE	M8×1	1	
8	CL0363C0	LBH 型防尘圈 DUST SEAL, LBH		1	
9	3.0TCMQ-04B	挡圈 SNAP RING		1	
10	GB3452.1	O 形圈 O-Ring	35503150.J1	2	
11	3.0DCQ-02D	挡圈 SNAP RING		1	
12	FU20055S0	USI Y 型密封圈 USI Y-RING		2	
13	3.0DCQ-03D	挡环 RING		1	
14	GB3452.1	O 型圈 O-RING		1	
15	-3	通用标牌 CURRENCY SCUTCHEON		1	
16	GB893.1	孔用挡圈 RING		1	
17	3.0DCQ-04D	导向套 GUIDE SLEEVE		1	
18	3.0TCMQ-12B	活塞杆 PISTON		1	
19	FU0846L0	OSI 型密封圈 OSI-RING		2	
20	3.0DCQ-05D	活塞 PISTON		1	
21	3.0DCQ-06D	支承环 WEARING		1	
22	GB9459	螺母 NUT	M24×2	1	
23	GB91	开口销 PIN	5×50	1	
24	3.0DC-10E/ZY	缸体 CYLINDER		1	
25	30XDB1FA000 006	轴套 BUSHING		1	
26	30XDB1FA000 005	调整垫 TAB		1	
27	GB3452.1	O 型圈 O-RING	31.5×3.55	1	



货叉总成
Fork Ass'y

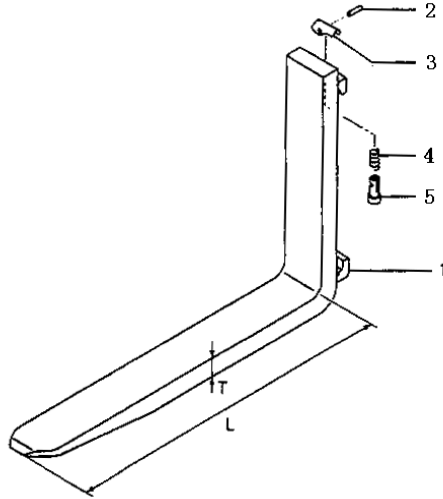

序号 Item No.	零件图号 Part No.	零部件名称 Part Description		数量 Q'ty	备注 Remark
		名称 Apellation	规格 Spec		
1	D94306-07100	货叉 Fork	L=1070 T=45	2	①②
1	D94306-07200	货叉 Fork	L=1150 T=45	2	①②
1	D94306-07300	货叉 Fork	L=1220 T=45	2	①②
1	D94306-07400	货叉 Fork	L=1370 T=45	2	①②
1	D94306-07500	货叉 Fork	L=1520 T=45	2	①②
1	D94306-07600	货叉 Fork	L=1670 T=45	2	①②
1	D94306-07700	货叉 Fork	L=1820 T=45	2	①②
1	D94306-07800	货叉 Fork	L=1970 T=45	2	①②
1	35X94306-07100	货叉 Fork	L=1070 T=50	2	③
1	35X94306-07200	货叉 Fork	L=1150 T=50	2	③
1	35X94306-07300	货叉 Fork	L=1220 T=50	2	③
1	35X94306-07400	货叉 Fork	L=1370 T=50	2	③
1	35X94306-07500	货叉 Fork	L=1520 T=50	2	③
1	35X94306-07600	货叉 Fork	L=1670 T=50	2	③

FORKLIFT PARTS CATALOGUE

序号 Item No.	零件图号 Part No.	零部件名称 Part Description		数量 Q'ty	备注 Remark
		名称 Apellation	规格 Spec		
1	35X94306-07700	货叉 Fork	L=1820 T=50	2	③
1	35X94306-07800	货叉 Fork	L=1970 T=50	2	③
2	GB879.1	销 Pin	6×28	2	
3	L94006-10400	把手 Knob		2	
4	L94006-00600	弹簧 Spring		2	
5	L94306-21100	定位销 Positioning pin		2	



内门架、外门架

Inner mast, Outer mast

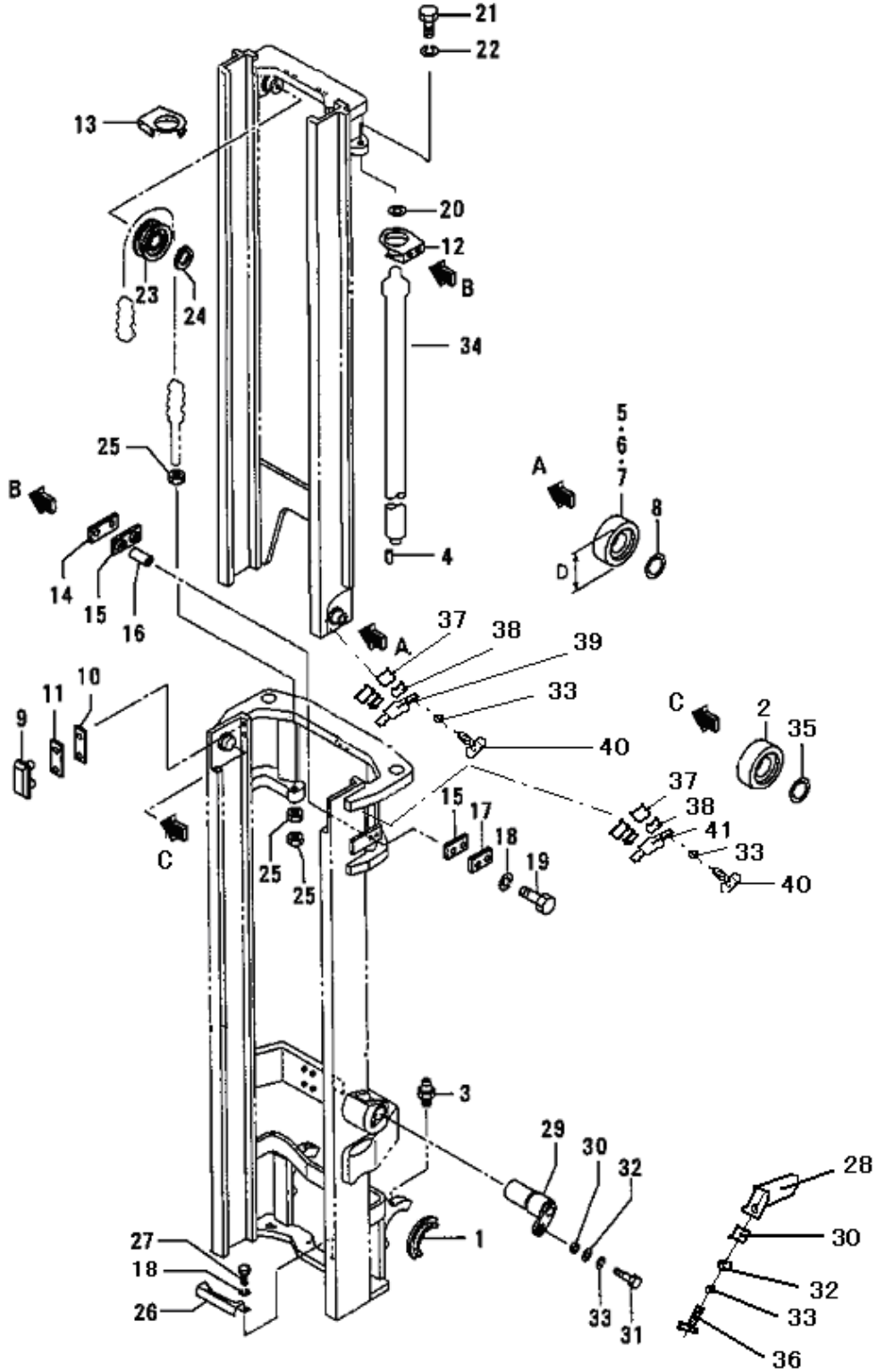

FORKLIFT PARTS CATALOGUE

序号 Item No.	零件图号 Part No.	零部件名称 Part Description		数量 Q'ty	备注 Remark
		名称 Apellation	规格 Spec		
1	30X1000015	轴衬 Bushing		2	
2	180708K	轴承 Bearing		2	
3	JB/T7940.1	油杯 Nipple	10×1	2	
4	GB879.1	销 Pin	8×18	2	
5	980811M-00	主滚轮 Roller,Main	D=118.7	2	选配 selective use
6	980811S-00	主滚轮 Roller,Main	D=118.5	2	
7	980811L-00	主滚轮 Roller,Main	D=119.7	2	
8	GB894.1	挡圈 Ring, Snap	55	2	
9	L94111-08600	限位滑块 Strip,Mast		2	
10	L94111-07400	垫片 Shim		2	
11	L94111-07500	垫片 Shim		2	
12	L94362-08800	起升缸左支架 Bracket,L		1	①②
12	L94362-18600	起升缸左支架 Bracket,L		1	③
13	L94362-08900	起升缸右支架 Bracket,L		1	①②
13	L94362-18700	起升缸右支架 Bracket,L		1	③
14	L94110-09401	垫片 Shim	T=1.5	2	
15	L94110-09500	衬垫 Cushion		4	
16	L94110-09600	限位钢管 Slipper		4	
17	L94110-09701	座 Seat		2	
18	GB93	垫圈 Spring washer	10	6	
19	GB5786	螺栓 Bolt	M10×1.25×45	4	

DALIAN FORKLIFT CO.,LTD.

序号 Item No.	零件图号 Part No.	零部件名称 Part Description		数量 Q'ty	备注 Remark
		名称 Apellation	规格 Spec		
20	L94310-02100	垫片 Shim		4	
21	GB5786	螺栓 Bolt	M16×1.5×40	2	
22	GB93	垫圈 Spring washer	16	2	
23	780309K6	链轮 Wheel , Chain		2	
24	GB894.1	挡圈 Ring, Snap	45	2	
25	GB6171	螺母 Nut	M18×1.5	6	
26	L94011-00100	压板 Board		1	
27	GB5786	螺栓 Bolt	M10×1.25×20	2	
28	L91211-22300	销轴 Pin, Tilt		2	
29	L94204-14900	倾斜缸销轴 Pin, Tilt		2	
30	L91211-23400	隔套 Spacer		4	
31	GB5786	螺栓 Bolt	M12×1.25×30	2	
32	GB97.1	垫圈 Washer	12	4	
33	GB93	垫圈 Spring washer	12	12	
34	L94321-15010	起升油缸 Lift cylinder	2.0M	2	①②
34	L94321-13020	起升油缸 Lift cylinder	2.6M	2	①②
34	L94321-13040	起升油缸 Lift cylinder	3.0M	2	①②
34	L94321-13050	起升油缸 Lift cylinder	3.3M	2	①②
34	L94321-13060	起升油缸 Lift cylinder	3.5M	2	①②
34	L94321-15020	起升油缸 Lift cylinder	3.7M	2	①②

FORKLIFT PARTS CATALOGUE

序号 Item No.	零件图号 Part No.	零部件名称 Part Description		数量 Q'ty	备注 Remark
		名称 Apellation	规格 Spec		
34	L94321-15030	起升油缸 Lift cylinder	4.0M	2	①②
34	L94321-13090	起升油缸 Lift cylinder	4.5M	2	①②
34	L94321-15040	起升油缸 Lift cylinder	5.0M	2	①②
34	L94321-16010	起升油缸 Lift cylinder	2.0M	2	③
34	L94321-14020	起升油缸 Lift cylinder	2.6M	2	③
34	L94321-14040	起升油缸 Lift cylinder	3.0M	2	③
34	L94321-16020	起升油缸 Lift cylinder	3.3M	2	③
34	L94321-16030	起升油缸 Lift cylinder	3.5M	2	③
34	L94321-16040	起升油缸 Lift cylinder	3.7M	2	③
34	L94321-16050	起升油缸 Lift cylinder	4.0M	2	③
34	L94321-16110	起升油缸 Lift cylinder	4.2M	2	③
34	L94321-14090	起升油缸 Lift cylinder	4.5M	2	③
34	L94321-16060	起升油缸 Lift cylinder	5.0M	2	③
35	GB894.1	挡圈 Ring, Snap	40	2	
36	GB5786	螺栓 Bolt	M12×1.25×25	2	
37	30XDB11FD00001	垫块 Block		8	
38	30X1000013	垫圈 Shim		12 组	
39	L4903	侧滚轮 Side Roller		2	
40	GB5786	螺栓 Bolt	M12×1.25×40	8	
41	30X1400000	侧滚轮组 I	Side Roller	2	



门架液压系统

Hydraulic System mast

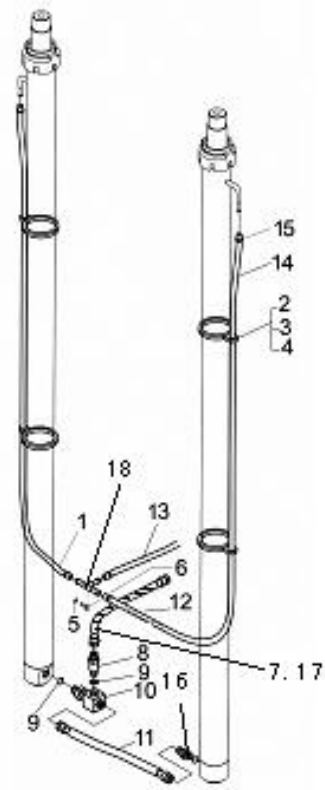

序号 Item No.	零件图号 Part No.	零部件名称 Part Description		数量 Q'ty	备注 Remark
		名称 Apellation	规格 Spec		
1	L94039-10090	胶管 Tube vinyl	2.0M	1	①②
1	L94039-10115	胶管 Tube vinyl	2.6M	1	①②
1	L94039-10140	胶管 Tube vinyl	3.0M	1	①②
1	L94039-10155	胶管 Tube vinyl	3.3M	1	①②
1	L94039-10165	胶管 Tube vinyl	3.5M	1	①②
1	L94039-10180	胶管 Tube vinyl	3.7M	1	①②
1	L94039-10195	胶管 Tube vinyl	4.0M	1	①②
1	L94039-10225	胶管 Tube vinyl	4.5M	1	①②
1	L94039-10250	胶管 Tube vinyl	5.0M	1	①②

FORKLIFT PARTS CATALOGUE

序号 Item No.	零件图号 Part No.	零部件名称 Part Description		数量 Q'ty	备注 Remark
		名称 Apellation	规格 Spec		
1	L94039-10105	胶管 Tube vinyl	2.0M	1	③
1	L94039-10130	胶管 Tube vinyl	2.6M	1	③
1	L94039-10155	胶管 Tube vinyl	3.0M	1	③
1	L94039-10165	胶管 Tube vinyl	3.3M	1	③
1	L94039-10180	胶管 Tube vinyl	3.5M	1	③
1	L94039-10190	胶管 Tube vinyl	3.7M	1	③
1	L94039-10215	胶管 Tube vinyl	4.0M	1	③
1	L94039-10225	胶管 Tube vinyl	4.2M	1	③
1	L94039-10235	胶管 Tube vinyl	4.5M	1	③
1	L94039-10260	胶管 Tube vinyl	5.0M	1	③
2	D94347-30201	管夹 Clip		4	①②
2	D94332-42601	管夹 Clip		4	③
3	GB5783	螺栓 Bolt	M6×16	4	
4	GB93	垫圈 Washer	6	4	
5	GB5786	螺栓 Bolt	M10×1.25×20	1	
6	GB93	垫圈 Washer	10	1	
7	JB1887	胶管接头 Hose	13II-640	1	
8	XSF-F16L-60α	限速阀 Flow Regulator		1	
9	GB3452.1	O形密封圈 O-Ring	18×2.65	2	
10	30XDB72FA10000	三通接头 T-Joint		1	
11	L94211-09900	胶管 Tube vinyl		1	
12	L05379-13024	螺旋管 Trachea		1	
13	L94039-01085	胶管 Tube vinyl		1	
14	L94039-10125	胶管 Tube vinyl	2.0M	1	①②
14	L94039-10150	胶管 Tube vinyl	2.6M	1	①②

DALIAN FORKLIFT CO.,LTD.

序号 Item No.	零件图号 Part No.	零部件名称 Part Description		数量 Q'ty	备注 Remark
		名称 Apellation	规格 Spec		
14	L94039-10175	胶管 Tube vinyl	3.0M	1	①②
14	L94039-10190	胶管 Tube vinyl	3.3M	1	①②
14	L94039-10200	胶管 Tube vinyl	3.5M	1	①②
14	L94039-10215	胶管 Tube vinyl	3.7M	1	①②
14	L94039-10235	胶管 Tube vinyl	4.0M	1	①②
14	L94039-10260	胶管 Tube vinyl	4.5M	1	①②
14	L94039-10285	胶管 Tube vinyl	5.0M	1	①②
14	L94039-10140	胶管 Tube vinyl	2.0M	1	③
14	L94039-10165	胶管 Tube vinyl	2.6M	1	③
14	L94039-10190	胶管 Tube vinyl	3.0M	1	③
14	L94039-10200	胶管 Tube vinyl	3.3M	1	③
14	L94039-10215	胶管 Tube vinyl	3.5M	1	③
14	L94039-10225	胶管 Tube vinyl	3.7M	1	③
14	L94039-10250	胶管 Tube vinyl	4.0M	1	③
14	L94039-10260	胶管 Tube vinyl	4.2M	1	③
14	L94039-10270	胶管 Tube vinyl	4.5M	1	③
14	L94039-10295	胶管 Tube vinyl	5.0M	1	③
15	JB/ZQ3777	喉箍 Clip	16~25	6	
16	L59036-03020	接头 Joint		1	
17	L05379-15055	螺旋管 Trachea		1	
18	L94110-27500	接头 T-Joint		1	



基本型门架
Simplex Mast

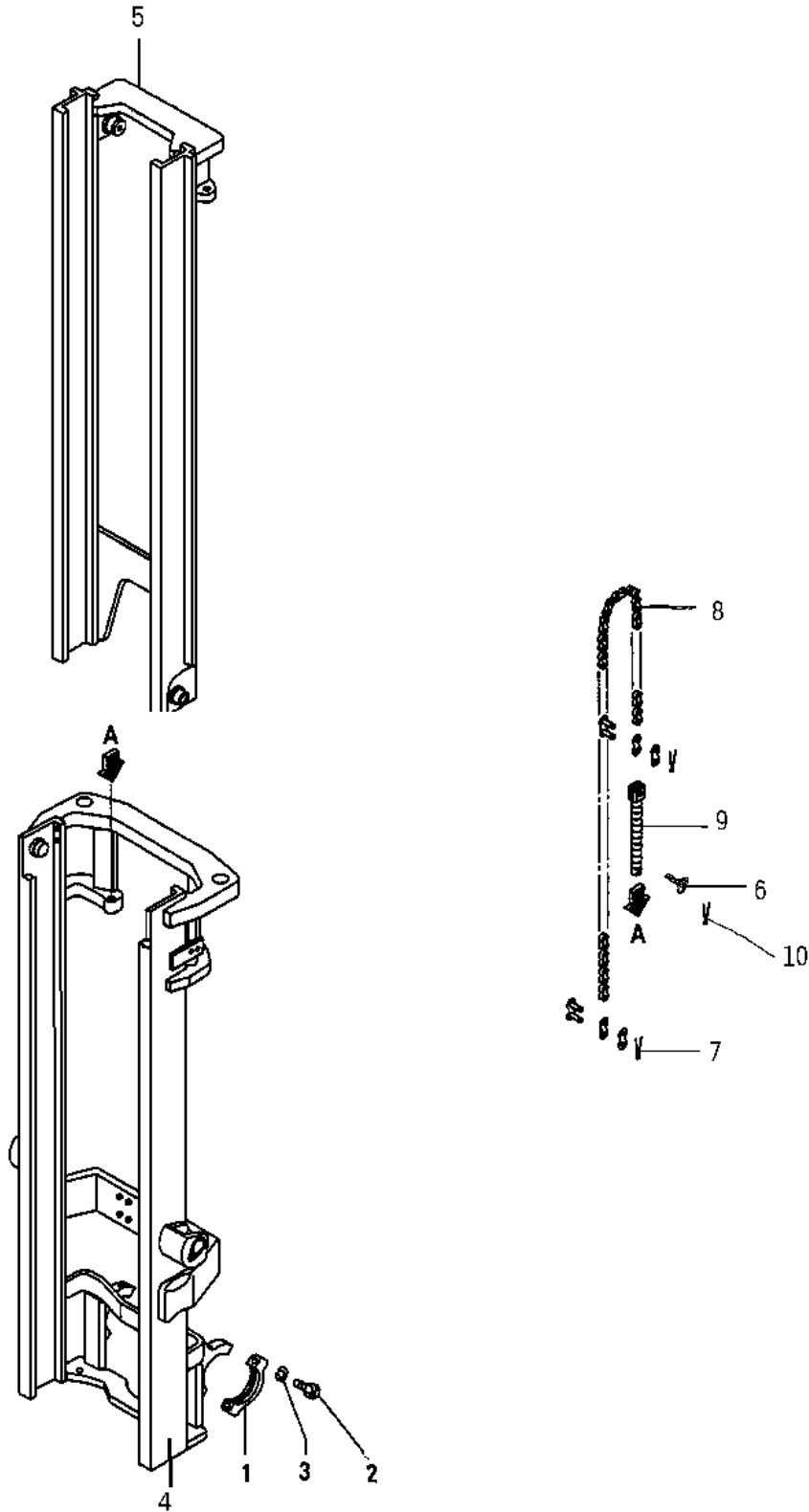

DALIAN FORKLIFT CO.,LTD.

序号 Item No.	零件图号 Part No.	零部件名称 Part Description		数量 Q'ty	备注 Remark
		名称 Apellation	规格 Spec		
1	30XDB11FA11003	支座盖 Cap		2	
2	GB5785	螺栓 Bolt	M16×1.5×65	4	
3	GB93	垫圈 Spring washer	16	4	
4	30XFB11BA10000	外门架 Outer mast	2.0M	1	①②
4	30XFB11DA10000	外门架 Outer mast	2.6M	1	①②
4	30XFB11EA10000	外门架 Outer mast	2.7M	1	①②
4	30XFB11FA10000	外门架 Outer mast	3.0M	1	①②
4	30XFB11GA10000	外门架 Outer mast	3.3M	1	①②
4	30XFB11HA10000	外门架 Outer mast	3.5M	1	①②
4	30XFB11VA10000	外门架 Outer mast	3.7M	1	①②
4	30XFB11JA10000	外门架 Outer mast	4.0M	1	①②
4	30XFB11KA10000	外门架 Outer mast	4.2M	1	①②
4	30XFB11LA10000	外门架 Outer mast	4.5M	1	①②
4	30XFB11NA10000	外门架 Outer mast	5.0M	1	①②
4	35XFB11BA10000	外门架 Outer mast	2.0M	1	③
4	35XFB11DA10000	外门架 Outer mast	2.6M	1	③
4	30XFB11GA10000	外门架 Outer mast	3.0M	1	③
4	30XFB11HA10000	外门架 Outer mast	3.3M	1	③
4	30XFB11VA10000	外门架 Outer mast	3.5M	1	③
4	35XFB11VA10000	外门架 Outer mast	3.7M	1	③
4	35XFB11JA10000	外门架 Outer mast	4.0M	1	③
4	35XFB11KA10000	外门架 Outer mast	4.2M	1	③
4	35XFB11LA10000	外门架 Outer mast	4.5M	1	③
4	35XFB11NA10000	外门架 Outer mast	5.0M	1	③
5	30XFB11BA20000	内门架 Inner mast	2.0M	1	①②
5	30XFB11DA20000	内门架 Inner mast	2.6M	1	①②

FORKLIFT PARTS CATALOGUE

序号 Item No.	零件图号 Part No.	零部件名称 Part Description		数量 Q'ty	备注 Remark
		名称 Apellation	规格 Spec		
5	30XFB11EA20000	内门架 Inner mast	2.7M	1	①②
5	30XFB11FA20000	内门架 Inner mast	3.0M	1	①②
5	30XFB11GA20000	内门架 Inner mast	3.3M	1	①②
5	30XFB11HA20000	内门架 Inner mast	3.5M	1	①②
5	30XFB11VA20000	内门架 Inner mast	3.7M	1	①②
5	30XFB11JA20000	内门架 Inner mast	4.0M	1	①②
5	30XFB11KA20000	内门架 Inner mast	4.2M	1	①②
5	30XFB11LA20000	内门架 Inner mast	4.5M	1	①②
5	30XFB11NA20000	内门架 Inner mast	5.0M	1	①②
5	35XFB11BA20000	内门架 Inner mast	2.0M	1	③
5	35XFB11DA20000	内门架 Inner mast	2.6M	1	③
5	30XFB11GA20000	内门架 Inner mast	3.0M	1	③
5	30XFB11HA20000	内门架 Inner mast	3.3M	1	③
5	30XFB11VA20000	内门架 Inner mast	3.5M	1	③
5	35XFB11VA20000	内门架 Inner mast	3.7M	1	③
5	35XFB11JA20000	内门架 Inner mast	4.0M	1	③
5	35XFB11KA20000	内门架 Inner mast	4.2M	1	③
5	35XFB11LA20000	内门架 Inner mast	4.5M	1	③
5	35XFB11NA20000	内门架 Inner mast	5.0M	1	③
6	D94330-40750-2	销轴 Pin		4	
7	GB91	销 Pin	3.2×20	4	
8	GB/T6074	链条 Chain	LH1634(55×25.4) 2.0M	2	①②
8	GB/T6074	链条 Chain	LH1634(65×25.4) 2.6M	2	①②
8	GB/T6074	链条 Chain	LH1634(67×25.4) 2.7M	2	①②
8	GB/T6074	链条 Chain	LH1634(75×25.4) 3.0M	2	①②

DALIAN FORKLIFT CO.,LTD.

序号 Item No.	零件图号 Part No.	零部件名称 Part Description		数量 Q'ty	备注 Remark
		名称 Apellation	规格 Spec		
8	GB/T6074	链条 Chain	LH1634(79×25.4) 3.3M	2	①②
8	GB/T6074	链条 Chain	LH1634(85×25.4) 3.5M	2	①②
8	GB/T6074	链条 Chain	LH1634(91×25.4) 3.7M	2	①②
8	GB/T6074	链条 Chain	LH1634(105×25.4) 4.0M	2	①②
8	GB/T6074	链条 Chain	LH1634(109×25.4) 4.2M	2	①②
8	GB/T6074	链条 Chain	LH1634(115×25.4) 4.5~5.0M	2	①②
8	GB/T6074	链条 Chain	LH1634(59×25.4) 2.0M	2	③
8	GB/T6074	链条 Chain	LH1634(69×25.4) 2.6M	2	③
8	GB/T6074	链条 Chain	LH1634(79×25.4) 3.0M	2	③
8	GB/T6074	链条 Chain	LH1634(85×25.4) 3.3M	2	③
8	GB/T6074	链条 Chain	LH1634(91×25.4) 3.5M	2	③
8	GB/T6074	链条 Chain	LH1634(95×25.4) 3.7M	2	③
8	GB/T6074	链条 Chain	LH1634(115×25.4) 4.0~4.5M	2	③
8	GB/T6074	链条 Chain	LH1634(135×25.4) 5.0M	2	③
9	D94330-40750-1	链条接头 Connector		2	
10	GB91	销 Pin	3.2×40	2	

FORKLIFT PARTS CATALOGUE



起升油缸
Lift Cylinder

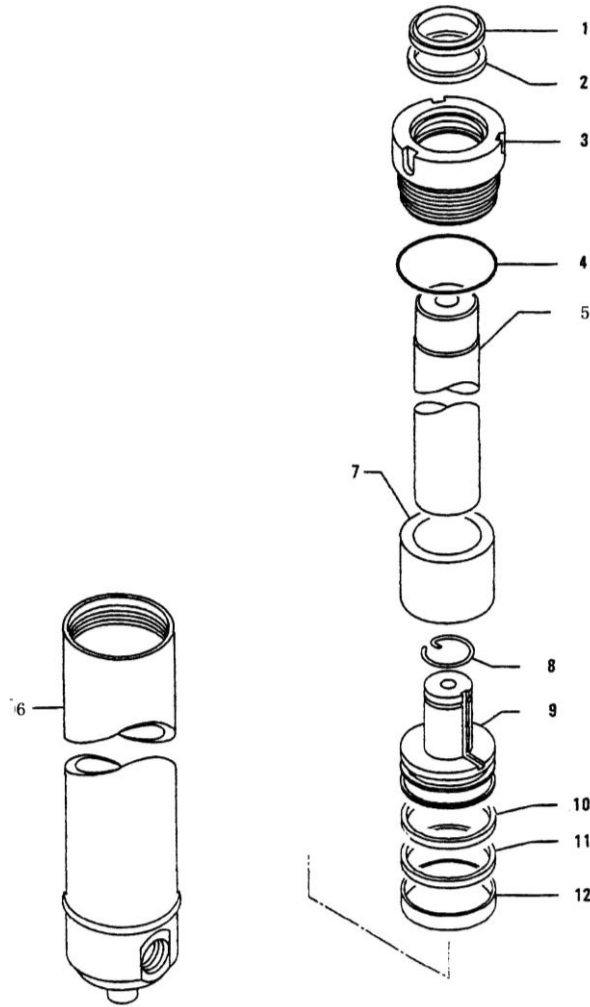

序号 Item No.	零件图号 Part No.	零部件名称 Part Description		数量 Q'ty	备注 Remark
		名称 Apellation	规格 Spec		
1	CL0085C0	LBH 型防尘圈 Seal,Dust	45×53×5/6.5	2	
2	FU0567K0	ISI 型密封圈 Seal	45×55×6	2	
3	DCS55/45.S-01	导向套 Sleeve,Guide		2	①②
3	DCS60/45,S-01	导向套 Sleeve,Guide		2	③
4	GB3452.1	O 形密封圈 O-ring	50×2.65	2	①②
4	GB3452.1	O 形密封圈 O-ring	53×3.55	2	③

DALIAN FORKLIFT CO.,LTD.

序号 Item No.	零件图号 Part No.	零部件名称 Part Description		数量 Q'ty	备注 Remark
		名称 Apellation	规格 Spec		
5	DCS55/45.1000-02	活塞杆 Rod,Piston	2.0M	2	①②
5	DCS55/45.1280-02	活塞杆 Rod,Piston	2.6M	2	①②
5	DCS55/45.1515-02	活塞杆 Rod,Piston	3.0M	2	①②
5	DCS55/45.1635-02	活塞杆 Rod,Piston	3.3M	2	①②
5	DCS55/45.1755-02	活塞杆 Rod,Piston	3.5M	2	①②
5	DCS55/45.1850-02	活塞杆 Rod,Piston	3.7M	2	①②
5	DCS55/45.2000-02	活塞杆 Rod,Piston	4.0M	2	①②
5	DCS55/45.2250-02	活塞杆 Rod,Piston	4.5M	2	①②
5	DCS55/45.2500-02	活塞杆 Rod,Piston	5.0M	2	①②
5	DCS60/45.1000-02	活塞杆 Rod,Piston	2.0M	2	③
5	DCS60/45.1285-02	活塞杆 Rod,Piston	2.6M	2	③
5	DCS60/45.1500-02	活塞杆 Rod,Piston	3.0M	2	③
5	DCS60/45.1650-02	活塞杆 Rod,Piston	3.3M	2	③
5	DCS60/45.1765-02	活塞杆 Rod,Piston	3.5 M	2	③
5	DCS55/45.1860-02	活塞杆 Rod,Piston	3.7 M	2	③
5	DCS60/45.2000-02	活塞杆 Rod,Piston	4.0M	2	③
5	DCS60/45.2250-02	活塞杆 Rod,Piston	4.5M	2	③
5	DCS55/45.2500-02	活塞杆 Rod,Piston	5.0M	2	③
6	DCS55/45.1000-10	缸体 Tube,Cylinder	2.0M	2	①②
6	DCS55/45.1280-10	缸体 Tube,Cylinder	2.6M	2	①②

FORKLIFT PARTS CATALOGUE

序号 Item No.	零件图号 Part No.	零部件名称 Part Description		数量 Q'ty	备注 Remark
		名称 Apellation	规格 Spec		
6	DCS55/45.1515-10	缸体 Tube,Cylinder	3.0M	2	①②
6	DCS55/45.1635-10	缸体 Tube,Cylinder	3.3M	2	①②
6	DCS55/45.1755-10	缸体 Tube,Cylinder	3.5 M	2	①②
6	DCS55/45.1850-10	缸体 Tube,Cylinder	3.7 M	2	①②
6	DCS55/45.2000-10	缸体 Tube,Cylinder	4.0M	2	①②
6	DCS55/45.2250-10	缸体 Tube,Cylinder	4.5M	2	①②
6	DCS55/45.2500-10	缸体 Tube,Cylinder	5.0M	2	①②
6	DCS60/45.1000-10	缸体 Tube,Cylinder	2.0M	2	③
6	DCS60/45.1285-10	缸体 Tube,Cylinder	2.6M	2	③
6	DCS60/45.1500-10	缸体 Tube,Cylinder	3.0M	2	③
6	DCS60/45.1650-10	缸体 Tube,Cylinder	3.3M	2	③
6	DCS60/45.1765-10	缸体 Tube,Cylinder	3.5M	2	③
6	DCS60/45.1860-10	缸体 Tube,Cylinder	3.7M	2	③
6	DCS60/45.2000-10	缸体 Tube,Cylinder	4.0M	2	③
6	DCS60/45.2250-10	缸体 Tube,Cylinder	4.5M	2	③
6	DCS60/45.2500-10	缸体 Tube,Cylinder	5.0M	2	③
7	DCS55/45.S-03	限位套 Spacer		2	①②
7	DCS60/45.S-03	限位套 Spacer		2	③
8	GB895.1	孔用钢丝挡圈 Ring, Wear	25	2	
9	DCS55/45.S-04	活塞 Piston		2	①②
9	DCS60/45.S-04	活塞 Piston		2	③
10	30CJA75-8W-S-06	保护圈 Ring, Guard		2	①②
10	DCS60/45.S-05	保护圈 Ring, Guard		2	③
11	FU0692L0	OSI 型密封圈 OSI Seal	55×45×6	2	①②
11	FU0742L0	OSI 型密封圈 OSI Seal	60×50×6	2	③
12	DCS55/45.S-05	支承圈 Ring, Retaining		2	①②
12	DCS60/45.S-06	支承圈 Ring, Retaining		2	③



传动系统 (液力式)

Drive System

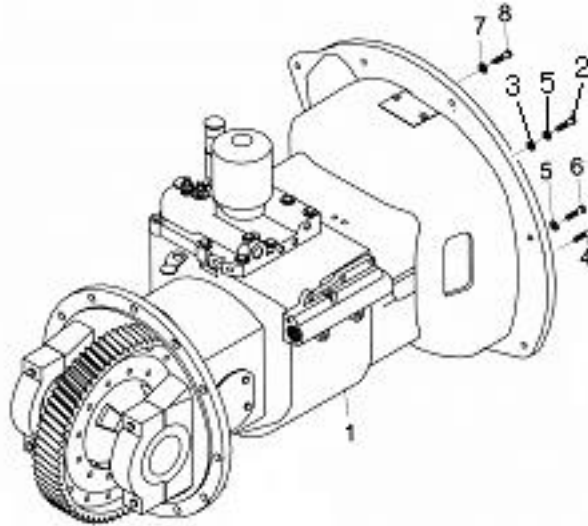

序号 Item No.	零件图号 Part No.	零部件名称 Part Description		数量 Q'ty	备注 Remark
		名称 Apellation	规格 Spec		
1	YQX30A	变速箱 Drive unit		1	①-1~3 ③-1、2
1	YQXD30A	变速箱 Drive unit		1	①-4、③-3
1	YQXD30	变速箱 Drive unit		1	①-5、6、9 ③-4
1	YQXD30C	变速箱 Drive unit		1	②-2、4
1	YQX30H1	变速箱 Drive unit		1	②-1
2	GB5783	螺栓 Bolt	M10×45	7	②-2、4
2	GB5783	螺栓 Bolt	M10×45	1	①-5、6、9 ③-4
3	GB6170	螺母 Nut	M10	7	②-2、4
3	GB6170	螺母 Nut	M10	1	①-5、6、9 ③-4
4	GB119.2	销 Pin	6×16	3	①-1~4 ②-2、4 ③-1~3
4	GB119.2	销 Pin	6×16	2	①-5、6、9 ②-1 ③-4
5	GB93	垫圈 Washer	10	9	①-1~4 ②-2、4 ③-1~3
5	GB93	垫圈 Washer	10	8	①-5、6、9 ②-1 ③-4
6	GB5783	螺栓 Bolt	M10×35	9	①-1~4 ③-1~3

FORKLIFT PARTS CATALOGUE

6	GB5783	螺栓 Bolt	M10×35	8	②-1
---	--------	---------	--------	---	-----

序号 Item No.	零件图号 Part No.	零部件名称 Part Description		数量 Q'ty	备注 Remark
		名称 Apellation	规格 Spec		
6	GB5783	螺栓 Bolt	M10×35	7	①-5、6、9 ③-4
6	GB5783	螺栓 Bolt	M10×35	2	②-2、4
7	GB93	垫圈 Washer	8	6	①-1~4 ②-2、4 ③-1~3
7	GB93	垫圈 Washer	8	12	①-5、6、9 ②-1 ③-4
8	GB5783	螺栓 Bolt	M8×20	6	①-1~4 ②-2、4 ③-1~3
8	GB5783	螺栓 Bolt	M8×20	12	①-5、6、9 ②-1 ③-4



传动系统(机械式)

Drive System(Clutch Type)

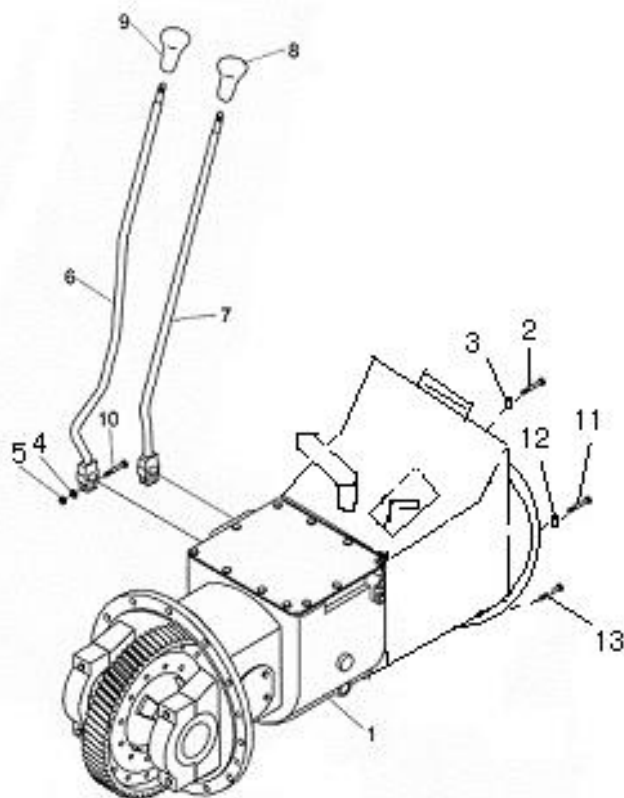

序号 Item No.	零件图号 Part No.	零部件名称 Part Description		数量 Q'ty	备注 Remark
		名称 Apellation	规格 Spec		
1	JDS30II	变速箱 Drive unit		1	①-7、①-8
1	JDS30IIIH1	变速箱 Drive unit		1	②-3
2	GB5783	螺栓 Bolt	M8×20	6	①-7、①-8
2	GB5783	螺栓 Bolt	M8×20	12	②-3
3	GB93	垫圈 Washer	8	6	①-7、①-8
3	GB93	垫圈 Washer	8	12	②-3
4	GB859	垫圈 Washer	8	2	①-7、①-8 ②-3
5	GB6170	螺母 Nut	M8	2	①-7、①-8 ②-3
6	30W6510000	速度变换手柄 Lever, speed change		1	①-7、①-8 ②-3

FORKLIFT PARTS CATALOGUE

序号 Item No.	零件图号 Part No.	零部件名称 Part Description		数量 Q'ty	备注 Remark
		名称 Apellation	规格 Spec		
7	30W6520000	方向变换手柄 Lever,direction		1	①-7、①-8 ②-3
8	30CJA13-00100	方向手球 Knob, direction		1	①-7、①-8 ②-3
9	30CJA13-00200	速度手球 Knob, speed		1	①-7、①-8 ②-3
10	GB5782	螺栓 Bolt	M8×35	2	①-7、①-8 ②-3
11	GB5783	螺栓 Bolt	M10×35	9	①-7、①-8
11	GB5783	螺栓 Bolt	M10×35	8	②-3
12	GB93	垫圈 Spring Washer	10	9	①-7、①-8
12	GB93	垫圈 Spring Washer	10	8	②-3
13	GB119.2	销 Pin	6×16	2	①-7、①-8②-3



驱动桥
Drive Axle

驱 动 桥

整机可装配的驱动桥有两种：一种为主机厂自制生产；一种为安庆车桥厂生产。您在查阅这部分的零件目录时，请先确认您的叉车上安装的是哪一种。无标签的为主机厂自制的驱动桥，带有“安庆车桥厂”字样标签的为安庆车桥厂的驱动桥。对应的驱动桥零件目录共分两部分，请注意确认。为保证准确请您在选择备件时一定要提供整机出厂编号。由此造成的不便请您见谅！

DRIVE AXLE

In this chapter, you can see two kinds of Drive Axle and the Parts Manual of their each .You need to know the type of the drive axle on your forklift truck, before reading this chapter. If there is a label marks the letters“安庆车桥厂” on the axle body ,it is made of ANQING AXLE FACTORY .So you can read the part 2. And if there is no label on the axle body, it is made of DALIAN FORKLIFT CO.,LTD. So you can read the part 1. To avoid mistake, when ordering parts, give the DALIAN forklift trucks dealer or distributor the serial number of the forklift truck .Beg your pardon for the discomfort with it !

FORKLIFT PARTS CATALOGUE

第 1 部分 (Part 1) 自制驱动桥 (MADE OF DALIAN FORKLIFT CO., LTD.)

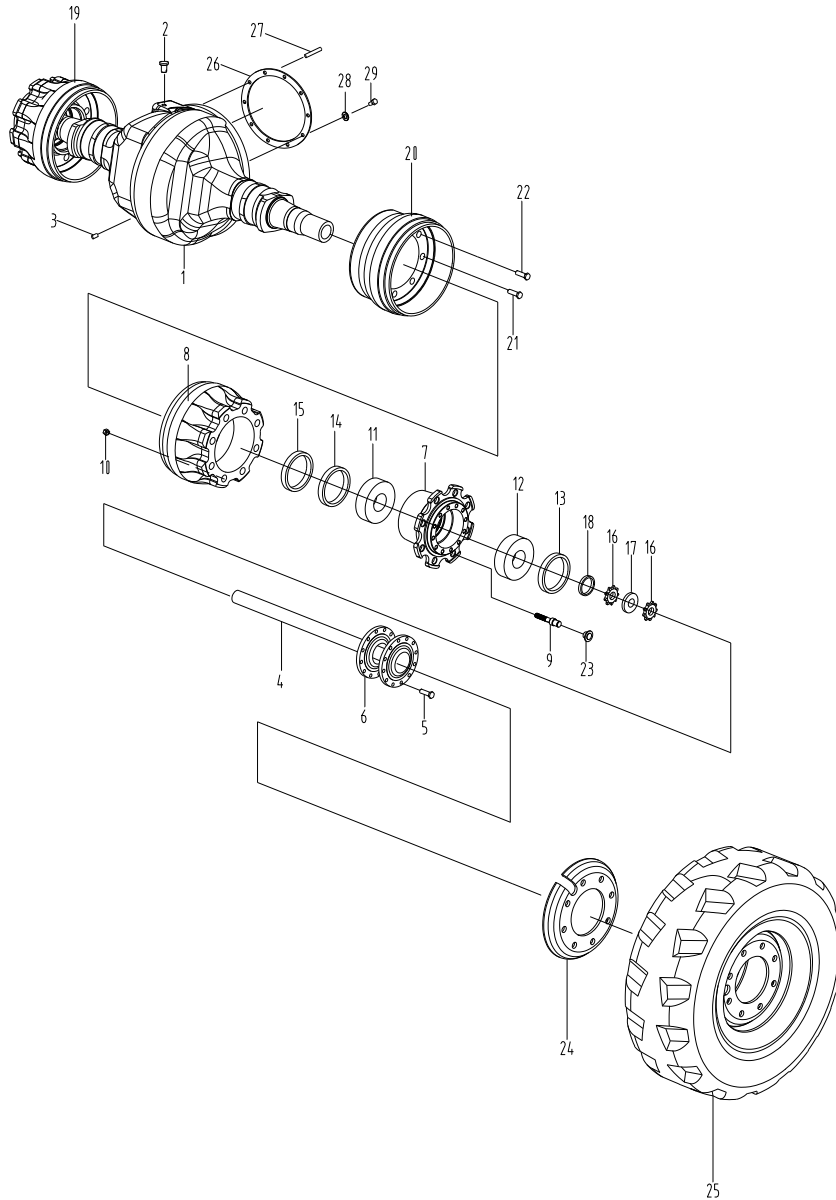

序号 Item No.	零件图号 Part No.	零部件名称 Part Description		数量 Q`ty	备注 Remark
		名称 Apellation	规格 Spec		
1	30X2100008	驱动桥壳 Housing, Axle		1	
2	JB/ZQ4446	螺塞 Plug, Hole	R1/2	2	
3	100X2160000	通气装置 Plug, Hole		1	
4	30X2100007	半轴 Shaft, Drive		2	

DALIAN FORKLIFT CO.,LTD.

序号 Item No.	零件图号 Part No.	零部件名称 Part Description		数量 Q`ty	备注 Remark
		名称 Apellation	规格 Spec		
5	30X2100006	螺栓 Bolt		24	
6	30X2100009	垫片 Shim		2	
7	30X2100002	前轮毂 Hub, Front		2	
8	30X2100001	制动毂 Drum, Brake		2	
9	30X2100003	螺栓 Bolt		12	
10	GB6171	螺母 Nut	M20×1.5	12	
11	7214E	轴承 Bearing, Taper		2	
12	2007112E	轴承 Bearing, Taper		2	
13	HG4-692-67	油封 Seal Oil	SD70×100×12	2	
14	HG4-692-67	油封 Seal Oil	SD100×130×12	2	
15	30X2100010	挡块 Washer		2	
16	GB810	螺母 Washer Block	M60×2	4	
17	GB858	垫圈 Washer	60	2	
18	30X2100005	挡块 Retainer		2	
19	30X2120000	制动器总成 (右) Wheel Brake. R.H		1	
20	30X2110000	制动器总成 (左) Wheel Brake. L.H		1	
21	30X2100011	螺栓 Bolt		12	
22	20X2100008	螺栓 Bolt		4	
23	30X2100004	轮毂螺母 Nut		12	
24	30130-01000	轮辋 Rim		2	
25	GB/T2982-1991	轮胎 Tire	28×9-15-14PR	2	①②
25	250-15-16PR	轮胎 (配 7.00×15 轮辋) Tire		2	③
26	30X2100014	密封垫圈 Seal Cushion		1	
27	GB119. 2	销 Pin	B10×30	1	
28	GB93	垫圈 Washer	12	36	
29	30X2100013	螺栓 Bolt	M12	12	

FORKLIFT PARTS CATALOGUE



制动器

Wheel Brake

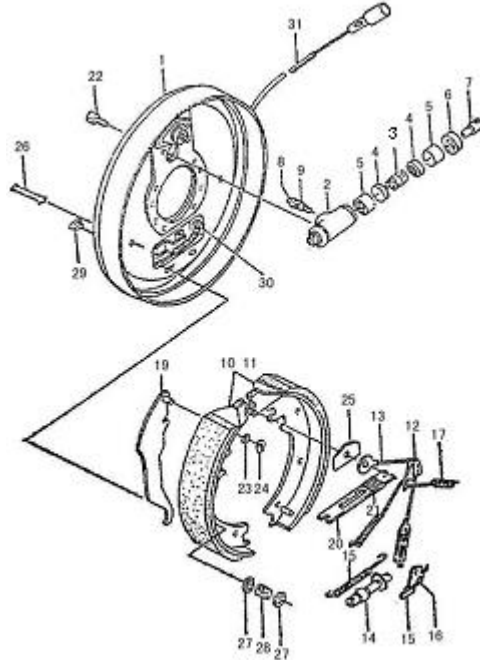

序号 Item No.	零件图号 Part No.	零部件名称 Part Description		数量 Q`ty	备注 Remark
		名称 Apellation	规格 Spec		
1	24433-72000G	制动器底板总成(左) Back Plate.L.H		1	
		制动器底板总成(右) Back Palte.R.H		1	
2	24433-76000G	制动分泵总成 Cylinder, Master		1	
3		弹簧 Spring		2	
4		皮碗 Cup, Rubber		2	
5		活塞 Piston		4	
6		护罩 Boot		4	
7		活塞顶杆 Link, Connecting		4	
8		放气螺钉帽 Cab, leader		4	
9		放气螺钉 Screw, leader		2	
10	24433-71000G	制动蹄带摩擦片总成(前) Shoe Lining		2	
11	24433-75000G	制动蹄带摩擦片总成(后) Shoe Lining		2	

DALIAN FORKLIFT CO.,LTD.

序号 Item No.	零件图号 Part No.	零部件名称 Part Description		数量 Q'ty	备注 Remark
		名称 Apellation	规格 Spec		
12	24433-70080G	导向块 Guide, Cable		2	
13	24433-73000G	弹簧拉线装置 Spring Fitting Ass'y		2	
14	24433-74000G	间隙调整器总成(左) Adjuster (L)		1	
15	24433-70100G	棘爪 Pallet		1	
16	24433-70090G	弹簧 Spring Lever Return		1	
17	24433-70070G	制动蹄回位弹簧(左) Spring L.H		2	
		制动蹄回位弹簧(右) Spring R.H		1	
18	24433-70050G	回位弹簧 Spring		1	
19	24433-70140G	手制动拉杆(左) Lever L.H Parking		1	
		手制动拉杆(右) Lever R.H Parking		1	
20	24433-70120G	手制动推杆(左) Strut L.H		1	
		手制动推杆(右) Strut R.H		1	
21	24433-70130G	弹簧 Spring		1	
22		螺栓和垫圈 Bolt lock Washer		2	
23	24433-70160G	弹性垫片 Washer Lock		1	
24	24433-70170G	杆销挡圈 Retainer		1	
25	24433-70060G	导向板 Plate Shoe Guide		1	
26	24433-70010G	压簧拉杆 Pin Shoe Hold Down		2	
27	24433-70020G	压簧座 Cup, Shoe Hold Down		2	
28	24433-70030G	压簧 Slingshot Hole Down		2	
29	24433-70040G	胶堵 Cover, Adjusting Hole		1	
30		挡圈 Ring, Snap		2	
31	OC11246-14603	制动钢索总成(左) Parking Cable L.H		1	
	OC11246-24603	制动钢索总成(右) Parking Cable R.H		1	

FORKLIFT PARTS CATALOGUE

第 2 部分 (Part 2)



安庆车桥厂驱动桥

(MADE OF AN QING AXLE FACTORY)

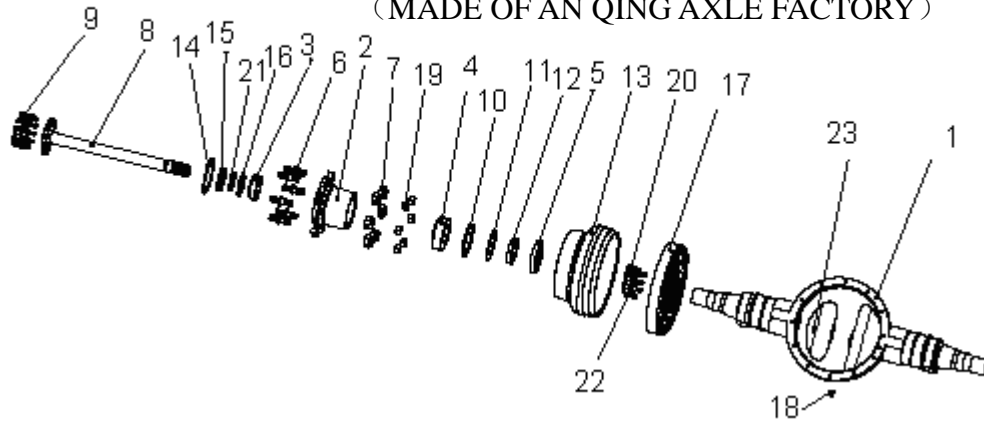

序号 Item No.	零件图号 Part No.	零部件名称 Part Description		数量 Q'ty	备注 Remark
		名称 Apellation	规格 Spec		
1	A22J3-02021	桥壳 Housing, axle		1	
2	24453-02031	轮毂 Hub		2	
3	GB/T307.1-205	轴承 Bearing	33012	2	
4	GB/T307	轴承 Bearing	33214	2	
5	26531-01004	油封 Oil seal		2	
6	24453-02061	轮毂螺栓 Hub, bolt		12	
7	23913-02041	轮毂螺母 Hub, nut		12	
8	A22J3-02011	半轴 Axle shaft		2	
9	24453-02061	螺栓 (半轴用) bolt for Axle shaft		24	
10	22493-00020G	备用垫 Washer		2	
11	22493-00030G	挡油圈 Oil seal		2	
12	24453-02121G	油封挡圈 Oil seal		2	
13	24453-02131	制动鼓 Drum		2	
14	A22A3-02031	半轴垫 Paper washer for Axle		2	
15	GB810-88	圆螺母 Ring nut		4	
16	GB858-88	圆螺母止动垫圈 Washer		2	

DALIAN FORKLIFT CO.,LTD.

序号 Item No.	零件图号 Part No.	零部件名称 Part Description		数量 Q'ty	备注 Remark
		名称 Apellation	规格 Spec		
17	HRA22-J3701-HST	制动器 Wheel brake		2	
18	22193-03001	堵塞 Plug		3	
19	GB6171	螺母 Nut	M20	12	
20	A22A3-02051	螺栓 (3t 制动器用) Bolt (3t)		12	
21	23453-02091	垫 Washer		2	
22	25953-72001	螺栓 (制动器用) Bolt		4	
23	90106-65900	通气塞总成 Vent-plug		1	

FORKLIFT PARTS CATALOGUE



发动机
Engine

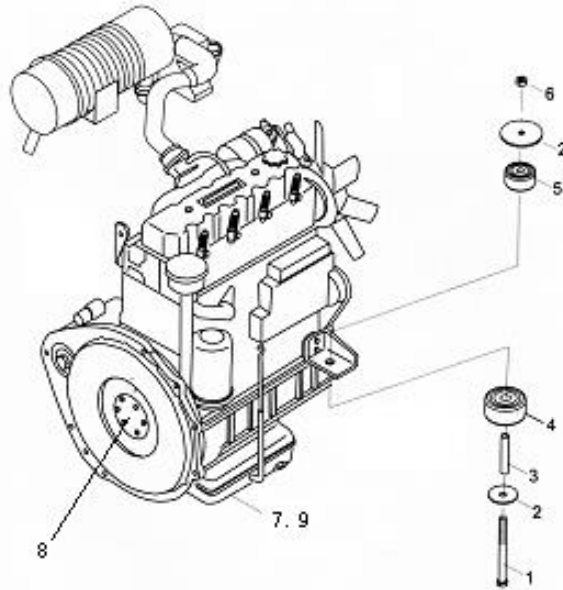

序号 Item No.	零件图号 Part No.	零部件名称 Part Description		数量 Q'ty	备注 Remark
		名称 Apellation	规格 Spec		
1	GB5785	螺栓 Bolt	M12×1.5×90	2	①-2-4、7、8 ③-2、3
1	GB5785	螺栓 Bolt	M12×1.5×85	2	②-1、3
1	GB5785	螺栓 Bolt	M10×1.25×90	2	①-1、5、6 ②-2、4 ③-1、4
2	30WBA9100001	垫 Plate		4	①-1-4、6、7 ②-1、3 ③-2、3
2	30X9100003	垫 Plate		4	①-1、5、6 ②-2、4 ③-1、4
2	TD35769	支撑垫 Plate		2	①-1、③-1
3	30WBA9100004	限位钢管 Steel tube		2	①-2、3、4、7、8 ③-2、3
3	30VBB3100001	限位钢管 Steel tube		2	②-1、3
3	30V9100006	限位钢管 Steel tube		2	①-1、5、6 ②-2、4 ③-1、4
3	TD761311	管套 Steel tube		2	①-1、③-1
4	30WBA9100003	中垫 Rubber		2	①-2-4、7、8 ②-1、3、③-2、3
4	30X9100005	中垫 Rubber		2	①-1、5、6 ②-2、4 ③-1、4

DALIAN FORKLIFT CO.,LTD.

序号 Item No.	零件图号 Part No.	零部件名称 Part Description		数量 Q`ty	备注 Remark
		名称 Apellation	规格 Spec		
4	216G1-02111	缓冲垫 Rubber		1	①-1、③-3
5	30WBA9100002	上垫 Rubber		2	①-2~4、7、8 ②-1、3③-2、3
5	30X9100004	上垫 Rubber		2	①-1、5、6 ②-2、4③-1、4
5	214A1-02111A	缓冲垫 Rubber		1	①-1、9③-1
6	GB889	尼龙锁紧螺母 Nut	M12×1.5	2	①-2~4、7、8 ②-1、3③-2、3
6	GB889	尼龙锁紧螺母 Nut	M10×1.25	2	①-1、5、6 ②-2、4③-1、4
7	A490BPG-50	发动机 Engine		1	①-2、①-8
7	490BPG-50	发动机 Engine		1	①-3、①-7
7	A490BPG-50A	发动机 Engine		1	①-4
7	C240PKJ	发动机 Engine		1	①-5
7	4JG2PE	发动机 Engine		1	①-6、③-4
7	H25	发动机 Engine		1	②-2、4
7	WF491GP	发动机 Engine		1	②-1、3
7	A498BPG-9	发动机 Engine		1	③-2
7	A498BPG-9A	发动机 Engine		1	③-1
7	CA498-G153	发动机 Engine		1	①-1、③-1
7	4TNE98-BQFLC	发动机 Engine		1	①-9
8	GB276	滚动轴承 Bearing	6002-2Z	1	②-1、②-3
9	DTFSF-R1/4	发动机放水阀 Valve		1	①-5、6 ②-1、 2、4③-1、4

FORKLIFT PARTS CATALOGUE



空滤器安装

Air Cleaner Ass'y

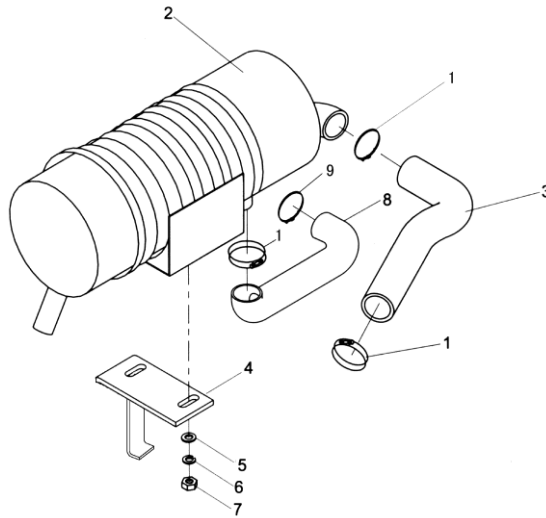

序号 Item No.	零件图号 Part No.	零部件名称 Part Description		数量 Q'ty	备注 Remark
		名称 Apellation	规格 Spec		
1	JB/ZQ3777-86	喉箍 Clip	60-80	3	①-2~4, 6~8 ③-2~4
1	JB/ZQ3777-86	喉箍 Clip	60-80	2	①-1 ~ 5、9② ③-1
2	KW1122A	空滤器总成 Air cleaner ass'y		1	①-2~8 ② ③-2~4
2	KYG-5	空滤器总成 Air cleaner ass'y		1	①-1、③-1
2	KW1122A-0100	空滤器滤芯总成 Air filter core		1	①-2~8 ② ③-2~4
2	KYG-5-1	空滤器滤芯总成 Air filter core		1	①-1、③-1
3	30XDA3400001A	发动机进气管 Duct		1	①-2~4、7、8 ③-2、3
3	20XFA3400001	发动机进气管 Duct		1	①-5
3	30XFA3400001	发动机进气管 Duct		1	①-6、③-4
3	30V3400002	发动机进气管 Duct		1	②-2、4
3	30VBB3400001	发动机进气管 Duct		1	②-1、3
3	30XBB3400002	发动机进气管 Duct		1	①-1、③-1
3	30XSB3400001	发动机进气管 Duct		1	①-9
4	30V5107000	空滤器架 Bracket		1	
5	GB97.1	垫圈 Washer	8	2	
6	GB93	垫圈 Washer	8	2	

序号 Item No.	零件图号 Part No.	零部件名称 Part Description		数量 Q`ty	备注 Remark
		名称 Apellation	规格 Spec		
7	GB5783	螺母 Nut	M8×25	2	
8	30XDB3400001	空滤器进气管 Hose		1	①-2~4、6~8 ③-2~4
8	30XF1B3400001	空滤器进气管 Hose		1	①-5 ②-1、3
8	15XFB3400001	空滤器进气管 Hose		1	②-2、4
8	30XBB3400002	空滤器进气管 Hose		1	①-1、③-1
8	30XSB3400002	空滤器进气管 Hose		1	①-9
9	JB/ZQ3777-86	喉箍 Clip	55-70	1	①-2~4、6~8 ③-2~4
9	JB/ZQ3777-86	喉箍 Clip	55-70	2	①-1、5、9 ② ③-1

FORKLIFT PARTS CATALOGUE



散热装置

Radiator System

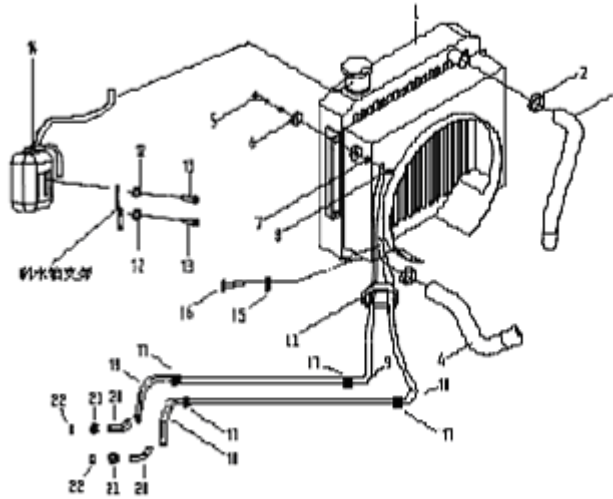

序号 Item No.	零件图号 Part No.	零部件名称 Part Description		数量 Q'ty	备注 Remark
		名称 Appellation	规格 Spec		
1	30XFA3310000	散热器总成 Radiator		1	①-2~4、6、9 ③-2~4
1	30XF1B3310000	散热器总成 Radiator		1	①-5
1	30WBB33D10000	散热器总成 Radiator		1	①-7、8
1	30V3310000	散热器总成 Radiator		1	②-2、4
1	30VBB3310000	散热器总成 Radiator		1	②-1
1	30UBB3310000	散热器总成 Radiator		1	②-3
1	30XBB3310000	散热器总成 Radiator		1	①-1 ③-1
2	JB/ZQ3777	喉箍 Clip, Hose	35-50	4	
3	30XDA3300001	上水管 Hose, Upper		1	①-2~4、7、8 ③-2、3
3	30X3300001	进水管 Hose, Upper		1	①-5
3	30XFA3300001	上水管 Hose, Upper		1	①-6、③-4
3	30V3300002	上水管 Hose, Upper		1	②-2、4
3	30VBB3300001	上水管 Hose, Upper		1	②-1、3
3	30XBB3300001	上水管 Hose, Upper		1	①-1 ③-1
3	20XSB3300001	上水管 Hose, Upper		1	①-9
4	30XDA3300003	下水管 Hose, Upper		1	①-2~4、7、8 ③-2、3
4	30X3300002	出水管 Hose, Lower		1	①-5
4	30XFA3300000	下水管 Hose, Lower		1	①-6、③-4

DALIAN FORKLIFT CO.,LTD.

序号 Item No.	零件图号 Part No.	零部件名称 Part Description		数量 Q'ty	备注 Remark
		名称 Apellation	规格 Spec		
4	30V3300001	下水管 Hose, Lower		1	②-2、4
4	30VBB3300002	下水管 Hose, Lower		1	②-1、3
4	30XBB3300002	下水管 Hose, Lower		1	①-1 ③-1
4	20XSB3300002	下水管 Hose, Lower		1	①-9
5	GB5783	螺栓 Bolt	M8×35	4	
6	30112-0002	橡胶垫 Cushion, Rubber		8	
7	GB97.1	垫圈 Washer	8	8	
8	GB6170	螺母 Nut	M8	4	
9	10I-Q/Q-1860/1900	进油管 Hose		1	①-2~4、9 ③-2、3
9	10I-Q/Q-1720/1750	进油管 Hose		1	①-5
9	10I-Q/Q-1840/1870	进油管 Hose		1	①-6、③-4
9	D10I-Q/Q-1330/1360	油管 Hose		1	②-1、2、4
9	HG/T3041	输油胶管 Hose	13×21×200	1	①-1 ③-1
10	30XDA3300004	胶管接头 Hose	8I-2100	1	①-2~6、9 ③
10	D10I-Q/Q-1220/1250	油管 Hose		1	②-1、2、4
10	HG/T3041	输油胶管 Hose	13×21×400		①-1 ③-1
11	ZD150×8	尼龙扎带 Band		5	
12	GB93	垫圈 Washer	6	2	
13	GB5781	螺栓 Bolt	M6×12	2	
14	H24C2-10201	副水箱 Water Tank		1	
15	JB982	垫圈 Washer	14	8	①-2~6、9 ②-1、2、4 ③-1~3
16	30X3300004	铰接螺栓 Bolt		4	①-2~6、9 ②-1、2、4 ③-1~3
17	JB/ZQ3777	喉箍 Clip, Hose	16~22	8	①-1 ③-1
18	40XBB332000	冷却油管 Cooling Pipe		1	①-1 ③-1
19	40XBB333000	冷却油管 Cooling Pipe		1	①-1 ③-1
20	L91428-00202	接管 Link		2	①-1 ③-1
21	F4202-14000	垫圈 Washer		4	①-1 ③-1
22	F4110-14000	带孔螺栓 Bolt		2	①-1 ③-1

FORKLIFT PARTS CATALOGUE



转向装置

Steering System

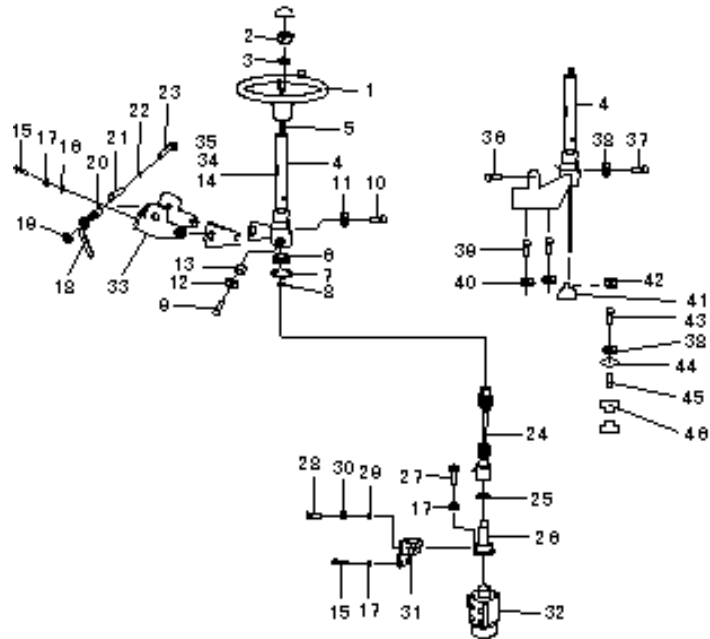

序号 Item No.	零件图号 Part No.	零部件名称 Part Description		数量 Q'ty	备注 Remark
		名称 Apellation	规格 Spec		
1	DC3CYC35-1000 0	方向盘总成	Handle Wheel	1	
2	GB6173	螺母	Nut	1	
3	GB93	垫圈	Washer	1	
4	DL3404012A	转向管柱总成	Column	1	
5	DL3404011A	转向轴	Shaft, Steering	1	
6	GB/T276-82	向心球轴承	Bearing	1	
7	GB893.1	挡圈	Ring, Snap	1	
8	J3401807	轴挡圈	Ring, Snap	1	
9	30V42B00001	支承栓	Bolt	2	
10	GB5781	螺栓	Bolt	1	
11	GB93	垫圈	Washer	1	
12	GB93	垫圈	Washer	2	
13	30X4200007	衬套	Bushing	2	
14	DL3404013A	喇叭线夹	Wire Clamp	1	
15	GB5783	螺栓	Bolt	8	

序号 Item No.	零件图号 Part No.	零部件名称 Part Description		数量 Q`ty	备注 Remark
		名称 Apellation	规格 Spec		
16	GB97.1	垫圈 Washer	10	4	
17	GB93	垫圈 Washer	10	12	
18	30V42B30000	锁紧手柄总成 Handle System		1	
19	GB6170	螺母 Nut	M14	1	
20	30V42B00002	锁紧柱 Lock Cylinder		1	
21	30V42B00003	钢管拔 Steel Tube	22×3.5-91	1	
22	GB97.1	垫圈 Washer	14	1	
23	30V42B00004	螺栓 Bolt		1	
24	DL3404020A	传动轴 Drive, Steering		1	
25	30V42B00008	防尘胶圈 Dust Proof Washer		1	
26	720-1106	转向轴总成 Shaft, Steering		1	
27	GB5782	螺栓 Bolt	M10×45	4	
28	GB5786	螺栓 Bolt	M12×1.25×25	2	
29	GB97.1	垫圈 Washer	12	2	
30	GB93	垫圈 Washer	12	2	
31	30V42B40000	转向器支架 Hydraulic Bracket		1	
32	532-1324	全液压转向器 Full Hydraulic Steering		1	
33	30V42B50000	支架总成 Bracket		1	
34	DJ3011A-4-A	复合插头 Plug		1	
35	30X4212100	喇叭按钮导线 Line		1	

FORKLIFT PARTS CATALOGUE



转向桥
Steering Axle

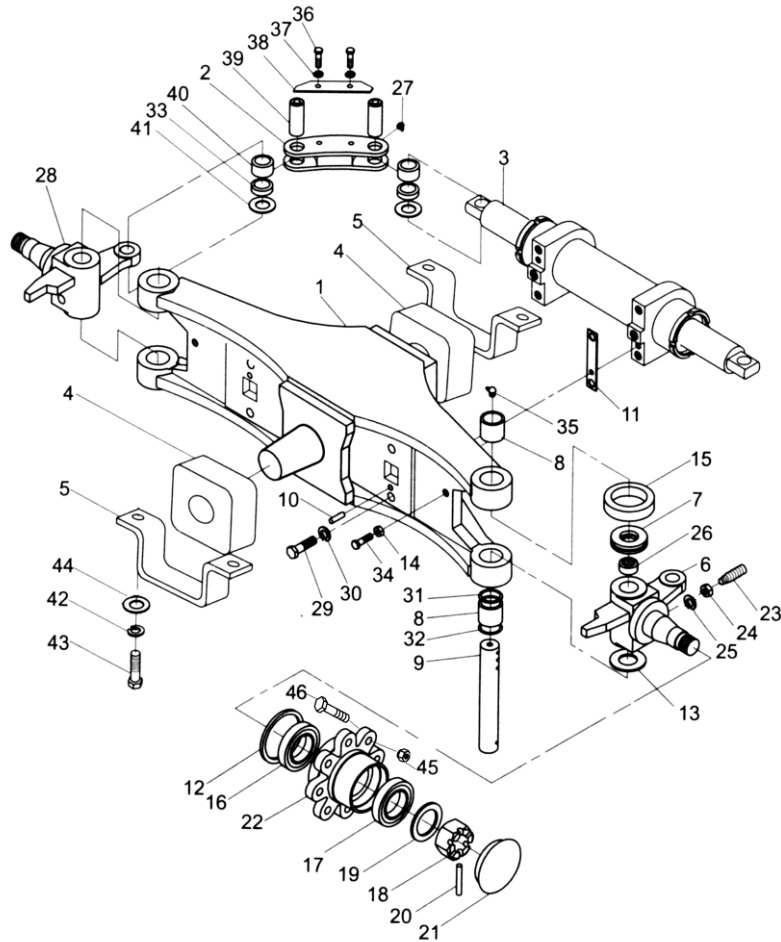

序号 Item No.	零件图号 Part No.	零部件名称 Part Description		数量 Q'ty	备注 Remark
		名称 Apellation	规格 Spec		
01	H24N4-30302C	桥体总成 Axle Ass'y		1	
02	A21B4-32081	连杆 Link		2	
03	H24C4-50402S	转向油缸总成 PowerCylinderAss'y		1	
04	H24N4-32541	减震块 Rubber		2	
05	30XDB0000001	托架 Bracket		2	
06	H24C4-32181	右转向节总成 Knuckle R.H.Ass'y		1	
07	Z-8208	单向推力轴承 (加防尘罩) Bearing		2	
08	Z-943/32	轴承 Bearing		4	
09	A21B4-32221	转向节主销 Pin,King		2	
10	B3120-10020	销 Pin		2	
11	A21B4-32251	调整垫 Shim		4	
12	Z6301-08524	橡胶油封 Seal,Oil		2	
13	22214-30321	转向节调整垫 Shim		2	

DALIAN FORKLIFT CO.,LTD.

序号 Item No.	零件图号 Part No.	零部件名称 Part Description		数量 Q'ty	备注 Remark
		名称 Apellation	规格 Spec		
14	B4313-00012	螺母 Nut	Nut	2	
15	A21B4-12002	防尘罩 Cap		2	
16	Z-32211	轴承 Bearing		2	
17	Z-32207	轴承 Bearing		2	
18	A21B4-32311	螺母 Nut		2	
19	B5310-00030	垫圈 Washer		2	
20	B3010-6P360	销 Pin		2	
21	A21B4-32231	轮毂盖 Cap		2	
22	A21B4-32241	轮毂 Hub		2	
23	G27Z4-32011	紧定螺钉 Pin		2	
24	B4313-00012	螺母 Nut		2	
25	B5050-00012	垫圈 Washer	12	2	
26	A21B4-12001	衬套 Bushing		2	
27	Q700B06	直通式滑脂嘴 Fitting Grease		4	
28	H24C4-32171	左转向节总成 Knuckle L.H. Ass'y		1	
29	B0330-14040	螺栓 Bolt		4	
30	B5050-00014	垫圈 Washer		4	
31	23654-32161	O形圈 O-Ring		2	
32	23654-32081	油封 Seal,Oil		4	
33	H24C4-12003	衬套 Bushing		4	
34	B0330-12030	螺栓 Bolt		2	
35	Q701B90	弯颈式滑脂嘴 Fitting Grease		4	
36	B0110-08016	螺栓 Bolt		4	
37	B5050-00008	垫圈 Washer	8	4	
38	A21B4-32300	挡板 Baffle		2	
39	A21B4-32261A	连杆销 Pin		4	
40	H24C4-32061	ES型向心关节轴承 Bearing		4	
41	A21B4-32281	调整垫 Shim		4	
42	GB93	垫圈 Spring Washer	16	4	
43	GB5786	螺栓 Bolt	M16×1.5×35	4	
44	GB97.1	垫圈 Washer	16	4	
45	23654-32041	轮毂螺栓 Bolt, Hub		16	
46	30X4100005	轮毂螺母 Nut, Hub		16	

FORKLIFT PARTS CATALOGUE



转向油缸
Steering Cylinder

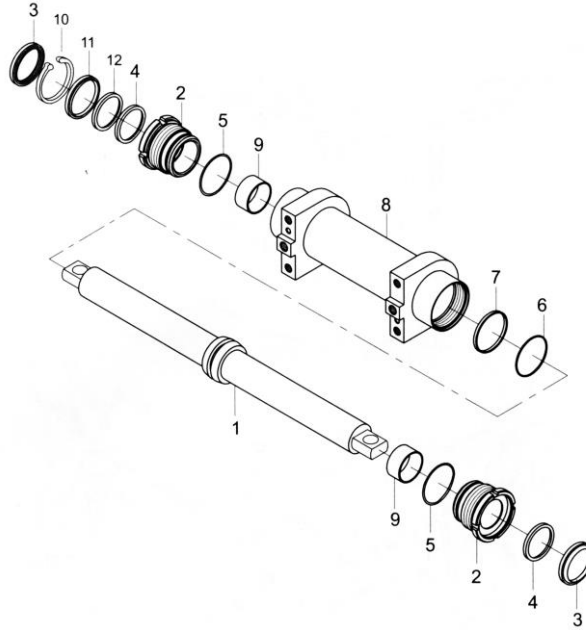

序号 Item No.	零件图号 Part No.	零部件名称 Part Description		数量 Q'ty	备注 Remark
		名称 Apellation	规格 Spec		
1	H24C4-52113	活塞杆总成 Piston rod ass'y		1	
2	H24C4-52103	缸盖 Cap		2	
3	24329-45581	防尘圈 Seal, dust		2	
4	Z6162-05008	U密封圈 U-ring	50×60×8	2	
5	GB3452.1-92	O 形圈 O-ring	63×3.55	2	
6	GB3452.1-92	O 形圈 O-ring	63×3.55	1	
7	H24C4-52171	支承环 Seal,slipper		1	
8	H24C4-52142	缸筒总成 Body,power steering		1	
9	23460-53171	钢背轴承 Bearing	5030	2	
10	GB893.1-86	挡圈 Snap ring	72	2	
11	H24C4-53101	挡环 Ring		2	
12	22658-52301	挡片 Snap shim	50×60×3	2	



转向车轮

Steering Wheel

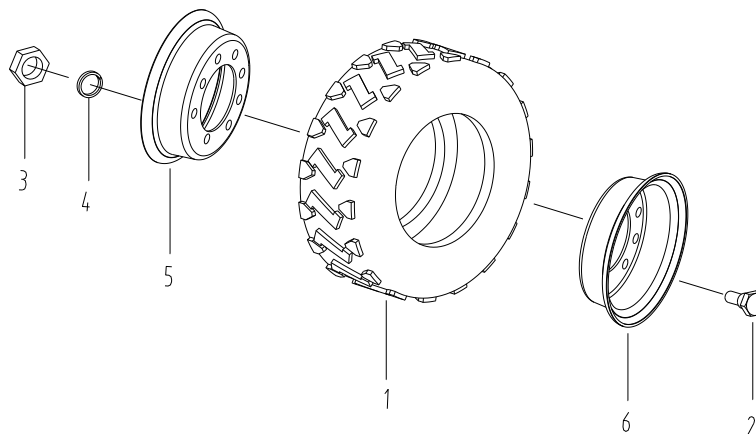

序号 Item No.	零件图号 Part No.	零部件名称 Part Description		数量 Q`ty	备注 Remark
		名称 Apellation	规格 Spec		
1	6.5-10-10PR	轮胎 Tire		2	①②
1	6.5-10-12PR	轮胎 Tire		2	③
2	L91239-03300	螺栓 Bolt		16	
3	GB6171	螺母 Nut	M12×1.25	16	
4	GB93	垫圈 Washer	12	16	
5	30X4500002	后轮辋 (内) Rear rim, inside		2	
6	30X4500001	后轮辋 (外) Rear rim, inside		2	

FORKLIFT PARTS CATALOGUE



车架与平衡重

Frame and Counter Weight

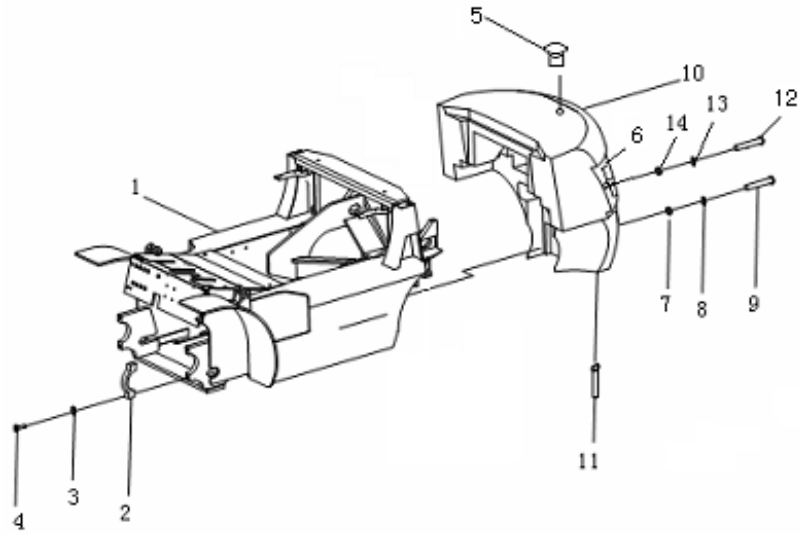

序号 Item No.	零件图号 Part No.	零部件名称 Part Description		数量 Q'ty	备注 Remark
		名称 Apellation	规格 Spec		
1	30XBB5100000	车架 Frame		1	①-1 ③-1
1	30XDB51D00000	车架 Frame		1	①-2~4、7、8 ③-2、3
1	30XF1B51D00000	车架 Frame		1	①-5
1	30XRB5100000	车架 Frame		1	①-6、③-4
1	30VFB51D00000	车架 Frame		1	②-2
1	30ZFB51D00000	车架 Frame		1	②-4
1	30VBB5100000	车架 Frame		1	②-1、3
1	30XSB5100000	车架 Frame		1	①-9
2	30X1000014	支座盖 Cap		2	
3	GB93	垫圈 Washer		4	
4	GB5785	螺栓 Bolt	M16×15×65	4	
5	20XDB5900004	封盖 Close over		2	
6	30XDB5900002	栅板 Board, Grid		1	
7	30V0000001	垫圈 Washer		2	
8	GB93	垫圈 Washer	30	2	
9	GB5782	螺栓 Bolt	M30×180	2	
10	30XDB5900001	平衡重 Counter weight		1	①②
10	35XCB5900001	平衡重 Counter weight		1	③
11	30X5800000	牵引栓 Pin, draw		1	
12	GB5783	螺栓 Bolt	M10×20	2	
13	GB93	垫圈 Washer	10	2	
14	GB97.1	垫圈 Washer	10	2	



仪表架及机罩安装

Instrument Panel and Hood

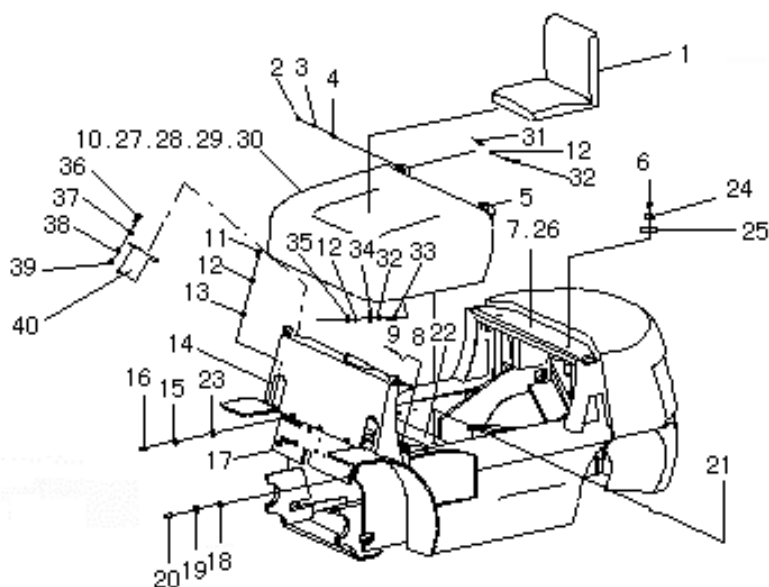

序号 Item No.	零件图号 Part No.	零部件名称 Part Description		数量 Q`ty	备注 Remark
		名称 Apellation	规格 Spec		
1	D91314-03020	座椅 Seat		1	
2	L91212-01600	衬套 Bushing		4	
3	F2841-20020	销 Pin		2	
4	L91213-14300	销轴 Pin axis		2	
5	L91313-25900	铰链 Hinge		2	
6	JB3717.22	五角星形把手 Bolt cap	M8×40×25	2	
7	30XDB53D40001	水箱盖板 Plate, water tank		1	
8	30XDB5200002	踏板 Floor board		1	①-1~6、9 ②-1、2、4 ③
8	30WBB52D00002	踏板 Floor board		1	①-7、8
8	30UBB5210001	踏板 Floor board		1	②-3
9	30XDB52D00003	橡胶垫 Rubber mat		1	①-1~6、9 ②-1、2、4③

FORKLIFT PARTS CATALOGUE

9	30WBB52D00003	橡胶垫 Rubber mat		1	①-7、8、 ②-3
序号 Item No.	零件图号 Part No.	零部件名称 Part Description		数量 Q'ty	备注 Remark
		名称 Apellation	规格 Spec		
10	L91210-37062	发动机罩总成 Hood		1	
11	GB5783	螺栓 Bolt	M10×25	4	
12	GB93	垫圈 Washer	10	9	
13	GB96.1	垫圈 Washer	10	4	
14	30XDB52D10000	仪表架 Panel		1	
15	GB93	垫圈 Washer	8	3	
16	GB5783	螺栓 Bolt	M8×20	3	
17	30XDB5200001	前板 Plate, front		1	
18	GB97.1	垫圈 Washer	12	4	
19	GB93	垫圈 Washer	12	4	
20	GB5783	螺栓 Bolt	M12×30 Bolt	4	
21	30X5200002	螺钉 Screw		2	
22	30XDB53D20000	后底板总成 Board		1	①-1~6、9 ②-1、2、4 ③
22	30WBB53D20000	后底板总成 Board		1	①-7、8 ②-3
23	30XDB5200004	垫圈 Washer		3	
24	L92512-05300	隔套 Cover		2	
25	Q/DC.J.056102	胶环 Ring	14×2	2	
26	L91410-02300	密封条 Dust bar	L=1350	1	
27	QD16	气弹簧 Shore	350×205×430	1	
28	GB882	销轴 Pin axis	8×70	2	
29	GB91	销 Pin	2×16	2	
30	GB97.1	垫圈 Washer	8	2	

序号 Item No.	零件图号 Part No.	零部件名称 Part Description		数量 Q`ty	备注 Remark
		名称 Apellation	规格 Spec		
31	GB5786	螺栓 Bolt	M10×1.25×16	4	
32	GB97.1	垫圈 Washer	10	5	
33	GB5786	螺栓 Bolt	M10×1.25×45	1	
34	L91213-13700	挂扣 Buckle		1	
35	GB6171	螺母 Nut	M10×1.25	1	
36	GB67	螺钉 Bolt	M5×20	2	
37	GB97.1	垫圈 Washer	5	2	
38	GB93	垫圈 Washer	5	2	
39	GB6170	螺母	M5	2	
40	H24C6-42072	工具箱 Box		1	

FORKLIFT PARTS CATALOGUE



燃油箱安装

Fuel System

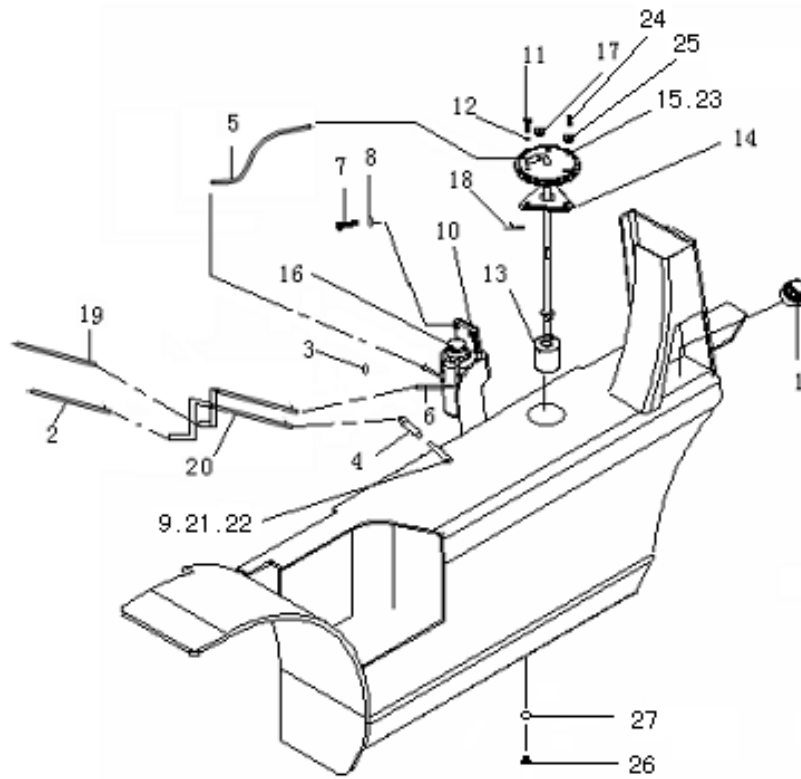

序号 Item No.	零件图号 Part No.	零部件名称 Part Description		数量 Q'ty	备注 Remark
		名称 Apellation	规格 Spec		
1	L91364-10600	油盖总成 Cap		1	①③
2	HG/T3041	输油胶管 Hose	8×15×400	1	①③
3	JB/ZQ3777	喉箍 Clamp	11~16	10	①③
4	HG/T3041	输油胶管 Hose	8×15×220	1	①③
5	HG/T3041	输油胶管 Hose	8×15×250	1	①③
6	HG/T3041	输油胶管 Hose	8×15×320	1	①③
7	GB5783	螺栓 Bolt	M8×16	4	①③
8	GB93	垫圈 Washer	8	4	①③
9	20XDB5420000	燃油管 Fuel Hose	Fuel Hose	1	①-2~8 ③-2~4
9	20XSB5410000	燃油管 Fuel Hose	Fuel Hose	1	①-9
10	20XDB5400001	支架 Bracket	Bracket	1	①-2~8 ③-2~

DALIAN FORKLIFT CO.,LTD.

序号 Item No.	零件图号 Part No.	零部件名称 Part Description		数量 Q`ty	备注 Remark
		名称 Apellation	规格 Spec		
					4
11	L91276-00500	螺栓 Bolt		3	①-2~9 ③-2~ 4
12	JB982	垫圈 Washer	8	3	①-2~9 ③-2~ 4
13	Y0606-0000	滤清器 Filter		1	①-2~9 ③-2~ 4
14	20XDB5412000	压板 Board		1	①-2~9 ③-2~ 4
15	30XDB54D11000	顶盖总成 Cap		1	①-2~9 ③-2~ 4
16	8-94154754-4	油水分离器 Fuel Filter		1	①-2~8 ③-2~ 4
17	L91364-01300	隔套 Spacer		3	①-2~9 ③-2~ 4
18	GB91	销 Pin	2×16	3	①-2~9 ③-2~ 4
19	HG/T3041	输油胶管 Hose	8×15×200	1	①-2~8 ③-2~ 4
20	30XDB5410000	发动机进回油管总成 Hose	Hose	1	①-2~8 ③-2~ 4
21	JB982	垫圈 Washer	12	2	①-2~8 ③-2~ 4
22	L91264-06900	回油管 Vitta, Return		1	①-2~9 ③-2~ 4
23	L93175-12600	垫片 Packing		1	①-2~9 ③-2~ 4
24	20XDB5410001	轴 Shaft		1	①-2~9 ③-2~ 4
25	20XDB5410002	轴套 Spacer		1	①-2~9 ③-2~ 4
26	100X5100002	螺塞 Plug		1	①-2~9 ③-2~ 4
27	100X5100003	垫 Washer		1	①-2~9 ③-2~ 4

FORKLIFT PARTS CATALOGUE

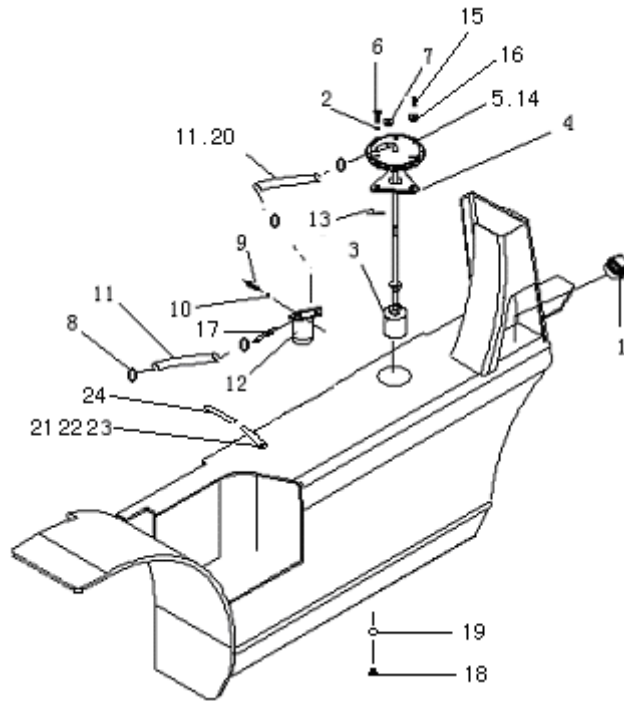

序号 Item No.	零件图号 Part No.	零部件名称 Part Description		数量 Q'ty	备注 Remark
		名称 Apellation	规格 Spec		
1	L91364-10600	油盖总成 Cap		1	②
2	JB982	垫圈 Washer	8	3	②
3	Y0606-0000	滤清器 Filter		1	②
4	20XDB5412000	压板 Board		1	②
5	30XDB54D11000	顶盖总成 Cap		1	②
6	L91276-00500	螺栓 Bolt		3	②
7	L91364-01300	隔套 Spacer		3	②
8	JB/ZQ3777	喉箍 Clamp	11~16	4	②
9	GB5783	螺栓 Bolt	M8×20	2	②
10	GB93	垫圈 Washer	8	2	②
11	HG/T3041	输油胶管 Hose	8×15×400	2	②-2、4

DALIAN FORKLIFT CO.,LTD.

11	HG/T3041	输油胶管 Hose	8×15×400	1	②-1、3
12	282A16	汽油滤清器 Filter		1	②

序号 Item No.	零件图号 Part No.	零部件名称 Part Description		数量 Q`ty	备注 Remark
		名称 Apellation	规格 Spec		
13	GB91	销 Pin	2×16	3	②
14	L93175-12600	垫片 Packing		1	②
15	20XDB5400001	轴 Shaft		1	②
16	20XDB5400002	轴套 Spacer		1	②
17	30V5400001	接头 Joint		2	②-2、4
17	30V5400001	接头 Joint		1	②-1、3
17	30VBB5400001	接头 Joint		1	②-1、3
18	100X5100002	螺塞 Plug		1	②
19	100X5100003	垫 Washer		1	②
20	HG/T3041	输油胶管 Hose	6×13×800	1	②-1、3
21	JB982	垫圈 Washer	12	2	②-1、3
22	L91264-06900	回油管 Vitta, Return		1	②-1、3
23	20XDB5420000	燃油管 Fuel Hose		1	②-1、3
24	HG/T3041	输油胶管 Hose	6×13×200	1	②-1、3

FORKLIFT PARTS CATALOGUE

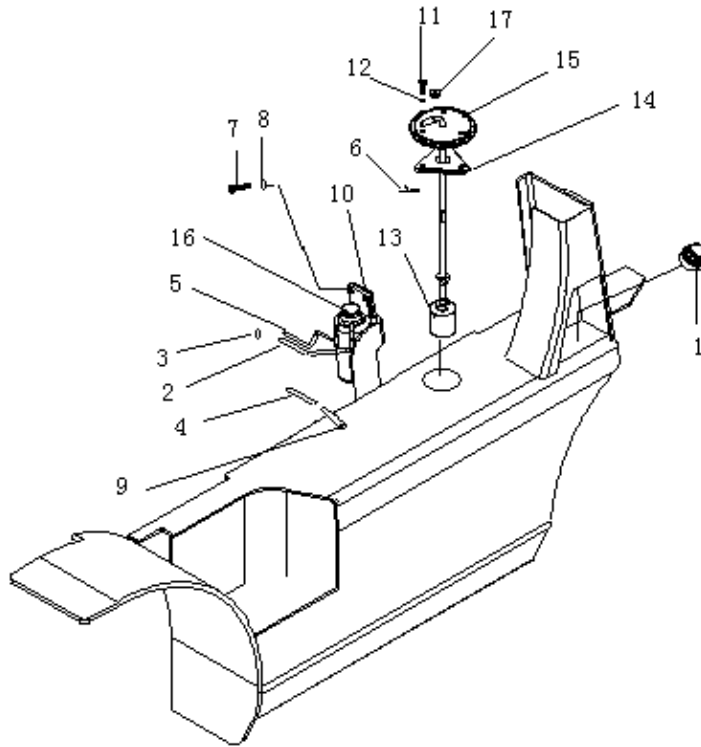

序号 Item No.	零件图号 Part No.	零部件名称 Part Description		数量 Q'ty	备注 Remark
		名称 Appellation	规格 Spec		
01	L91364-10600	油盖总成 Cap		1	①-1 ③-1
02	HG/T3041	输油胶管 Hose	8×15×800	1	①-1 ③-1
03	JB/ZQ3777	喉箍 Clamp	11~16	10	①-1 ③-1
04	HG/T3041	输油胶管 Hose	6×16×700	1	①-1 ③-1
05	HG/T3041	输油胶管 Hose	8×15×200	1	①-1 ③-1
06	GB91	销 Pin	2×16	3	①-1 ③-1
07	GB5783	螺栓 Bolt	M8×16	4	①-1 ③-1
08	GB93	垫圈 Washer	8	4	①-1 ③-1
09	20XDB5420000	燃油管 Fuel Hose		1	①-1 ③-1
	JB982	垫圈 Washer	12	2	①-1 ③-1
	L91264-06900	回油管 Vitta, Return		1	①-1 ③-1
10	40XBB5400001	支架 Bracket		1	①-1 ③-1
11	L91276-00500	螺栓 Bolt		3	①-1 ③-1
12	JB982	垫圈 Washer	8	3	①-1 ③-1
13	Y0606-0000	滤清器 Filter		1	①-1 ③-1
14	20XDB5412000	压板 Board		1	①-1 ③-1

DALIAN FORKLIFT CO.,LTD.

15	30XDB54D11000	顶盖总成 Cap	1	①-1 ③-1
	L93175-12600	垫片 Packing	1	①-1 ③-1
16	8-94154754-4	油水分离器 Fuel Filter	1	①-1 ③-1
17	L91364-01300	隔套 Spacer	3	①-1 ③-1



工作油箱

Hydraulic Oil Tank

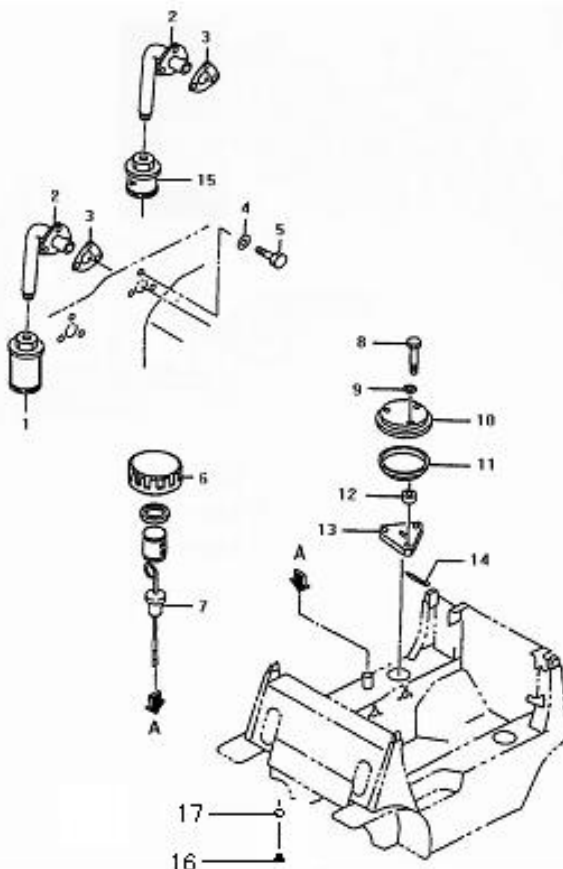

序号 Item No.	零件图号 Part No.	零部件名称 Part Description		数量 Q`ty	备注 Remark
		名称 Apellation	规格 Spec		
1	20XDB5600001	回油滤油器总成 Suction		1	
2	L91375-20300	吸油管 Pipe		2	
3	L91875-00400	垫片 Packing		2	
4	JB982	垫圈 Sealing	10	6	
5	GB5786	螺栓 Bolt	M10×1.25×16	6	

FORKLIFT PARTS CATALOGUE

6	L91275-30010D	油盖总成 Cap		1	
7	L91375-06100	工作油标尺 Gage		1	

序号 Item No.	零件图号 Part No.	零部件名称 Part Description		数量 Q`ty	备注 Remark
		名称 Apellation	规格 Spec		
8	L91276-00500	螺栓 Bolt		3	
9	JB982	垫圈 Sealing	8	3	
10	L91375-10100	油箱盖 Cover		1	
11	L91375-12600	垫片 Packing		1	
12	L91364-01300	隔套 Spacer		3	
13	L91376-10202	压板 Clamp		1	
14	GB91	销 Pin	2×15	3	
15	20XDB5600002	过滤器 Strainer		1	
16	100X5100002	螺塞 Plug		1	
17	100X5100003	垫 Washer		1	



蓄电池安装

Installation of The Battery

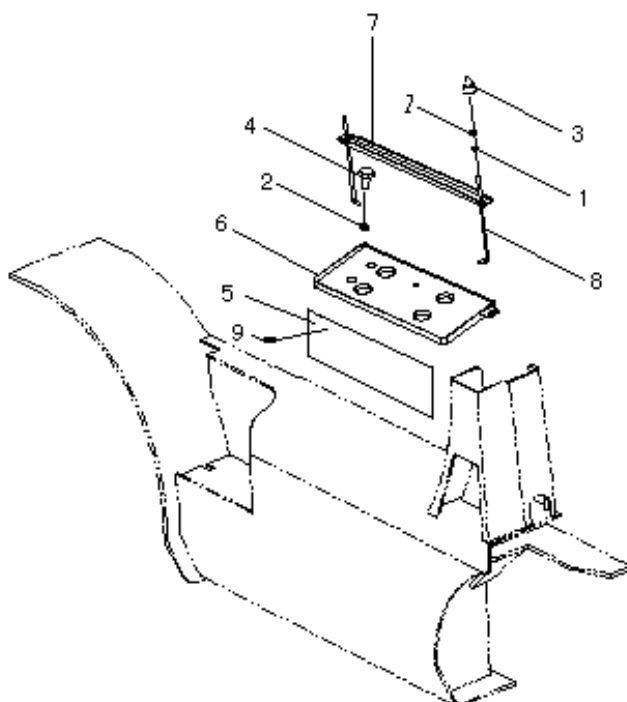

序号 Item No.	零件图号 Part No.	零部件名称 Part Description		数量 Q`ty	备注 Remark
		名称 Apellation	规格 Spec		
1	GB97.1	垫圈 Washer	8	2	
2	GB93	垫圈 Washer	8	4	
3	GB6170	螺母 Nut	M8	2	
4	GB5783	螺栓 Bolt	M8×10	2	
5	20XDB5700001	隔热板 Board		1	
6	20XDB5710000	电瓶座 Seat, battery		1	
7	D91206-05900	蓄电池固定夹 Plate		1	

FORKLIFT PARTS CATALOGUE

8	D91304-01200	蓄电池固定杆 Hook		2	
9	GB12618	抽芯铆钉 Rivet	3×7	3	



行车制动与微动操纵
Brake and inching Control

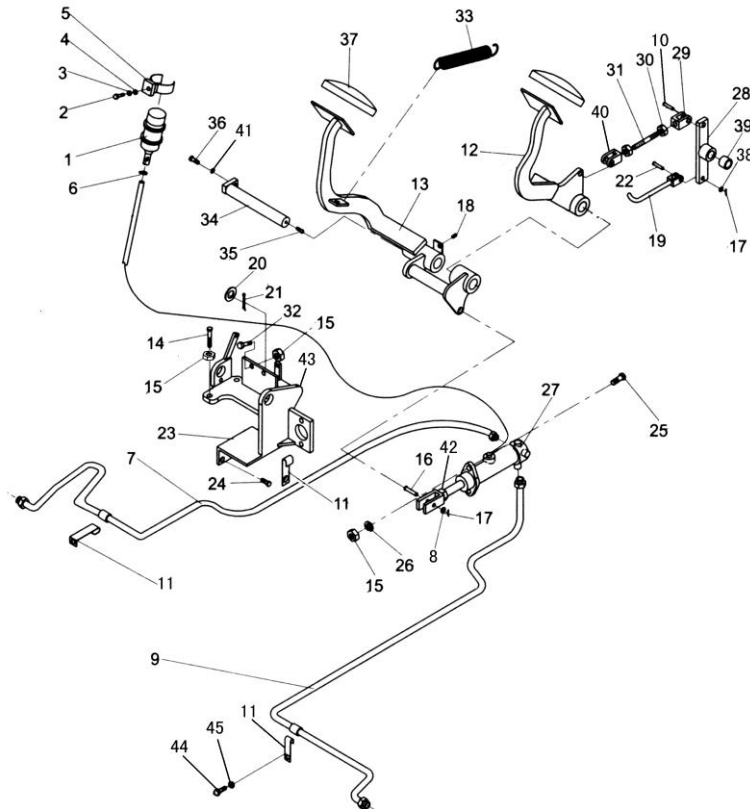

序号 Item No.	零件图号 Part No.	零部件名称 Part Description		数量 Q`ty	备注 Remark
		名称 Apellation	规格 Spec		
1	N0030-3500020	方油杯 Tank, reserve		1	①-1~5、9 ③ ②-1、2、4
2	30XDB6100001	油杯接头 Cup, tie-in		1	①-1~5、9 ③ ②-1、2、4
3	JB982	垫圈 Washer	18	1	①-1~5、9 ③ ②-1、2、4
4	GB1235	O形密封圈 O-Ring	35×3.1	1	①-1~5、9 ③ ②-1、2、4
5	Q/DC.J.05611	管夹 Clip	38	1	①-1~5、9 ③ ②-1、2、4
6	N0030-3500017	油杯盖 Cup, cap		1	①-1~5、9 ③ ②-1、2、4
7	30V6180000	油管总成(右) Hose R.H.		1	①-1~5、9 ③ ②-1、2、4

DALIAN FORKLIFT CO.,LTD.

8	GB97.1	垫圈 Washer	10	2	①-1~5、9③ ②-1、2、4
9	30V6180000	油管总成(左) Hose L.H.		1	①-1~5、9③ ②-1、2、4
10	GB91	销 Pin	3.2×20	2	①-1~5、9③ ②-1、2、4
序号 Item No.	零件图号 Part No.	零部件名称 Part Description		数量 Q`ty	备注 Remark
		名称 Apellation	规格 Spec		
11	30V6100010	管夹 Clip		1	①-1~6、9③ ②-1、2、4
12	30V6170000	微动踏板 Clutch pedal		1	①-1~6、9③ ②-1、2、4
13	30X6140000	制动踏板 Brake pedal		1	①-1~6、9③ ②-1、2、4
14	GB5782	螺栓 Bolt	M10×40	1	①-1~6、9③ ②-1、2、4
15	GB6170	螺母 Nut	M10	3	①-1~6、9③ ②-1、2、4
16	GB882	销轴 Pin,clevis	B10×30	2	①-1~6、9③ ②-1、2、4
17	GB91	销 Pin	3.2×16	2	①-1~6、9③ ②-1、2、4
18	46584 S0100	挡块 Stopper		1	①-1~6、9③ ②-1、2、4
19	30X6120000	接头体 Link		1	①-1~6、9③ ②-1、2、4
20	GB97.1	垫圈 Washer	16	1	①-1~6、9③ ②-1、2、4
21	GB91	销 Pin	4×30	1	①-1~6、9③ ②-1、2、4
22	GB882	销轴 Pin,clevis	B8×30	1	①-1~6、9③ ②-1、2、4
23	30V6110000	支架 Bracket		1	①-1~6、9③ ②-1、2、4
24	GB5783	螺栓 Bolt	M10×20	4	①-1~6、9③ ②-1、2、4
25	GB5782	螺栓 Bolt	M10×35	2	①-1~6、9③ ②-1、2、4
26	GB93	垫圈 Washer	10	6	①-1~6、9③ ②-1、2、4
27	CKM3/4	制动总泵 Master cylinder		1	①-1~6、9③ ②-1、2、4
28	30X6110000	连板组件 Linker		1	①-1~6、9③ ②-1、2、4
29	30X6100005	左接头 Joint L.H.		1	①-1~6、9③ ②-1、2、4
30	30X6100006	左螺母 Nut L.H.		1	①-1~6、9③ ②-1、2、4
31	30X6100004	调节螺杆 Rod		1	①-1~6、9③ ②-1、2、4
32	GB5786	螺栓 Bolt	M10×1.25×30	1	①-1~6、9③ ②-1、2、4
33	30X6100003	弹簧 Spring		2	①-1~6、9③ ②-1、2、4

FORKLIFT PARTS CATALOGUE

34	30X6150000	踏板轴 Shaft		1	①-1~6、9 ③ ②-1、2、4
35	JB/T7940.1	油杯 Fitting,grease	M10×1	1	①-1~6、9 ③ ②-1、2、4
36	GB5783	螺栓 Bolt	M8×16	1	①-1~6、9 ③ ②-1、2、4

序号 Item No.	零件图号 Part No.	零部件名称 Part Description		数量 Q'ty	备注 Remark
		名称 Appellation	规格 Spec		
37	30X6100001	盖 Cap		2	①-1~6、9 ③ ②-1、2、4
38	GB97.1	垫圈 Washer	8	2	①-1~6、9 ③ ②-1、2、4
39	1615	衬套 Bushing		2	①-1~6、9 ③ ②-1、2、4
40	30X610002	接头 Joint		1	①-1~6、9 ③ ②-1、2、4
41	GB93	垫圈 Washer	8	1	①-1~6、9 ③ ②-1、2、4
42	GB6171	螺母 Nut	M10×1.25	2	①-1~6、9 ③ ②-1、2、4
43	15XFB6110000	托座 Seating		1	①-1~6、9 ③ ②-1、2、4
44	GB5781	螺栓 Bolt	M6×20	1	①-1~6、9 ③ ②-1、2、4
45	GB93	垫圈 Washer	6	1	①-1~6、9 ③ ②-1、2、4



制动离合操纵

Clutch & Brake Pedal

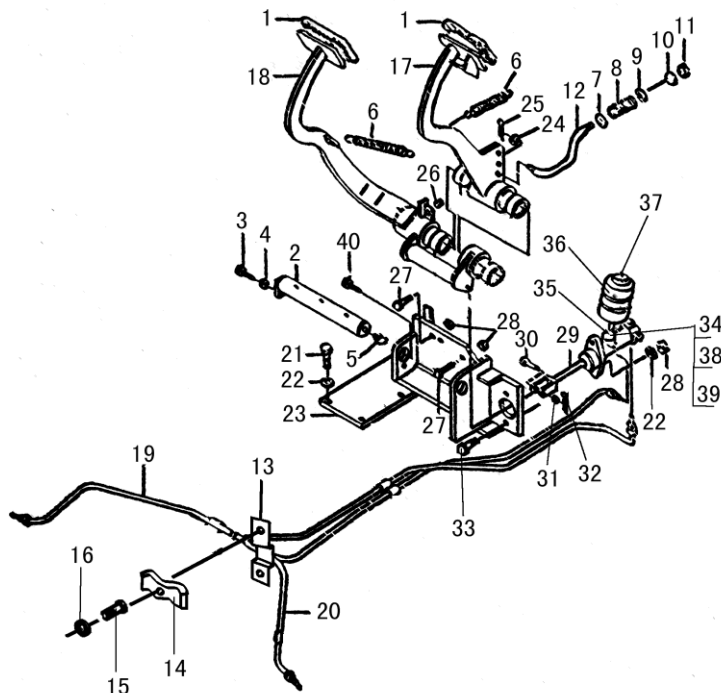

序号 Item No.	零件图号 Part No.	零部件名称 Part Description		数量 Q'ty	备注 Remark
		名称 Apellation	规格 Spec		
1	30X6100001	盖 Cover		2	①-7、8、②-3
2	30X6150000	踏板轴 Shaft, Pedal		1	①-7、8、②-3
3	GB5783	螺栓 Bolt	M8×16	1	①-7、8、②-3
4	GB93	垫圈 Washer	8	1	①-7、8、②-3
5	JB/T7940.2	油杯 45°Fitting, Grease	M10×1	1	①-7、8、②-3
6	30X6100003	弹簧 Spring		2	①-7、8、②-3
7	30W6100001	垫圈 Washer		2	①-7、8、②-3
8	30W6100002	弹簧 Spring		1	①-7、8、②-3

FORKLIFT PARTS CATALOGUE

9	GB97.1	垫圈 Washer	12	1	①-7、8、②-3
10	30W6100003	接头 Joint		1	①-7、8、②-3
11	GB6173	螺母 Bolt	M12×1.25	1	①-7、8、②-3
12	30W6140000	拉杆总成 Rod Ass'y		1	①-7、8、②-3
序号 Item No.	零件图号 Part No.	零部件名称 Part Description		数量 Q'ty	备注 Remark
		名称 Apellation	规格 Spec		
13	30V6110000	支架 Bracket		1	①-7、8、②-3
14	30V6100010	管夹 Clip		1	①-7、8、②-3
15	GB5781	螺栓 Bolt	M6×20	1	①-7、8、②-3
16	GB93	垫圈 Washer	6	1	①-7、8、②-3
17	30W6110000	离合踏板 Clutch Pedal		1	①-7、8、②-3
18	30W6120000	制动踏板 Brake Pedal		1	①-7、8、②-3
19	30V6180000	油管总成 (右) Pipe R.H.Brake		1	①-7、8、②-3
20	30V6130000	油管总成 (左) Pipe L.H.Brake		1	①-7、8、②-3
21	GB5781	螺栓 Bolt	M10×25	5	①-7、8、②-3
22	GB859	垫圈 Washer	10	7	①-7、8、②-3
23	15WAB6140000	踏板支座 Bracket, Pedal		1	①-7、8、②-3
24	GB97.1	垫圈 Washer	10	1	①-7、8、②-3
25	GB91	销 Pin	3.2×25	1	①-7、8、②-3
26	46584 S0100	挡块 Stopper		1	①-7、8、②-3
27	GB5786	螺栓 Bolt	M10×1.25×30	2	①-7、8、②-3
28	GB6171	螺母 Nut	M10×1.25	5	①-7、8、②-3
29	CKM3/4	制动总泵 Master Cylinder		1	①-7、8、②-3
30	GB882	销轴 Pin, Clevis	B8×26	1	①-7、8、②-3
31	GB97.1	垫圈 Washer	8	1	①-7、8、②-3
32	GB91	销 Pin	3.2×16	1	①-7、8、②-3
33	GB5786	螺栓 Bolt	M10×1.25×35	2	①-7、8、②-3
34	30XDB6100001	油杯接头 Joint		1	①-7、8、②-3
35	Q/DCJ.05611-2002	管夹 Clip	38	1	①-7、8、②-3
36	N0030-3500020	方油杯 Fitting, Grease		1	①-7、8、②-3

DALIAN FORKLIFT CO.,LTD.

37	N0030-3500017	油杯盖 Cup, Cover		1	①-7、8、②-3
38	GB1235	O形密封圈 O-Ring	35×3.1	1	①-7、8、②-3
39	JB982	垫圈 Washer	18	1	①-7、8、②-3
40	GB5786	螺栓 Bushing	M10×1.25×55	1	①-7、8、②-3



手制动操纵
Hand Brake System

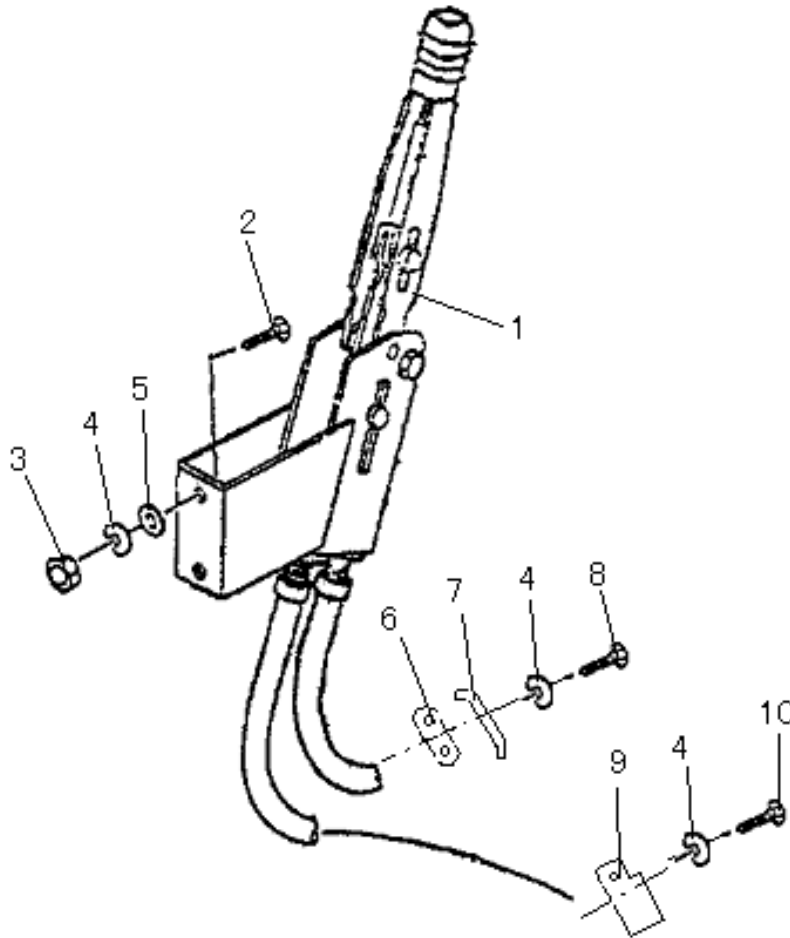

序号 Item No.	零件图号 Part No.	零部件名称 Part Description		数量 Q`ty	备注 Remark
		名称 Apellation	规格 Spec		
1	30X62A00000	手制动器 Lever Brake		1	
2	GB5783	螺栓	M10×45	2	

FORKLIFT PARTS CATALOGUE

3	GB6170	螺母 Nut	M10	2	
4	GB93	垫圈 Washer	10	2	
5	GB97.1	垫圈 Washer	10	2	



油门操纵

Accelerator Pedal

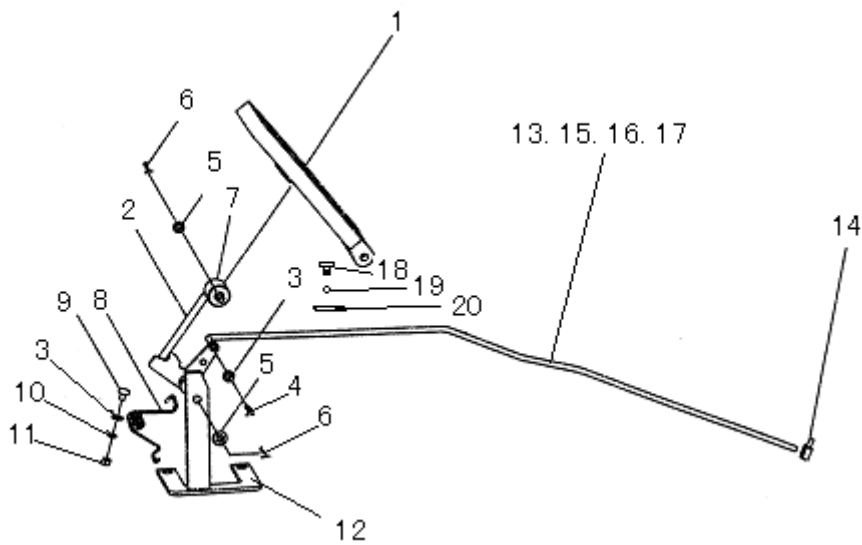

序号 Item No.	零件图号 Part No.	零部件名称 Part Description		数量 Q`ty	备注 Remark
		名称 Apellation	规格 Spec		
1	H24C5-60201	油门踏板总成 Pedal		1	①-1~ 8②③
2	30XDB6420000	摇臂总成 Link		1	①-1~8③
2	30VFB6420000	摇臂总成 Link		1	②
3	GB97.1	垫圈 Washer	6	4	①-1~ 8②③
4	GB91	销 Pin	2×10	2	①-1~8③
5	GB97.1	垫圈 Washer	8	2	①-1~8③
5	GB97.1	垫圈 Washer	10	1	②
6	GB91	销 Pin	2×12	2	①-1~8③

DALIAN FORKLIFT CO.,LTD.

6	GB91	销 Pin	2×12	3	②
7	30XDB6400001	尼龙滚子 Roll		1	①-1~ 8②③
8	30X6400001	弹簧 Spring		1	①-1~ 8②③
9	GB5783	螺栓 Screw	M6×16	2	①-1~ 8②③
10	GB93	垫圈 Washer	6	2	①-1~ 8②③
序号 Item No.	零件图号 Part No.	零部件名称 Part Description		数量 Q`ty	备注 Remark
		名称 Apellation	规格 Spec		
11	GB6170	螺母 Nut	M6	4	①-1~ 8②③
12	30XDB6410000	支架 Bracket		1	①-1~6、③
12	30WBB6410000	支架 Bracket		1	①-7、8
12	30X6410000	托架 Bracket		1	②
13	30XDB6400002A	油门拉杆 Shank		1	①-1~3、 ③-2、3
13	30XEB6400001	油门拉杆 Shank		1	①-4
13	30WBB6400001	油门拉杆 Shank		1	①-7、8
13	30X64A00002	前拉杆 Shank		1	①-5
13	30XFB6400002A	油门拉杆 Shank		1	①-6、③-4
13	30V6440000	油门拉线 Shank		1	②
14	30X64A00007	连接块 Block		1	①③
15	30X64A00004	块 Block		1	①-5
16	30X64A00000	传动杆 Shank		1	①-5
17	30X64A00006	后拉杆 Shank		1	①-5
18	GB5781	螺栓	M8×16	2	②
19	GB97.1	垫圈 Washer	8	2	②
20	GB882	销轴 Pin	B6×14	1	②

FORKLIFT PARTS CATALOGUE

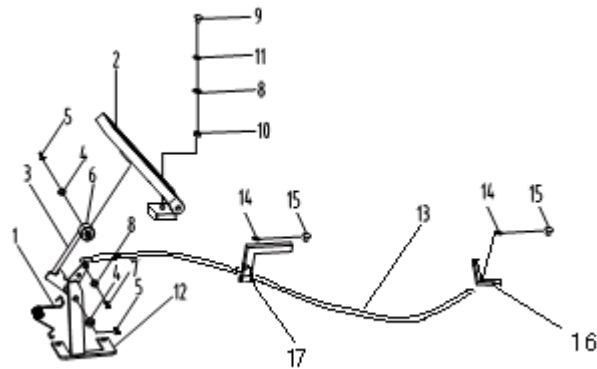

序号 Item No.	零件图号 Part No.	零部件名称 Part Description		数量 Q'ty	备注 Remark
01	30X6400001	弹簧	Spring	1	①-9
02	H24C5-60201	油门踏板总成	Pedal	1	①-9
03	30XDB6420000	摇臂总成	Link	1	①-9
04	GB97.1	垫圈 8	Washer	2	①-9
05	GB91	销 2×12	Pin	4	①-9
06	30XDB6400001	尼龙滚子	Roll	1	①-9
07	GB882	销 6×30	Pin	2	①-9
08	GB97.1	垫圈 6	Washer	2	①-9
09	GB5783	螺栓 M6×16	Bolt	4	①-9
10	GB6170	螺母 M6	Nut	2	①-9
11	GB93	垫圈 6	Washer	4	①-9
12	30XDB6410000	支架	Bracket	1	①-9
13	40XBB6400001	油门拉线总成	Shank	1	①-9
14	GB93	垫圈 8	Washer	4	①-9

DALIAN FORKLIFT CO.,LTD.

15	GB5783	螺栓 M8×20	Bolt	4	①-9
16	40XFB6400001	油门拉线支架	Bracket	1	①-9
17	40XBB6410000	支架	Bracket	1	①-9

制动总泵

Master Cylinder

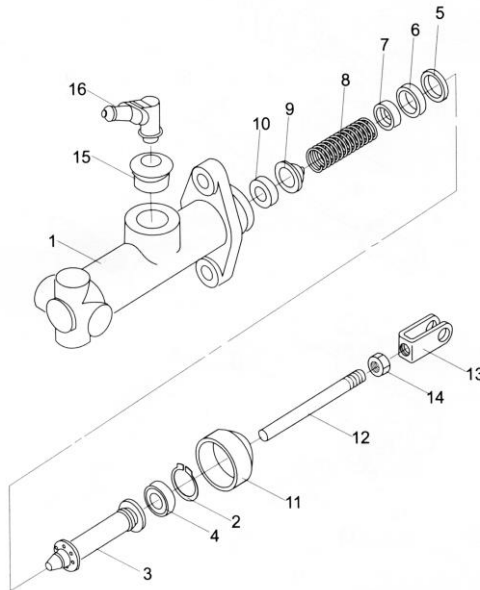

序号 Item No.	零件图号 Part No.	零部件名称 Part Description		数量 Q'ty	备注 Remark
		名称 Apellation	规格 Spec		
1	CKM3/4	缸体 Body, Cylinder		1	
2	Q43022	孔用弹性挡圈 Ring, Stopper		1	
3	CKM3/4-3505030	活塞弹簧总成 Piston		1	
4		前皮碗 Cup, Secondary		1	
5		衬套皮碗 Cup, Rubber		1	
6		主皮碗 Cup, Primary		1	
7		弹簧座 Seat, Spring		1	
8		弹簧 Spring		1	
9	CKM3/4-3505040	输液阀总成 Valve, Check		1	
10	CKM3/4-3505012	输液阀垫 Seat, Valve		1	

FORKLIFT PARTS CATALOGUE

11	CKM3/4-3505015	保护罩 Boots		1	
12	CKM3/4-3505020	推杆总成 Rod, Push		1	
13		支耳 Clevis		1	
14	GB6170	螺母 Nut	M8	1	
15		胶皮衬套 Bushing, Rubber		1	
16	厂标-59	进液连通螺栓 Bolt		1	



分配器操纵

Valve Control System

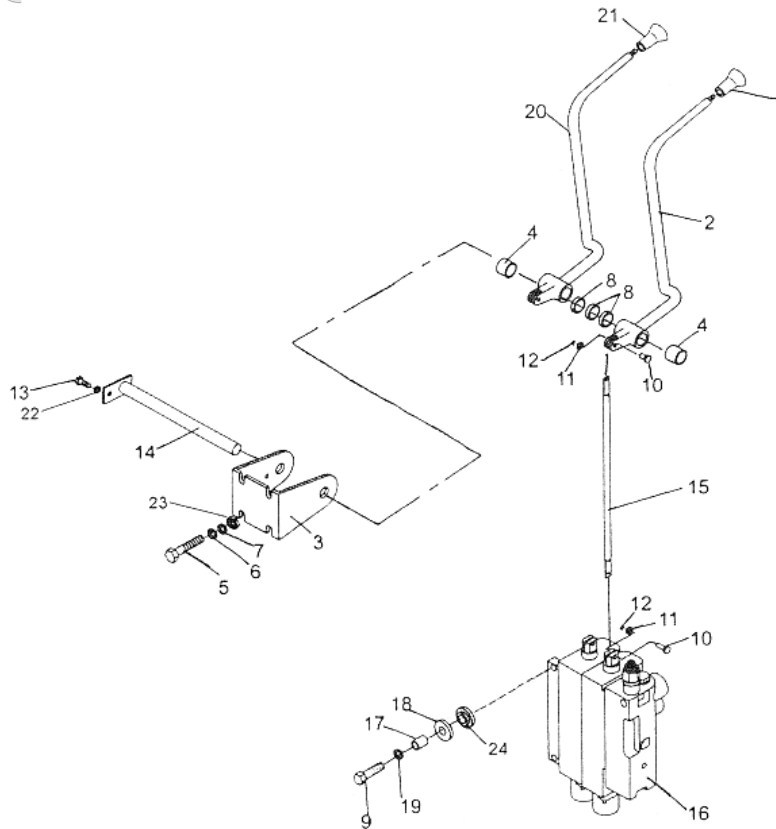

序号 Item No.	零件图号 Part No.	零部件名称 Part Description		数量 Q`ty	备注 Remark
		名称 Apellation	规格 Spec		
1	L91273-21200D	手柄球 Knob		1	
2	30XDB6820000	操纵杆组件 (B) Lever, Tilt(B)		1	
3	30XDB6800006	操纵杆托架		1	

DALIAN FORKLIFT CO.,LTD.

		Bracket Lever			
4	FZ-1.16.37	衬套 Bushing		2	
5	GB5781	螺栓 Bolt	M8×25	4	
6	GB97.1	垫圈 Washer	8	8	
7	GB859	垫圈 Washer	8	4	

序号 Item No.	零件图号 Part No.	零部件名称 Part Description		数量 Q'ty	备注 Remark
		名称 Appellation	规格 Spec		
8	30X6800005	薄垫片 Shim		3	
9	GB5786	螺栓 Bolt	M10×1.25×35	3	
10	30X6800001	销轴 Pin		4	
11	GB97.1	垫圈 Washer	5	4	
12	GB91	销 Pin	1.6×10	4	
13	GB5781	螺栓 Bolt	M6×12V	1	
14	30X6830000	销轴总成 Pin, Lever		1	
15	30V6800002	杆 Rob		2	
16	CDB2-F15	多路换向阀 Control valve		1	
17	30XDB6800001	限位钢管 Collar		3	
18	GB96	垫圈 Washer	10	3	
19	GB93	垫圈 Washer	10	3	
20	30XDB6810000	操纵杆组件 (A) Lever, tilt (A)		1	
21	L91273-21300D	手柄球 Knob, tilt		1	
22	GB93	垫圈 Washer	6	1	
23	GB6170	螺母 Nut	M8	4	

FORKLIFT PARTS CATALOGUE

24	30XDB6800002	减震垫 Rubber		3	
----	--------------	------------	--	---	--



变速箱操纵

Transmission System

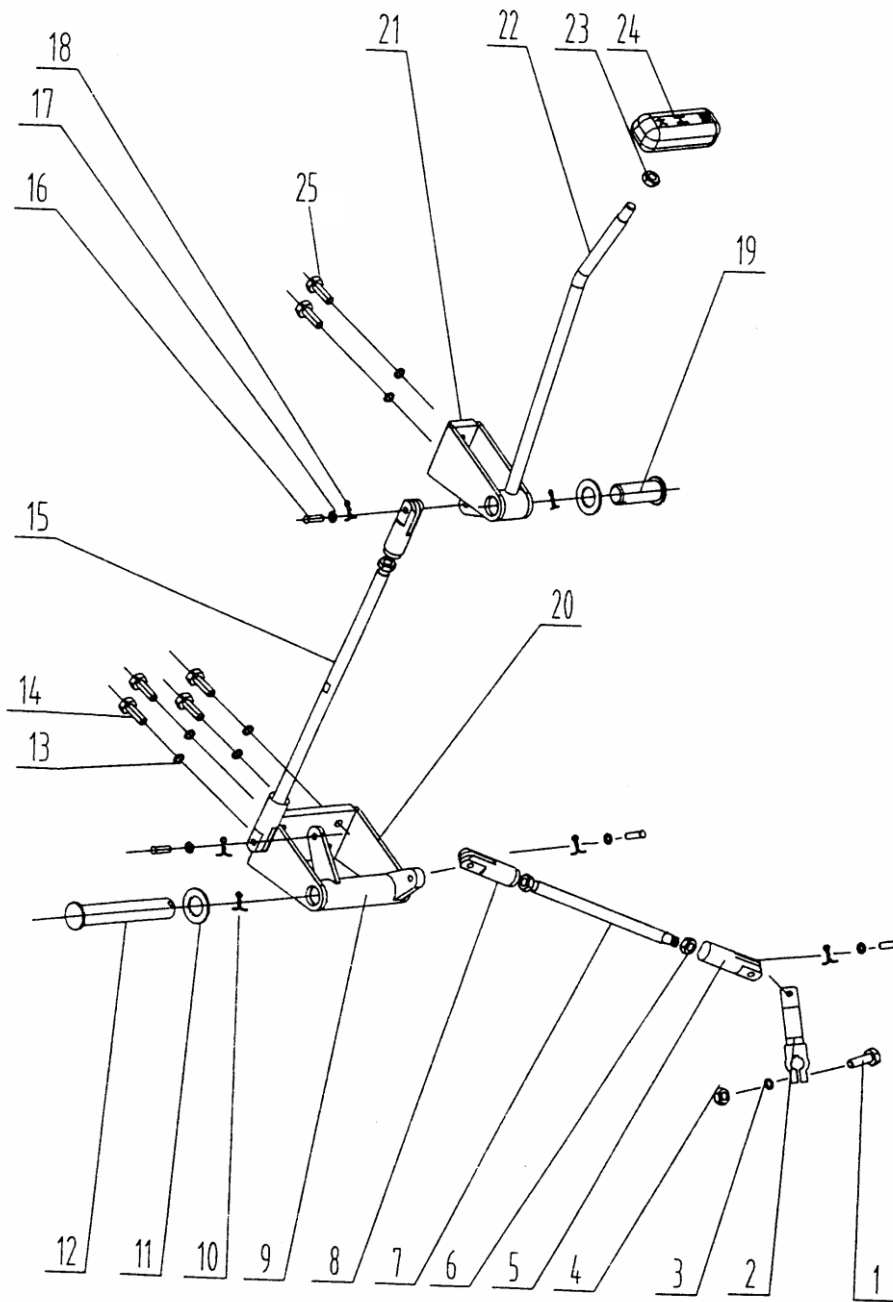

序号 Item No.	零件图号 Part No.	零部件名称 Part Description		数量 Q'ty	备注 Remark
		名称 Apellation	规格 Spec		
1	GB5783	螺栓 Bolt	M8×35	1	①-1~3 ②-1、③-2

FORKLIFT PARTS CATALOGUE

2	30XDB6510000	连杆 Linkage		1	①-1~3 ②-1、③-2
3	GB93	垫圈 Washer	8	7	①-1~3 ②-1、③-2
4	GB6170	螺母 Nut	M8	1	①-1~3 ②-1、③-2
5	30XDB6500001	接头I CapI		2	①-1~3 ②-1、③-2
6	A847.23.1.2-6	光小六角螺母 Nut		2	①-1~3 ②-1、③-2
7	30XDB6500002	调整杆 Adjust rod		1	①-1~3 ②-1、③-2
8	30XDB6500003	接头II Cap		2	①-1~3 ②-1、③-2
9	30XDB6520000	组合摇臂 Connect rocker		1	①-1~3 ②-1、③-2
10	GB91	销 Pin	5×30	2	①-1~3 ②-1、③-2
11	GB97.1	垫圈 Washer	20	2	①-1~3 ②-1、③-2
12	30XDB6500004	销轴 Pin		1	①-1~3 ②-1、③-2
13	GB97.1	垫圈 Washer	8	6	①-1~3 ②-1、③-2
14	GB5783	螺栓 Bolt	M8×25	4	①-1~3 ②-1、③-2
15	30XDB6500005	调整杆II Adjust rodII		1	①-1~3 ②-1、③-2
16	GB882	销轴 Pin	B6×20	4	①-1~3 ②-1、③-2
17	GB97.1	垫圈 Washer	6	4	①-1~3 ②-1、③-2
18	GB91	销 Pin	2×14	4	①-1~3 ②-1、③-2
19	GB882	销轴 Pin	B20×50	1	①-1~3 ②-1、③-2
20	30XDB6500006	支架I Support,shaftI		1	①-1~3 ②-1、③-2
21	30XDB6530000	支架II Support,shaftII		1	①-1~3 ②-1、③-2
22	30XDB6540000	操纵杆总成 Control,lever		1	①-1~3 ②-1、③-2
23	GB6172.1	螺母 Nut	M10	3	①-1~3 ②-1、③-2
24	30XDB6550000	手柄总成 Hand,lever		1	①-1~3 ②-1、③-2
25	GB5783	螺栓 Bolt	M8×20	2	①-1~3 ②-1、③-2



熄火操纵
Choke System

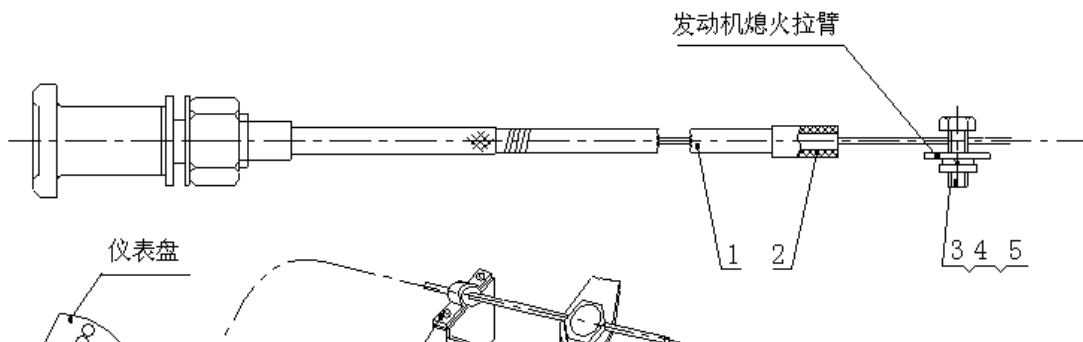



液压系统
Hydraulic System

序号 Item No.	零件图号 Part No.	零部件名称 Part Description		数量 Q'ty	备注 Remark
		名称 Apellation	规格 Spec		
1		风门拉线(L=1800) Line		1	①-1-3、7、8 ③-1、2
2	30X6610001	套 Cannula		1	①-1-3、7、8 ③-1、2
3	20W3100003	熄火线螺栓 Bolt		1	①-1-3、7、8 ③-1、2
4	GB93	垫圈 Washer	6	3	①-1-3、7、8 ③-1、2
5	GB6170	螺母 Nut	M6	1	①-1-3、7、8 ③-1、2
6	GB67	螺钉 Bolt	M5×10	2	①-1-3、7、8 ③-1、2
7	30W6600001	夹子 Clip		1	①-1-3、7、8 ③-1、2
8	GB93	垫圈 Washer	5	2	①-1-3、7、8 ③-1、2
9	30XDA6600001	支板 Under prop		1	①-1-3、7、8 ③-1、2
10	GB5781	螺栓 Bolt	M6×20	2	①-1-3、7、8 ③-1、2

FORKLIFT PARTS CATALOGUE

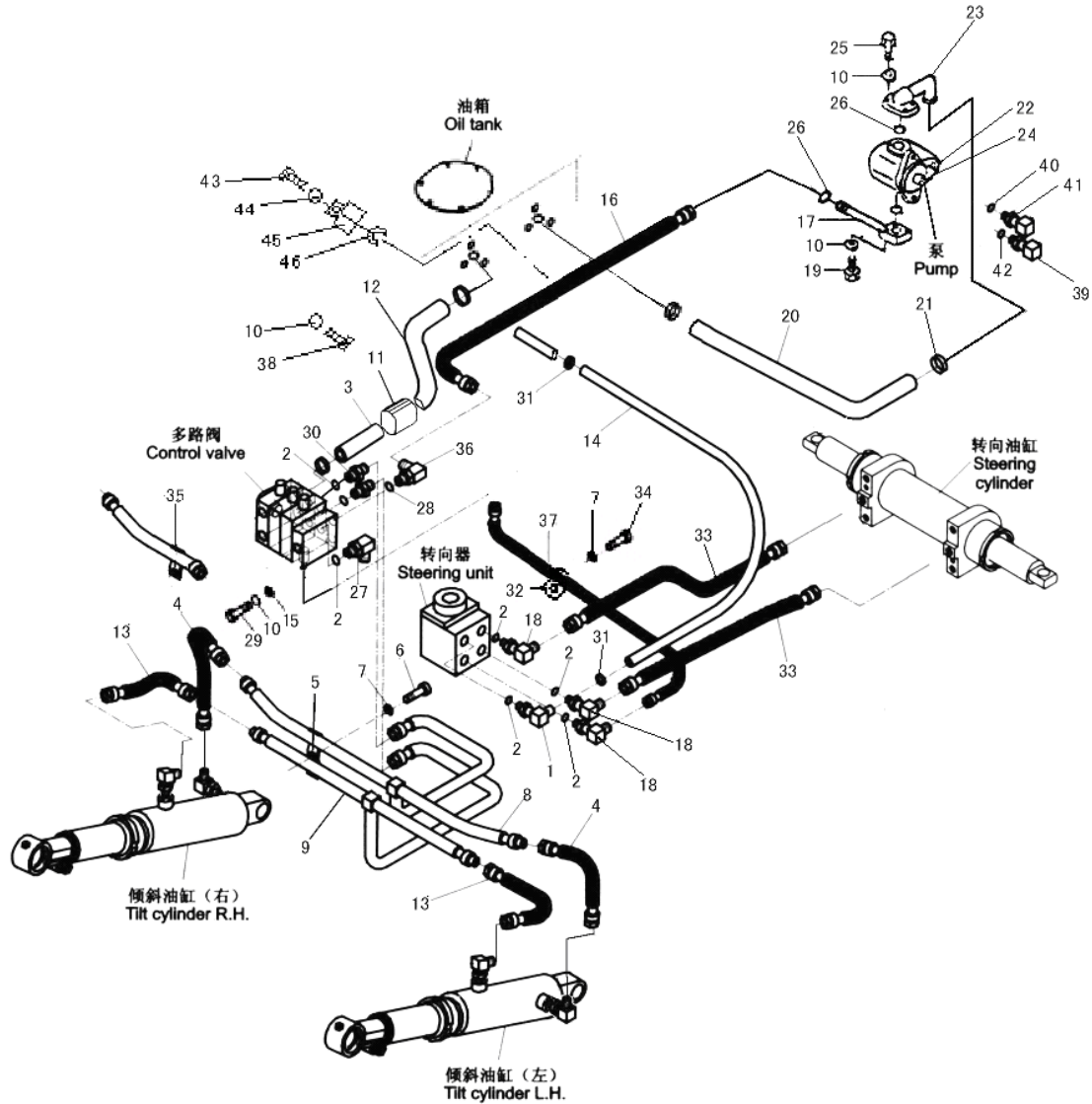

序号 Item No.	零件图号 Part No.	零部件名称 Part Description		数量 Q'ty	备注 Remark
		名称 Apellation	规格 Spec		
1	30V7000011	接头体 Nipple		1	
2	GB3452.1	O形密封圈 O-Ring	17×2.65	7	
3	20XDB7100005	回油管 1 Hose1		1	
4	30XDB71D60000	倾斜胶管(前) Hose H.P		2	
5	30X7000014	管夹 Clip		4	

序号 Item No.	零件图号 Part No.	零部件名称 Part Description		数量 Q'ty	备注 Remark
		名称 Apellation	规格 Spec		

DALIAN FORKLIFT CO.,LTD.

6	GB5781	螺栓 Bolt	M8×25	2	
7	GB93	垫圈 Washer	8	8	
8	20XDB7102000	倾斜油管 Hose H.P		1	
9	20XDB7101000	倾斜油管 Hose H.P		1	
10	GB97.1	垫圈 Washer	10	4	① ②-2、4 ③
	GB97.1	垫圈 Washer	10	13	②-1、3
11	20XDB7103000	四通 Valve		1	
12	20XDB7100006	回油管 2 Hose2		1	
13	30XDB71D50000	倾斜胶管(后) Hose F.P		2	
14	HG/T3041	输油胶管 Hose	13×21×1400	1	
15	GB6170	螺母 Nut	M10	1	
16	20XDB7100002	油泵出油管 Hose		1	① ②-2、4 ③
16	30VBB7130000	油泵吸油管 I Hose		1	②-1、3
17	30VBB7110000	出油口法兰 Flanger		1	②-1、3
18	J20.3-FB1-8c	管接头体 8c Nipple		3	
19	GB5786	螺栓 Bolt	M10×1.25×45	4	②-1、3
20	40XBB7100001	吸油管 Hose		1	①-1、③-1
20	30XDB71D00001	吸油管 Hose		1	①-2~4、7、8 ③-2、3
20	30VFB71D00001	吸油管 Hose		1	①-5、9②-2、4
20	30XRB71D00001	吸油管 Hose		1	①-6、③-4
20	30VBB7100001	油泵吸油管 I Hose		1	②-1、3
	30VBB7100002	油泵吸油管 III Hose			
	30VBB7120000	油泵吸油管 II Hose			
21	JB/ZQ3777	喉箍 Clip	35-50	6	
22	CBHZG-F32-ALHL	齿轮泵 Pump		1	①-2~4、7、8 ③-2、3
22	CBHZG-F32-ALφL	齿轮泵 Pump		1	①-5、9
22	CBHZG-F32-ALφ	齿轮泵 Pump		1	①-1、6、②-2、4 ③-1、4
22	CBT-F432-AFH	齿轮泵 Pump		1	②-1、3
23	15W7020000	进油口法兰 Flanger		1	②-1、3

序号 Item	零件图号 Part No.	零部件名称 Part Description	数量 Q'ty	备注 Remark
------------	------------------	---------------------------	------------	--------------

FORKLIFT PARTS CATALOGUE

No.		名称 Apellation	规格 Spec		
24	30X7000011	垫 Shim		1	
25	GB5786	螺栓 Bolt	M10×1.25×25	4	②-1、3
26	GB3452.1	O形密封圈 O-Ring	31.5×3.55	2	②-1、3
27	J20.3-FB4-14b	管接头 Joint	14b	1	
28	GB3452.1	O形密封圈 O-Ring	18×2.65	1	
29	GB5781	螺栓 Bolt	M10×30	1	
30	J20.3-FB1-6b	管接头体 Joint	6b	2	
31	JB/ZQ3777	喉箍 Clip	22~30	2	
32	30XDB7000004	管夹 Clip		2	
33	JB1887	胶管接头 Hose Joint	8I-1600	2	
34	GB5781	螺栓 Bolt	M8×16	4	
35	20XDB7104000	接管总成 Hose		1	
36	J20.3-FB4-18	管接头 Joint	18	1	
37	20XDB7100001	胶管接头 Hose Joint	8I-400	1	
38	GB5786	螺栓 Bolt	M10×1.25×16	1	
39	J20.3-FB1-16	管接头体 Joint	16	1	① ②-2、4 ③
40	JB982	垫圈 Washer	33	1	① ②-2、4 ③
41	J20.3-FB6-32	P型接头 P-Joint	32	1	① ②-2、4 ③
42	GB3452.1	O形密封圈 O-Ring	20×2.65	1	① ②-2、4 ③
43	GB5786	螺栓 Bolt	M10×1.25×20	1	①-1 ②-1、3、 ③-1
44	GB93	垫圈 Washer	10	1	①-1 ②-1、3、 ③-1
45	L91876-00500	管夹 Clip		1	①-1 ②-1、3、 ③-1
46	L91876-00600	衬套 Bushing		1	①-1 ②-1、3、 ③-1
47					
48					



护顶架

Overhead Guard

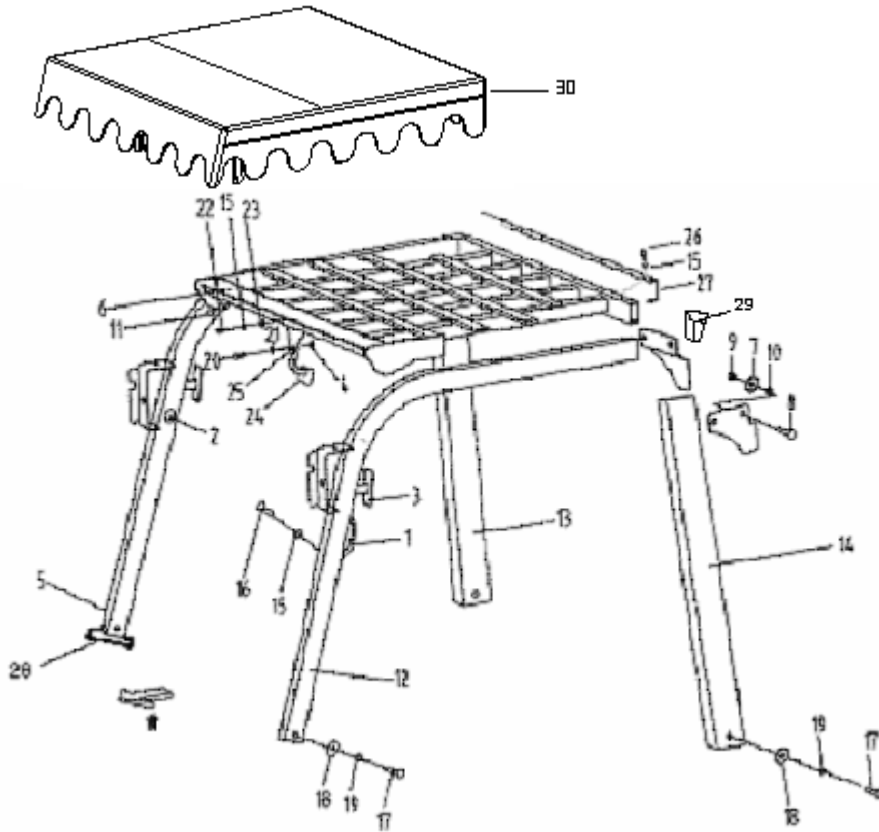

序号 Item No.	零件图号 Part No.	零部件名称 Part Description		数量 Q`ty	备注 Remark
		名称 Apellation	规格 Spec		
1	A22A5-10412G	把手 Handle		1	
2	30X0200003	出线胶圈 Ring, Rubber		2	
3	CA-1046	倒车镜 Viewfinder		2	
4	GB6170	螺母 Nut		3	
5	30XDB02D13000	前右腿总成 Leg,R.H.front		1	
6	30XDB02D12000	顶架 Overhead Guard		1	
7	GB97.1	垫圈 Washer	12	4	

序号 Item No.	零件图号 Part No.	零部件名称 Part Description		数量 Q`ty	备注 Remark
		名称 Apellation	规格 Spec		

FORKLIFT PARTS CATALOGUE

8	30V0200001	螺栓 Bolt		4	
9	GB6170	螺母 Nut	M12	4	
10	GB93	垫圈 Washer	12	4	
11	30XDB0200002	胶管 Hose		1	
12	30XDB02D11000	前左腿总成 Leg,L.H.front		1	
13	30XDB02D30000	后右腿总成 Leg,R.H.rear		1	
14	30XDB02D20000	后左腿总成 Leg,L.H.rear		1	
15	GB93	垫圈 Washer	6	7	
16	GB67	螺钉 M6×25 Bolt		2	
17	L91215-04700	螺栓 Bolt		4	
18	GB96.1	垫圈 Washer	16	4	
19	GB93	垫圈 Washer	16	4	
20	GB5781	螺栓 Bolt	M8×35	1	
21	GB93	垫圈 Washer	8	1	
22	GB5781	螺栓 Bolt	M6×20	2	
23	GB6170	螺母 Nut	6	2	
24	CA6440	后视镜 Viewfinder		1	
25	30XDB0200003A	联板 Board		1	
26	GB67	螺钉 Bolt	M6×10	3	
27	30XDB02D40000	护盖 Cover		1	
28	20XDB0200001	密封圈 Ring		2	
29	30XDB0211002	堵盖 Cover		2	
30	30XDB02D50000	防雨篷 Waterproof Cloth		1	



消音器

Muffler System

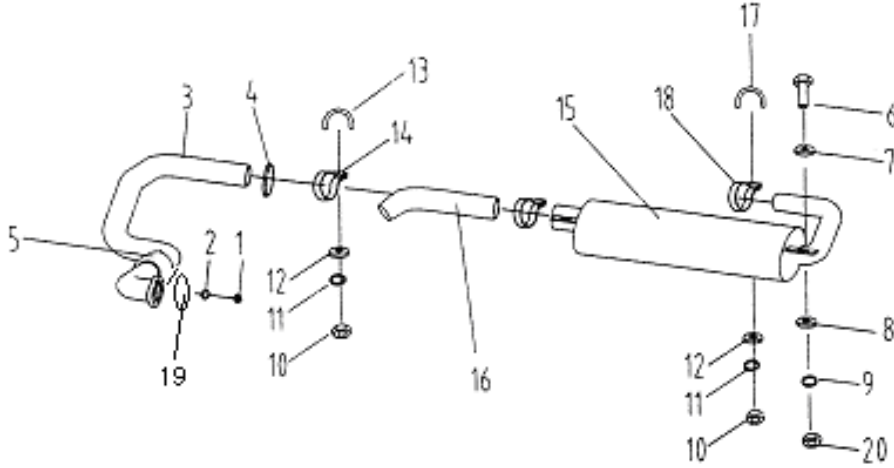

序号 Item No.	零件图号 Part No.	零部件名称 Part Description		数量 Q'ty	备注 Remark
		名称 Apellation	规格 Spec		
1	GB6170	螺母 Nut	M10	2	①-2~4、6~8 ③-2~4
1	GB6171	螺母 Nut	M10×1.25	4	①-5
1	GB6170	螺母 Nut	M8	2	②-2、4
1	GB6171	螺母 Nut	M10×1.25	3	②-1、3
1	GB6170	螺母 Nut	M8	4	①-9
2	GB93	垫圈 Washer	10	2	①-2~4、6~8 ③-2~4
2	GB93	垫圈 Washer	10	4	①-5
2	GB93	垫圈 Washer	8	2	②-2、4
2	GB93	垫圈 Washer	10	3	②-1、3
2	GB93	垫圈 Washer	8	4	①-9
3	30XDB32D10000	排气管 Pipe,exhaust		1	①-2~4、7~8 ③-2、3
3	30XF1B3210000	排气管 Pipe,exhaust		1	①-5
3	30XFB3210000	排气管 Pipe,exhaust		1	①-6、③-4
3	30VFB3210000	排气管 Pipe,exhaust		1	②-2、4
3	30VBB3210000	排气管 Pipe,exhaust		1	②-1、3
3	30XSB3210000	排气管 Pipe,exhaust		1	①-9

FORKLIFT PARTS CATALOGUE

序号 Item No.	零件图号 Part No.	零部件名称 Part Description		数量 Q'ty	备注 Remark
		名称 Apellation	规格 Spec		
4	JB/ZQ3777-1986	喉箍 Nipple	35-50	6	①-2~4、6~8 ②、③-2~4
4	JB/ZQ3777-1986	喉箍 Nipple	35-50	4	①-5
5	30XDB3200001	编织罩 Basketwork	50×1×2000	1	①-2~4、6~8 ③-2~4
5	30XF1B3200001	编织罩 Basketwork	450×400×1	1	①-5
5	30VFB3200001	编织罩 Basketwork	50×1×1800	1	②-2、4
5	30VBB3200001	编织罩 Basketwork	50×1×2000	1	②-1、3
6	GB5782	螺栓 Bolt	M10×55	3	①-2~4、6~9 ②、③-2~4
6	GB5782	螺栓 Bolt	M10×60	2	①-5
7	30X3200002	垫 Shim		3	①-2~4、6~9 ②、③-2~4
7	30X3200002	垫 Shim		2	①-5
8	30X3200003	垫 Shim		6	①-2~4、6~9 ②、③-2~4
8	30X3200003	垫 Shim		4	①-5
9	GB97.1	垫圈 Washer	10	3	①-2~4、6~9 ②、③-2~4
9	GB96.1	垫圈 Washer	10	2	①-5
10	GB6170	螺母 Nut	M8	6	
11	GB93	垫圈 Washer	8	6	
12	GB97.1	垫圈 Washer	8	6	
13	KD2.8LMT-KL-09A	U型螺栓 U-Bolt		2	
14	KD2.8LMT-KL-10A	固定夹 Clip		2	
15	30XDB3230000	消音器总成 Muffler		1	①-2~4、6~8 ③-2~4
15	30XF1B3230000	消音器总成 Muffler		1	①-5、9 ②-2、4
15	30VBB3230000	消音器总成 Muffler		1	②-1、3
16	30XDB3200002	连接管 Pipe		1	①、③-2~4
16	30VFB3200002	连接管 Pipe		1	②-2、4
16	30VBB3200002	连接管 Pipe		1	②-1、3
17	KD2.8LMT-KL-09	U型螺栓 U-Bolt		1	
18	KD2.8LMT-KL-10	固定夹 Clip		1	
19	30X3200001	垫 Shim		1	①-5
20	GB6170	螺母 Nut	M10	3	

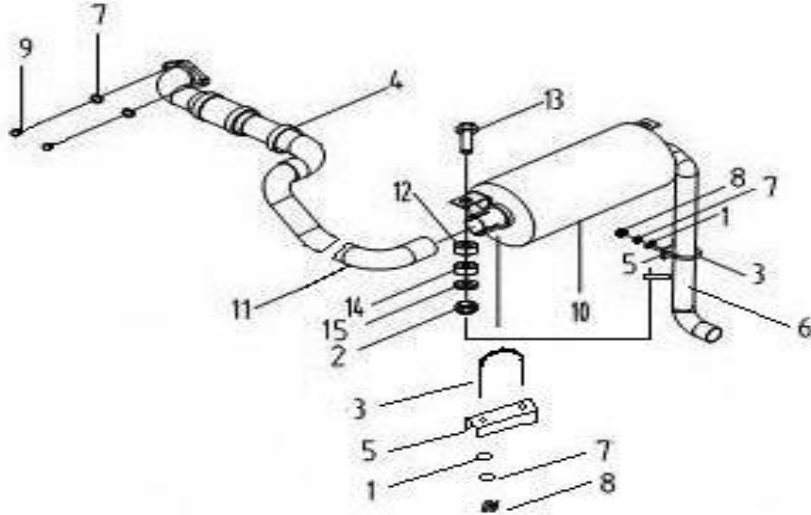

序号 Item No.	零件图号 Part No.	零部件名称 Part Description		数量 Q'ty	备注 Remark
		名称 Apellation	规格 Spec		
01	GB97.1	垫圈 Washer	8	3	①-1 ③-1
02	GB6170	螺母 Bolt	M10	3	①-1 ③-1
03	40XBB3200004	U型螺栓 U-Bolt		3	①-1 ③-1
04	30XBB3210000	排气管 Nipple		1	①-1 ③-1
05	40XBB3200003	管夹 Clip		3	①-1 ③-1
06	30XBB3220000	尾管总成 Pipe		1	①-1 ③-1
07	GB93	垫圈 Washer	8	8	①-1 ③-1
08	GB6170	螺母 Nut	M8	6	①-1 ③-1
09	GB5783	螺栓 Bolt	M8×25	2	①-1 ③-1
10	40XBB3230000	消音器总成 Muffler		1	①-1 ③-1
11	40XBB3200002	连接管 Pipe		1	①-1 ③-1
12	30X3200002	垫 Shim		3	①-1 ③-1
13	GB5782	螺栓 Bolt	M10×55	3	①-1 ③-1
14	30X3200003	垫 Shim		6	①-1 ③-1
15	GB97.1	垫圈 Washer	10	3	①-1 ③-1
16	40XBB3200001	垫 Shim		1	①-1 ③-1

FORKLIFT PARTS CATALOGUE



标牌组件

Decal

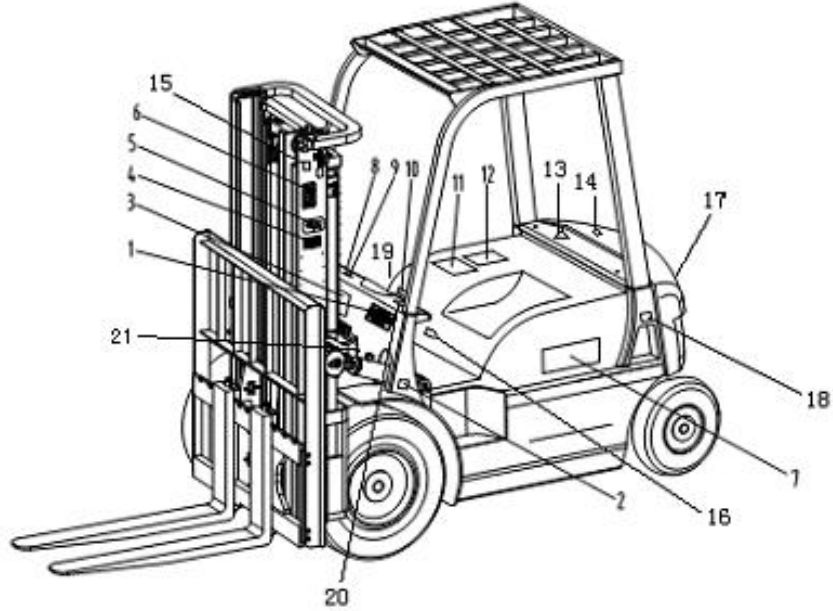

序号 Item No.	零件图号 Part No.	零部件名称 Part Description		数量 Q`ty	备注 Remark
		名称 Apellation	规格 Spec		
1	20X0200002	铭牌 Name plate		1	3t 国内 home
1	20X0200016	铭牌 Name plate		1	3t 国外 Overseas
1	35XCB0700003	铭牌 Name plate		1	3.5t 国内 home
1	35XCB0700004	铭牌 Name plate		1	3.5t 国外 Overseas
2	30X0700003	轮胎气压标牌 Decal, model		1	①②
2	L91183-02100	轮胎气压标牌 Decal, model		1	③
3	30X0700004	供油系统标牌 Decal, hydraulic		1	国内 home
3	30X0700017	供油系统标牌 Decal, hydraulic		1	国外 Overseas
4	30X0700005	载荷曲线牌 Decal, capacity chart		1	3t 国内 home
4	30X0700018	载荷曲线牌 Decal, capacity chart		1	3t 国外 Overseas

DALIAN FORKLIFT CO.,LTD.

序号 Item No.	零件图号 Part No.	零部件名称 Part Description		数量 Q`ty	备注 Remark
		名称 Apellation	规格 Spec		
4	35XCB0700001	载荷曲线牌 Decal,capacity chart		1	3.5t 国内 home
4	35XCB0700002	载荷曲线牌 Decal,capacity chart		1	3.5t 国外 Overseas
5	20X0700051	CE 标牌 Decal,CE		1	国外 Overseas
5	DCJ7.02	产品商标 Decal,CE		1	国内 home
6	30X0700032	标牌 Decal, safety		1	
7	30X0700036	车架侧面标牌 Decal, model		1	3t 国内 home
7	30X0700037	车架侧面标牌 Decal, model		1	3t 国外 Overseas
7	35XCB0700005	车架侧面标牌 Decal, model		1	3.5t 国内 home
7	35XCB0700006	车架侧面标牌 Decal, model		1	3.5t 国外 Overseas
8	30X0700006	倾斜指示标牌 Decal,tilt		1	
9	30X0700007	升降指示标牌 Decal,lift		1	
10	30X0700014	警告标牌 Decal, warning		1	
11	30X0700009	注意事项标牌 Decal, driver notice		1	国内 home
11	30X0700019	注意事项标牌 Decal, driver notice		1	国外 Overseas
12	30X0700011	使用须知标牌 Decal, guide		1	国内 home
12	30X0700020	使用须知标牌 Decal, guide		1	国外 Overseas
13	100X0700016	警告牌 Decal, warning		1	
14	91282-14100	警示标牌 Decal, warning		1	
15	15RA0700026	起吊标牌 Decal,rise		1	
16	30X0700013	油容量标牌 Decal,oil capability		1	
17	60XFA070013	标牌 Decal		1	
18	30X0700010	燃油标牌 Decal,fuel		1	
19	30X0700012	工作油标牌 Decal,hydraulic oil		1	
20	30X0700008	换向指示牌 Decal,direction		1	用于液力车 Con-type
21	30X0700041	标牌 Decal		2	

FORKLIFT PARTS CATALOGUE



液化汽车燃气系统
Gas Combustion System

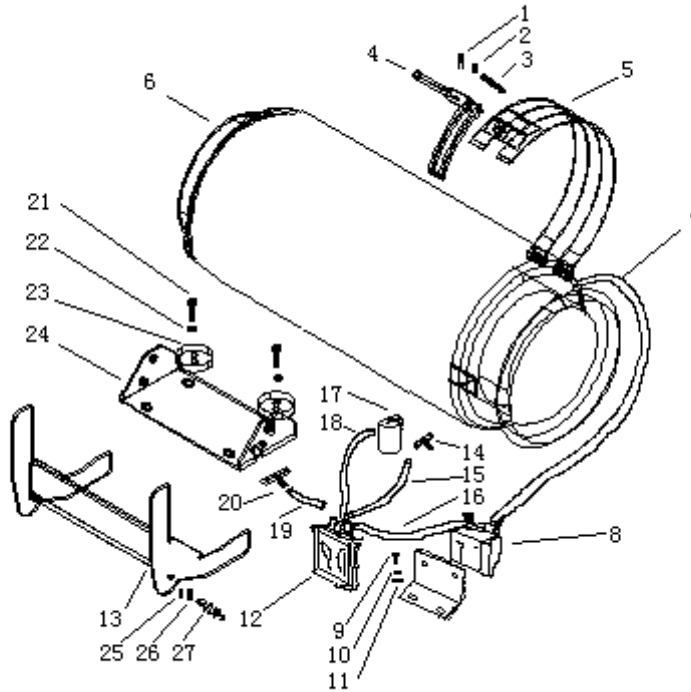

序号 Item No.	零件图号 Part No.	零部件名称 Part Description		数量 Q`ty	备注 Remark
		名称 Apellation	规格 Spec		
01	GB882	销轴 Pin	4×20	2	②-4
02	GB97.1	垫圈 Washer	5	2	②-4
03	GB91	销 Pin	1.6×10	2	②-4
04	30Z3612001	手柄 Handspike		1	②-4
05	30Z3612201	卡带 Belt		1	②-4
06	CYSW314-50-2.2VIII A	LPG 气瓶 Gas Bottle		1	②-4
07	17920 L1201	高压胶管 Hose		1	②-4
08	17904 50K01	液化气电磁阀 Elecromagnet		1	②-4
09	GB5781	螺栓 Bolt		2	②-4
10	GB93	垫圈 Washer	8	4	②-4
11	GB96	垫圈 Washer	8	2	②-4
12	16300 50K00	蒸发器 Evaporator		1	②-4

DALIAN FORKLIFT CO.,LTD.

序号 Item No.	零件图号 Part No.	零部件名称 Part Description		数量 Q`ty	备注 Remark
		名称 Apellation	规格 Spec		
13	30Z3611000	支架 Evaporator		1	②-4
14	14075 05H10	三通 Three Road		1	②-4
15	14055 50K10	蒸发器出水管 Hose		1	②-4
16	17504 50K10	输气铜管 Hose		1	②-4
17	16329 50K20	混合器 Composite		1	②-4
18	17527 50K10	输气胶管 Hose		1	②-4
19	02187 26601	输气胶管 Hose		1	②-4
20	14960 W1304	三通 Three Road		1	②-4
21	GB5781	螺栓 Bolt		4	②-4
22	GB93	垫圈 Washer		4	②-4
23	30Z3600001	减震垫 Absorber		4	②-4
24	30Z3610001	底座 Base		1	②-4
25	GB96.1	垫圈 Washer	12	4	②-4
26	GB894.1	挡圈 Washer	12	4	②-4
27	30Z3610004	拉簧 Spring		1	②-4



电气原理图

Electric Principle

CPCD30CB、CPCD30DB、CPC30BB、CPC30CB、CPCD35CB 电气原理图

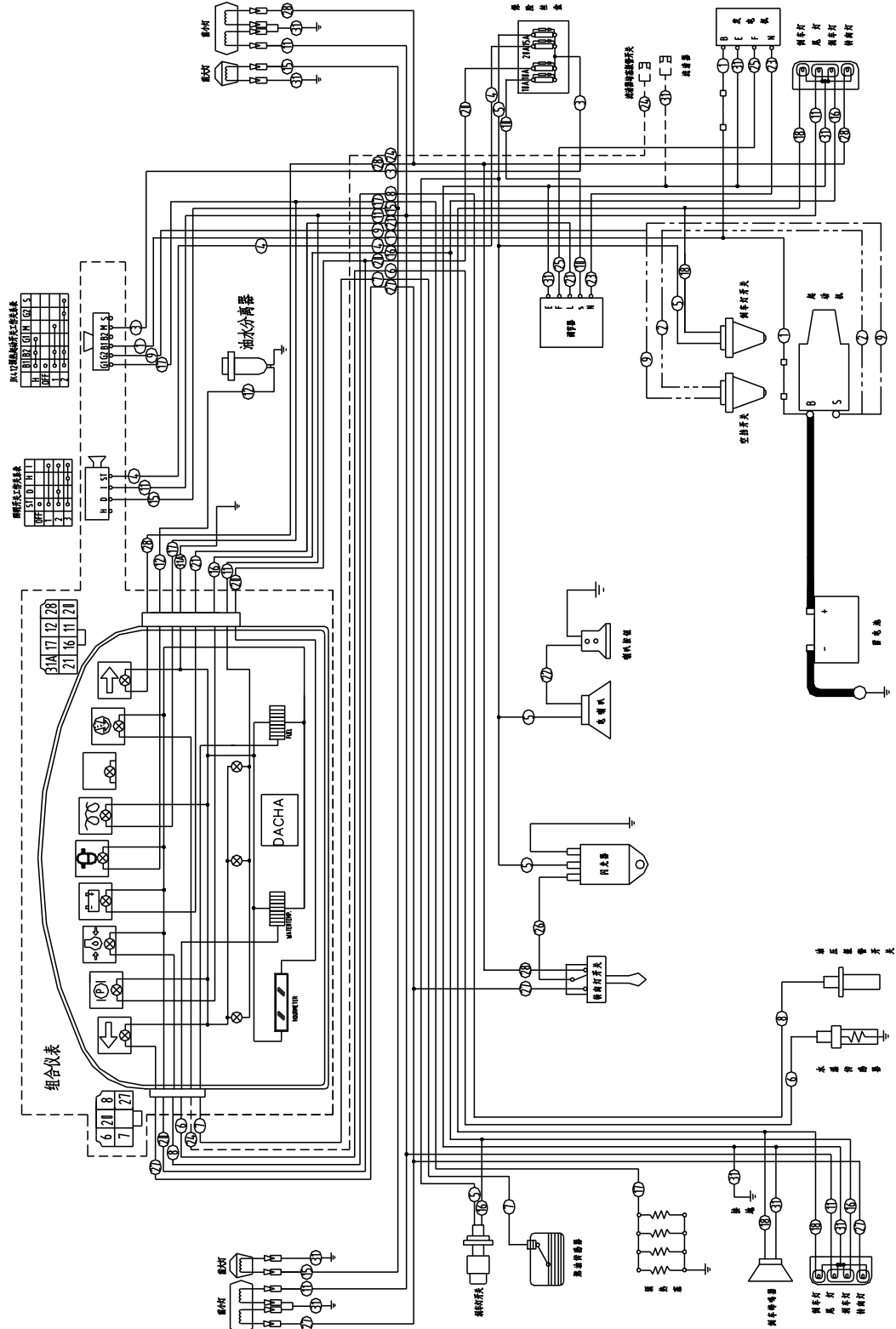

注：图中点划线为9号机械传动叉车用，双点划线为液力传动叉车用。

FORKLIFT PARTS CATALOGUE



电气原理图

Electric Principle

CPCD30EB、CPCD35EB 电气原理图



电气原理图
Electric Principle

CPQD30BB、CPQ30BB 电气原理图

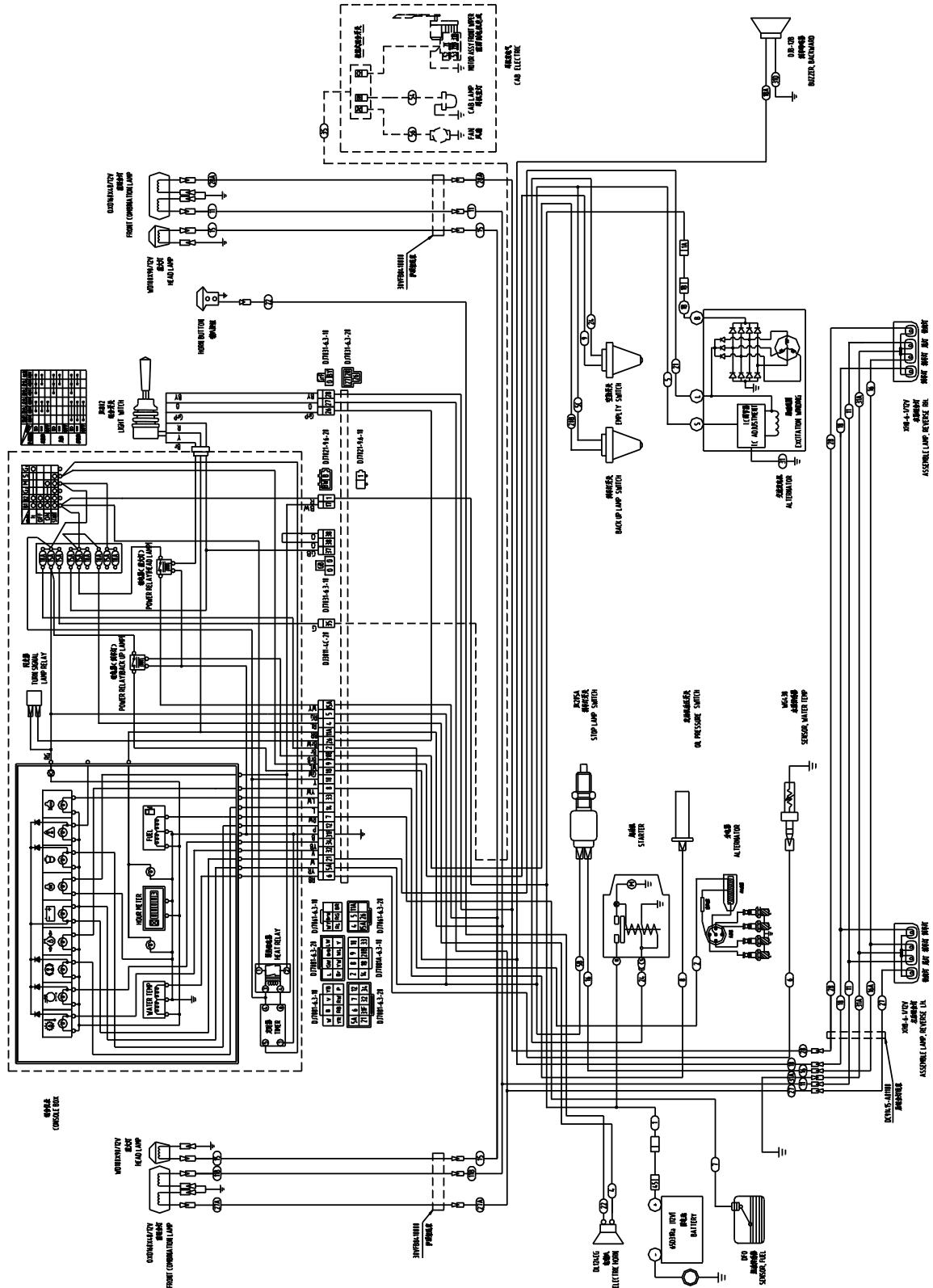

序号 Item No.	零件图号 Part No.	零部件名称 Part Description		数量 Q`ty	备注 Remark
		名称 Apellation	规格 Spec		
1	H2002/12V	组合仪表 Meter ass'y		1	①-1~8 ③-1~4 ②-2、4
2	HZB137-DC	组合仪表 Meter ass'y		1	②-1、3
3	DFO	燃油传感器 Fuel sensor		1	
4	DSW-M16×1.5	水温传感器 Water temp sensor		1	①-5
5	DSO-R3/8	水温传感器 Water temp sensor		1	①-1~4、6~8 ②-2、4 ③-1~4
6	WG438	水温传感器 Water temp sensor		1	②-1、3
7	WD100×90/12V	前大灯 Head lamp		2	
8	QXD160×48/12V	前组合灯 Front combination lamp		2	
9	JK205A	刹车灯开关 Switch/stop lamp		1	
10	DJB-12B	倒车蜂鸣器 Back buzzer		1	
11	XH8-6-1/12V	后组合灯 Rear combination lamp		2	
12	DL124G	电喇叭 Electric horn		1	
13	65D31Ra	蓄电池 Battery		1	②-1~4
14	95D31Ra	蓄电池 Battery		1	①-1~8 ③-1~4
15	HG4190/012(2)-1Z9	继电器 Relay		1	①-5、6 ③-4
16	HG4190/012(2)-1Z9	继电器 Relay		2	①-4 ②-2、4 ③-3
17	BX2081X	保险丝盒 Fuse box		1	

FORKLIFT PARTS CATALOGUE

序号 Item No.	零件图号 Part No.	零部件名称 Part Description		数量 Q`ty	备注 Remark
		名称 Apellation	规格 Spec		
18	JFT147-14B	调节器 Adjuster		1	①-2~4 ①-7、8 ③-2、3
19	JQ1030/04	预热继电器 Warm-up relay		1	①-1 ③-1
20	JC-3	方向开关 Switch/direction		1	①-4~6 ②-2、4 ③-3、4
21	SG152	闪光器 Flasher		1	
22	JK802	照明开关 Switch/turning and lighting		1	②-1、3