

第五部分 操纵系统目录

Part V Control system contents

CPCD20/25-XRG71	CPCD20/25-XRG72	CPCD20/25-XRG72F	CPC20/25-XRG72	CPCD20/25-XRG72J
CPC20/25-XRG72J	CPCD20/25-XRW10	CPCD20/25-XRW10B	CPC20/25-XRW10	CPCD20/25-XRW10F
CPCD20/25-XRW33B	CPCD20/25-XRW33F	CPCD20/25-XRW43	CPCD20/25-XRW43B	CPCD20/25-XRW43F
CPCD20/25-XRW73	CPCD20/25-XRW55B	CPCD20/25-XRW55F	CPC20/25-XRW55	CPCD20/25-XRW56
CPCD20/25-XRW56B	CPCD20/25-XRW56F	CPQD20/25-XRW22	CPQD20/25-XRW22B	CPQYD20/25-XRW22
CPCD20/25-XRG2	CPCD20/25-XRW92F	CPQD20/25-XRW22F	CPQYD20/25-XRW22F	CPYD20/25-XRW52F
CPCD20/25-XRG72JF	CPQYD20/25-XRW22B			

序号 Item	名称 Description	适用车型 Serial No.	页码 Page
图 1 Fig. 1	制动微动踏板总成 Brake and inching pedal assy		5-1
图 2 Fig. 2	制动微动踏板总成 Brake and inching pedal assy		5-5
图 3 Fig. 3	制动离合踏板总成 Brake clutch pedal assy		5-9
图 4 Fig. 4	制动总泵总成 Brake pump assy	除外/Except 全部车型All models of truck	5-13

图 5 Fig. 5	油门操纵总成(电子) Throttle control assy (Electron)		5-14
图 6 Fig. 6	油门操纵总成 Throttle control assy		5-15
图 7 Fig. 7	油门操纵总成 Throttle control assy		5-18
序号 Item	名称 Description	适用车型 Serial No.	页码 Page
图 8 Fig. 8	换档操纵总成 Change over control assy		5-20
图 9 Fig. 9	手制动操纵 Hand brake control	全部车型 All models of truck	5-21
图 10 Fig. 10	制动微动踏板总成 Brake and inching pedal assy		5-23
图 11 Fig. 11	制动总泵总成 Brake and inching pedal assy		5-25
图 12 Fig. 12	微动推杆支架 Inching Budge push-rod stents		5-26

<p>图 1 制动微动踏板总成 Fig. 1 Brake and inching pedal assy</p>	<p>CPCD20/25-XRG71 CPCD20/25-XRW43 CPQYD20/25-XRW22</p>	<p>CPCD20/25-XRG72 CPCD20/25-XRW73 CPCD20/25-XRG2</p>	<p>CPCD20/25-XRG72J CPCD20/25-XRW56</p>	<p>CPCD20/25-XRW10 CPQD20/25-XRW22</p>
---	---	---	---	--



图 1 制动微动踏板总成
Fig. 1 Brake and inching pedal assy

CPCD20/25-XRG71 CPCD20/25-XRG72 CPCD20/25-XRG72J CPCD20/25-XRW10
 CPCD20/25-XRW43 CPCD20/25-XRW73 CPCD20/25-XRW56 CPQD20/25-XRW22
 CPQYD20/25-XRW22 CPCD20/25-XRG2

序号 Item	物料码 Part No	名称 Description	数量 Qty	备注或适用车型 Remarks or Serial No	原物料码 Original Part No
A	20510000082	制动微动踏板总成	1	包含/INC: 1-42	N160-510000-001
1	205100180001	踏板垫	2		N163-512001-000
2	205100170043	制动踏板	1		N160-514100-001
3	300170040003	油杯M6	1		G001152-006000-00
4	310010010032	螺栓	1		N163-510002-000
5	300020010006	螺母M10	3		G006170-000010-00
6	300060030013	挡圈28	1		G0894P1-000028-00
7	205100090013	垫片	1		N163-510004-000
8	205100320007	套	2		N163-514001-000
9	205100270001	止推圈	2		N163-512002-000
10	205100050013	弹簧	2		N163-510003-000
11	205100170033	微动踏板	1		N160-511100-000
12	205100320009	套	2		N163-512003-000
13	300020300006	螺母M8	3		G006172-000008-00
14	300030010015	垫圈8	2		G000093-000008-00

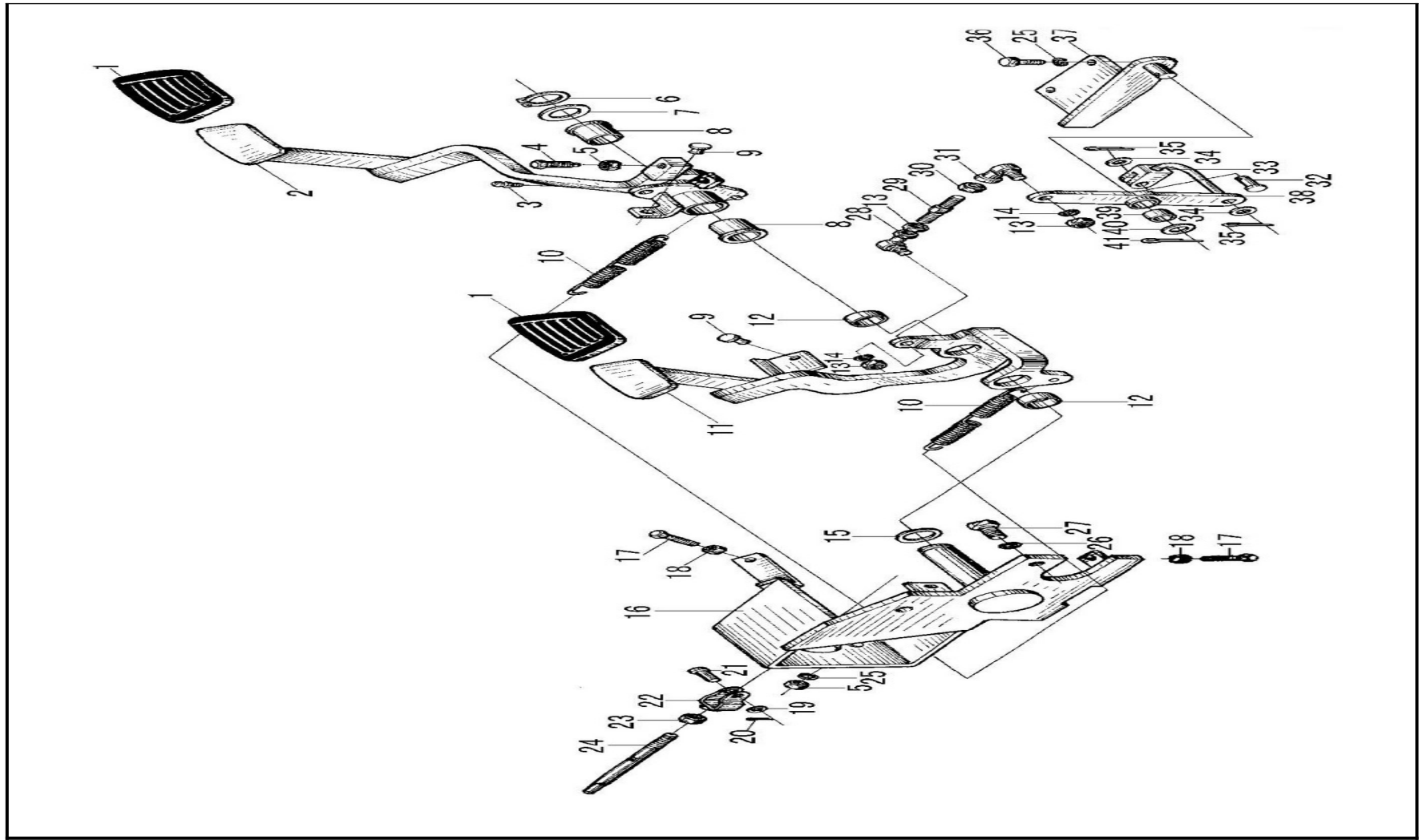

图 1 制动微动踏板总成 Fig. 1 Brake and inching pedal assy	CPCD20/25-XRG71	CPCD20/25-XRG72	CPCD20/25-XRG72J	CPCD20/25-XRW10		
	CPCD20/25-XRW43	CPCD20/25-XRW73	CPCD20/25-XRW56	CPQD20/25-XRW22		
	CPQYD20/25-XRW22	CPCD20/25-XRG2				
	序号 Item	物料码 Part No	名称 Description	数量 Qty	备注或适用车型 Remarks or Serial No	原物料码 Original Part No
	15	205100090013	垫片	1		N163-510004-000
	16	205100080004	底座	1		N163-511000-001
	17	300010040178	螺栓M8×30	2		G005783-008030-00
	18	300020010016	螺母M8	2		G006170-000008-00
	A2	205100230006	推杆总成	1	包含INC:19-24	N163-513000-000
	19	300030100010	垫圈8	1		G000848-000008-00
	20	205100160010	锁销1.6B	1		N163-513002-000
	21	300050040038	销轴B8×24	1		G000882-008024-01
	22	205100210011	推耳	1		N163-513100-000
	23	300020010006	螺母M10			G006170-000010-00
	24	205100220012	推杆	1		N163-513001-000
	25	300030010001	垫圈10	4		G000093-000010-00
	26	300030010002	垫圈12	2		G000093-000012-00
	27	300010060024	螺栓M12×1.25×25	2		G005786-012025-00

	42	205100310015	制动总泵总成	1	见图4 序号1	N160-518000-000

图2 制动微动踏板总成
Fig. 2 Brake and inch pedal assy

CPCD20-XRW10B	CPCD20/25-XRW33B	CPCD20/25-XRW43B	CPCD20/25-XRW55B
CPCD20/25-XRW56B	CPQD20/25-XRW22B	CPQYD20/25-XRW22B	

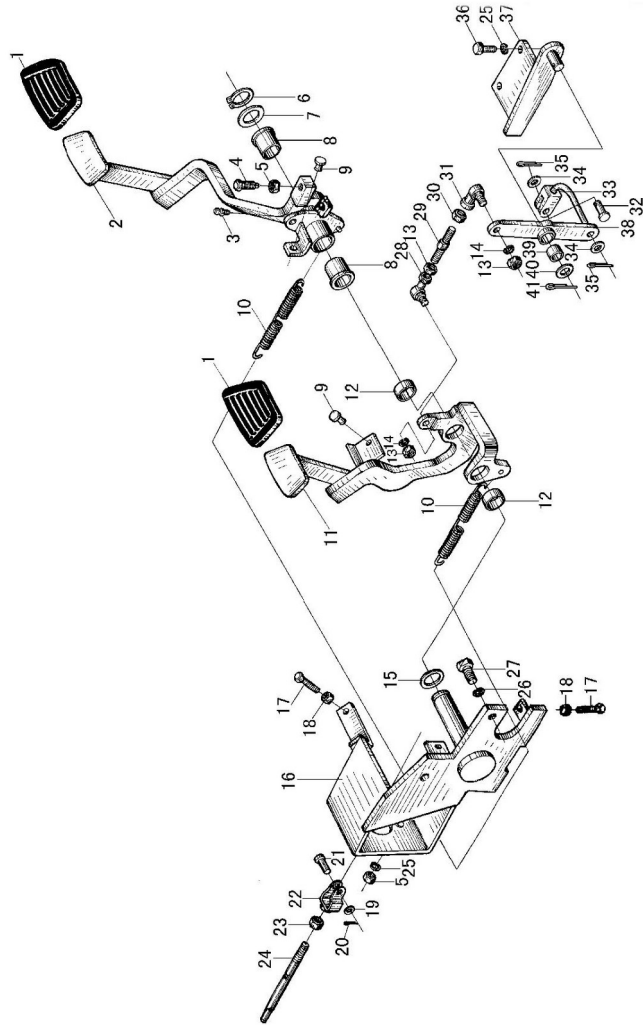
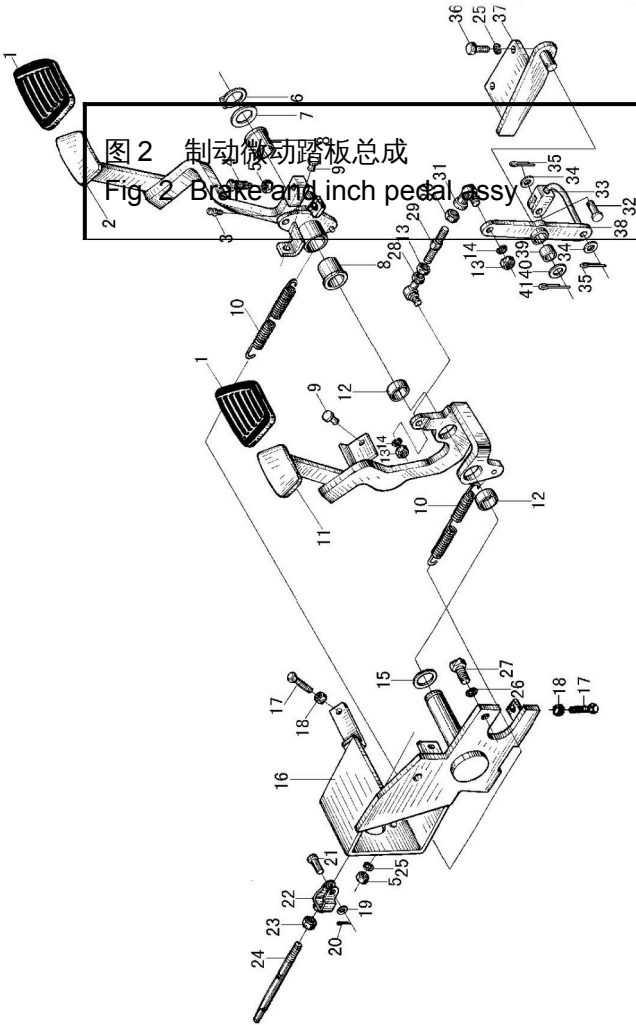



图2 制动微动踏板总成
Fig. 2 Brake and inch pedal assy

CPCD20-XRW10B
CPCD20/25-XRW56B

CPCD20/25-XRW33B
CPQD20/25-XRW22B

CPCD20/25-XRW43B
CPQYD20/25-XRW22B

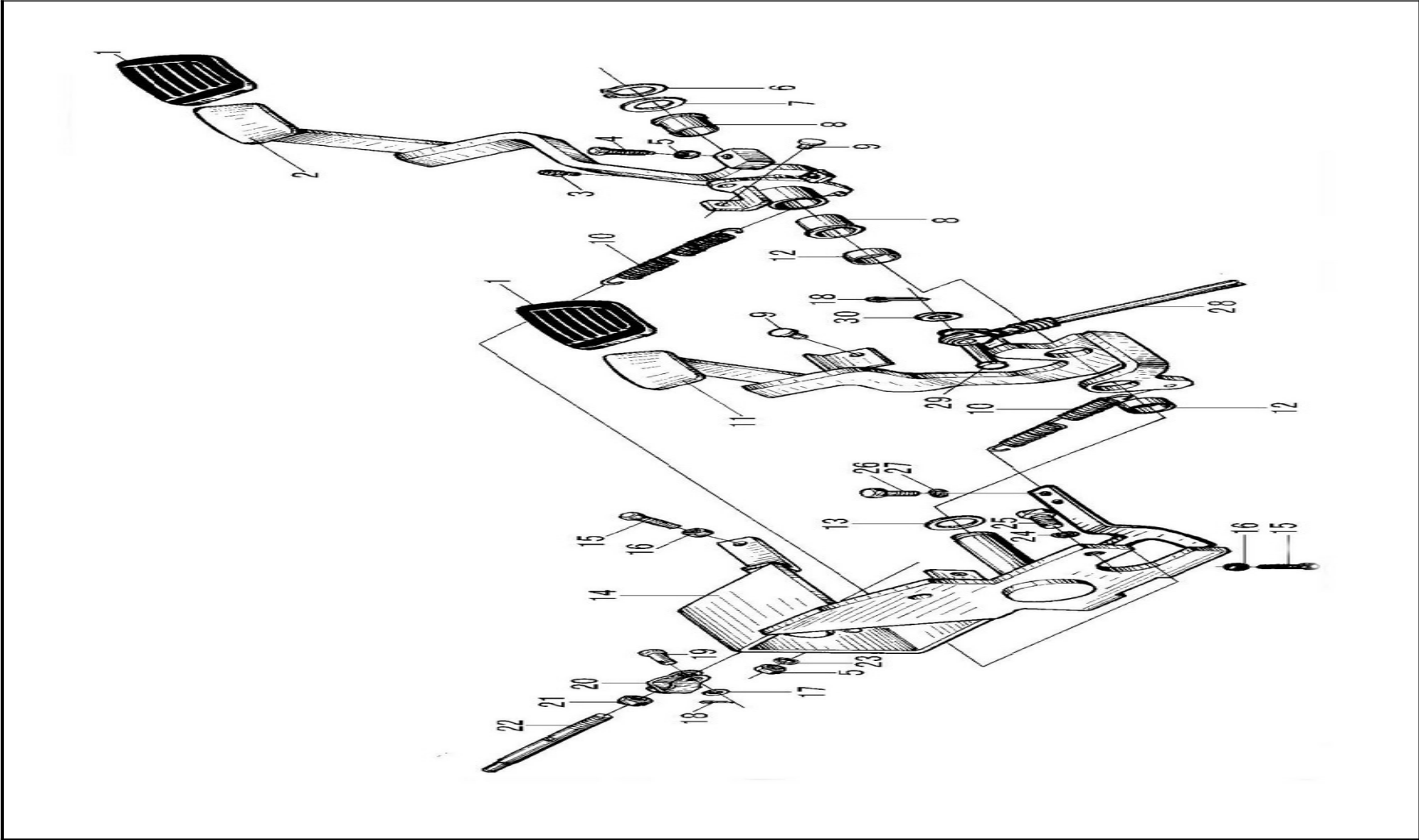
CPCD20/25-XRW55B

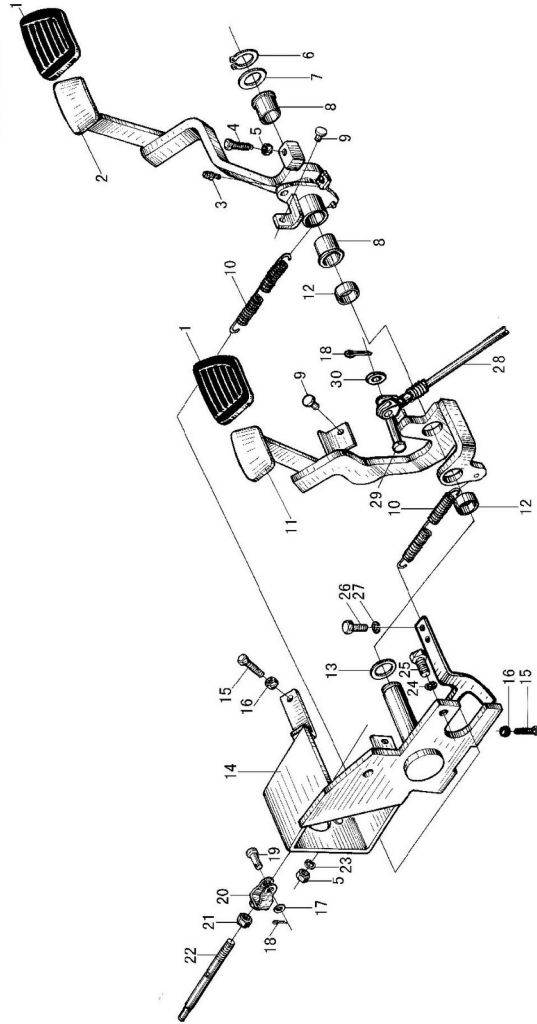

序号 Item No.	物料码 Part No.	名称 Description	数量 Qty.	备注或适用车型 Remarks or Serial No.	原物料码 Original Part No.
A	20510000081	制动微动踏板总成	1	包含/INC: 1-32	R561-510000-000
1	205100180001	踏板垫	2		N163-512001-000
2	205100170041	制动踏板	1		R561-515100-000
3	300170040003	油杯M6	1		G001152-006000-00
4	300010040013	螺钉M10×35	1		G005783-010035-00
5	300020010006	螺母M10	3		G006170-000010-00
6	300060030013	挡圈28	1		G0894P1-000028-00
7	205100090013	垫片	1		N163-510004-000
8	205100320007	套	2		N163-514001-000
9	205100270001	止推圈	2		N163-512002-000
10	205100050013	弹簧	2		N163-510003-000
11	205100170032	微动踏板	1		R561-514100-000
12	205100320009	套	2		N163-512003-000
13	205100090012	垫片	1		N163-510001-000
14	205100080006	底座	1		R561-511000-000

图 2 制动微动踏板总成 Fig. 2 Brake and inch pedal assy		CPCD20-XRW10B CPCD20/25-XRW56B	CPCD20/25-XRW33B CPQD20/25-XRW22B	CPCD20/25-XRW43B CPQYD20/25-XRW22B	CPCD20/25-XRW55B	
序号 Item	物料码 Part No.	名称 Description	数量 Qty.	备注或适用车型 Remarks or Serial No.	原物料码 Original Part No.	
15	300010040178	螺栓M8×30	2		G005783-008030-00	
16	300020010016	螺母M8	2		G006170-000008-00	
A2	205100230006	推杆总成	1	包含INC:17-22	N163-513000-000	
17	300030100010	垫圈8	1		G000848-000008-00	
18	205100160010	锁销1.6B	2		N163-513002-000	
19	300050040015	销轴B8×24	1		G000882-008024-00	
20	205100210011	推耳	1		N163-513100-000	
21	300020010006	螺母M10	1		G006170-000010-00	
22	205100220012	推杆	1		N163-513001-000	
23	300030010001	垫圈10	2		G000093-000010-00	
24	300030010002	垫圈12	2		G000093-000012-00	
25	300010060024	螺栓M12×1.25×25	2		G005786-012025-00	
26	300010040145	螺栓M6×12	2		G005783-006012-00	
27	300030010014	垫圈6	2		G000093-000006-00	

	28	205100100009	微动软轴	1		R561-512000-000
--	----	--------------	------	---	--	-----------------

 <p>图2 制动微动踏板总成 Fig. 2 Brake and inch pedal assy</p>	CPCD20-XRW10B	CPCD20/25-XRW33B	CPCD20/25-XRW43B	CPCD20/25-XRW55B		
	CPCD20/25-XRW56B	CPQD20/25-XRW22B	CPQYD20/25-XRW22B			
	序号 Item No.	物料码 Part No.	名称 Description	数量 Qty.	备注或适用车型 Remarks or Serial No.	原物料码 Original Part No.
	29	300050040036	销8×18	1		G000882-008018-01
	30	300030040014	垫圈8	1		G0097P1-000008-00
	31		微动推杆支架 Inching	1	见图12 序号A	
	32		制动总泵总成	1	见图4 序号1	

图3 制动离合踏板总成 Fig. 3 Brake clutch pedal assy	CPC20/25-XRG72	CPC20/25-XRG72J	CPC20/25-XRW10	CPC20/25-XRW55
---	----------------	-----------------	----------------	----------------



图3 制动离合踏板总成
Fig. 3 Brake clutch pedal assy

CPC20/25-XRG72

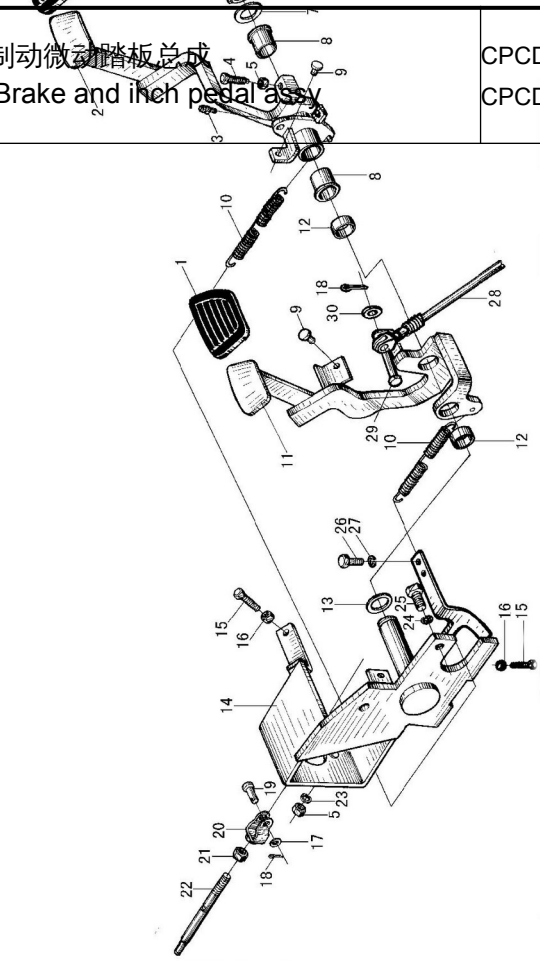
CPC20/25-XRG72J

CPC20/25-XRW10

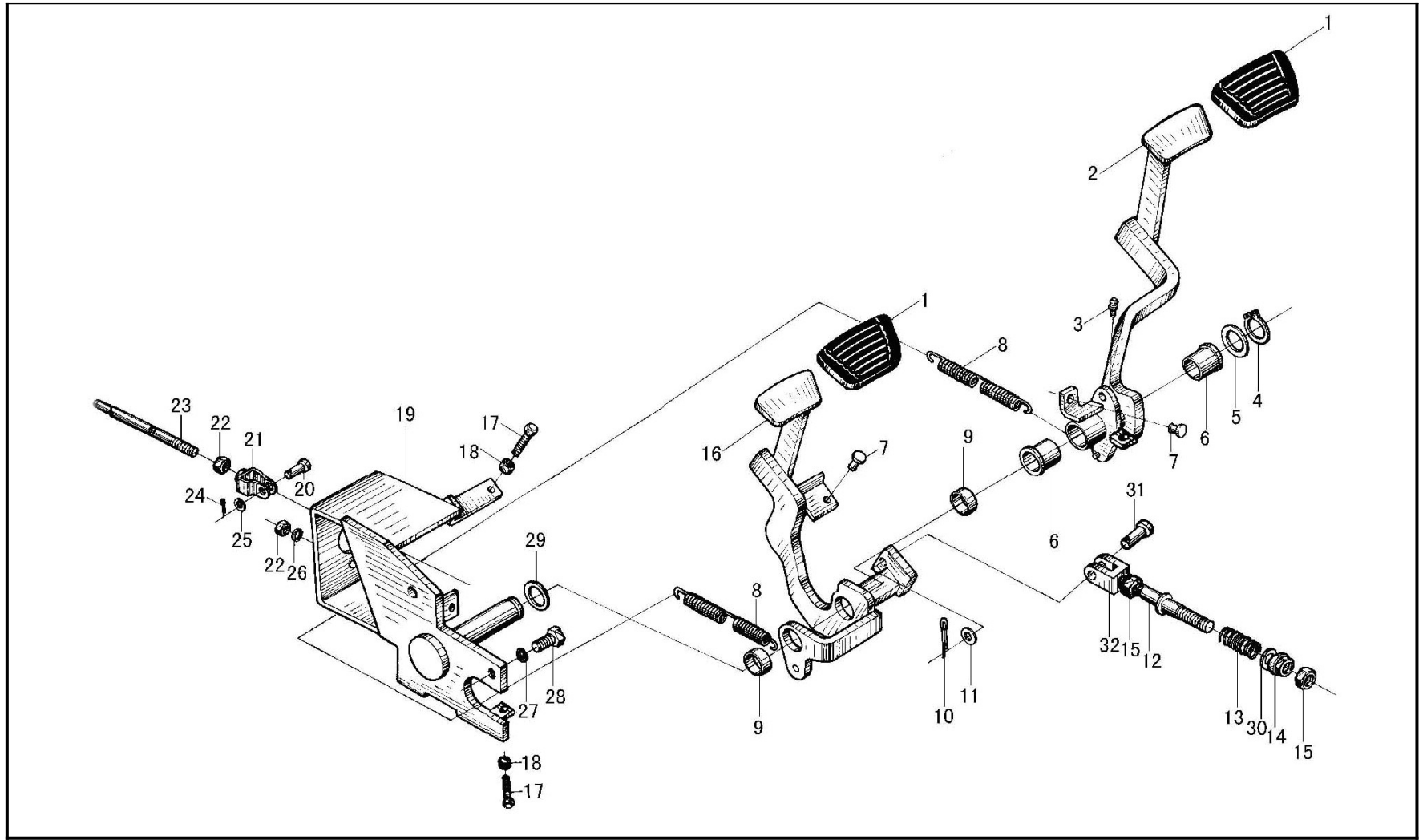
CPC20/25-XRW55

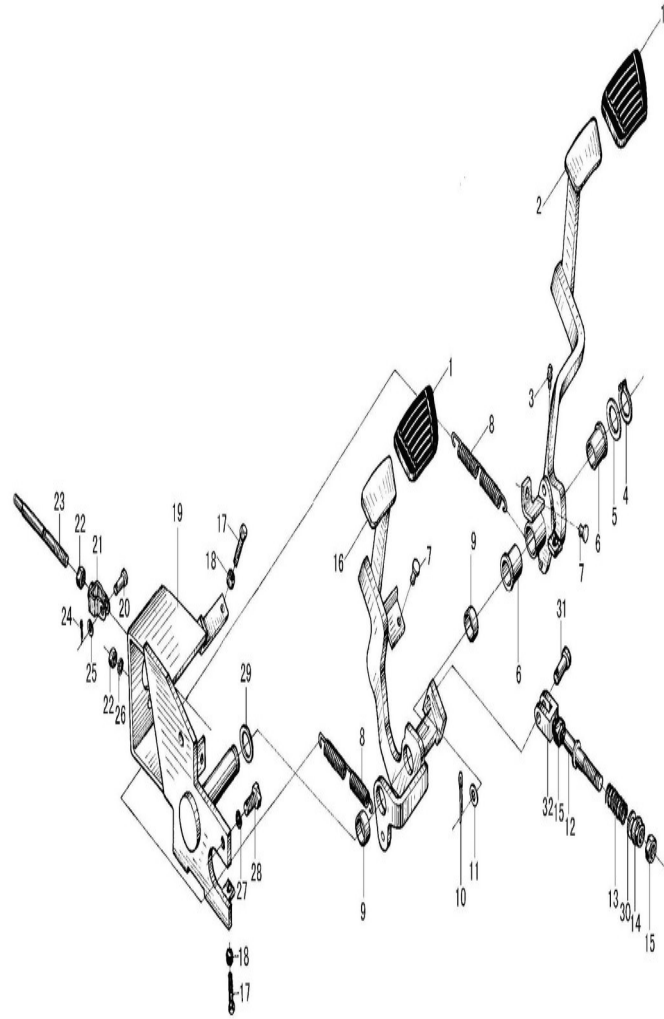

序号 Item	物料码 Part No.	名称 Description	数量 Qty.	备注或适用车型 Remarks or Serial No.	原物料码 Original Part No.
A1	20510000065	制动离合踏板总成	1		N150-510000-001
1	205100180001	踏板垫	2		N163-512001-000
2	205100170042	制动踏板	1		N150-512100-001
3	300170040003	油杯 M6	1		G001152-006000-00
4	300060030013	垫圈 28	1		G0894P1-000028-00
5	205100090013	垫片	1		N163-510004-000
6	205100320007	套	2		N163-514001-000
7	205100270001	止推圈	2		N163-512002-000
8	205100050013	弹簧	2		N163-510003-000
9	205100320009	套	2		N163-512003-000
10	205100160013	锁销1.8B	1		R441-500002-000
11	300030040002	垫圈10	1		G0097P1-000010-00
12	205100130013	拉杆	1		N150-513000-001
13	205100050019	压缩弹簧	1		N150-511002-000
14	310020050009	球形螺母	1		N150-511001-000

图 3 制动离合踏板总成 Fig. 3 Brake clutch pedal assy		CPC20/25-XRG72	CPC20/25-XRG72J	CPC20/25-XRW10	CPC20/25-XRW55	
序号 Item	代号 Part No	名称 Description	数量 Qty	备注或适用车型 Remarks or Serial No	原物料码 Original Part No	
15	300020020002	螺母M10×1	1		G006171-000010-00	
16	205100170022	离合踏板	1		N150-511100-001	
17	300010040178	螺栓M8×30	2		G005783-008030-00	
18	300020010016	螺母M8	2		G006170-000008-00	
19	205100080004	底座	1		N163-511000-001	
A2	205100230006	推杆总成	1	包含INC:20-25	N163-513000-000	
20	300050040038	销轴B8×24	1		G000882-008024-01	
21	205100210011	推耳	1		N163-513100-000	
22	300020010006	螺母M10	3		G006170-000010-00	
23	205100220012	推杆	1		N163-513001-000	
24	205100160010	锁销1.6B	1		N163-513002-000	
25	300030100010	垫圈8	1		G000848-000008-00	
26	300030010001	垫圈10	2		G000093-000010-00	
27	300030010002	垫圈12	2		G000093-000012-00	

<p>图4 制动总泵总成 Fig.4 Brake pump assy</p>	<p>除外/Except 全部车型All models of truck</p>					
	<p>序号 Item No.</p>	<p>物料码 Part No.</p>	<p>名称 Description</p>	<p>数量 Qty.</p>	<p>备注或适用车型 Remarks Or Special No.</p>	<p>原物料码 Original Part No.</p>
	1	205100310015	制动总泵总成	1		N160-518000-000
	2	206300230048	右制动油管	1		N163-550200-001
	3	206300230087	左制动油管	1		N163-550100-001

图5 油门操纵总成(电子) Fig.5 Throttle control assy (Electron)	CPCD20/25-XRG71	CPCD20/25-XRG72	CPCD20/25-XRG72F	CPC20/25-XRG72		
	CPCD20/25-XRG72J	CPC20/25-XRG72J	CPCD20/25-XRW43	CPCD20/25-XRW43B		
	CPCD20/25-XRW43F	CPCD20/25-XRW92F	CPCD20/25-XRG72JF			
	序号 Item No.	物料码 Part No.	名称 Description	数量 Qty.	备注或适用车型 Remarks Or Serial No.	原物料码 Original Part No.
	1	207900310005	电子油门踏板	1		XB455-700002-000
	2	300010040169	螺栓M8×16	3		G005783-008016-00
	3	300030010015	垫圈8	3		G000093-000008-00

图6 油门操纵总成 Fig.6 Throttle control assy	CPCD20-XRW10	CPCD20/25-XRW10B	CPCD20/25-XRW10F	CPC20/25-XRW10		
	CPCD20/25-XRW33B	CPCD20/25-XRW33F	CPCD20/25-XRW73	CPCD20/25-XRW55B		
	CPCD20/25-XRW55F	CPC20/25-XRW55	CPCD20/25-XRW56	CPCD20/25-XRW56B		
	序号 Item	物料码 Part No.	名称 Description	数量 Qty.	备注或适用车型 Remarks Or Serial No.	原物料码 Original Part No.
	1	205200080017	油门踏板	1		XF250-520001-000
	2	300060060004	挡圈6	1		G000896-000006-00
	3	205200180014	支架	1		XF250-520005-000
	4	300010040148	螺栓M6×16	2		G005783-006016-00
	5	300030010014	垫圈6	4/6	6个	G000093-000006-00
	6	205200200021	销轴	1		XF250-520002-000
	7	300010040169	螺栓M8×16	2		G005783-008016-00
	8	300030010015	垫圈8	4		G000093-000008-00
	9	300050040027	销轴B6×16	1		G000882-006016-01
10	300050010015	销2×12	1		G000091-002012-00	

	11	205200050009	连杆	1		XF250-521000-000
	12	202200090002	限位螺栓	1		15PH-500001
	13	300020010016	螺母M8	1		G006170-000008-00
	14	300020010005	螺母M6	3/4	4个	G006170-000006-00
	15	205200070001	锁销6	1		XF250-520006-G00

图6 油门操纵总成 Fig.6 Throttle control assy	CPCD20-XRW10	CPCD20/25-XRW10B	CPCD20/25-XRW10F	CPC20/25-XRW10		
	CPCD20/25-XRW33B	CPCD20/25-XRW33F	CPCD20/25-XRW73	CPCD20/25-XRW55B		
	CPCD20/25-XRW55F	CPC20/25-XRW55	CPCD20/25-XRW56	CPCD20/25-XRW56B		
	序号 Item	物料码 Part No.	名称 Description	数量 Qty.	备注或适用车型 Remarks Or Serial No.	原物料码 Original Part No.
	16	205200120010	摇臂	1		XF250-524000-000
	17	300050090025	销5×40	1		G000879-005040-00
	18	205200060002	扭簧	1		XF250-520004-000
	19	205200010002	衬套	2		XF250-520003-000
	20	300010040155	螺栓M6×30	1		G005783-006030-00
	21	205200020126	支架	1		XR312-522000-000
	22	205200140101	油门拉线	1		XF308-521000-000
	22	205200140034	油门拉线	1		XF250-523000-000
	22	205200140036	油门拉线	1		XF255-521000-000

	22	205200140103	油门拉线	1	~2019.05.11	XF3012-521000-000
	22	205200140160	油门拉线	1		XF2519-511000-000
	22	205200140103	油门拉线	1	~2019.05.11	XF3012-521000-000
	22	205200140037	油门拉线	1	~2019.05.11	XF155-521000-000
	23	205200040009	拉线挂销	1		N121-510001-000
	23	205200040012	拉线挂销	1		GR501-520001-000

	CPCD20-XRW10		CPCD20/25-XRW10B	CPCD20/25-XRW10F	CPC20/25-XRW10	
	CPCD20/25-XRW33B		CPCD20/25-XRW33F	CPCD20/25-XRW73	CPCD20/25-XRW55B	
	CPCD20/25-XRW55F		CPC20/25-XRW55	CPCD20/25-XRW56	CPCD20/25-XRW56B	
	图6 油门操纵总成 Fig.6 Throttle control assembly					
	序号 Item No.	物料码 Part No.	名称 Description	数量 Qty.	备注或适用车型 Remarks or Serial No.	原物料码 Original Part No.
	24	300030040013	垫圈6	1/3	3个	G0097P1-000006-00
	25	300060060007	挡圈4	1		G000896-000004-00
	26	300010040173	螺栓M8×20	2		G005783-008020-00
	27	300010040150	螺栓M6×18	2		G005783-006018-00
	28	205200140098	熄火拉线总成	1		A300-524000-000
	29	205100020297	支架	1		R968-510002-000
	30	300030040014	垫圈8	2		G0097P1-000008-00

图7 油门操纵总成 Fig.7 Throttle control assy	CPQD20/25-XRW22 CPQD20/25-XRW22B CPQD20/25-XRW22F CPQYD20/25-XRW22F CPYD20/25-XRW52F CPQYD20/25-XRW22B					
	序号 Item	代号 Part No	名称 Description	数量 Qty	备注或适用车型 Remarks or Serial No	原物料码 Original Part No
	1	205200080017	油门踏板	1		XF250-520001-000
	2	300060060004	挡圈6	1		G000896-000006-00
	3	205200180014	支架	1		XF250-520005-000
	4	300010040148	螺栓M6×16	2		G005783-006016-00
	5	300030010014	垫圈6	3		G000093-000006-00
	6	205200200021	销轴	1		XF250-520002-000
	7	300010040169	螺栓M8×16	2		G005783-008016-00

	8	300030010015	垫圈8	2		G000093-000008-00
	9	300050040011	销轴6×16	1		G000882-006016-00
	10	300050010015	销2×12	1		G000091-002012-00
	11	205200050009	连杆	1		XF250-521000-000
	12	202200090002	限位螺栓	1		15PH-500001
	13	300020010016	螺母M8	1		G006170-000008-00
	14	300020010005	螺母M6	3		G006170-000006-00
	15	205200070001	锁销6	1		XF250-520006-G00

	图7 油门操纵总成		CPQD20/25-XRW22	CPQD20/25-XRW22B	CPQYD20/25-XRW22	CPQD20/25-XRW22F	
	Fig.7 Throttle control assy		CPQYD20/25-XRW22F	CPYD20/25-XRW52F	CPQYD20/25-XRW22B		
	序号	代号	名称	数量	备注或适用车型	原物料码	
	Item	Part No	Description	Qty	Remarks or Serial No	Original Part No	
	16	205200120010	摇臂	1		XF250-524000-000	
	17	300050090025	销5×40	1		G000879-005040-00	
	18	205200060002	扭簧	1		XF250-520004-000	
	19	205200010002	衬套	2		XF250-520003-000	
20	300010040155	螺栓M6×30	1		G005783-006030-00		
21	205200020126	支架	1		XR312-522000-000		

	22	205200140040	油门拉线	1		XF251-523000-000

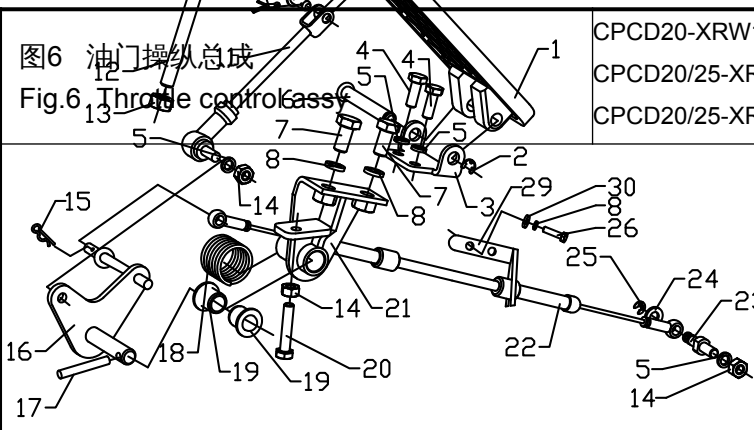
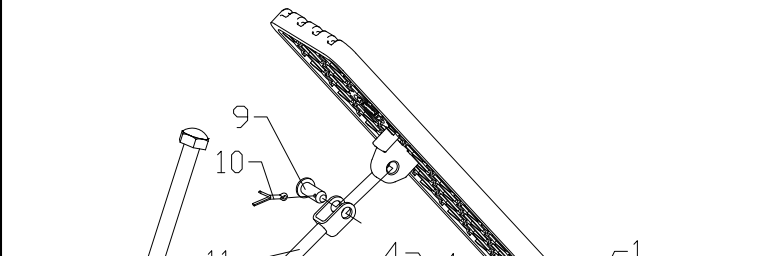
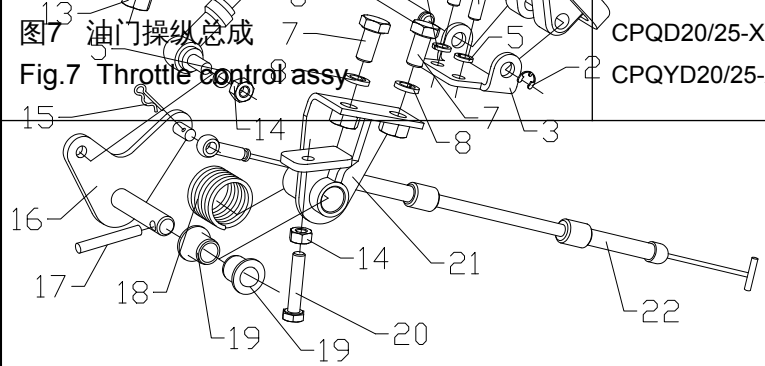
图 8 换档操纵总成 Fig. 8 Change over control assy		CPC20/25-XRG72	CPC20/25-XRG72J	CPC20/25-XRW10	CPC20/25-XRW55	
	序号 Item	代号 Part No	名称 Description	数量 Qty	备注或适用车型 Remarks or Serial No	原物料码 Original Part No
	A	205400000011	换档操纵总成 Change	1		N150-530000-000
	1	205400030040	换向手柄	1		N150-530100-000
	2	205400030034	换档手柄	1		N150-530200-000
	3	205400030025	换档手把	1		N150-530002-000
	4	205400030039	换向手把	1		N150-530001-000

	5	300030100010	垫圈8	2		G000848-000008-00
	6	300030010015	垫圈8	2		G000093-000008-00
	7	300010030182	螺栓M8×35	2		G005782-008035-00

图9 手制动操纵 Fig.9 Hand brake control		全部车型 All models of truck				
	序号 Item	代号 Part No	名称 Description	数量 Qty	备注或适用车型 Remarks or Serial No	原物料码 Original Part No
	A	205500000091	手制动操纵总成			XR310-530000-000
	1	205500020007	驻车制动器Device ass	1	压钮Button	NC9321-531000-000
	2	300010040005	螺栓M10×20	2		G005783-010020-00
	3	300030010001	垫圈10	6		G000093-000010-00

	4	310040010071	管夹	1		N163-540001-000
	5	300010040169	螺栓M8×16	1		G005783-008016-00
	6	300030010015	垫圈8	1		G000093-000008-00
	7	310040010072	管夹	4		N163-540002-000
	8	300010040004	螺栓M10×16	4		G005783-010016-00

图 10 制动微动踏板总成 Fig.10 Brake and inching pedal assy	CPCD20/25-XRG72F	CPCD20/25-XRW10F	CPCD20/25-XRW33F			
	CPCD20/25-XRW43F	CPCD20/25-XRW55F	CPCD20/25-XRW56F			
	CPCD20/25-XRW92F	CPQD20/25-XRW22F	CPQYD20/25-XRW22F			
	序号 Item	代号 Part No	名称 Description	数量 Qty	备注或适用车型 Remarks or Serial No	原物料码 Original Part No
	A	205100000396	制动微动踏板总成	1	包含/INC: 1-32	XRF310-510000-000
	1	205100180001	踏板垫	2		N163-512001-000
	2	205100260131	制动踏板	1		XRF310-513100-000

4	300010040011	螺栓M10×30	1		G005783-010030-00
5	300020010006	螺母M10	2		G006170-000010-00
6	300060030013	挡圈28	1		G0894P1-000028-00
7	205100090013	垫片	1		N163-510004-000
8	205100320007	套	2		N163-514001-000
9	300030040014	垫圈8	1		G0097P1-000008-00
10	205100050013	弹簧	2		N163-510003-000
11	205100260130	微动踏板	1		XRF310-512100-000
12	205100320009	套	2		N163-512003-000
13	205100090012	垫片	1		N163-510001-000
14	205100080042	底座	1		XRF310-511000-000

图 10 制动微动踏板总成 Fig.10 Brake and inching pedal assy	CPCD20/25-XRG72F	CPCD20/25-XRW10F	CPCD20/25-XRW33F			
	CPCD20/25-XRW43F	CPCD20/25-XRW55F	CPCD20/25-XRW56F			
	CPCD20/25-XRW92F	CPQD20/25-XRW22F	CPQYD20/25-XRW22F			
	序号 Item	代号 Part No	名称 Description	数量 Qty	备注或适用车型 Remarks or Serial No	原物料码 Original Part No
	15	300010040178	螺栓M8×30	2		G005783-008030-00
	16	300020010016	螺母M8	1		G006170-000008-00

	A2	205100230006	推杆总成	1		N163-513000-000
	17	300030100010	垫圈8	1		G000848-000008-00
	18	205100160010	锁销1.6B	3		N163-513002-000
	19	300050040015	销轴B8×24	1		G000882-008024-00
	20	205100210011	推耳	1		N163-513100-000
	21	300020010006	螺母M10	1		G006170-000010-00
	22	205100220012	推杆	1		N163-513001-000
	23	300030010001	垫圈10	2		G000093-000010-00
	24	300030010002	垫圈12	2		G000093-000012-00
	25	300010060024	螺栓M12×1.25×25	2		G005786-012025-00
	26	300010040145	螺栓M6×12	2		G005783-006012-00
	27	300030010014	垫圈6	2		G000093-000006-00
	28	205100100078	微动拉线总成	1		XRF310-514000-000

图 10 制动微动踏板总成 Fig.10 Brake and inching pedal assy	CPCD20/25-XRG72F	CPCD20/25-XRW10F	CPCD20/25-XRW33F			
	CPCD20/25-XRW43F	CPCD20/25-XRW55F	CPCD20/25-XRW56F			
	CPCD20/25-XRW92F	CPQD20/25-XRW22F	CPQYD20/25-XRW22F			
	序号 Item	代号 Part No	名称 Description	数量 Qty	备注或适用车型 Remarks or Serial No	原物料码 Original Part No
	29	300050040036	销轴B8×18	1		G000882-008018-01

	30	300050040065	销轴B5×16	1		G000882-005016-01
	31	300030040012	垫圈5	1		G0097P1-000005-00
	32	300050010015	销2×12	1		G000091-002012-00
	33	300020300002	螺母M10	1		G006172-000010-00
	34	300020300006	螺母M8	1		G006172-000008-00
			制动总泵总成	1	见图11 序号1	

图11 制动总泵总成 Fig.11 Brake pump assy	CPCD20/25-XRG72F	CPCD20/25-XRW10F	CPCD20/25-XRW33F			
	CPCD20/25-XRW43F	CPCD20/25-XRW55F	CPCD20/25-XRW56F			
	CPCD20/25-XRW92F	CPQD20/25-XRW22F	CPQYD20/25-XRW22F			
	序号 Item	代号 Part No	名称 Description	数量 Qty	备注或适用车型 Remarks or Serial No	原物料码 Original Part No

	1	205100310015	制动总泵总成	1		N160-518000-000
	A1	206300230344	右制动油管	1	包含/INC:2-3	XRF310-550200-000
	2	206300230252	右制动油管	1		AE310-520200-000
	3	206300060004	管套	3		N163-550201-000
	4	206300230278	左制动油管	1		AE310-520100-000

<p>图 12 微动推杆支架 Fig. 12 Inching Budge push-rod stents</p>	<p>CPCD20/25-XRW10B</p>	<p>CPCD20/25XRW33B</p>	<p>CPQD20/25-XRW22B</p>	<p>CPQYD20/25-XRW22B</p>	
--	-------------------------	------------------------	-------------------------	--------------------------	--

序号 Item	代号 Part No	名称 Description	数量 Qty	备注或适用车型 Remarks or Serial No	原物料码 Original Part No
A	205100020038	微动推杆支架 Inching	1	INC:1-5	R561-513000-000
1	205100020034	固定支架	1		R561-513100-000
2	205100350187	上板	1		R561-513200-000
3	205100040050	复合衬套 0806	1		R561-513002-G00
4	205100350192	下板	1		R561-513001-000
5	300050090013	销3×20	1		GT879P1-003020-00
6	205100050013	弹簧	1		N163-510003-000
7	205100070012	微动弹簧支撑板	1		R561-510001-000

