

第七部分 电气系统目录

PART VII Electrical system contents

CPCD10/15/18-XRG71	CPC10/15/18-XRG71J	CPCD10/15/18-XRG71F	CPC10/15/18-XRG71	CPCD10/15/18-XRG71J
CPCD15/18-XRW10	CPCD15/18-XRW10 B	CPCD15/18-XRW10 F	CPC15/18-XRW10	CPCD15/18-XRW32B
CPCD15/18-XRW32F	CPCD15-XRW43	CPQD15/18-XRW21	CPQYD15-XRW21	CPCD15/18-XRW91F
CPQD15/18-XRW21F	CPQYD15-XRW21F	CPYD15/18-XRW51F		

序号 Item	名称 Description	适用车型 Serial No.	页码 Page
图 I Fig.I	前灯总成 front lamps assy	全部车型 All models of truck	7-1
图 II Fig.II	后灯总成 rear lamps assy	全部车型 All models of truck	7-2
图 III Fig.III	喇叭 Horn	全部车型 All models of truck	7-3
图 IV Fig.IV	组合开关总成 Combination Switch assy	全部车型 All models of truck	7-4
图 V Fig.V	仪表总成 Instrument assy	全部车型 All models of truck	7-5
图 VI Fig.VI	四卡翘板开关 4-Rocker Switches	全部车型(选配) All models of truck (Optional)	7-6

图VII Fig.VII	手刹开关总成 Hand-brake switch assy	全部车型(选配) All models of truck (Optional)	7-7
图VIII Fig.VIII	控制盒总成 Control box assy	除外/Except 全部车型All models of truck	7-8
图IX Fig.IX	控制盒总成 Control box assy		7-9

序号 Item	名称 Description	适用车型 Serial No.	页码 Page
图X Fig. X	转向灯开关 Steering lamp switch		7-10
图XI Fig. XI	控制盒总成 Control box assy		7-11
图XII Fig.XII	智能安装模块 Intelligent installation module	全部车型 All models of truck	7-12
图1 Fig. 1	电气系统 Electrical system		7-13
图2 Fig. 2	电气系统 Electrical system		7-17
图3 Fig.3	电气系统 Electrical system		7-21
图4 Fig.4	电气系统 Electrical system		7-25
图5 Fig.5	电气系统 Electrical system		7-30
图6 Fig.6	电气系统 Electrical system		

图 I 前灯总成
Fig.I Front lamps assy

全部车型
All models of truck

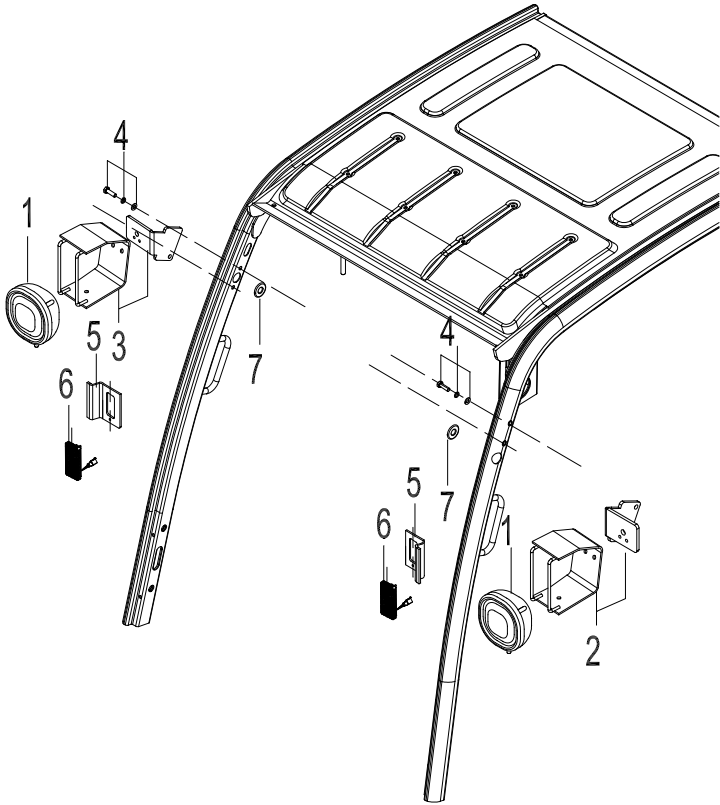

序号 Item No.	物料码 Part No.	名称 Description	数量 Qty.	备注或适用车型 Remarks Or Special No.	原物料码 Original Part No.
1	207600010316	前大灯	2		XR310-760100-000
2	207900210419	左前大灯灯架总成	1		XF250-761000-620
3	207900210412	右前大灯灯架总成	1		XF250-762000-620
4	300010210001	螺栓组合件M8×16	8		G907414-008016-00
5	207900201256	前小灯支架	2		XR310-763000-000
6	207600050069	前小灯	2		XR310-760200-000
7	207900060011	前灯线护套	2		N163-700002-000

图IV 组合开关总成 Fig.IV Combination Switch assy	全部车型 All models of truck					
	序号 Item	物料码 Code No	名称 Description	数量 Qty	备注或适用车型 Remarks Or Serial No	原物料码 Original Part No
	A	207200020024	组合开关Combination	1		XF250-705000-000
	1	207900070047	六线复合插头	1		DJ7061-6.3-10-G00
	2	207900070049	六线复合插座	1		DJ7061-6.3-20-G00

图V 仪表总成 Fig.V Instrument assy	全部车型 All models of truck					
	序号 Item	物料码 Code No	名称 Description	数量 Qty	备注或适用车型 Remarks Or Serial No	原物料码 Original Part No
	A	207900050174	仪表总成 Instrument	1		XR310-740000-000

图 VI 四卡翘板开关 Fig.VI 4-Rocker Switches	全部车型(选配) All models of truck (Optional)					
	序号 Item	物料码 Part NO	名称 Description	数量 Qty	备注或适用车型 Remarks or Serial NO	原物料码 Original Part No
	1	207200060062	风扇开关	1		MB250-700508-W00
	2	207200010038	警灯开关	1		MB250-700502-W00
	3	207200010034	后工作灯开关	1		MB250-700503-W00
	4		后除霜开关	1	无此零件	
	5	207900080034	盖板	1		MB250-700501-W00
	6	207200060065	前雨刮洗涤器开关 wash	1		MB250-700506-W00
	7		后雨刮器及洗涤器开关	1	无此零件	
	8	207200060067	液化气/汽油 开关	1		MB250-700504-W00
	9	207200060064	前雨刮器开关	1		MB250-700505-W00



图 VII 手刹开关总成
Fig.VII Hand-brake switch assy

全部车型(选配)
All models of truck (Optional)

序号 Item	物料码 Part NO	名称 Description	数量 Qty	备注或适用车型 Remarks or Serial NO	原物料码 Original Part No
A1	207200080030	手刹开关总成	1		NC9419-703000-800
1	207100120026	手刹开关线束	1		R960-703100-800
2	300040070031	螺钉M4×25	2		G000818-004025-00
3	300030010012	垫圈4	2		G000093-000004-00
4	300030040011	垫圈4	2		G0097P1-000004-00
5	207200080032	微动开关	1		NC9419-703001-800

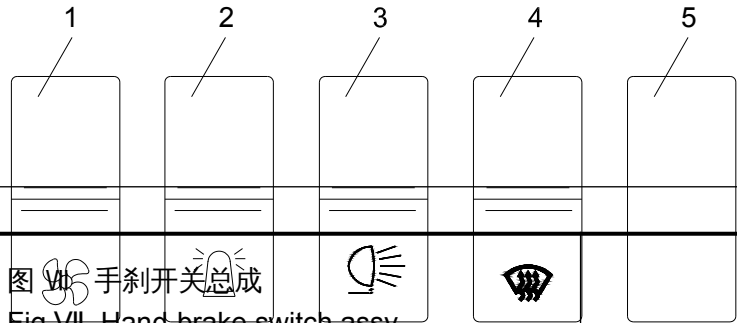

图 VIII 控制盒总成 Fig.VIII Control box assy	除外/Except 全部车型All models of truck					
	序号 Item	物料码 Part No.	名称 Description	数量 Qty.	备注或适用车型 Remarks Or Serial No.	原物料码 Original Part No.
	A1	207400010213	控制盒总成	1		XR310-706000-000
	1	207400030073	预热继电器	2		R450-706001-001
	2	207400020002	电子闪光器	1		XF250-706003-000
	4	207900080058	拨片器	1		A300-704003-000
	5	207400030062	通用继电器	6		XB450-706003-000
	6	207400070112	控制盒标签	1	English	XR310-706001-000
	6	207400070123	控制盒标签	1	中文	XR310-706002-000

	7	NO PART NO.	十六线复合插头	1		
	8	NO PART NO.	十六线复合插头	1		
	9	NO PART NO.	七线复合插头	1		
	10	NO PART NO.	9.5二线插头	1		
	11	810700000002	保险丝片 10A	4		XR310-706001-W00-10A
	12	810700000003	保险丝片 15A	3		XR310-706001-W00-15A
	13	810700000004	保险丝片 20A	2		XR310-706001-W00-20A
	14	810700000005	保险丝片 30A	1		XR310-706001-W00-30A

图 IX 控制盒总成 Fig.IX Control box assy						
	序号 Item	物料码 Part No.	名称 Description	数量 Qty.	备注或适用车型 Remarks or Serial No.	原物料码 Original Part No.
	A1	207400010216	控制盒总成	1		XR311-706000-000
	1	207400030073	预热继电器	1		R450-706001-001
	2	207400020002	电子闪光器	1		XF250-706003-000
	4	207900080058	拨片器	1		A300-704003-000
	5	207400030062	通用继电器	6		XB450-706003-000
	6	207400070124	控制盒标签	1	English	XR311-706001-000

	6	207400070125	控制盒标签	1	中文	XR311-706002-000
	7	NO PART NO.	十六线复合插头	1		
	8	NO PART NO.	十六线复合插头	1		
	9	NO PART NO.	七线复合插头	1		
	10	NO PART NO.	9.5二线插头	1		
	11	810700000002	保险丝片 10A	6		XR310-706001-W00-10A
	12	810700000003	保险丝片 15A	3		XR310-706001-W00-15A
	13	810700000004	保险丝片 20A	2		XR310-706001-W00-20A
14	810700000005	保险丝片 30A	1		XR310-706001-W00-30A	

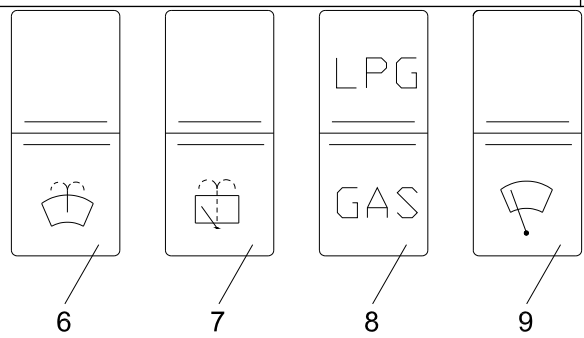
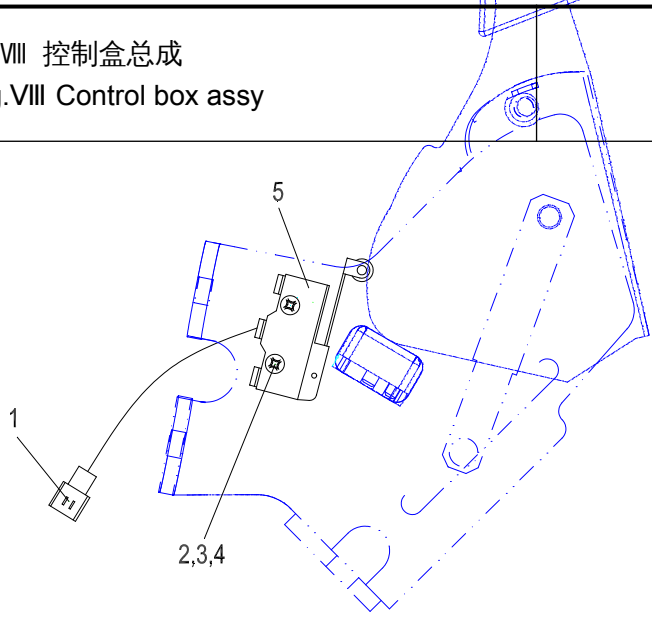
图X 转向灯开关 Fig. X Steering lamp switch	CPC10/15/18-XRG71J CPC10/15/18-XRG71 CPC15/18-XRW10					
	序号 Item	物料码 Code No	名称 Description	数量 Qty	备注或适用车型 Remarks Or Serial No	原物料码 Original Part No
	A	207200010056	转向灯开关Steering lamp	1		XR300-705000-000
	1	207900070047	六线复合插头	1		DJ7061-6.3-10-G00
	2	207900070049	六线复合插座	1		DJ7061-6.3-20-G00

图 XI 控制盒总成 Fig. XI Control box assy	CPC10/15/18-XRG71J CPC10/15/18-XRG71 CPC15/18-XRW10					
	序号 Item	物料码 Part No.	名称 Description	数量 Qty.	备注或适用车型 Remarks Or Serial No.	原物料码 Original Part No.
	A	207400010239	控制盒总成	1		XR300-706000-000
	1	207900080058	拨片器	1		A300-704003-000
	2	207400030073	预热继电器	2		R450-706001-001
	3	207400020002	电子闪光器	1		XF250-706003-000

	4	207400030062	通用继电器	3		XB450-706003-000
	5	810700000002	保险丝片 10A	4		XR310-706001-W00-10A
	5	810700000003	保险丝片 15A.	3		XR310-706001-W00-15A
	5	810700000004	保险丝片 20A	2		XR310-706001-W00-20A
	5	810700000005	保险丝片 30A	1		XR310-706001-W00-30A
	6	207400070129	控制盒标签	1	English	XR300-706001-000
	6	207400070130	控制盒标签	1	中文	XR300-706002-000

图XII 智能安装模块 Fig.XII Intelligent installation module		全部车型 All models of truck				
序号 Item	物料码 Part No.	名称 Description	数量 Qty.	备注或适用车型 Remarks Or Serial No.	原物料码 Original Part No.	
A	207400080716	智能模块Intelligent	1	包含/INC:1-5	XR310-743000-500	
1	300030010012	垫圈4	4		G000093-000004-00	
2	300030100007	垫圈4	4		G000848-000004-00	

	3	300040170010	螺钉M4x12	4		G000067-004012-00
	4	300020010014	螺母M4	4		G006170-000004-00
	5	207400080589	智能控制器	1		AP250-710002-510
	6	207100150155	智能控制线束Intellige	1		XR310-744000-500

图1 电气系统 Fig.1 Electrical system	CPCD10/15/18-XRG71 CPCD10/15/18-XRG71J
------------------------------------	---



图1 电气系统
Fig.1 Electrical system

CPCD10/15/18-XRG71 CPCD10/15/18-XRG71J

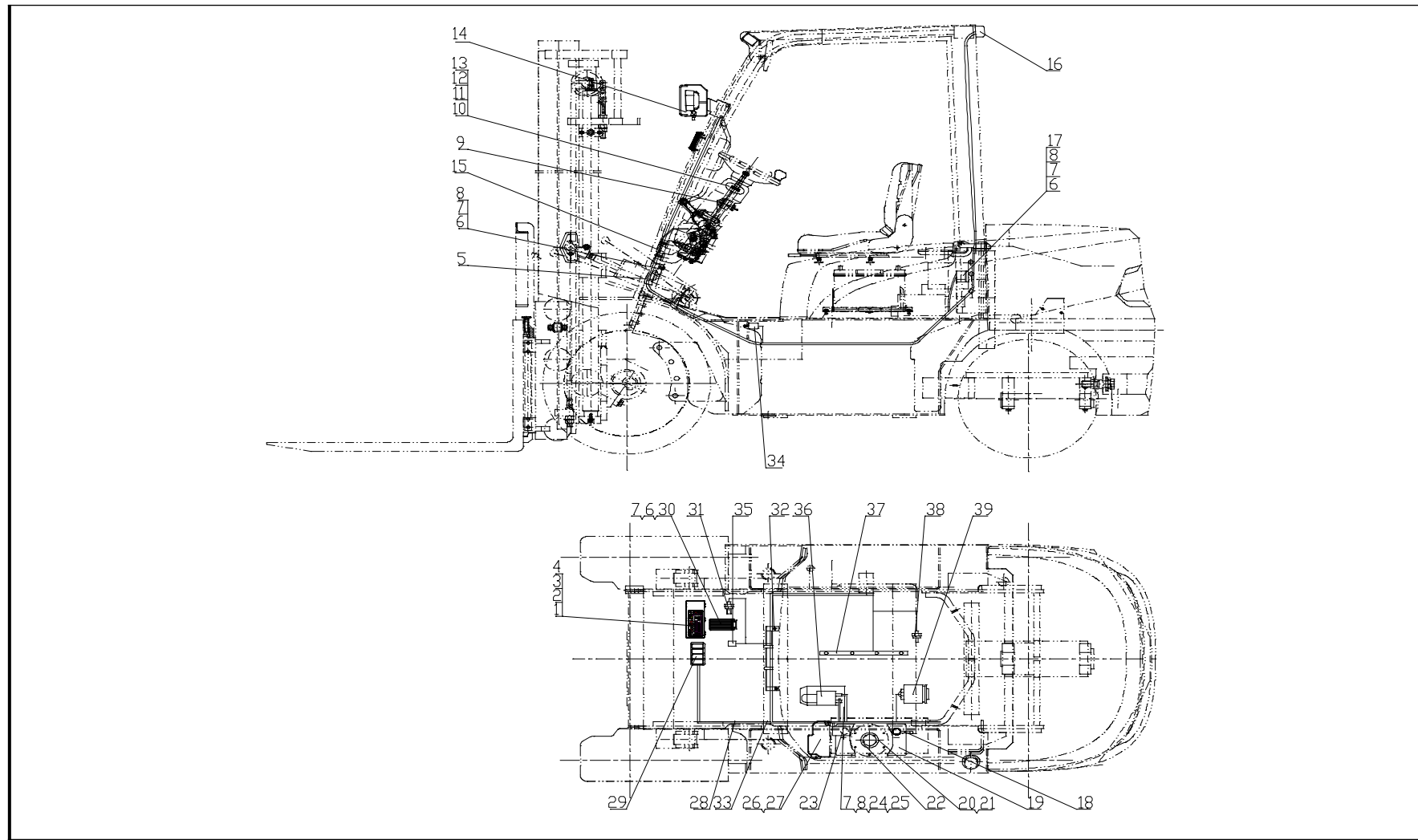
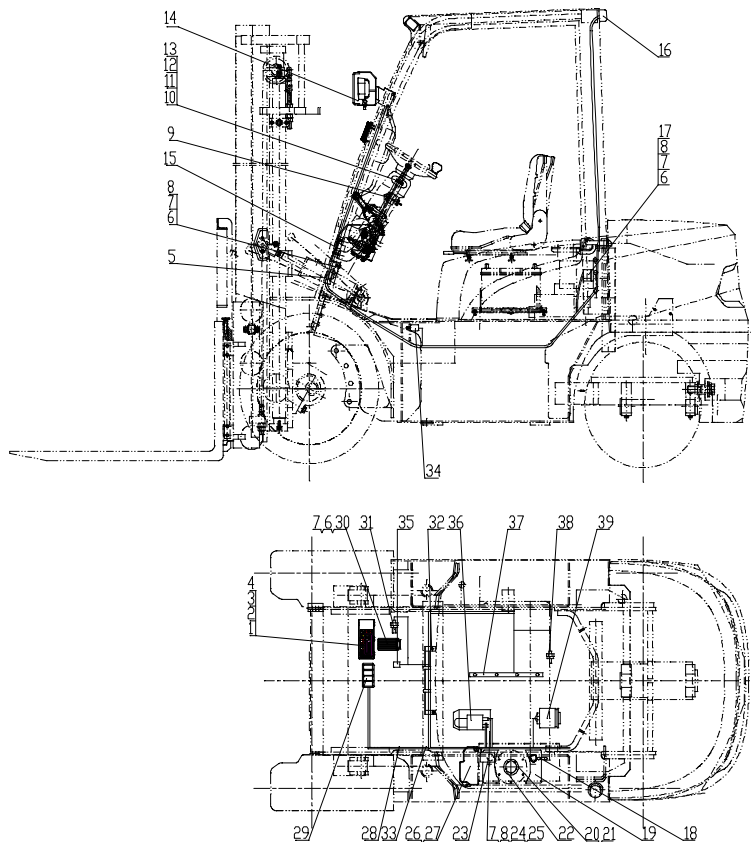

序号 Item	物料码 Part No.	名称 Description	数量 Qty.	备注或适用车型 Remarks Or Serial No.	原物料码 Original Part No.
1	207900050174	仪表总成	1	见图 V ,See Fig.V	XR310-740000-000
2	300040070036	螺钉M4×12	4		G000818-004012-00
3	300030040011	垫圈4	4		G0097P1-000004-00
4	300030010012	垫圈4	4		G000093-000004-00
5	207900130006	喇叭	1	见图 III ,See Fig.III	N163-700009-000
6	300010120005	螺栓M8×16	5		G0029P2-008016-00
7	300030010015	垫圈8	7		G000093-000008-00
8	300030040014	垫圈8	4		G0097P1-000008-00
9	207200030016	预热起动开关	1		R450-740200-000
10	207200020024	组合开关总Combination	1	见图 IV ,See Fig.IV	XF250-705000-000
11	300030010013	垫圈5	4		G000093-000005-00
12	300030040012	垫圈5	4		G0097P1-000005-00
13	300040070007	螺钉M5×10	4		G000818-005010-00
14	207600020169	前灯总成	1	见图 I ,See Fig.I	XR310-760000-000
15	207900080028	扎带	5		XF250-700001-G00

图1 电气系统
Fig.1 Electrical system

CPCD10/15/18-XRG71 CPCD10/15/18-XRG71J

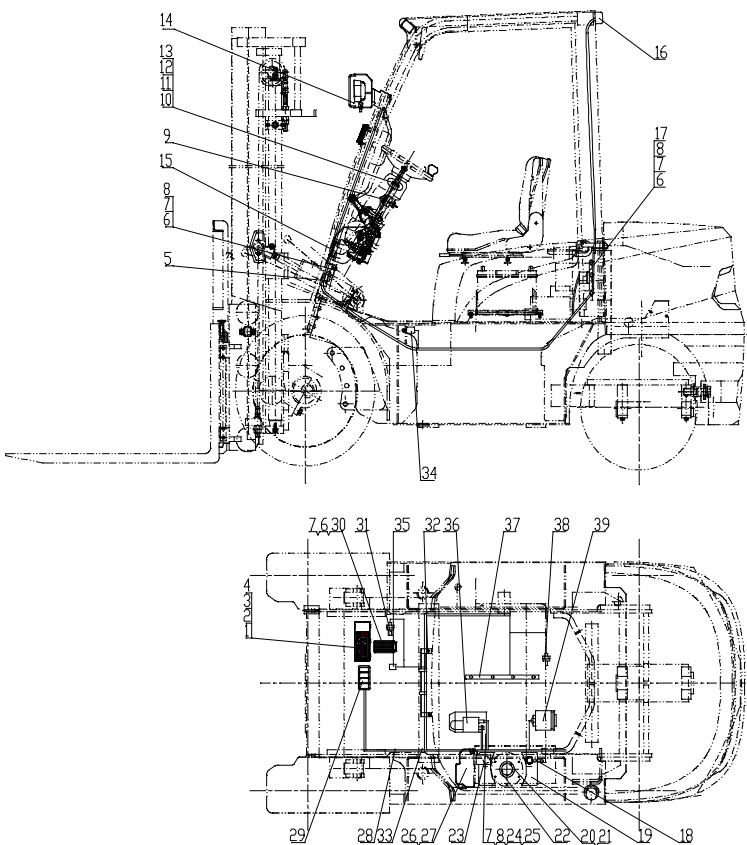

序号 Item	物料码 Part No.	名称 Description	数量 Qty.	备注或适用车型 Remarks Or Serial No.	原物料码 Original Part No.
16	207600040099	后灯总成	1	见图 II, See Fig.II	XR310-770000-000
17	207900120038	倒车蜂鸣器	1		NC9717-700500-000
18	207700040004	蓄电池负极引线	1		N163-700200-000
19	207500030002	少维护蓄电池 Battery,	1	12V90Ah	R960-700002-000
20	300040170019	螺钉M5×12	5		G000067-005012-00
21	300030140015	垫圈5	5		J000982-000005-00
22	207300010024	油量传感器	1		NC967-700400-000
23	207700060020	蓄电池正极引线	1		N150-700100-000
24	207700100002	起动机接地线	1		R960-700300-000
25	300010040165	螺栓M8×12	1		G005783-008012-00
26	207400010213	控制盒总成	1	见图 VIII, See Fig.VIII	XR310-706000-000
27	310070030007	螺钉组件	2		N163-420100-000
28	207100012650	车身主线束	1		XR310-710000-000
29	207200060043	四卡翘板开关 Four	1	见图 VI, See Fig.VI	QY200-700001-000

图2 电气系统 Fig.2 Electrical system	CPQD15/18-XRW21	CPQYD15-XRW21
------------------------------------	-----------------	---------------



图2 电气系统
Fig.2 Electrical system

CPQD15/18-XRW21
CPYD15/18-XRW51F

CPQYD15-XRW21

CPQD15/18-XRW21F

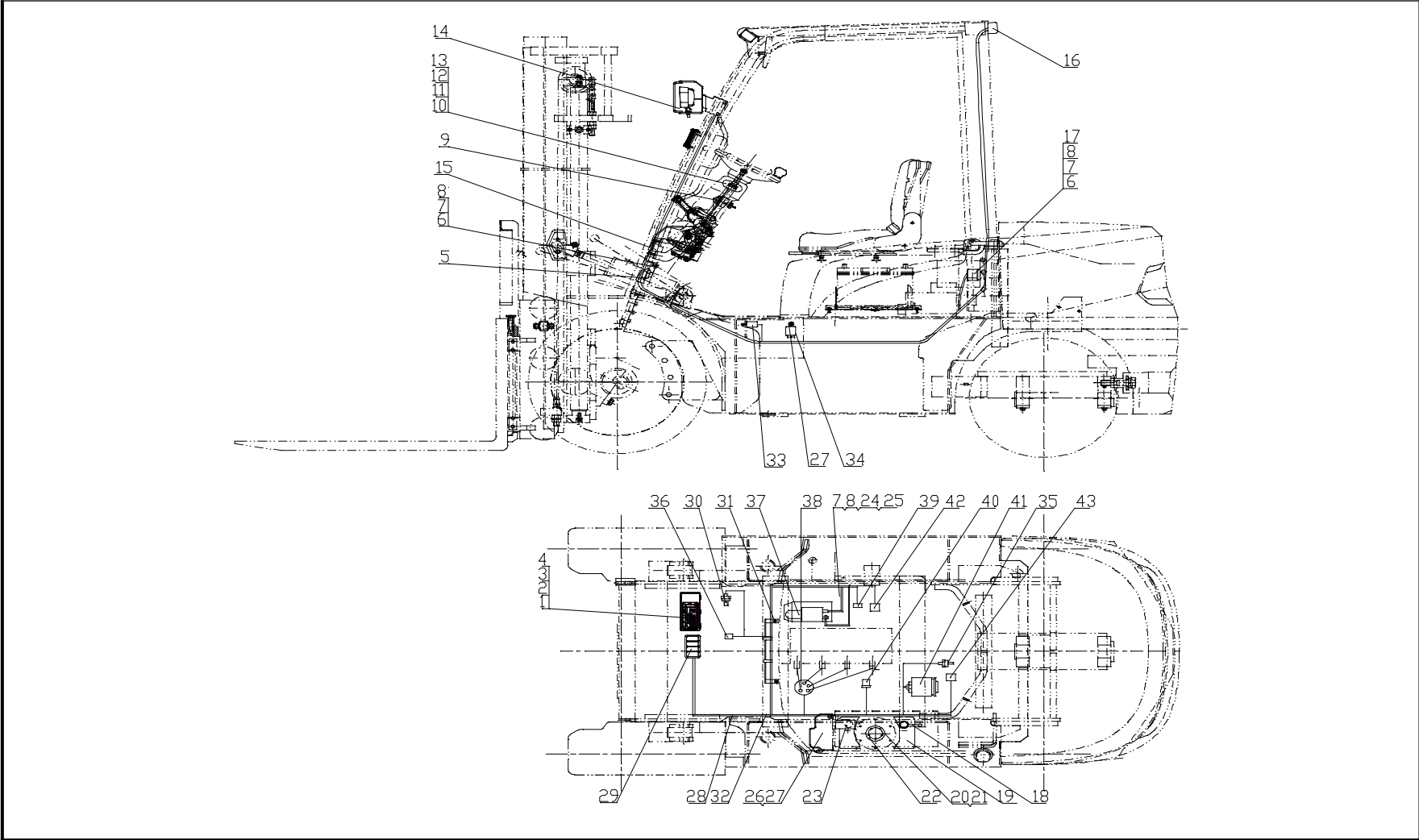
CPQYD15-XRW21F

序号 Item No.	物料码 Part No.	名称 Description	数量 Qty.	备注或适用车型 Remarks Or Serial No.	原物料码 Original Part No.
1	207900050174	仪表总成	1	见图 V ,See Fig.V	XR310-740000-000
2	300040070036	螺钉M4×12	4		G000818-004012-00
3	300030040011	垫圈4	4		G0097P1-000004-00
4	300030010012	垫圈4	4		G000093-000004-00
5	207900130006	喇叭	1	见图 III ,See Fig.III	N163-700009-000
6	300010120005	螺栓M8×16	2		G0029P2-008016-00
7	300030010015	垫圈8	4		G000093-000008-00
8	300030040014	垫圈8	4		G0097P1-000008-00
9	207200030016	预热起动开关	1		R450-740200-000
10	207200020024	组合开关总Combination	1	见图 IV ,See Fig.IV	XF250-705000-000
11	300030010013	垫圈5	4		G000093-000005-00
12	300030040012	垫圈5	4		G0097P1-000005-00
13	300040070007	螺钉M5×10	4		G000818-005010-00
14	207600020169	前灯总成	1	见图 I ,See Fig.I	XR310-760000-000
15	207900080028	扎带	5		XF250-700001-G00

图2 电气系统
Fig.2 Electrical system

CPQD15/18-XRW21
CPYD15/18-XRW51F

CPQYD15-XRW21

CPQD15/18-XRW21F

CPQYD15-XRW21F

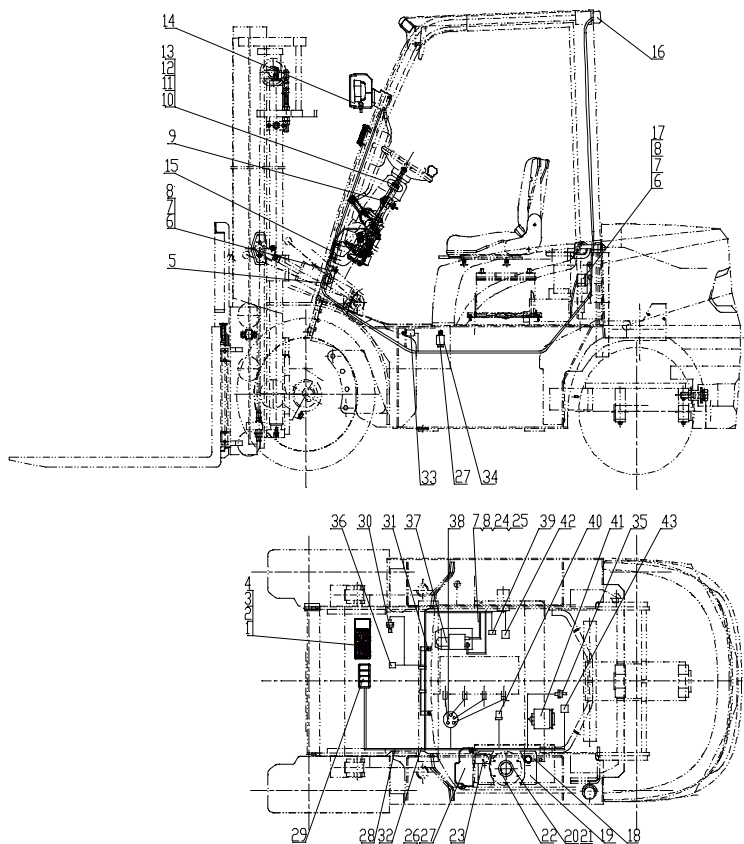

序号 Item No.	物料码 Part No.	名称 Description	数量 Qty.	备注或适用车型 Remarks Or Serial No.	原物料码 Original Part No.
16	207600040099	后灯总成	1	见图 II, See Fig. II	XR310-770000-000
17	207900120038	倒车蜂鸣器	1		NC9717-700500-000
18	207700040004	蓄电池负极引线	1		N163-700200-000
19	207500030001	少维护蓄电池 Battery,	1	12V60Ah	R840-700001-000
20	300040170019	螺钉M5×12	5		G000067-005012-00
21	300030140015	垫圈5	5		J000982-000005-00
22	207300010024	油量传感器	1		NC967-700400-000
23	207700060019	蓄电池正极引线	1		N152-700100-000
24	207700100002	起动机接地线	1		R960-700300-000
25	300010040165	螺栓M8×12	1		G005783-008012-00
26	207400010213	控制盒总成	1	见图 VIII, See Fig. VIII	XR310-706000-000
27	310070030007	螺钉组件	4		N163-420100-000
28	207100012688	车身主线束	1		XR312-710000-000
28	207100012677	车身主线束	1		XR313-710000-000

	29	207200060043	四卡翘板开关 Four	1	见图 VI, See Fig. VI	QY200-700001-000
--	----	--------------	-------------	---	--------------------	------------------

图2 电气系统 Fig.2 Electrical system	CPQD15/18-XRW21	CPQYD15-XRW21	CPQD15/18-XRW21F	CPQYD15-XRW21F		
	CPYD15/18-XRW51F					
	序号 Item	物料码 Part No	名称 Description	数量 Qty	备注或适用车型 Remarks Or Serial No	原物料码 Original Part No
	29	207200060232	四卡翘板开关 Four	1	见图 VI, See Fig. VI	XR313-700100-000
	30	207200090032	油温报警器 Fuel	1		NC9717-700300-000
	31	207100010464	主线束固定支架	1		R962-701000-000
	32	207900080013	捆线带	14		PKD-300-G00
	33	207200080035	制动灯开关	1		NC9717-700600-000
	34	207400030025	汽化器继电器 Carburetor	1		XF251-700200-000
	35	207300050002	水温传感器	1		N163-700006-000
	36		换向电磁阀 Electrom	1	变速箱配 Supply by transmi	
	37		起动机	1	发动机配套	
	38		分电器	1	发动机配	
	39		汽化器	1	发动机配	
	40		油压报警器	1	发动机配	
	41		发电机	1	发动机配套	

	42		油阀	1	LPG-QY发动机配	
	43		气阀	1	LPG-QY发动机配	

图3 电气系统 Fig.3 Electrical system	CPC10/15/18-XRG71J CPC10/15/18-XRG71
------------------------------------	---



图3 电气系统
Fig.3 Electrical system

CPC10/15/18-XRG71J CPC10/15/18-XRG71

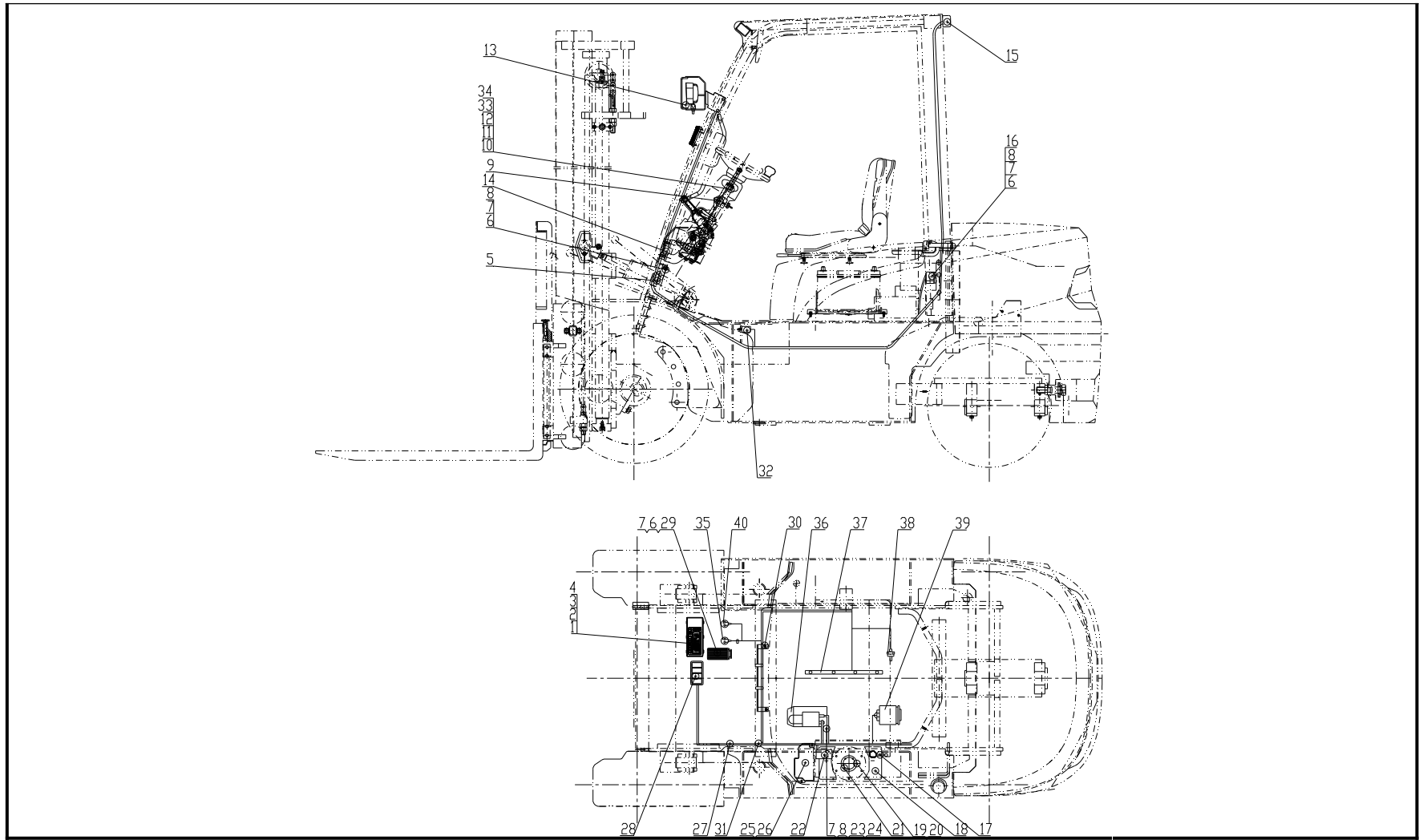
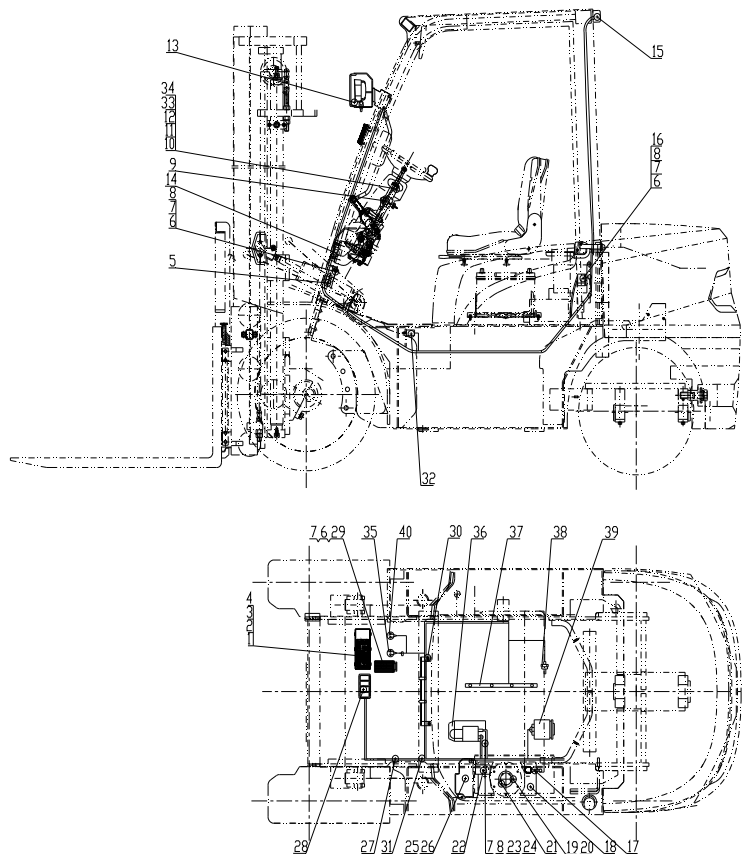

序号 Item	物料码 Part No.	名称 Description	数量 Qty.	备注或适用车型 Remarks Or Serial No.	原物料码 Original Part No.
1	207900050174	仪表总成	1	见图 V ,See Fig.V	XR310-740000-000
2	300040070036	螺钉M4×12	4		G000818-004012-00
3	300030040011	垫圈4	4		G0097P1-000004-00
4	300030010012	垫圈4	4		G000093-000004-00
5	207900130006	喇叭	1	见图 III ,See Fig. III	N163-700009-000
6	300010120005	螺栓M8×16	5		G0029P2-008016-00
7	300030010015	垫圈8	7		G000093-000008-00
8	300030040014	垫圈8	4		G0097P1-000008-00
9	207200030016	预热起动开关	1		R450-740200-000
10	300030010013	垫圈5	4		G000093-000005-00
11	300030040012	垫圈5	4		G0097P1-000005-00
12	300040070007	螺钉M5×10	4		G000818-005010-00
13	207600020169	前灯总成	1	见图 I ,See Fig.I	XR310-760000-000
14	207900080028	扎带	5		XF250-700001-G00
15	207600040099	后灯总成	1	见图 II ,See Fig.II	XR310-770000-000

图3 电气系统
Fig.3 Electrical system

CPC10/15/18-XRG71J CPC10/15/18-XRG71

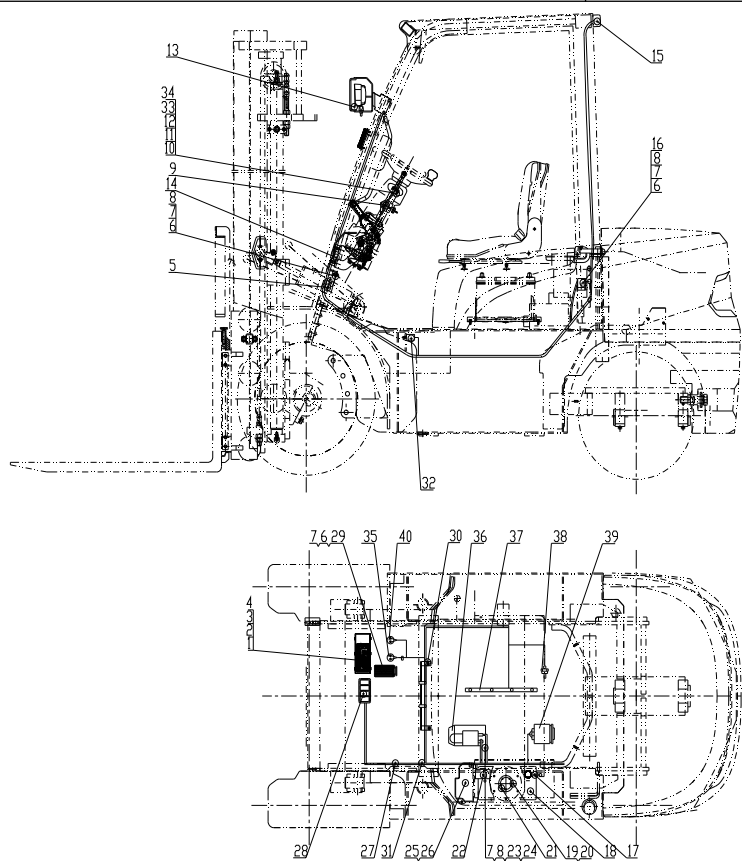

序号 Item	物料码 Part No.	名称 Description	数量 Qty.	备注或适用车型 Remarks Or Serial No.	原物料码 Original Part No.
16	207900120038	倒车蜂鸣器	1		NC9717-700500-000
17	207700040004	蓄电池负极引线	1		N163-700200-000
18	207500030002	少维护蓄电池 Battery,	1	12V90Ah	R960-700002-000
19	300040170019	螺钉M5×12	5		G000067-005012-00
20	300030140015	垫圈5	5		J000982-000005-00
21	207300010024	油量传感器	1		NC967-700400-000
22	207700060020	蓄电池正极引线	1		N150-700100-000
23	207700100002	起动机接地线	1		R960-700300-000
24	300010040165	螺栓M8×12	1		G005783-008012-00
25	207400010239	控制盒总成	1	见图XI,See FigXI.	XR300-706000-000
26	310070030007	螺钉组件	2		N163-420100-000
27	207100012813	车身主线束	1		XR300-710000-000
28	207200060043	四卡翘板开关 Four	1	见图VI,See Fig.VI	QY200-700001-000
29	207900310005	油门踏板	1		XB455-700002-000

<p>图4 电气系统 Fig.4 Electrical system</p>	<p>CPCD15/18-XRW10 CPCD15/18-XRW10 B CPCD15/18-XRW10 F CPC15/18-XRW10</p>
--	--



图4 电气系统
Fig.4 Electrical system

CPCD15/18-XRW10

CPCD15/18-XRW10 B

CPCD15/18-XRW10 F

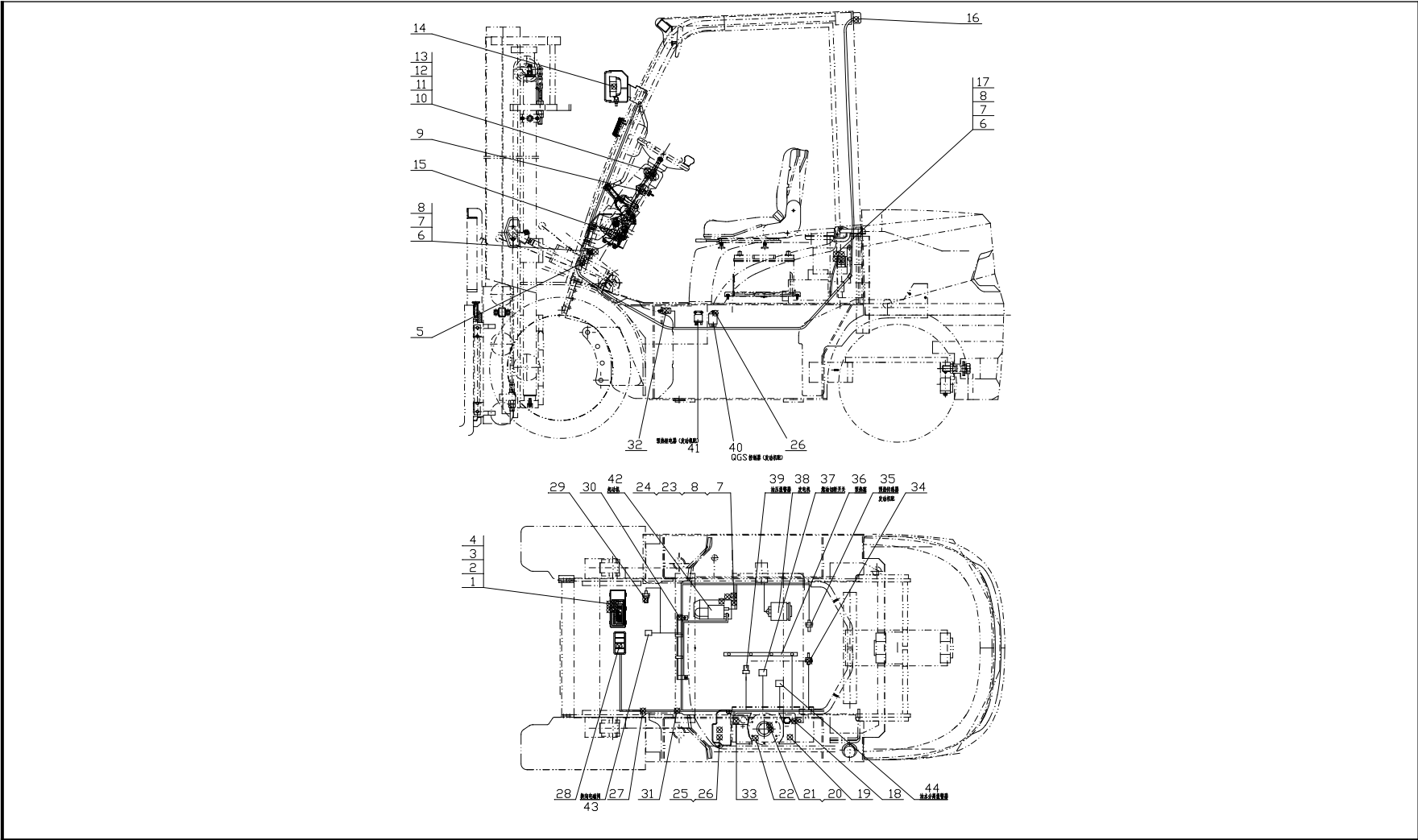
CPC15/18-XRW10

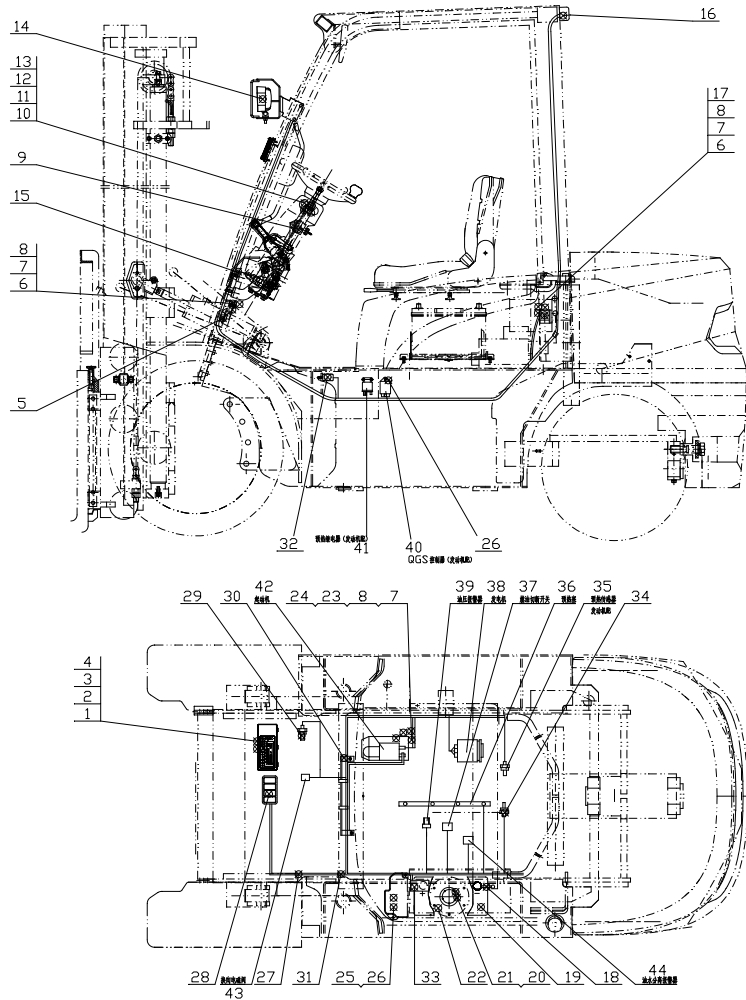

序号 Item No.	物料码 Part No.	名称 Description	数量 Qty.	备注或适用车型 Remarks Or Serial No.	原物料码 Original Part No.
1	207900050174	仪表总成	1	见图 V ,See Fig.V	XR310-740000-000
2	300040070036	螺钉M4×12	4		G000818-004012-00
3	300030040011	垫圈4	4		G0097P1-000004-00
4	300030010012	垫圈4	4		G000093-000004-00
5	207900130006	喇叭	1	见图 III ,See Fig. III	N163-700009-000
6	300010120005	螺栓M8×16	2		G0029P2-008016-00
7	300030010015	垫圈8	4		G000093-000008-00
8	300030040014	垫圈8	4		G0097P1-000008-00
9	207200030016	预热起动开关	1		R450-740200-000
10	207200020024	Combination Switch assy	1		XF250-705000-000
10	207200010056	转向灯开关	1		XR300-705000-000
11	300030010013	垫圈5	4		G000093-000005-00
12	300030040012	垫圈5	4		G0097P1-000005-00
13	300040070007	螺钉M5×10	4		G000818-005010-00
14	207600020169	前灯总成	1		XR310-760000-000

图4 电气系统
Fig.4 Electrical system

CPCD15/18-XRW10 CPCD15/18-XRW10 B CPCD15/18-XRW10 F CPC15/18-XRW10

序号 Item No.	物料码 Part No.	名称 Description	数量 Qty.	备注或适用车型 Remarks Or Serial No.	原物料码 Original Part No.
15	207900080028	扎带	5		XF250-700001-G00
16	207600040099	后灯总成	1	见图 II ,See Fig.II	XR310-770000-000
17	207900120038	倒车蜂鸣器	1		NC9717-700500-000
18	207700040004	蓄电池负极引线	1		N163-700200-000
19	207500030002	少维护蓄电池 Battery,	1	12V90Ah	R960-700002-000
20	300040170019	螺钉M5×12	5		G000067-005012-00
21	300030140015	垫圈5	5		J000982-000005-00
22	207300010024	油量传感器	1		NC967-700400-000
23	300010040165	螺栓M8×12	1		G005783-008012-00
24	207700100002	起动机接地线	1		R960-700300-000
25	207400010213	控制盒总成	1	见图VIII See Fig.VIII	XR310-706000-000
25	207400010239	控制盒总成	1	见图VI See Fig.VI	XR300-706000-000
26	310070030007	螺钉组件	9		N163-420100-000
27	207100012942	车身主线束	1		XR317-710000-000

		27	207100012991	车身主线束	1		XR307-710000-000
--	--	----	--------------	-------	---	--	------------------

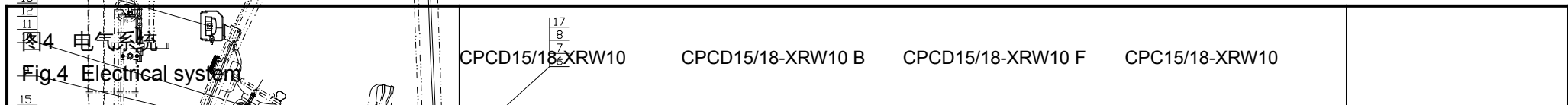

序号 Item No.	物料码 Part No.	名称 Description	数量 Qty.	备注或适用车型 Remarks Or Serial No.	原物料码 Original Part No.
27	207100013045	车身主线束	1		XR307-710000-000
28	207200060043	四卡翘板开关 Four	1	见图 VI, See Fig. VI	QY200-700001-000
29	207200090032	油温报警器	1		NC9717-700300-000
30	207100010464	主线束固定支架Support,	14		R962-701000-000
30	207100010460	主线束固定支架Support,	14		N150-701000-000
31	207900080013	捆线带	1		PKD-300-G00
31	207900080013	捆线带	14		PKD-300-G00
32	207200080035	制动灯开关	1		NC9717-700600-000
33	207700060019	蓄电池正极引线	1		N152-700100-000
34	207300050012	水温传感器	1		NC9321-700006-001
35		预热传感器	1	发动机配	
36		预热塞	1	发动机配	
37		燃油切断开关Fuel	1	发动机配	

	38		发电机	1	发动机配	
	39		油压报警器	1	发动机配	

图4 电气系统 Fig.4 Electrical system	CPCD15/18-XRW10 CPCD15/18-XRW10 B CPCD15/18-XRW10 F CPC15/18-XRW10					
	序号 Item	物料码 Part No.	名称 Description	数量 Qty.	备注或适用车型 Remarks Or Serial No.	原物料码 Original Part No.
	40		QGS控制器	1	发动机配	
	41		预热继电器	1	发动机配	
	42		起动机	1	发动机配	
	43		Electromagnetic reversing	1	变速箱配Supply by transmi	
	44		油水分离报警Water-oil	1	发动机配	



图5 电气系统
Fig.5 Electrical system

CPCD15/18-XRW32B CPCD15/18-XRW32F



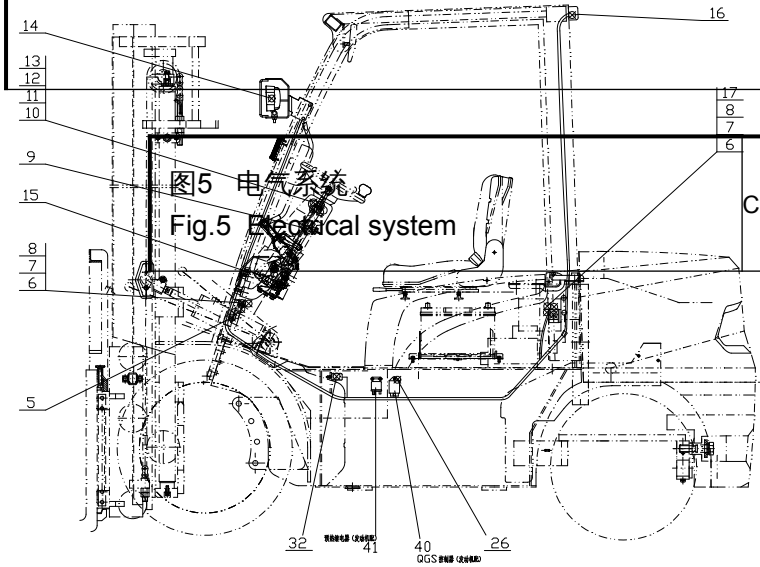
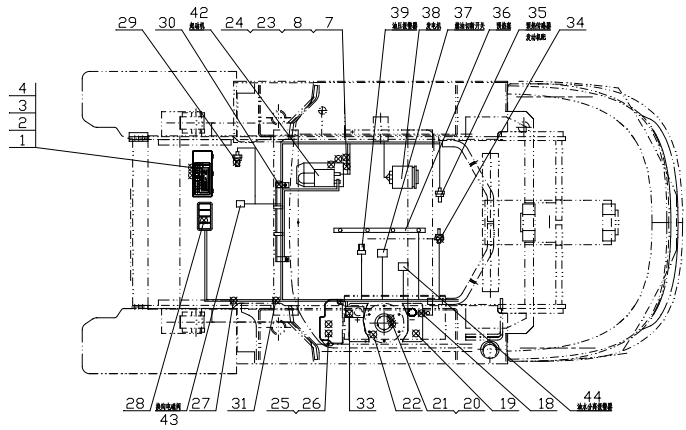

图5 电气系统
Fig.5 Electrical system

CPCD15/18-XRW32B CPCD15/18-XRW32F

序号 Item No.	物料码 Part No.	名称 Description	数量 Qty.	备注或适用车型 Remarks Or Serial No.	原物料码 Original Part No.
1	207900050174	仪表总成	1	见图 V ,See Fig.V	XR310-740000-000
2	300040070036	螺钉M4×12	4		G000818-004012-00
3	300030040011	垫圈4	4		G0097P1-000004-00
4	300030010012	垫圈4	4		G000093-000004-00
5	207900130006	喇叭	1	见图 III ,See Fig.III	N163-700009-000
6	300010120005	螺栓M8×16	2		G0029P2-008016-00
6	300010120005	螺栓M8×16	3		G0029P2-008016-00
7	300030010015	垫圈8	7		G000093-000008-00
7	300030010015	垫圈8	5		G000093-000008-00
8	300030040014	垫圈8	7		G0097P1-000008-00
8	300030040014	垫圈8	5		G0097P1-000008-00
9	207200030016	预热起动开关	1		R450-740200-000
10	207200020024	组合开关总Combination	1	见图 IV ,See Fig.IV	XF250-705000-000
11	300030010013	垫圈5	4		G000093-000005-00
12	300030040012	垫圈5	4		G0097P1-000005-00

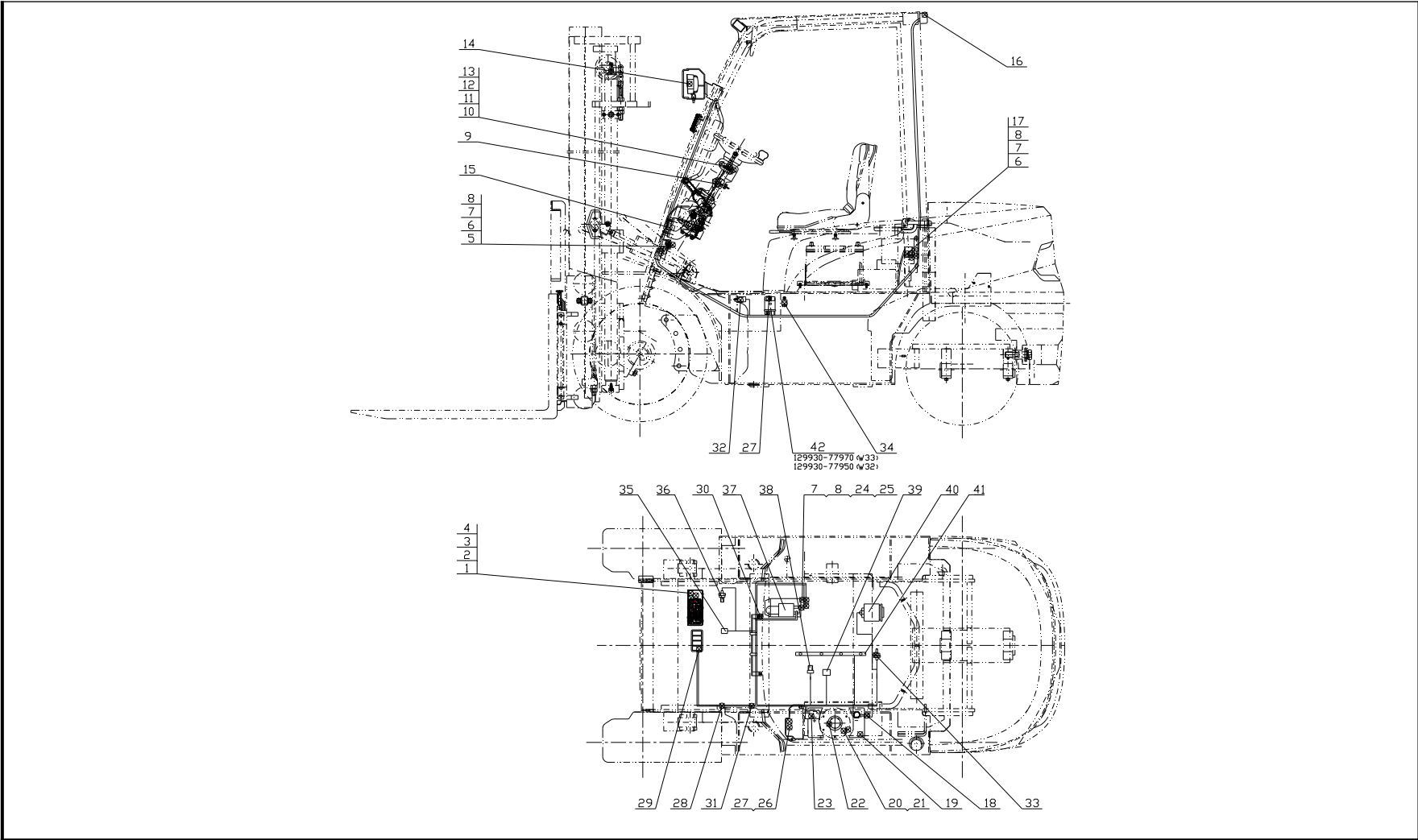

图5 电气系统
Fig.5 Electrical system

CPCD15/18-XRW32B CPCD15/18-XRW32F



序号 Item No.	物料码 Part No.	名称 Description	数量 Qty.	备注或适用车型 Remarks Or Serial No.	原物料码 Original Part No.
13	300040070007	螺钉M5×10	4		G000818-005010-00
14	207600020169	前灯总成	1	见图 I ,See Fig.I	XR310-760000-000
15	207900080028	扎带	13		XF250-700001-G00
15	207900080028	扎带	5		XF250-700001-G00
16	207600040099	后灯总成	1	见图 II ,See Fig.II	XR310-770000-000
17	207900120038	倒车蜂鸣器	1		NC9717-700500-000
18	207700040004	蓄电池负极引线	1		N163-700200-000
19	207500030002	少维护蓄电池 Battery,	1	12V90Ah	R960-700002-000
20	300040170019	螺钉M5×12	5		G000067-005012-00
21	300030140015	垫圈5	5		J000982-000005-00
22	207300010024	油量传感器	1		NC967-700400-000
23	207700060020	蓄电池正极引线	1		N150-700100-000
24	207700100002	起动机接地线	1		R960-700300-000
25	300010040165	螺栓M8×12	1		G005783-008012-00

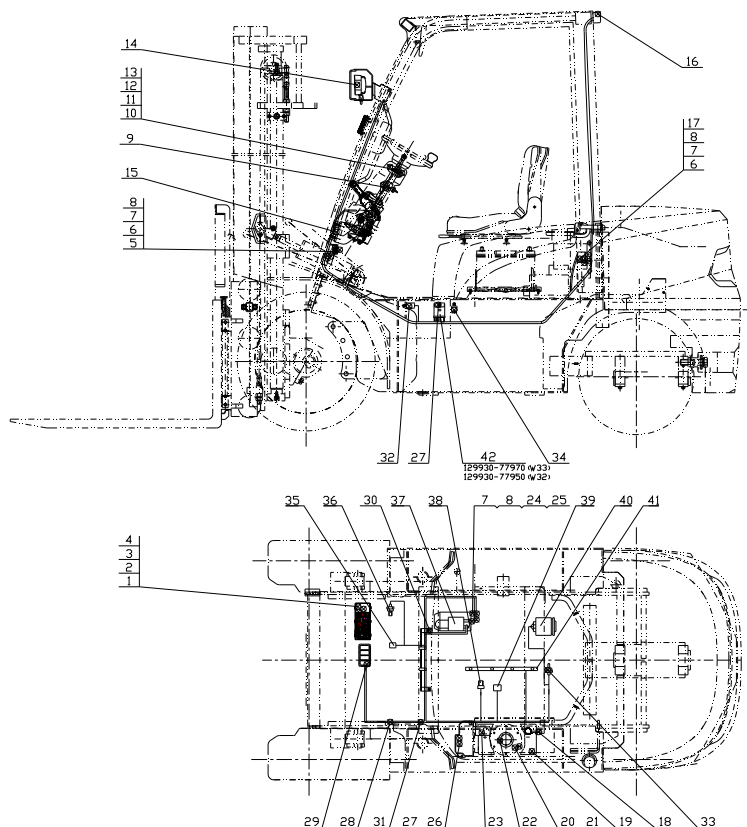
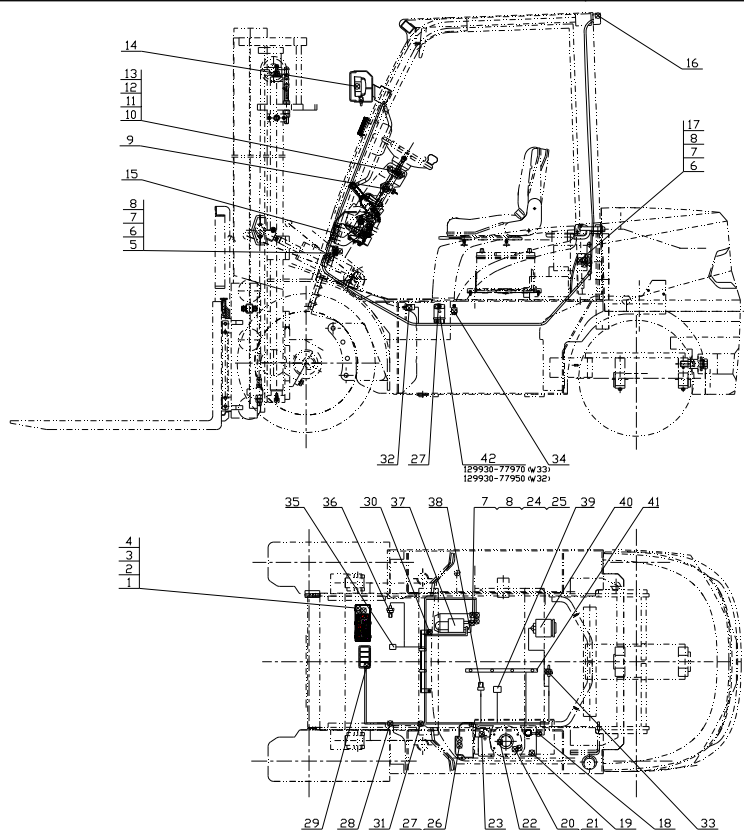

图6 电气系统
Fig.6 Electric system

CPCD15-XRW43



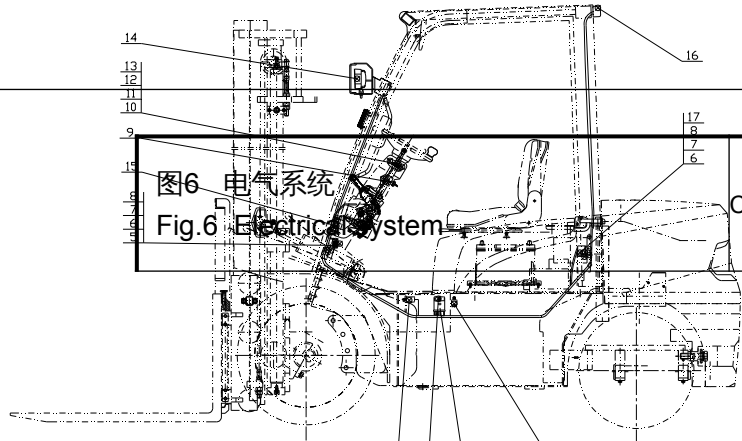
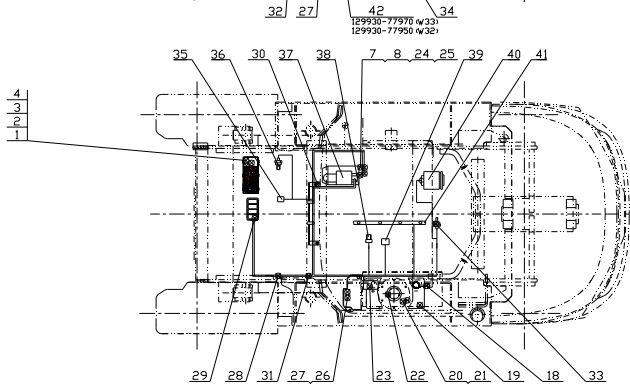

图6 电气系统
Fig.6 Electrical system

CPCD15-XRW43

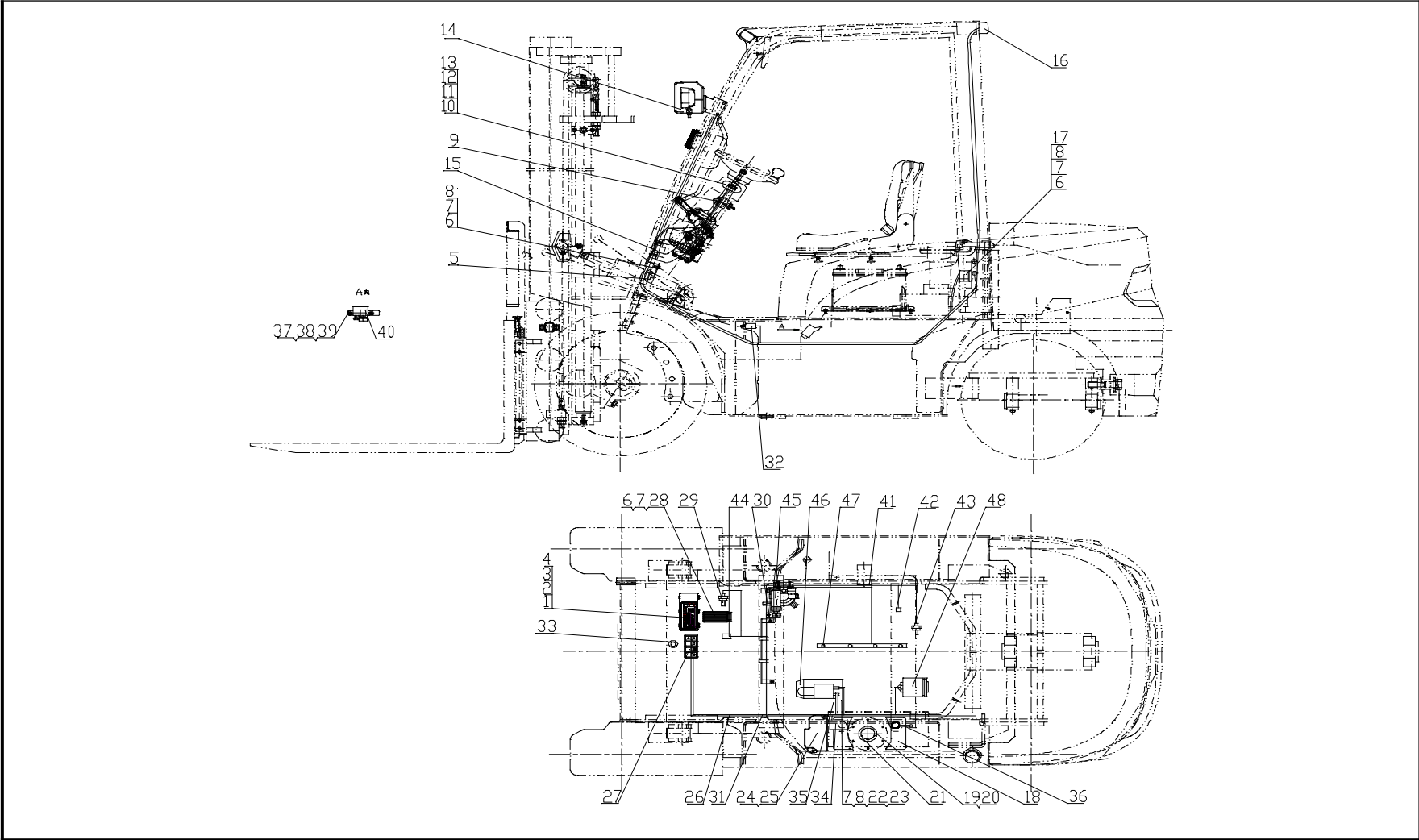
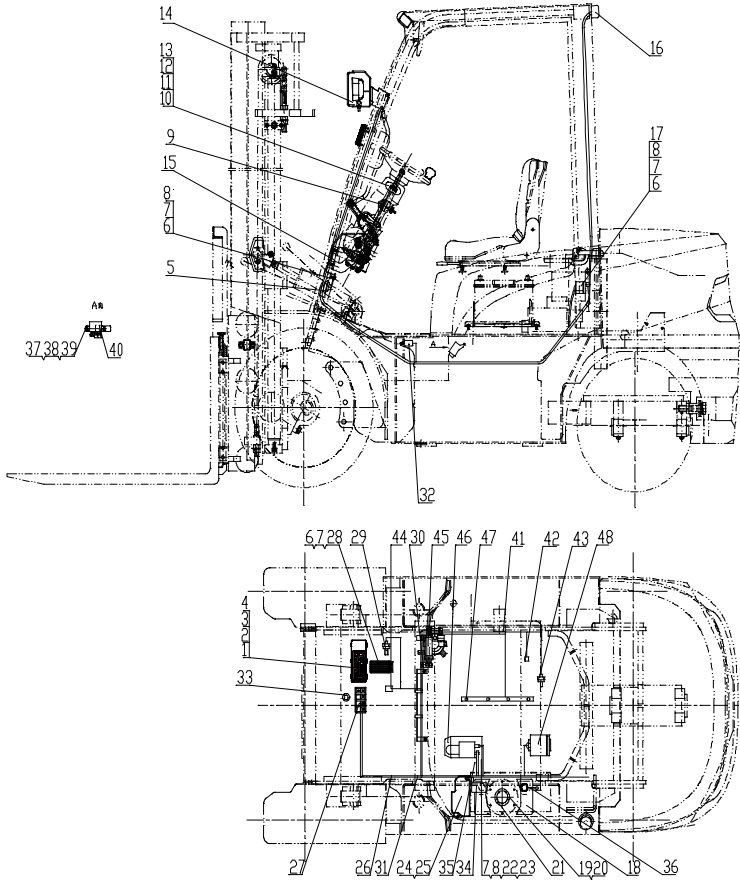

序号 Item No.	物料码 Part No.	名称 Description	数量 Qty.	备注或适用车型 Remarks Or Serial No.	原物料码 Original Part No.
1	207900050174	仪表总成	1	见图 V ,See Fig.V	XR310-740000-000
2	300040070036	螺钉M4×12	4		G000818-004012-00
3	300030040011	垫圈4	4		G0097P1-000004-00
4	300030010012	垫圈4	4		G000093-000004-00
5	207900130006	喇叭	1	见图 III ,See Fig.III	N163-700009-000
6	300010120005	螺栓M8×16	5		G0029P2-008016-00
7	300030010015	垫圈8	7		G000093-000008-00
8	300030040014	垫圈8	4		G0097P1-000008-00
9	207200030016	预热起动开关	1		R450-740200-000
10	207200020024	组合开关总Combination	1	见图 IV ,See Fig.IV	XF250-705000-000
11	300030010013	垫圈5	4		G000093-000005-00
12	300030040012	垫圈5	4		G0097P1-000005-00
13	300040070007	螺钉M5×10	4		G000818-005010-00
14	207600020169	前灯总成	1	见图 I ,See Fig.I	XR310-760000-000
15	207900080028	扎带	5		XF250-700001-G00

图6 电气系统
Fig.6 Electrical system

CPCD15-XRW43

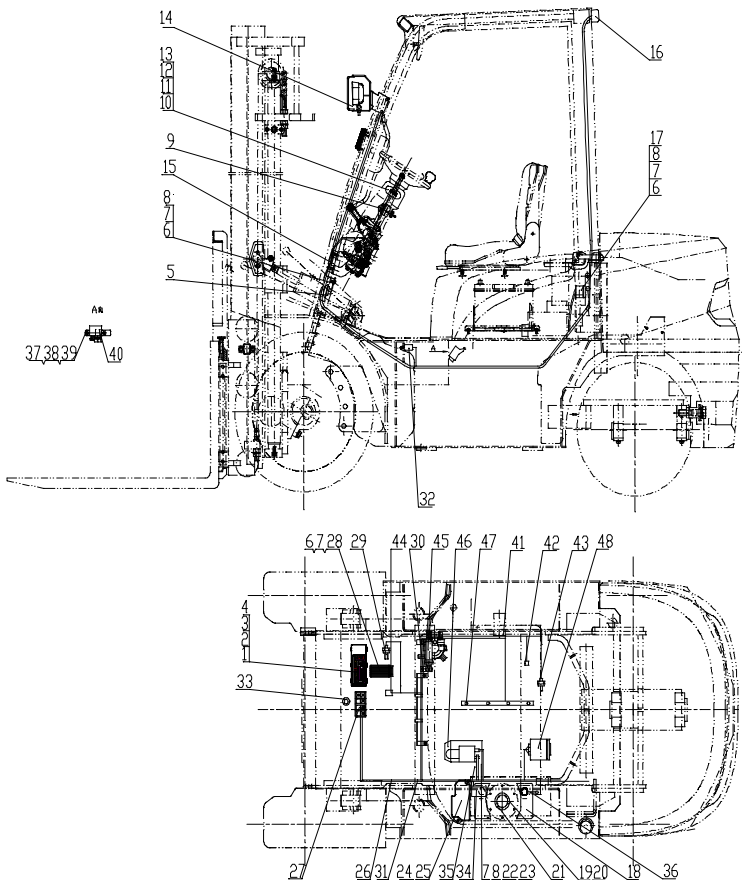

序号 Item No.	物料码 Part No.	名称 Description	数量 Qty.	备注或适用车型 Remarks Or Serial No.	原物料码 Original Part No.
16	207600040099	后灯总成	1	见图 II ,See Fig.II	XR310-770000-000
17	207900120038	倒车蜂鸣器	1		NC9717-700500-000
18	207500010022	免维护蓄电池 Battery,	1	12V90Ah	X710-700009-000
19	300040170019	螺钉M5×12	5		G000067-005012-00
20	300030140015	垫圈5	5		J000982-000005-00
21	207300010024	油量传感器	1		NC967-700400-000
22	207700100010	起动机接地线	1		XB2516-700400-000
23	300010040165	螺栓M8×12	1		G005783-008012-00
24	207400010216	控制盒总成	1	见图 IX ,See Fig.IX	XR311-706000-000
25	310070030007	螺钉组件	2		N163-420100-000
26	207100012657	车身主线束	1		XR311-710000-000
27	207200060159	四卡翘板开关 Four	1	见图 VI ,See Fig.VI	MB453-700400-000
28	207200090032	油温报警器 Fuel	1		NC9717-700300-000
29	207900310004	电子油门踏板 Electronic	1		R300-700001-000

	30	207100010464	主线束固定支架	1		R962-701000-000
--	----	--------------	---------	---	--	-----------------

图6 电气系统 Fig.6 Electrical system		CPCD15-XRW43					
序号 Item	物料码 Part No.	名称 Description	数量 Qty.	备注或适用车型 Remarks Or Serial No.	原物料码 Original Part No.		
31	207900080013	捆线带	14		PKD-300-G00		
32	207200080035	制动灯开关	1		NC9717-700600-000		
33	207200050001	紧急断电开关Emergency	1		ED250B-1-G00		
34	207700050044	蓄电池接电源开关线	1		R300-700100-000		
35	207700020020	电源开关接起动机线	1		R300-700200-000		
36	207700040048	蓄电池负极引线	1		XB2516-700300-000		
37	300030010014	垫圈6	2		G000093-000006-00		
38	300030040013	垫圈6	2		G0097P1-000006-00		
39	300040070016	螺钉M6×14	2		G000818-006014-00		
40	207400030040	预热继电器12V	1		R488-700010-000		
41	207700110007	预热线束	1		XB2516-730000-000		
42	207300020012	油压传感器	1		R457-700002-001		
43	207300050030	水温传感器	1		GR502-700001-000		

